



US00D417436S

# United States Patent [19] Tsui

[11] Patent Number: Des. 417,436

[45] Date of Patent: \*\* Dec. 7, 1999

[54] **REMOTE CONTROL UNIT BRACKET**

[76] Inventor: **Philip Y. W. Tsui**, 3513 Ingram Road, Mississauga, Ontario, Canada, L5L 4M4

[\*\*] Term: **14 Years**

[21] Appl. No.: **29/094,805**

[22] Filed: **Oct. 9, 1998**

[51] **LOC (6) Cl.** ..... **13-03**

[52] **U.S. Cl.** ..... **D13/173; D8/349**

[58] **Field of Search** ..... D13/168, 173, D13/177; D8/349, 354, 373; 211/26.1; 248/172, 176.1, 309.1, 670

[56] **References Cited**

**U.S. PATENT DOCUMENTS**

D. 390,196	2/1998	Thomas	.....	D13/173
3,293,528	12/1966	Rosen et al.	.....	248/309.1
4,458,874	7/1984	Rabas et al.	.....	248/670
5,305,980	4/1994	Le Blanc	.....	248/309.1

*Primary Examiner*—Adir Aronovich  
*Attorney, Agent, or Firm*—Blakely, Sokoloff, Taylor & Zafman

[57] **CLAIM**

The ornamental design for a remote control unit bracket, as shown and described.

**DESCRIPTION**

FIG. 1 is a top perspective view of a remote control unit

bracket;

FIG. 2 is a bottom perspective view of the remote control unit bracket shown in FIG. 1;

FIG. 3 is a front elevational view of the remote control unit bracket shown in FIG. 1;

FIG. 4 is a left side elevational view of the remote control unit bracket shown in FIG. 1;

FIG. 5 is a top plan view of the remote control unit bracket shown in FIG. 1;

FIG. 6 is a right side elevational view of the remote control unit bracket shown in FIG. 1;

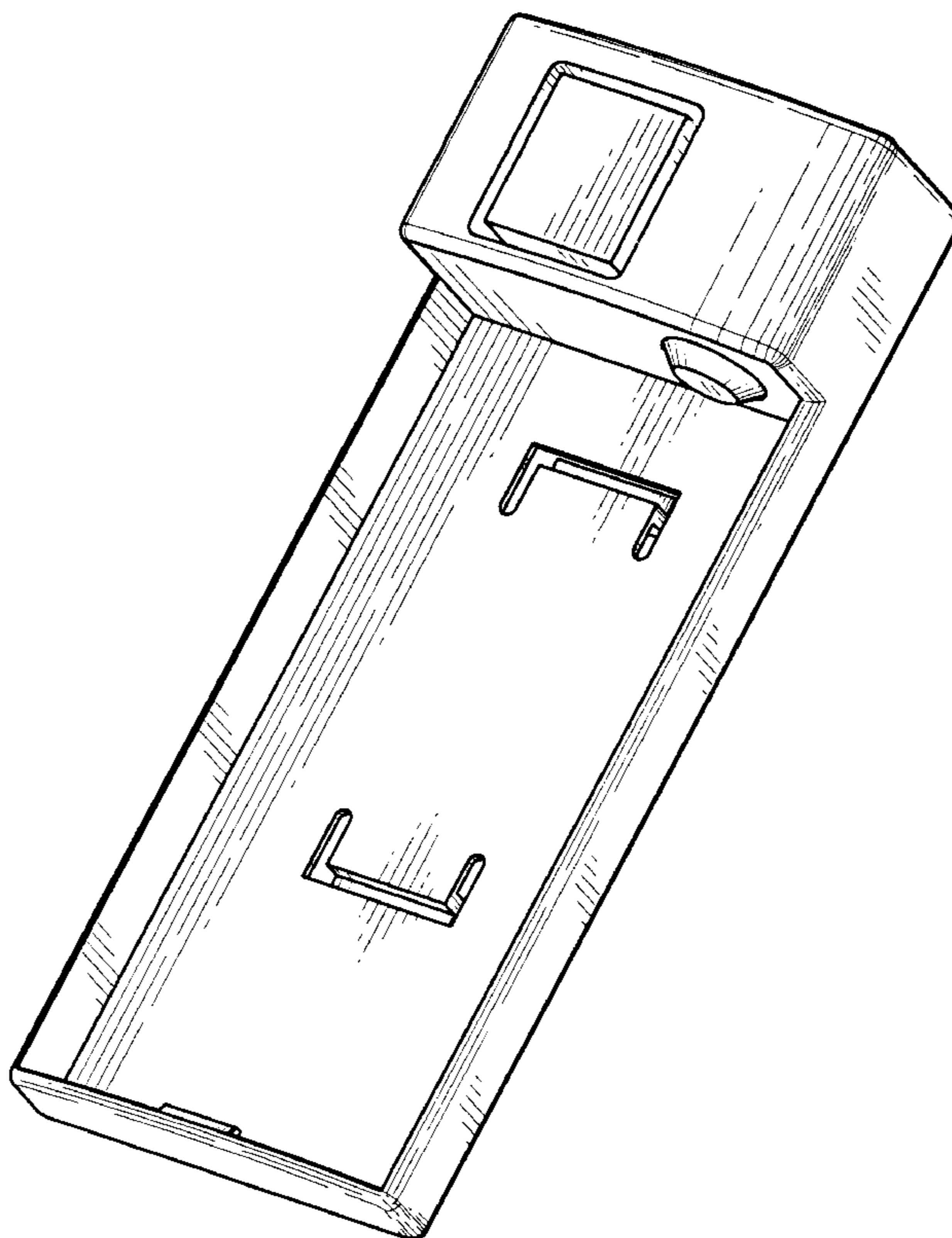
FIG. 7 is a bottom plan view of the remote control unit bracket shown in FIG. 1;

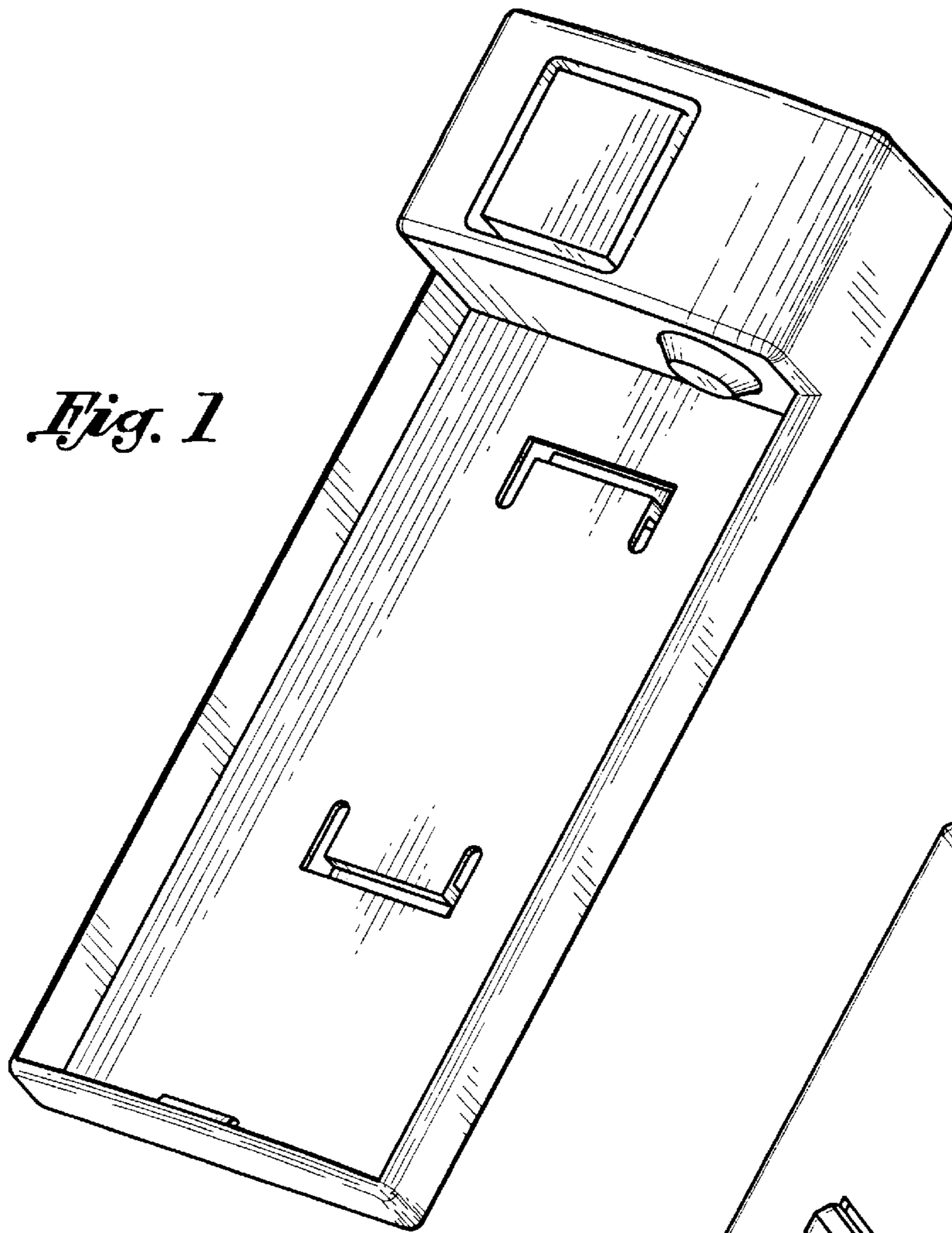
FIG. 8 is a rear elevational view of the remote control unit bracket shown in FIG. 1; and,

FIG. 9 is a top perspective view of the remote control unit bracket of FIG. 1, shown supporting a remote control unit (in phantom) in a docket position.

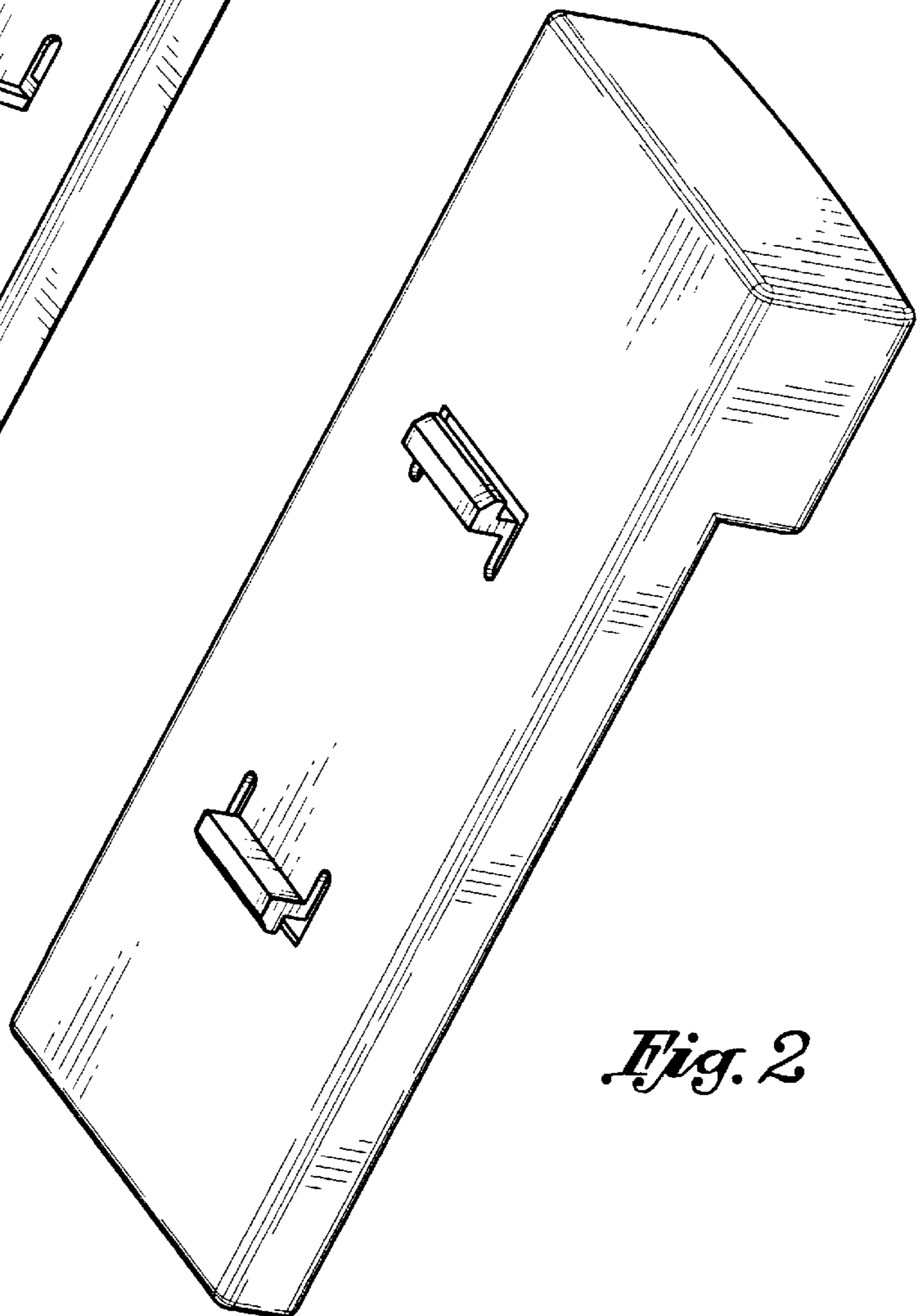
The broken line showing of a remote control unit is for illustrative purposes only and forms no part of the claimed design.

**1 Claim, 3 Drawing Sheets**

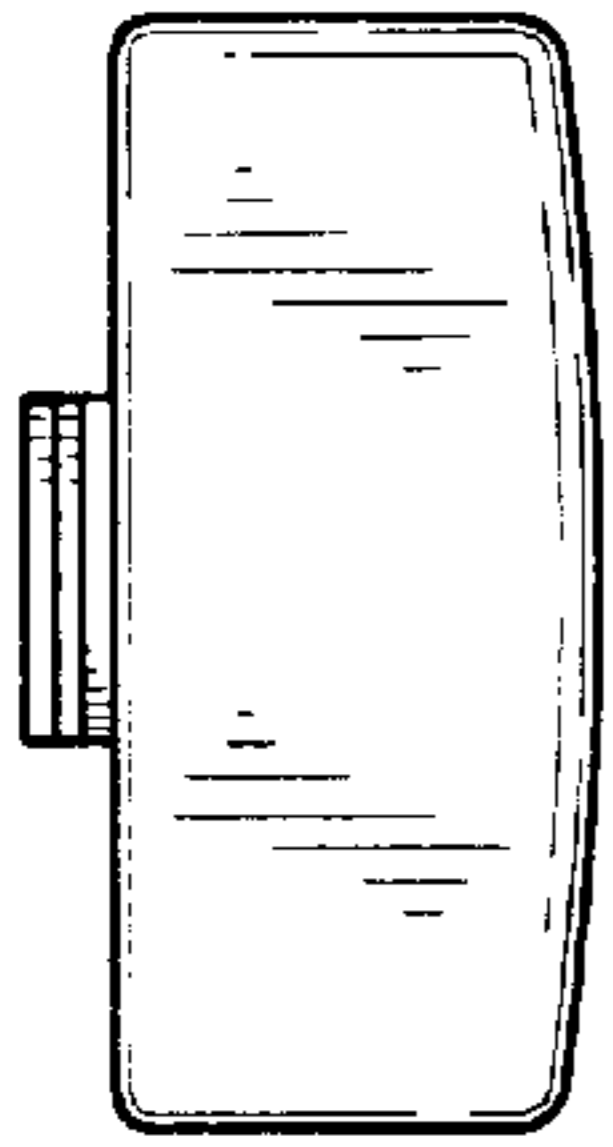




*Fig. 1*

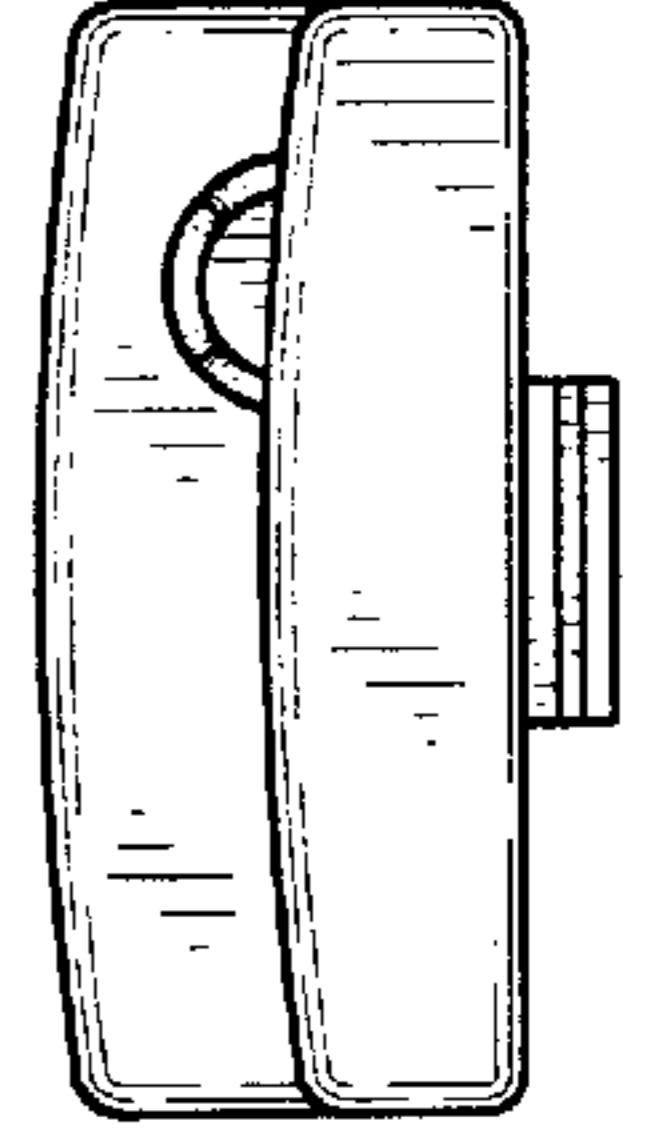
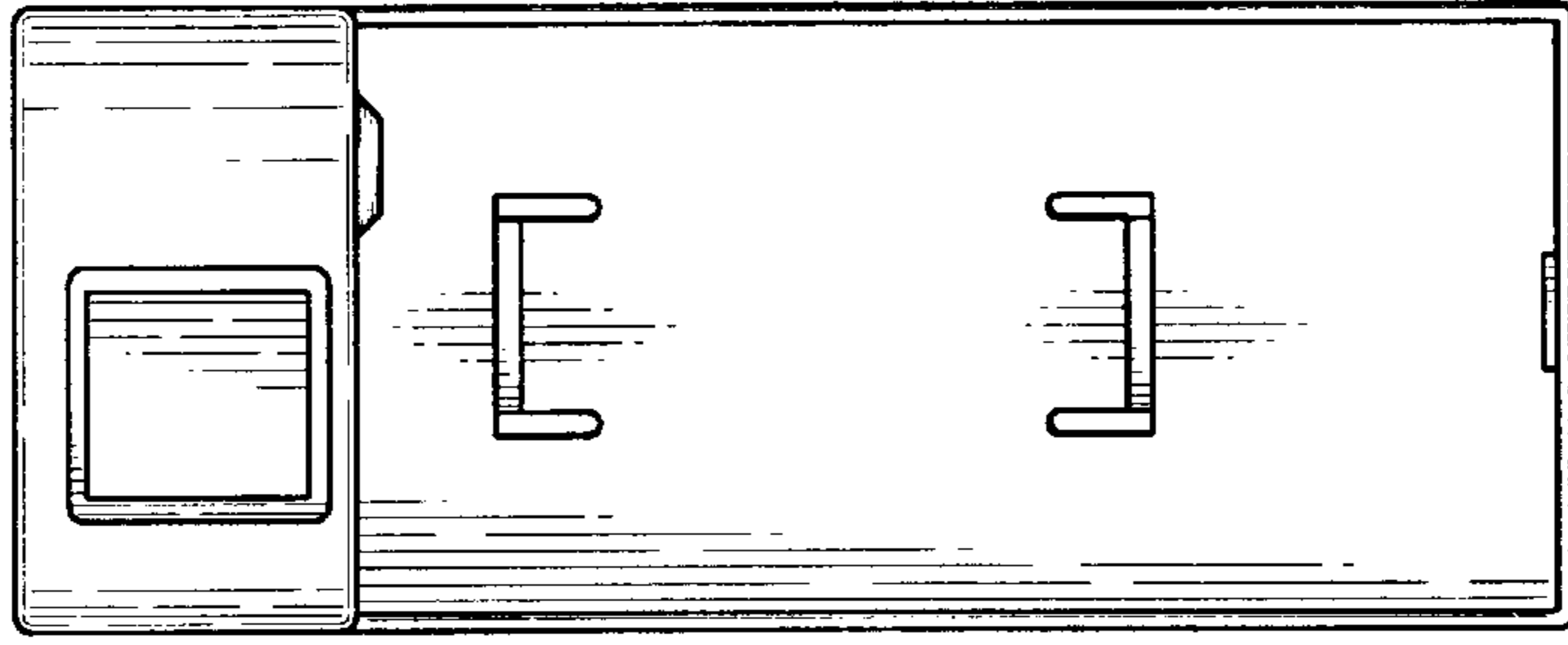


*Fig. 2*



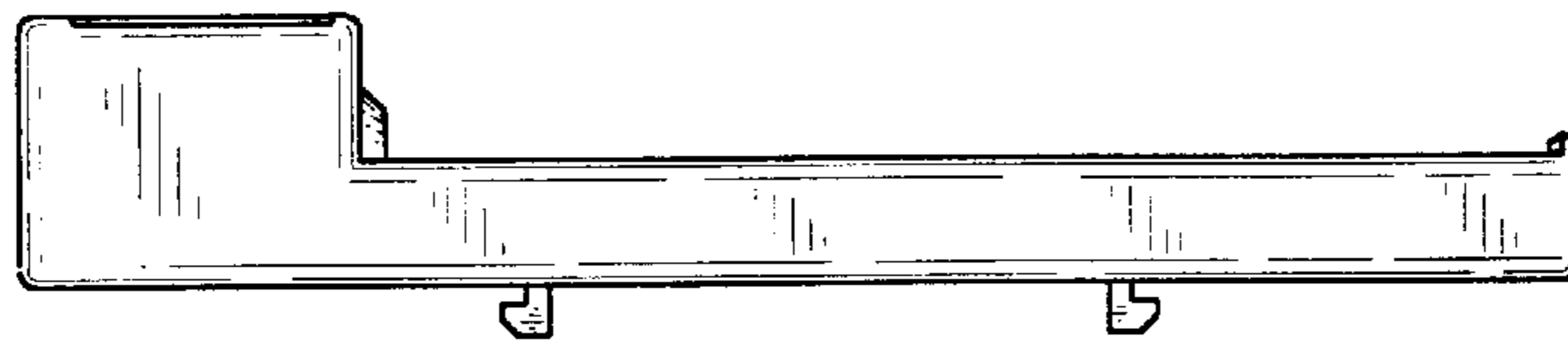
*Fig. 3*

*Fig. 5*

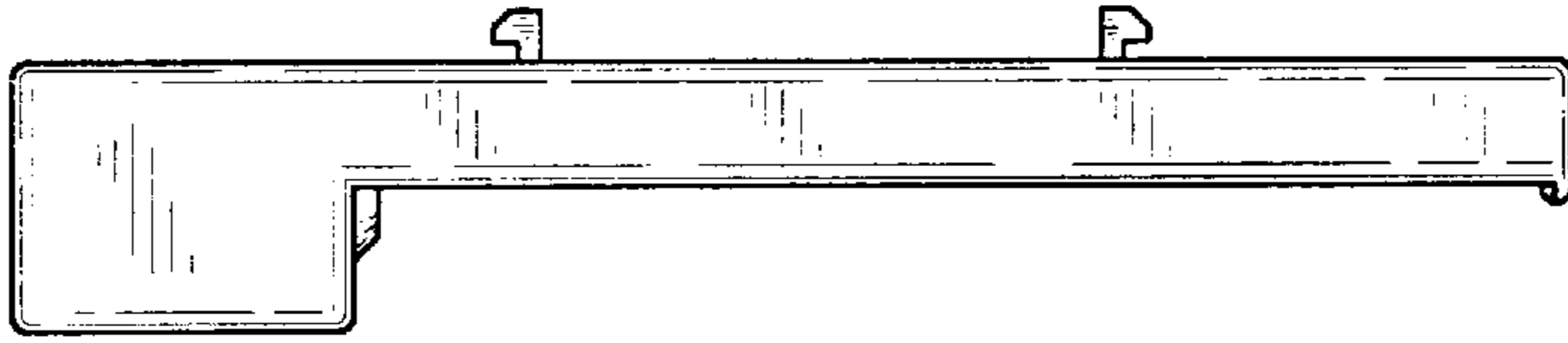


*Fig. 8*

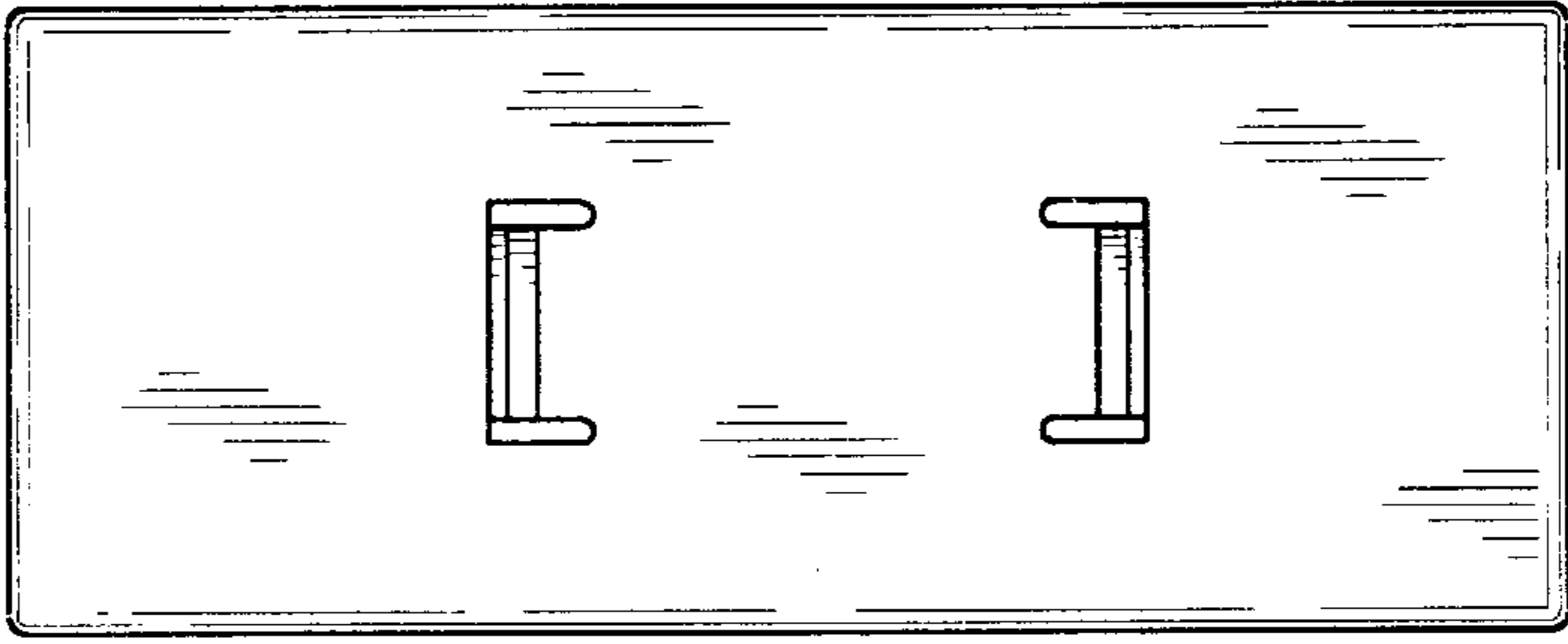
*Fig. 4*



*Fig. 6*



*Fig. 7*



*Fig. 9*

