



US00D417172S

United States Patent [19]

[11] **Patent Number: Des. 417,172**

Smith et al.

[45] **Date of Patent: ** Nov. 30, 1999**

[54] **ATV UTILITY HAULING ACCESSORY**

Attorney, Agent, or Firm—Sirote & Permutt, P.C.

[76] Inventors: **Larry Stanley Smith**, 95 Lakewood Trace, Wetumpka, Ala. 36092; **Kenneth A. Latham**, 138 Woodland Rd., Wetumpka, Ala. 36053

[57] **CLAIM**

The ornamental design for an ATV utility hauling accessory, as shown and described.

[**] Term: **14 Years**

DESCRIPTION

[21] Appl. No.: **29/090,324**

FIG. 1 is a rear perspective view of an ATV utility hauling accessory showing my new design;

[22] Filed: **Jul. 6, 1998**

FIG. 2 is a front perspective view thereof;

[51] **LOC (6) Cl. 12-10**

FIG. 3 is a side elevational view thereof;

[52] **U.S. Cl. D12/101; D12/93**

FIG. 4 is a side elevational view of the present invention shown in a transitional position;

[58] **Field of Search D12/93, 114, 101, D12/400; 296/183, 185; 280/63, 789, 401; 414/462**

FIG. 5 is a top plan view of FIG. 4;

FIG. 6 is a bottom view of FIG. 4;

[56] **References Cited**

U.S. PATENT DOCUMENTS

D. 257,966	1/1981	Page	D12/98
D. 268,830	5/1983	Sutela	D12/93
1,487,974	3/1924	Prouty .		
1,506,274	8/1924	Specht .		
1,747,422	2/1930	Butzman .		
2,249,485	7/1941	Mitchell	155/124
3,368,827	2/1968	Dashew	280/401
3,785,541	1/1974	Sibley	224/42.08
3,912,290	10/1975	Rich	280/9
3,927,779	12/1975	Johnson	214/450
4,045,040	8/1977	Fails	280/1.5
4,335,891	6/1982	Alley	280/19
4,806,063	2/1989	York	414/462
5,090,714	2/1992	Seekins	280/24

FIG. 7 is a rear elevational view of FIG. 4;

FIG. 8 is a front elevational view of FIG. 4;

FIG. 9 is a side elevational view of the present invention shown in a folded position;

FIG. 10 is a rear elevational view of FIG. 10;

FIG. 11 is a front elevational view of FIG. 10;

FIG. 12 is a top plan view of FIG. 10;

FIG. 13 is a front elevational view of FIG. 10;

FIG. 14 is a rear perspective view of the present invention shown in a folded position;

FIG. 15 is a rear perspective view of the present invention shown mounted on a typical vehicle; and,

FIG. 16 is a rear perspective view of the present invention shown in a folded position, mounted on a typical vehicle.

The vehicle, caster wheel and mounting brackets shown in broken lines are illustrative of environmental structure and are not part of the claimed design.

OTHER PUBLICATIONS

Buckmasters Whitetail Magazine Spring 1998 p. 73 The Deer Kaddy.

Primary Examiner—Melody N. Brown

1 Claim, 7 Drawing Sheets

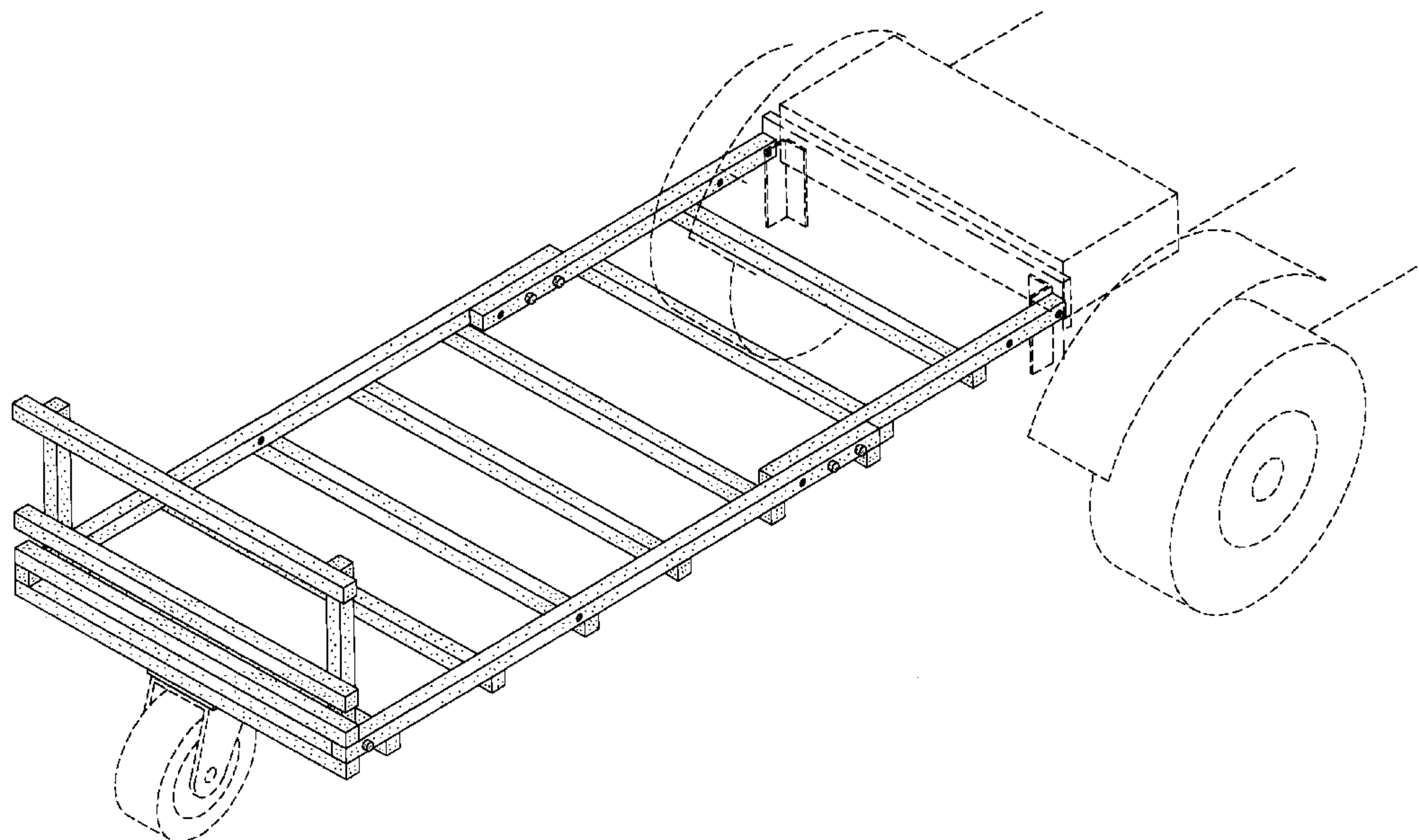

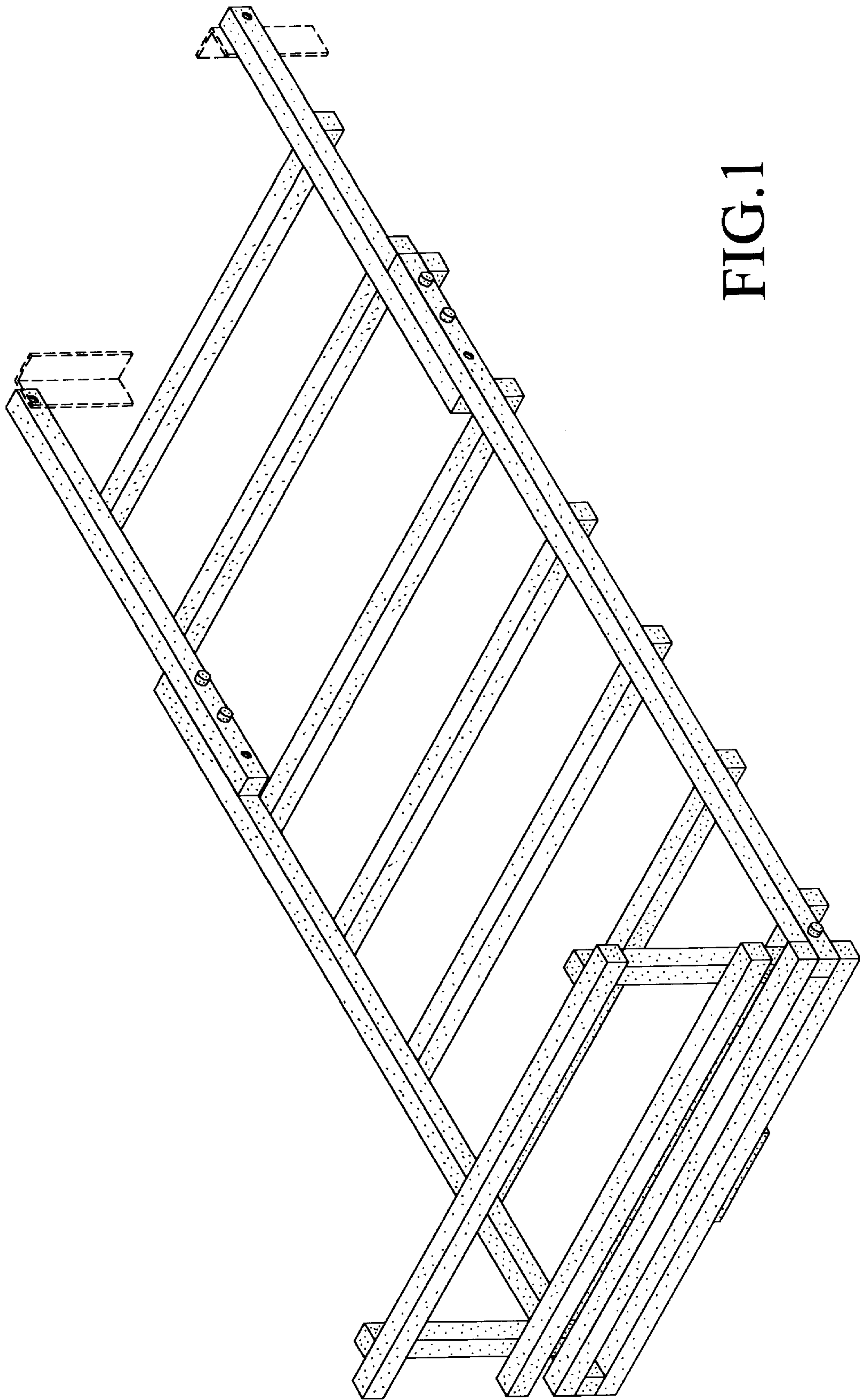

FIG. 1

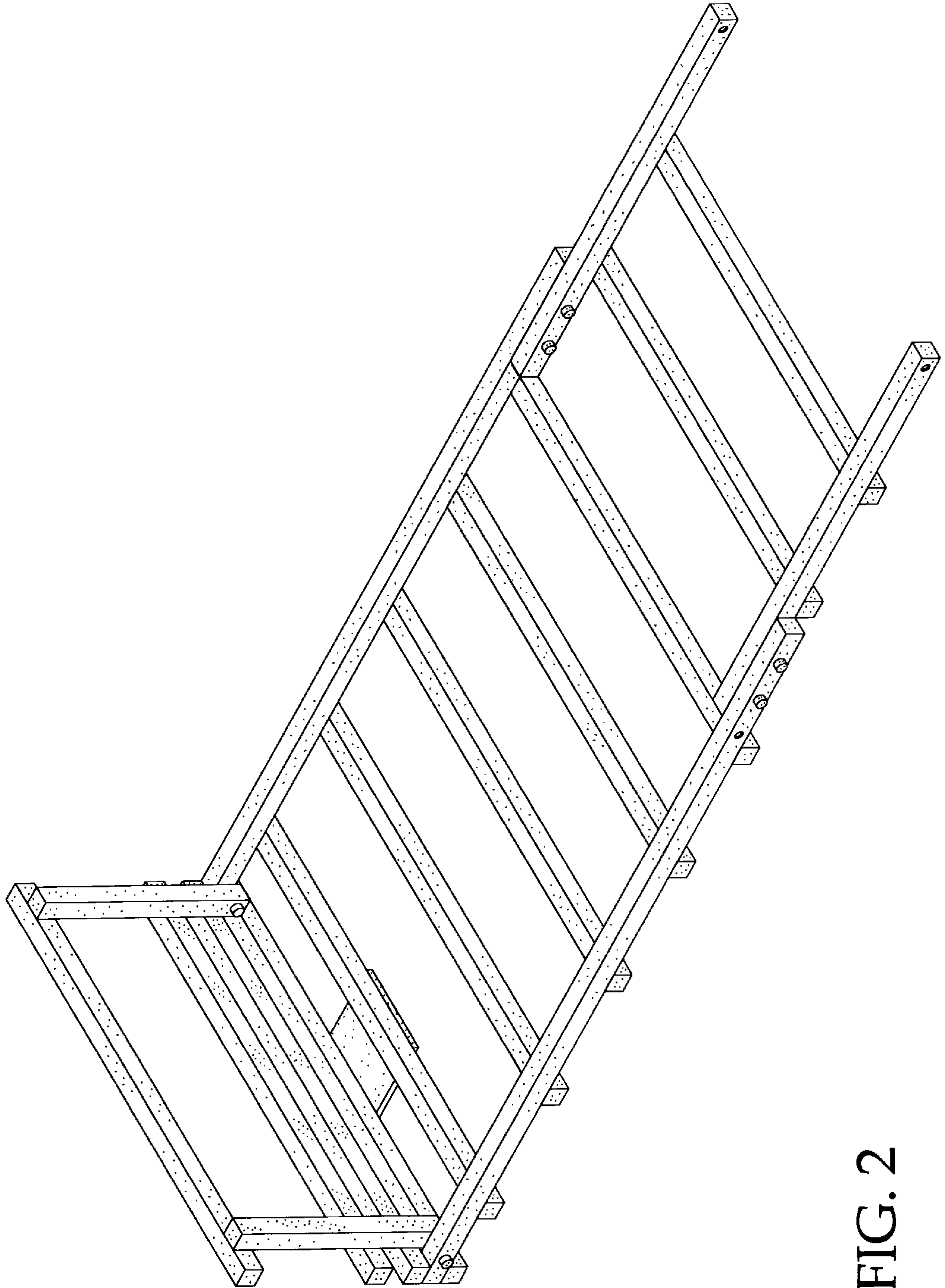

FIG. 2

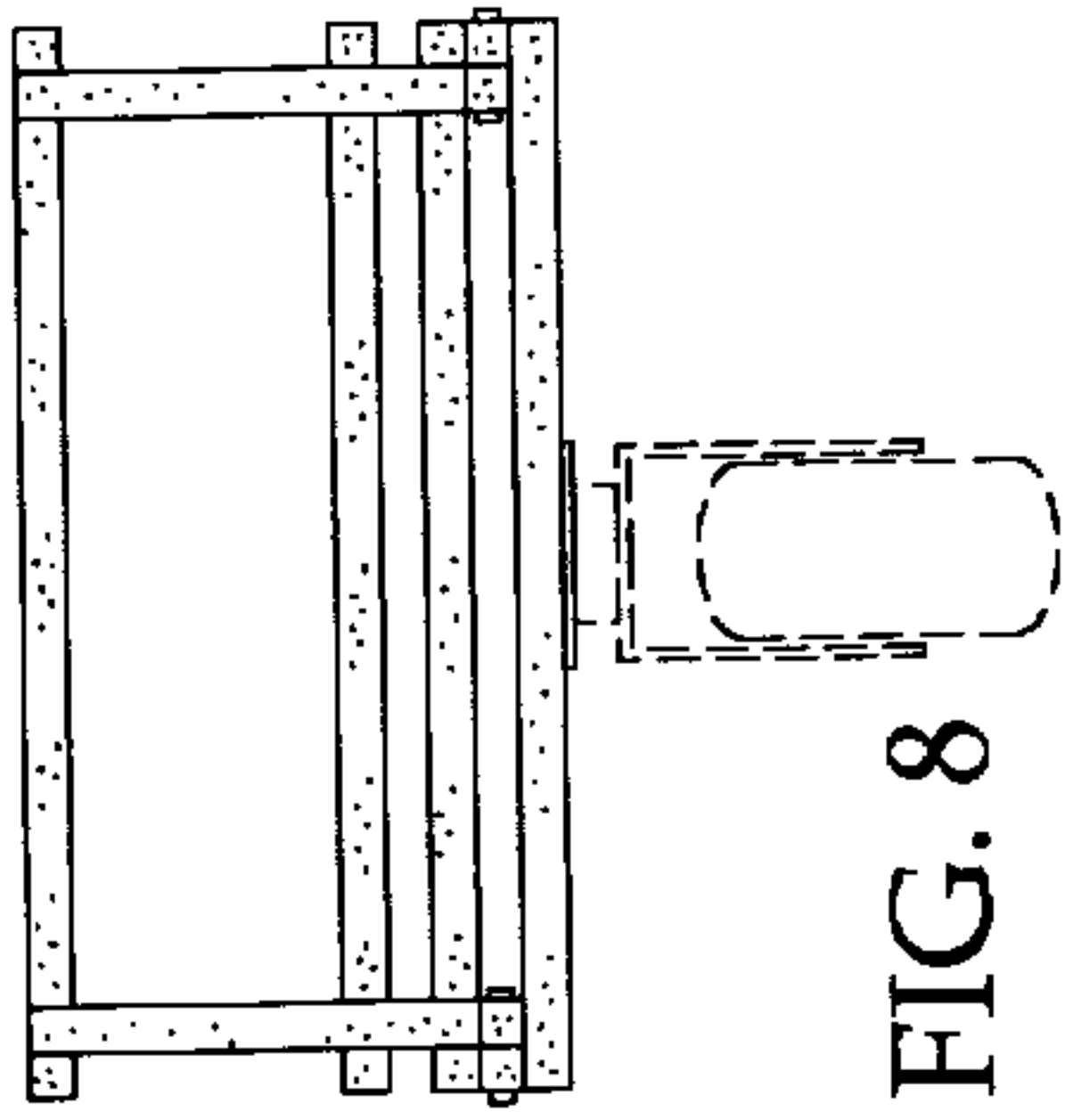

FIG. 8

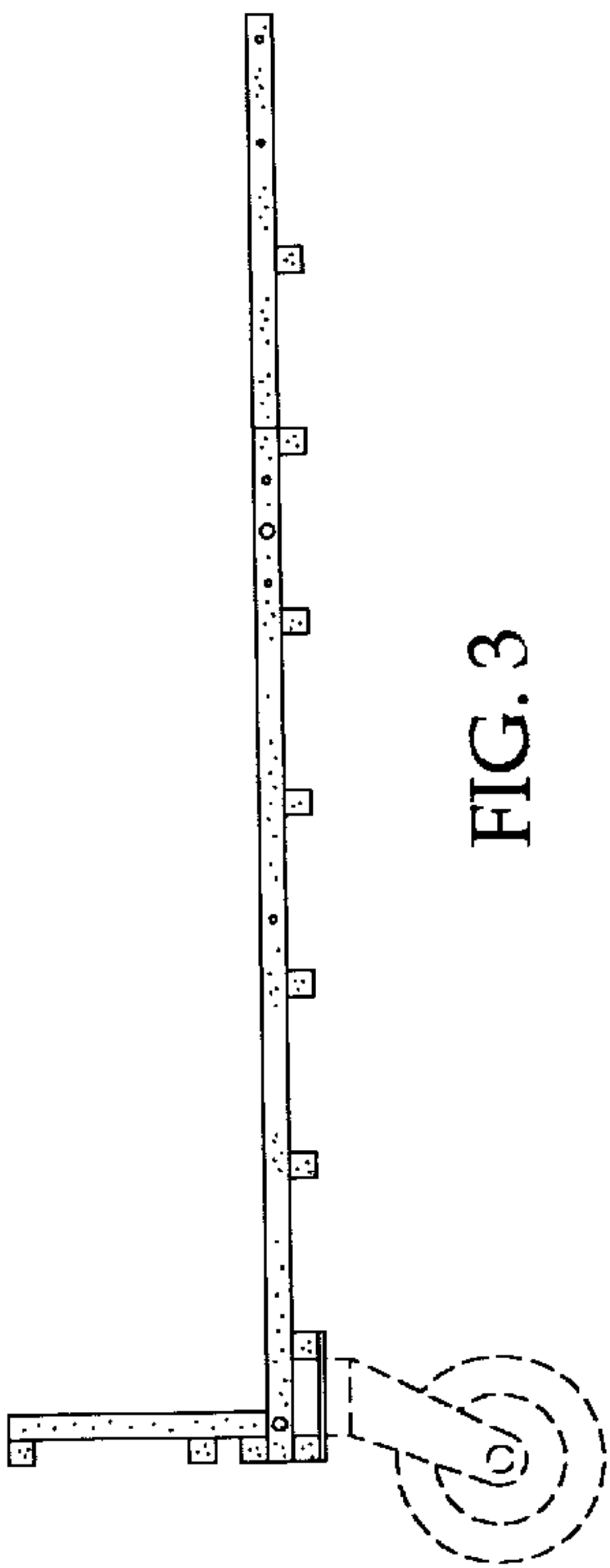

FIG. 3

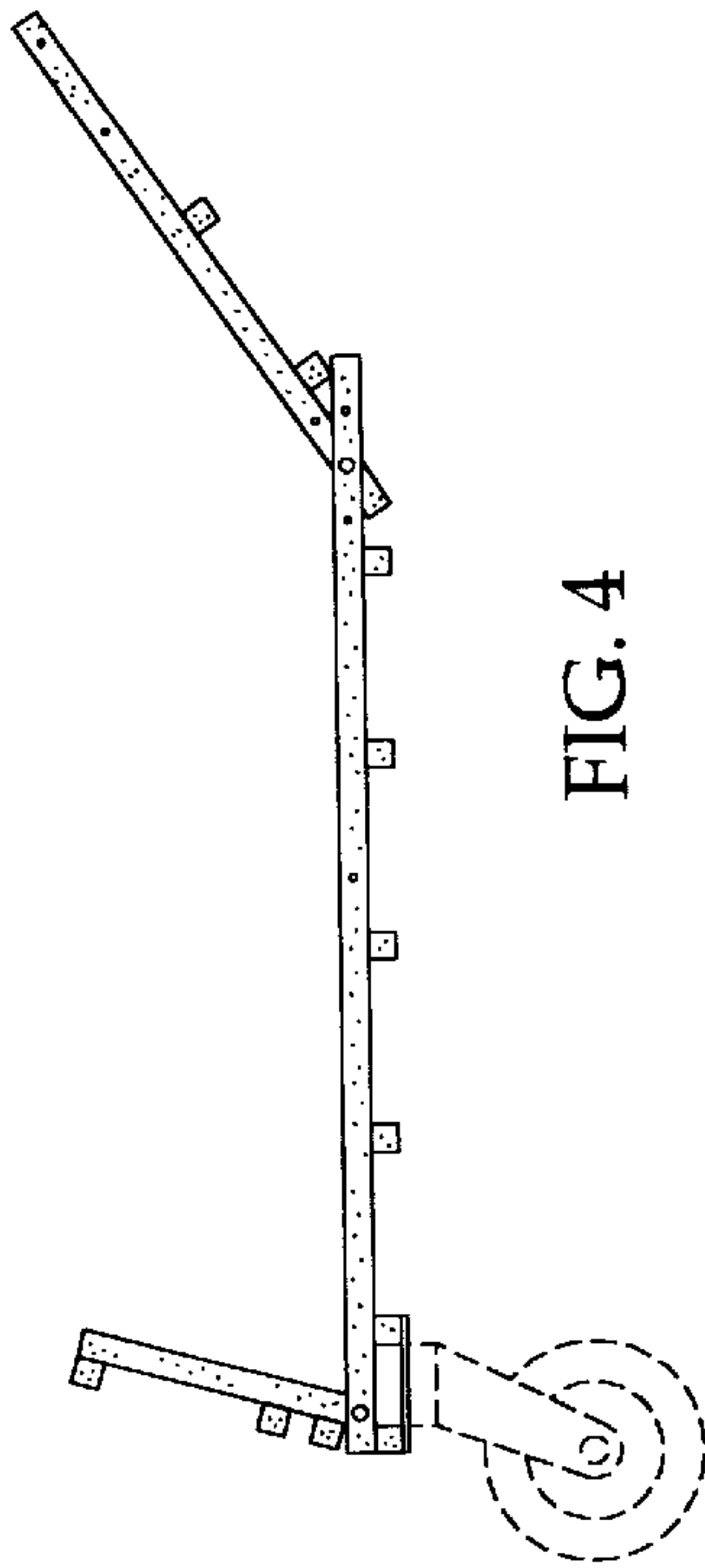

FIG. 4

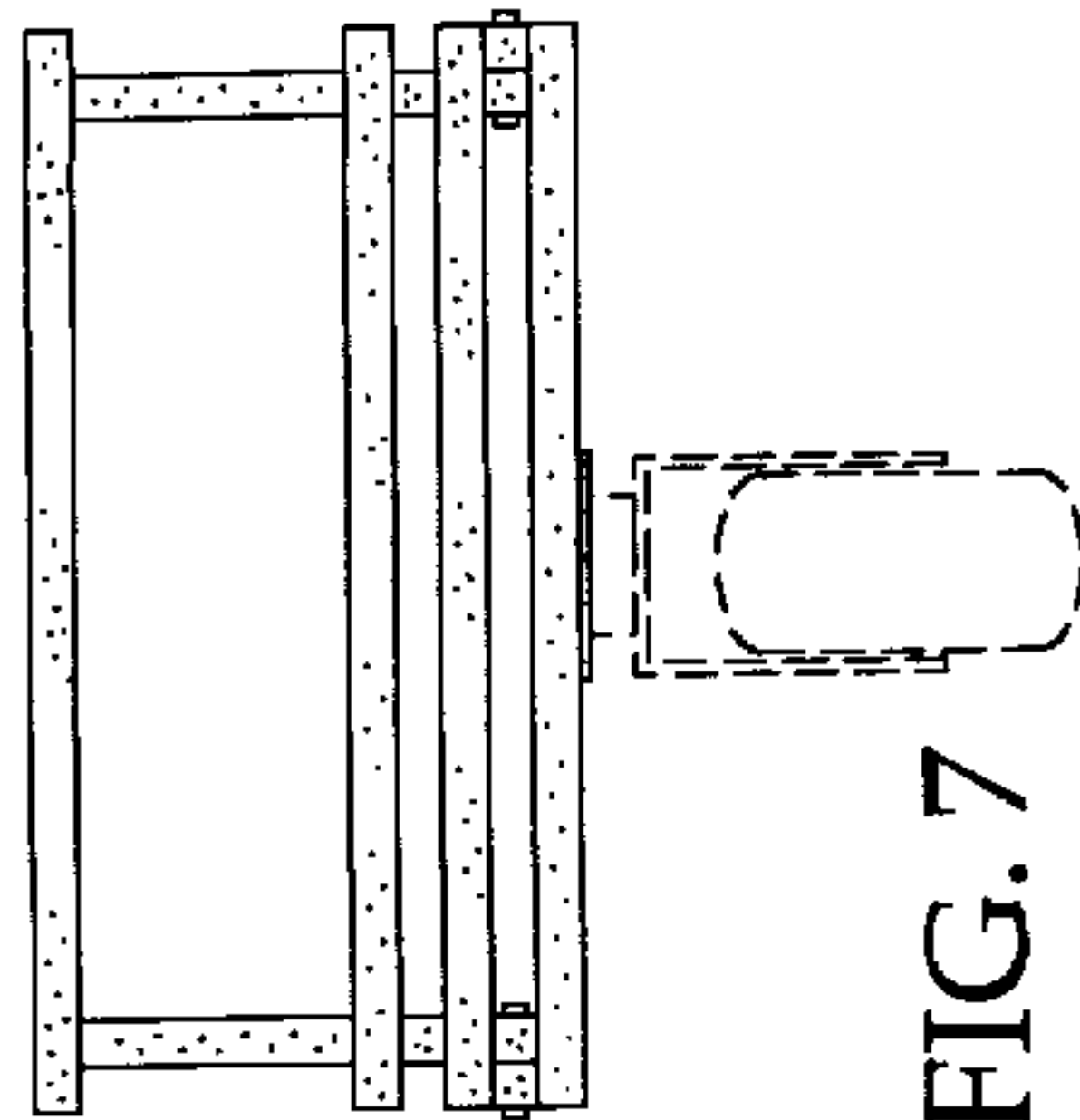

FIG. 7

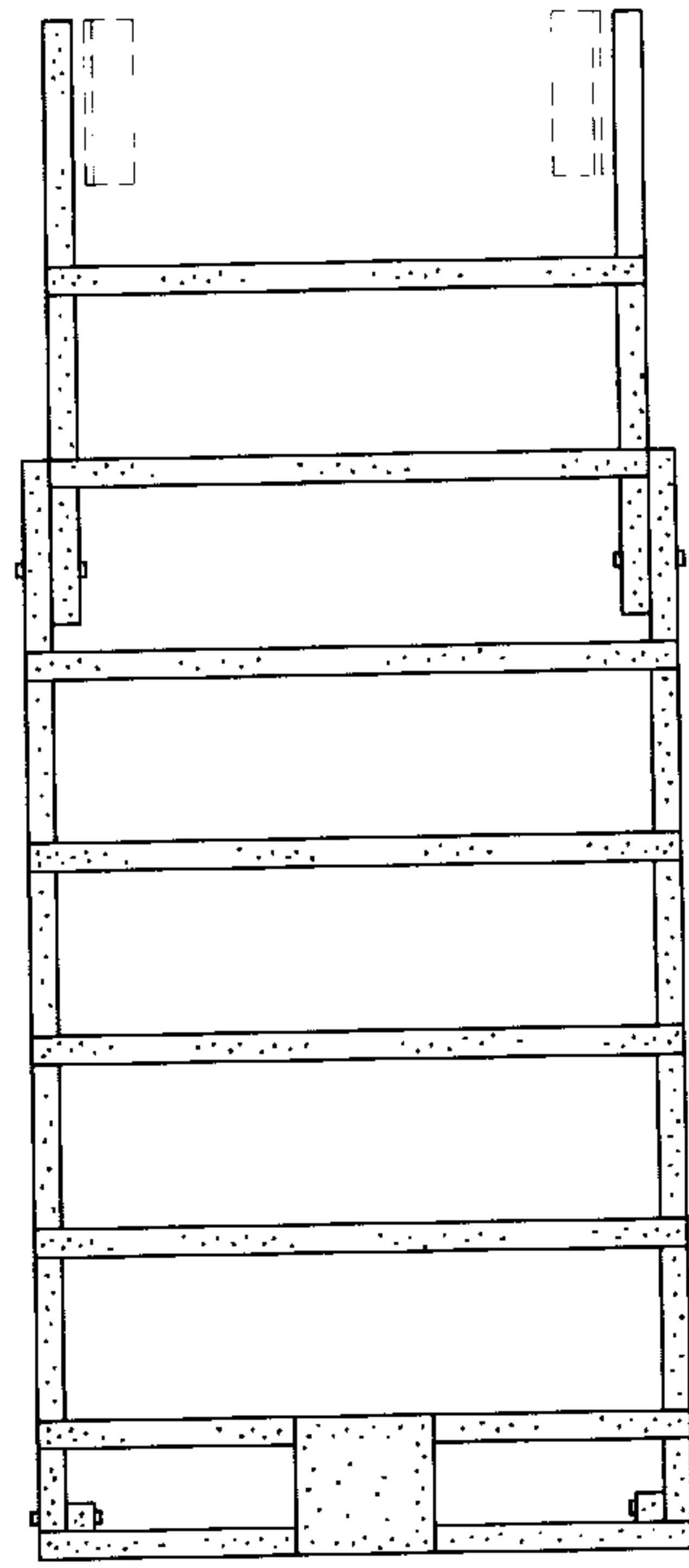

FIG. 6

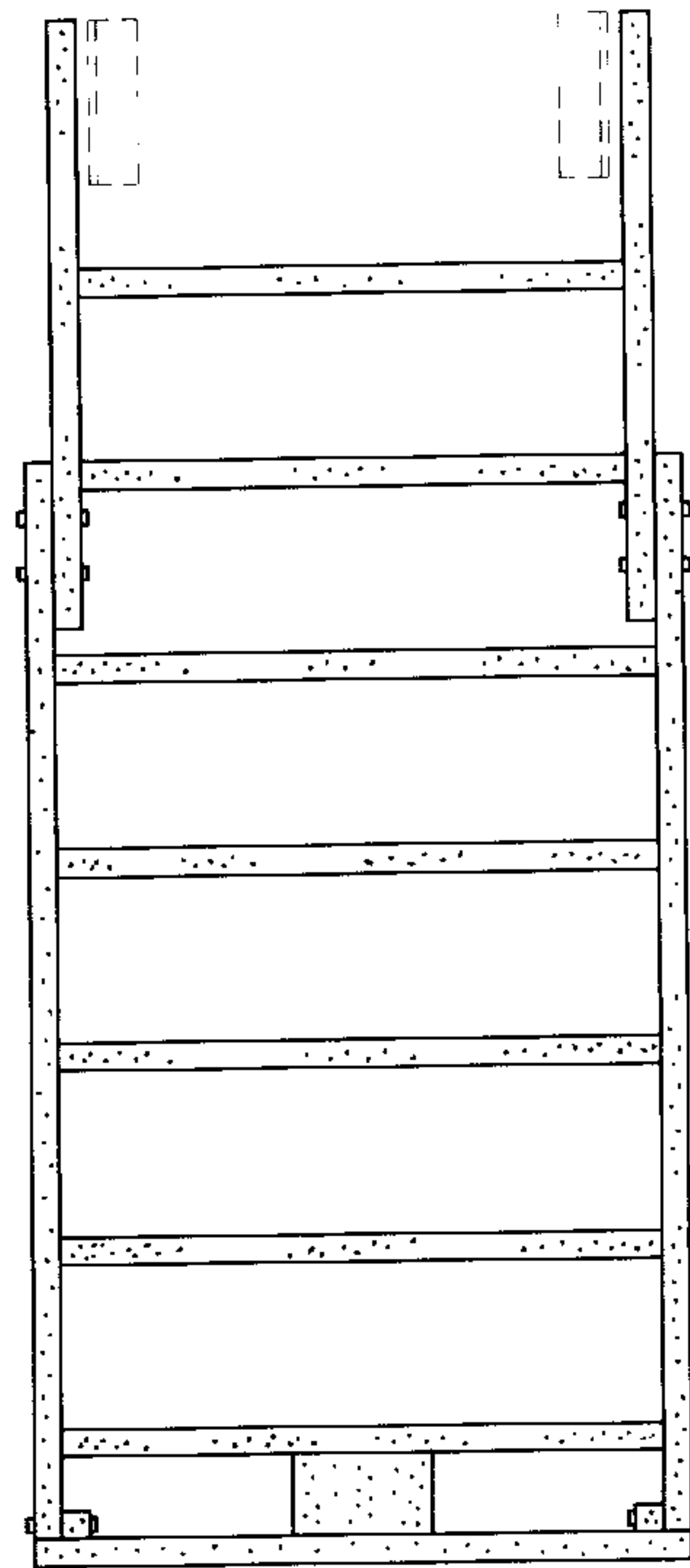

FIG. 5

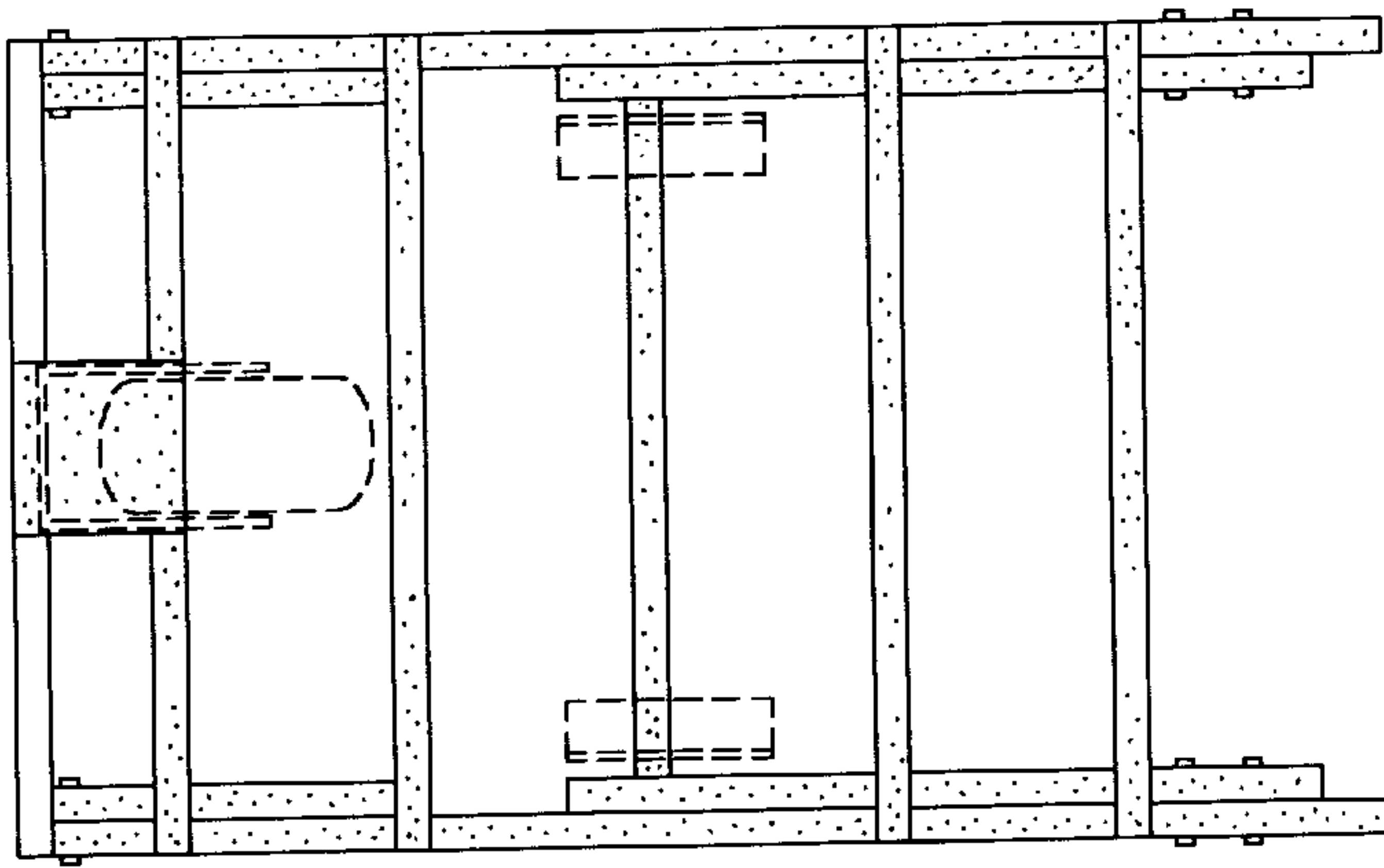

FIG. 11



FIG. 13

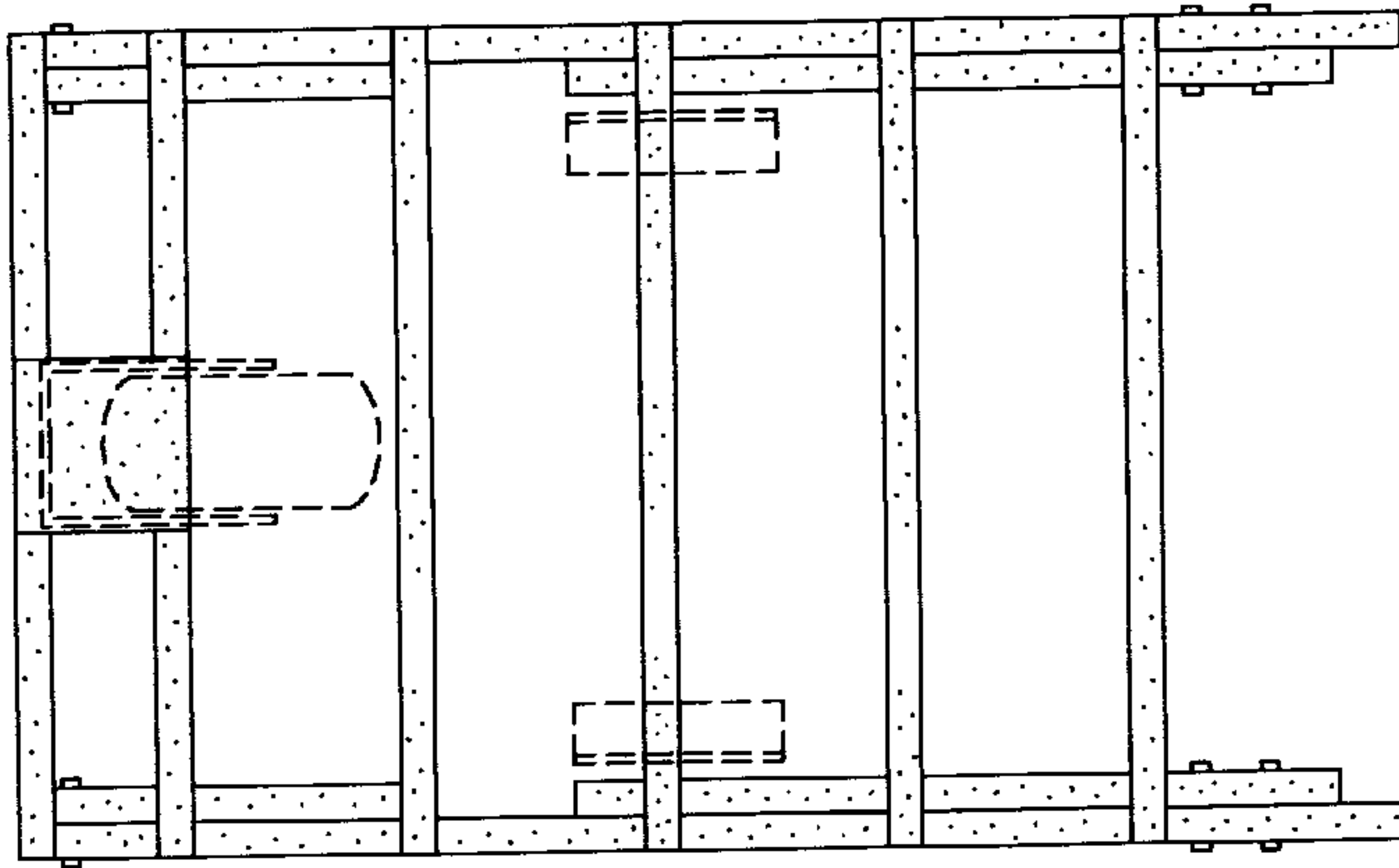

FIG. 10

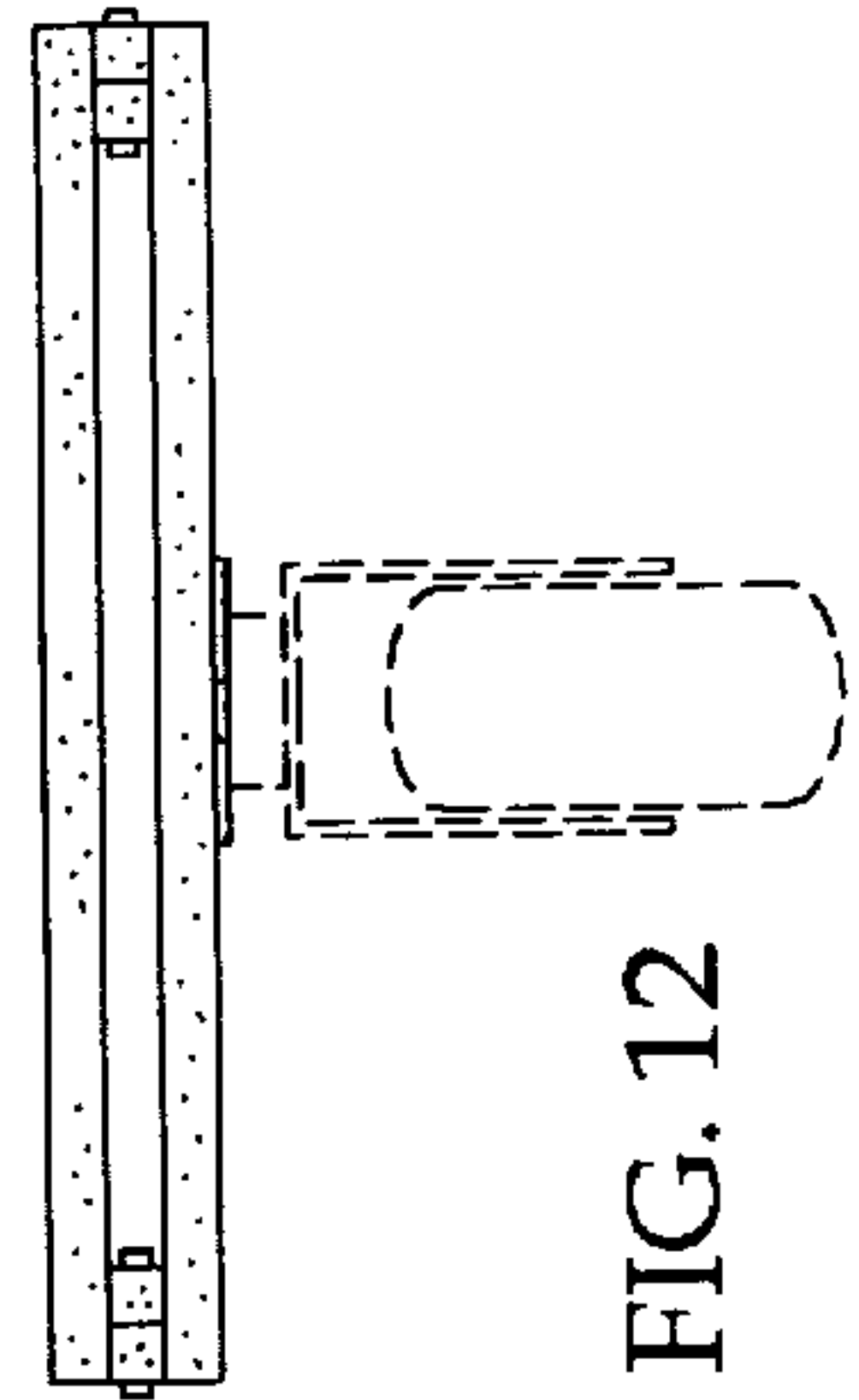

FIG. 12

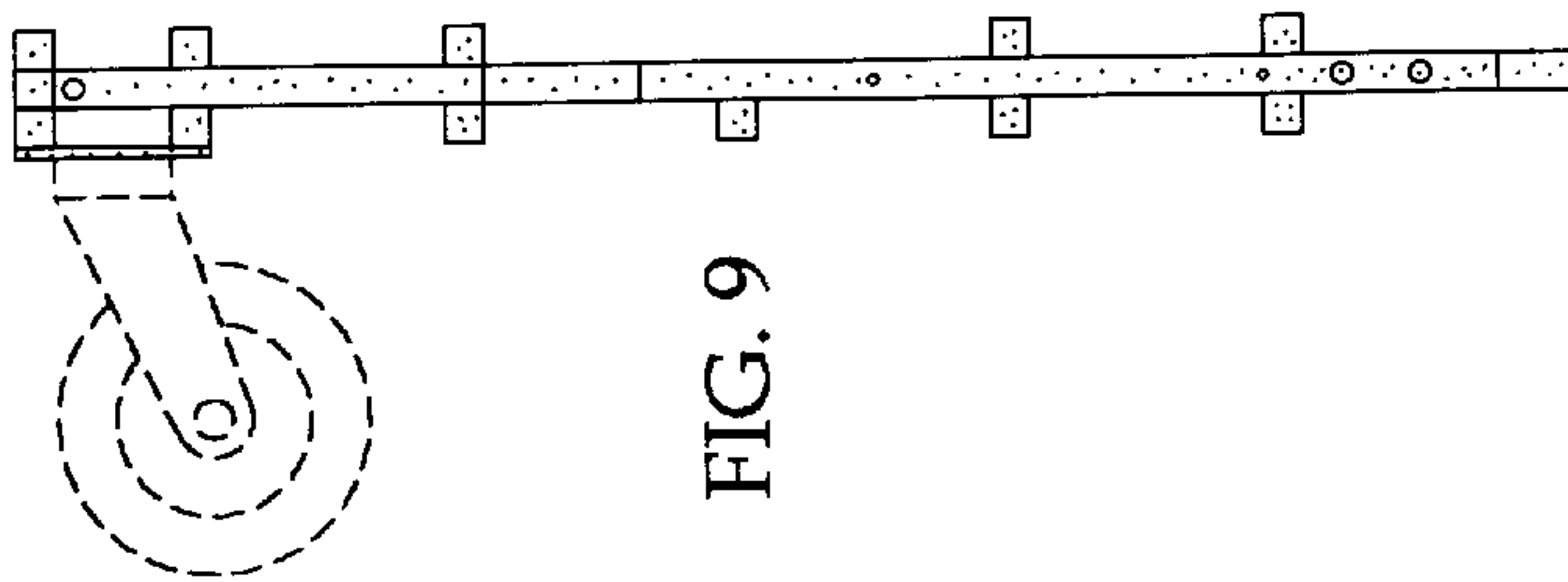

FIG. 9

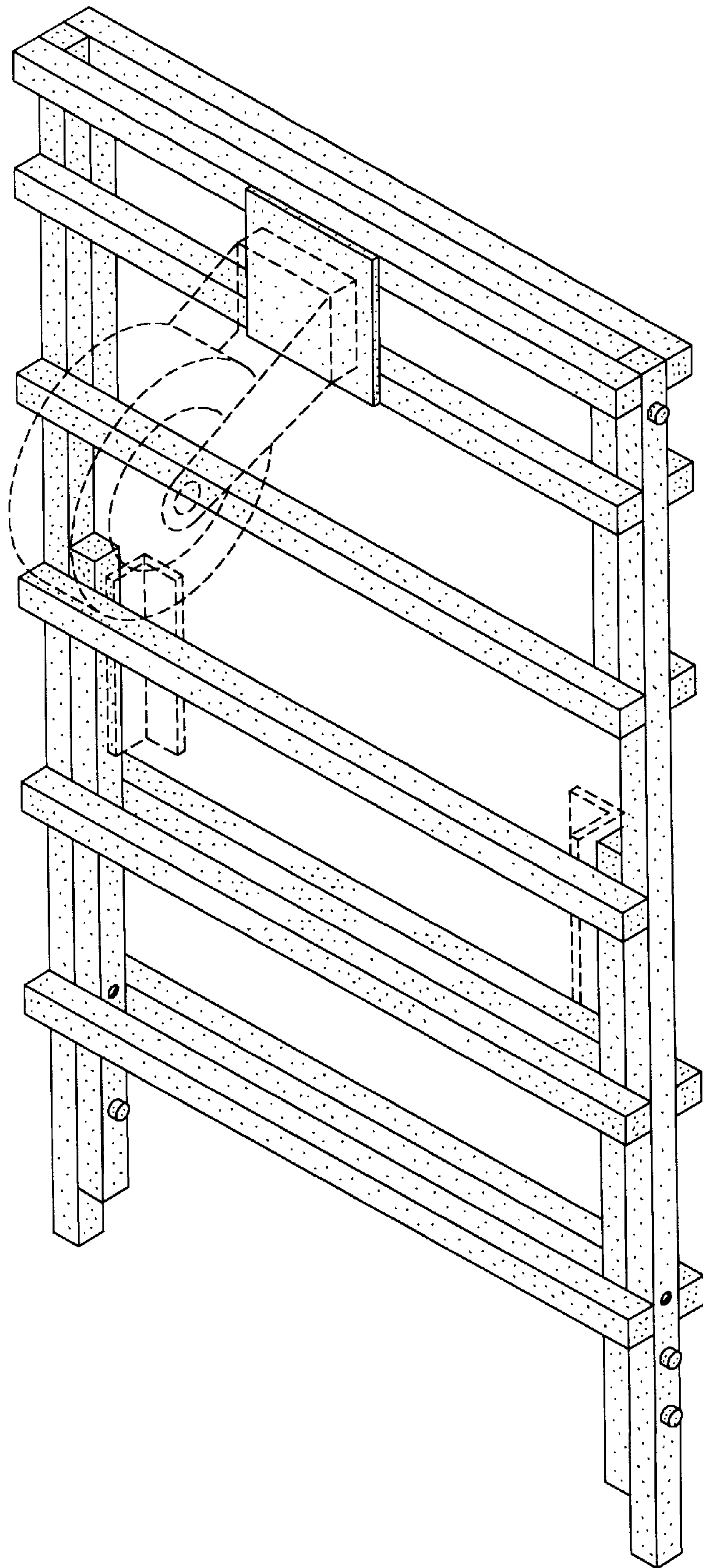

FIG. 14

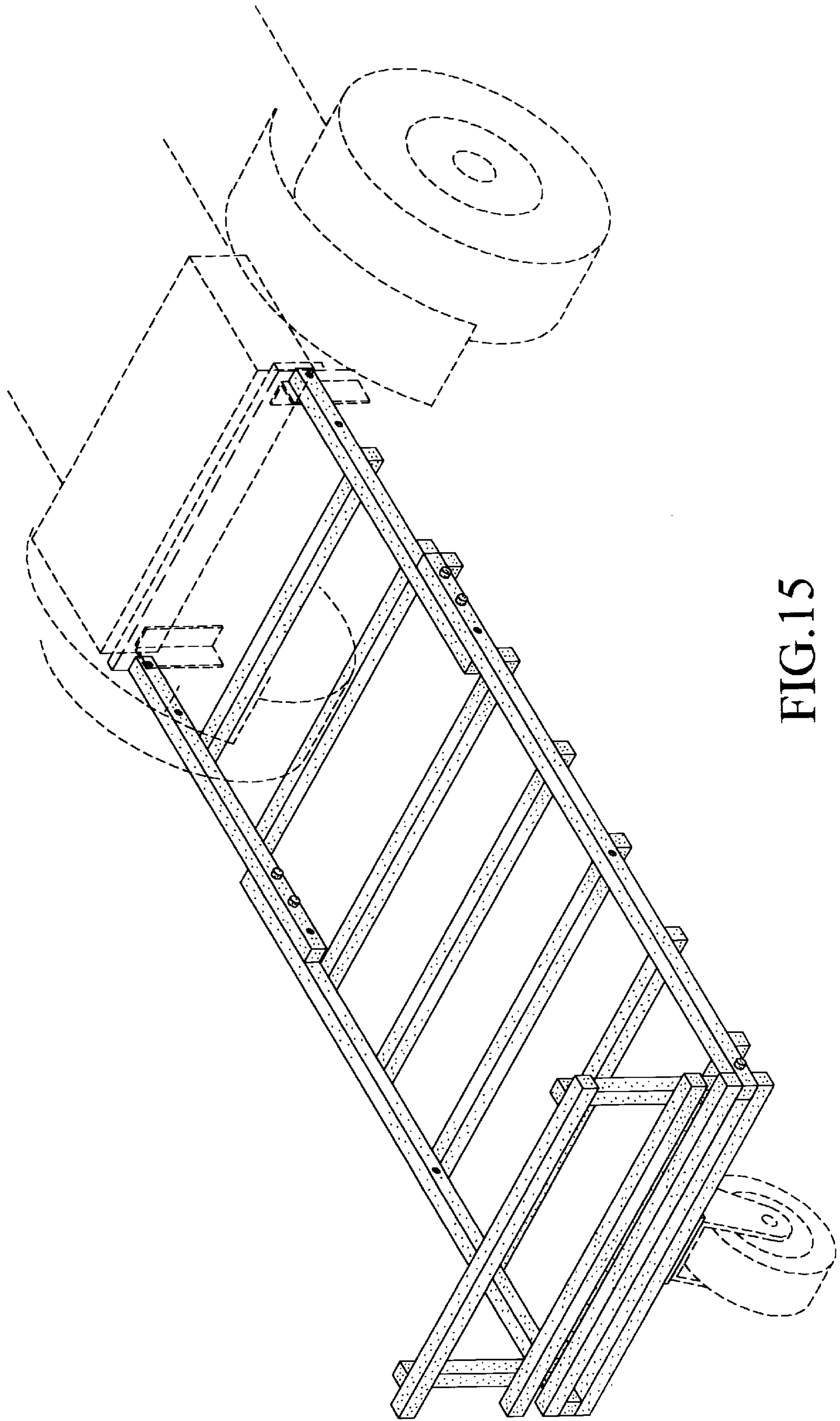

FIG.15

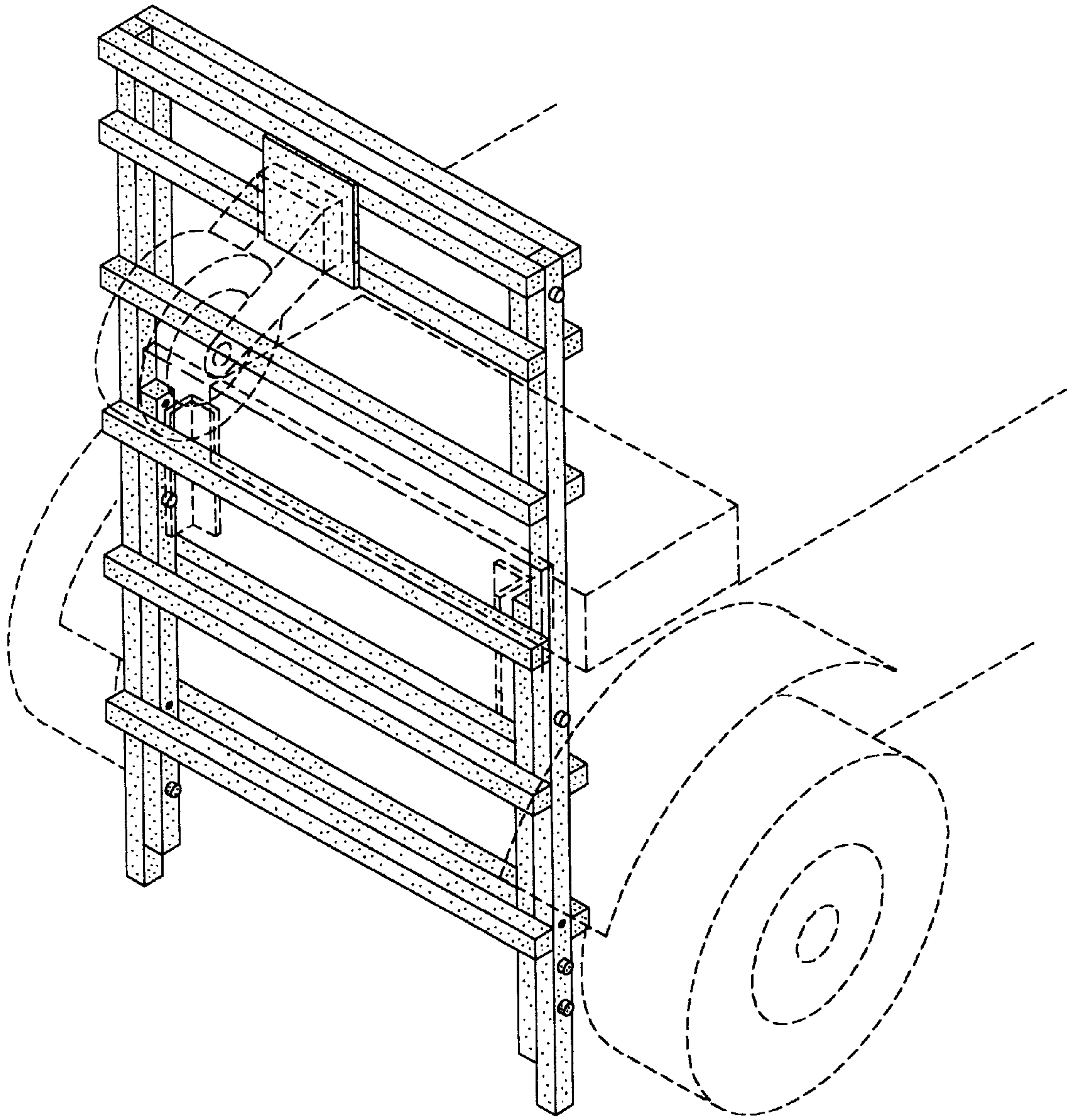

FIG. 16