



US00D417130S

**United States Patent** [19]  
**Hollinger**

[11] **Patent Number: Des. 417,130**

[45] **Date of Patent: \*\* Nov. 30, 1999**

[54] **AUTOMOBILE ESCAPE HAMMER**

5,630,242 5/1997 Oginaezawa ..... 7/144  
5,642,567 7/1997 Lin ..... 30/366  
5,903,942 5/1999 Hasegawa ..... 7/144

[75] Inventor: **Fred Hollinger**, Kings Park, N.Y.

[73] Assignee: **E & B Giftware, Inc.**, Yonkers, N.Y.

[\*\*] Term: **14 Years**

*Primary Examiner*—Philip S. Hyder  
*Attorney, Agent, or Firm*—Stanley J. Yavner

[21] Appl. No.: **29/100,664**

[22] Filed: **Feb. 13, 1999**

[57] **CLAIM**

The ornamental design for an automobile escape hammer, as shown and described.

[51] **LOC (6) Cl.** ..... **08-02**

[52] **U.S. Cl.** ..... **D8/81; D8/75; D8/105**

[58] **Field of Search** ..... D8/105, 75, 79,  
D8/80, 81, 82, 98; 81/21, 22; 7/138, 142,  
143, 144, 145, 158, 165; 30/366

**DESCRIPTION**

FIG. 1 is a right side, front and top isometric view of an automobile escape hammer showing my new design, with the needle structure extended; and the needle structure not being extended in the other figures hereof;

FIG. 2 is a top plan view thereof;

FIG. 3 is a front, elevational view thereof;

FIG. 4 is a right side elevational view thereof;

FIG. 5 is a left side elevational view thereof;

FIG. 6 is a rear elevational view thereof; and,

FIG. 7 is a bottom plan view thereof.

[56] **References Cited**

**U.S. PATENT DOCUMENTS**

D. 290,334	6/1987	Reynolds, Jr.	.....	D8/105
D. 324,805	3/1992	Pease	.....	D8/105
D. 385,771	11/1997	Chiang	.....	D8/105
4,592,467	6/1986	Lechner	.....	7/144

**1 Claim, 3 Drawing Sheets**

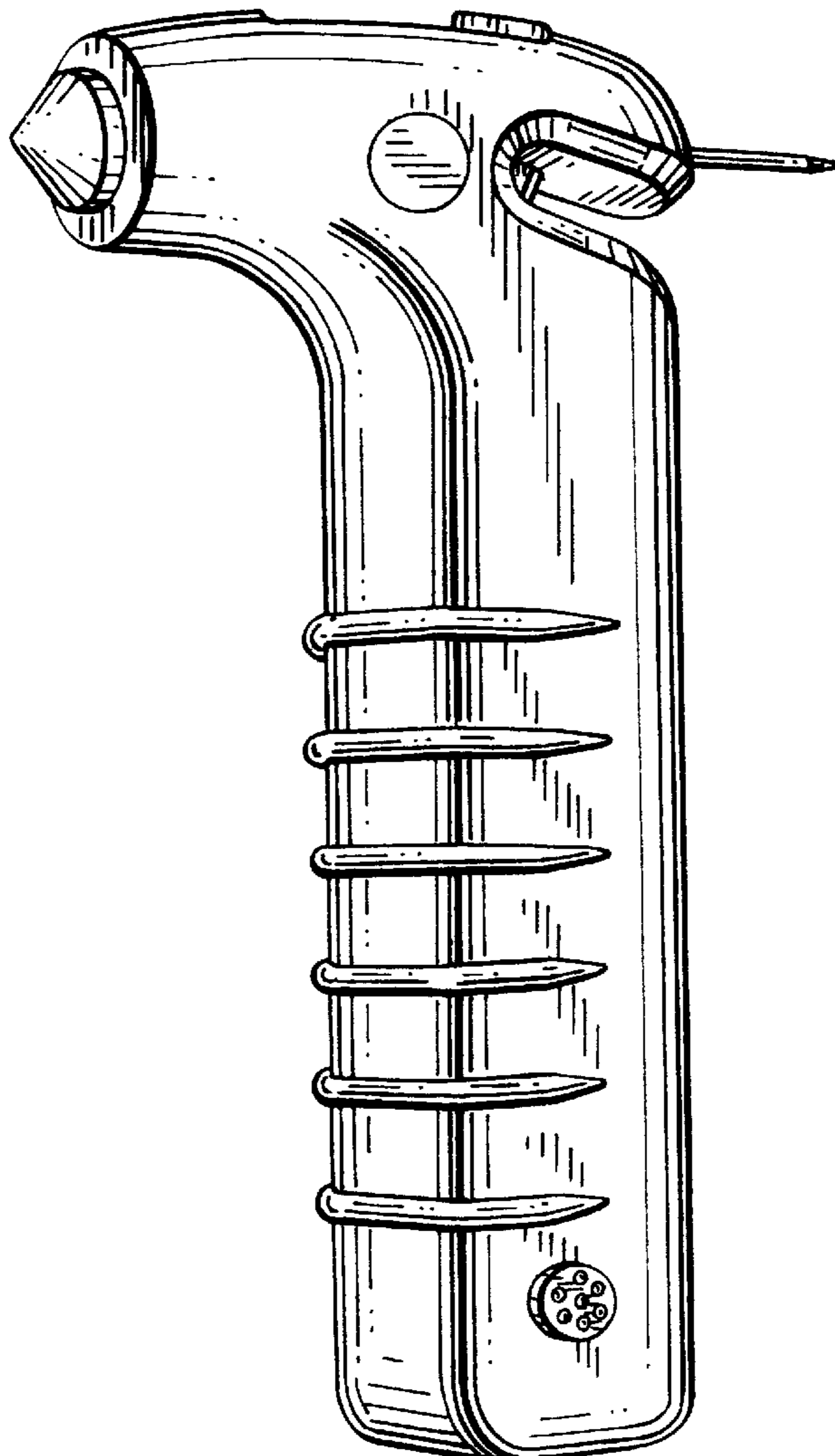

FIG. 1

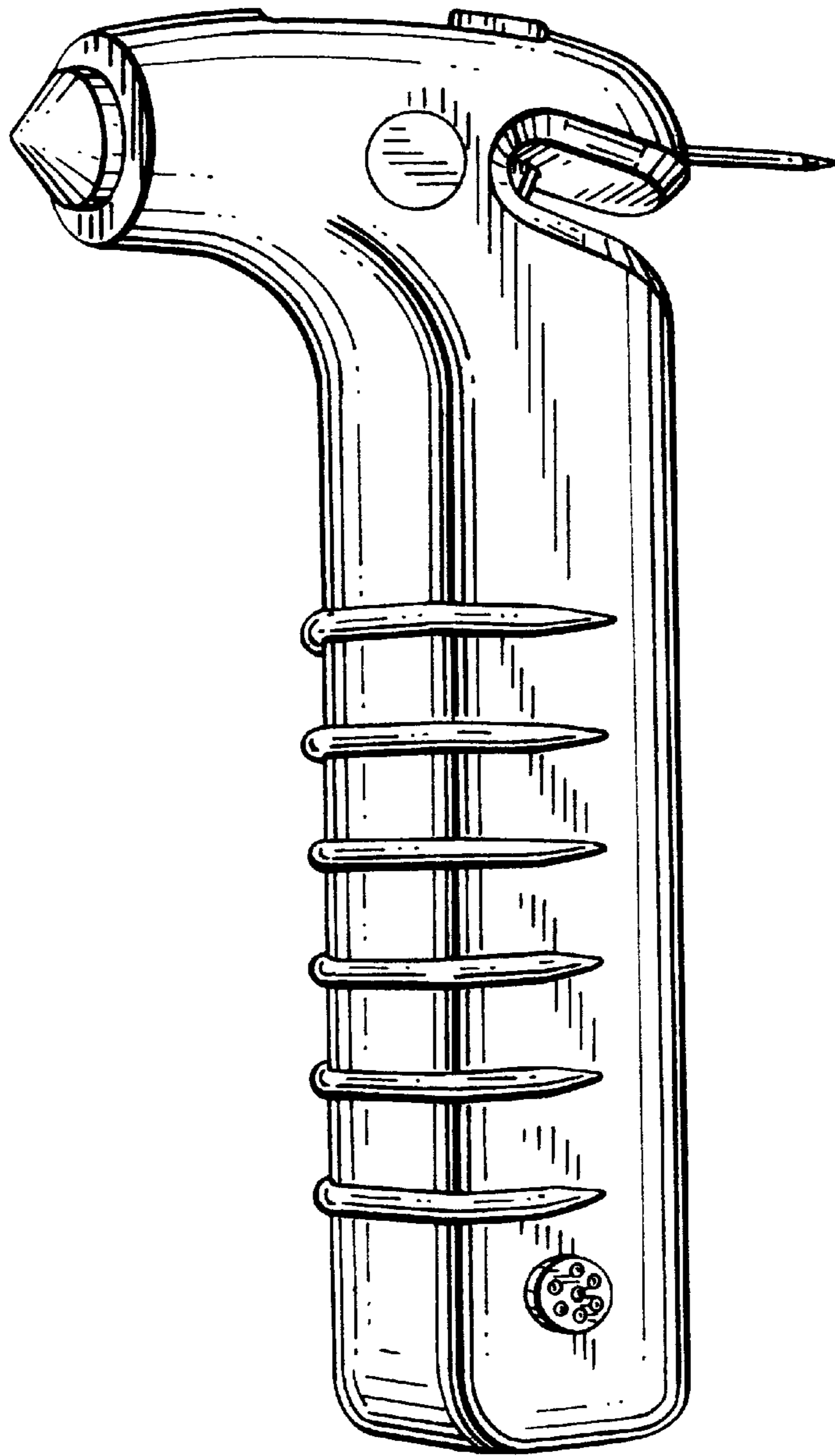

FIG. 2

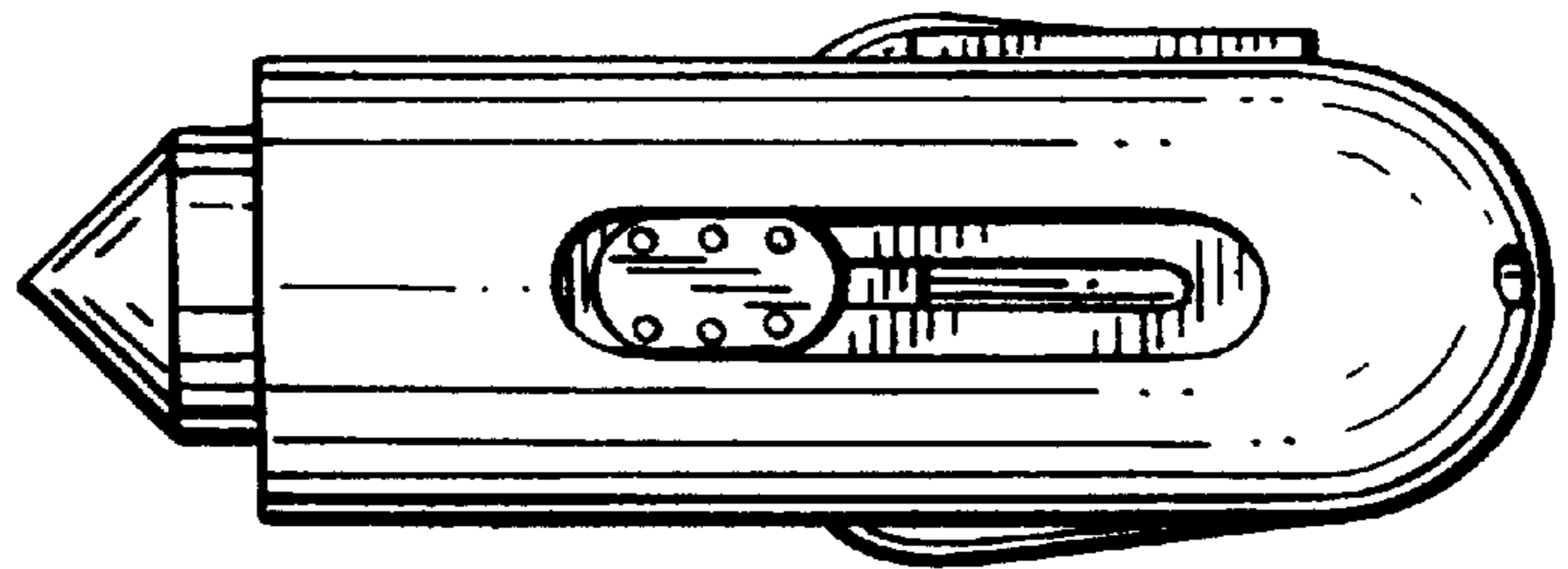

FIG. 3

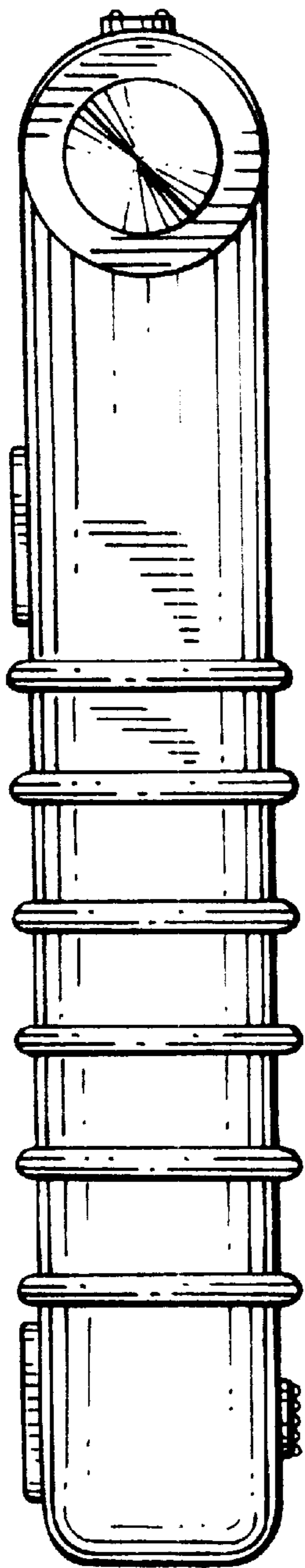

FIG. 4

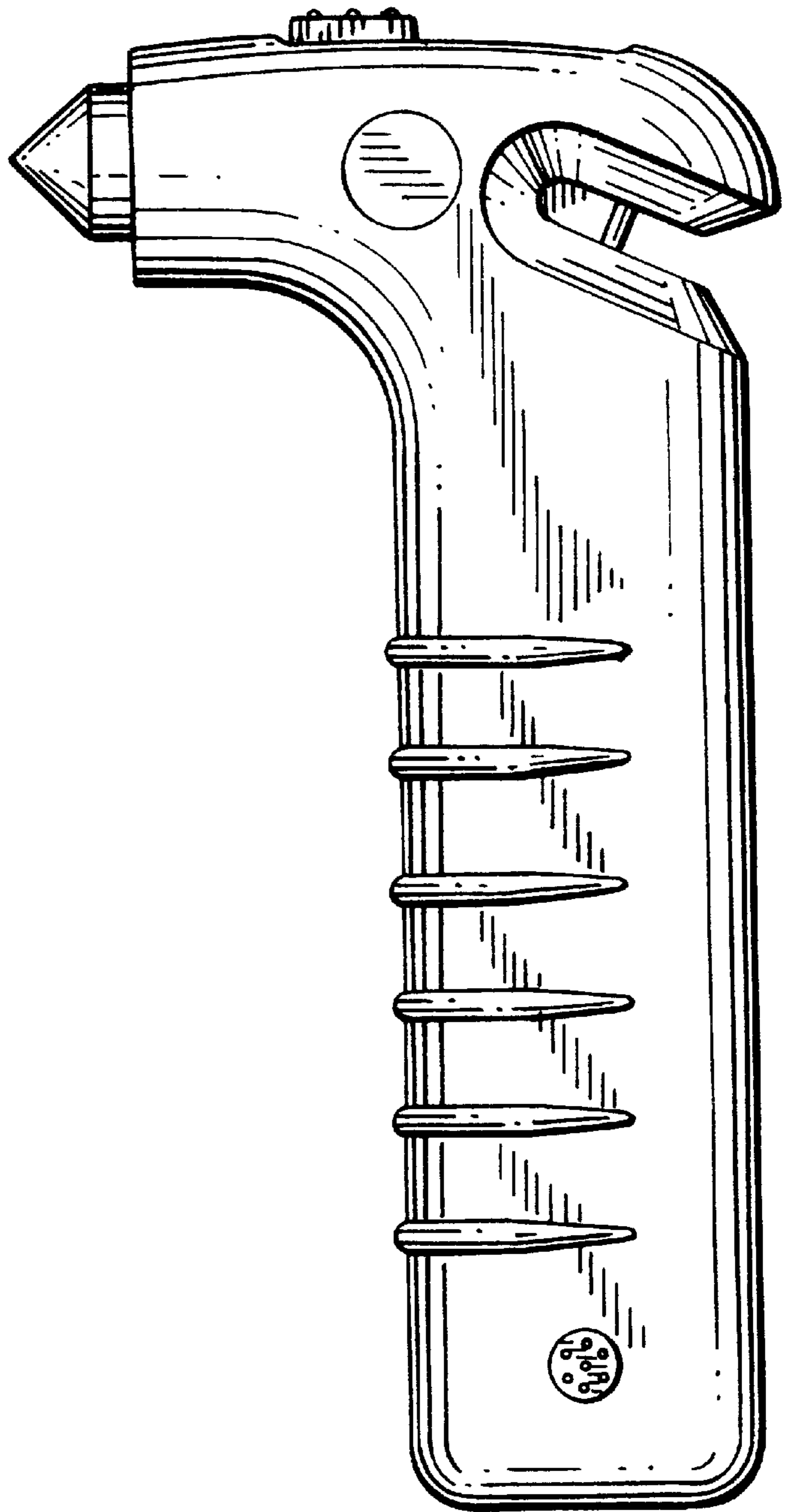

FIG. 5

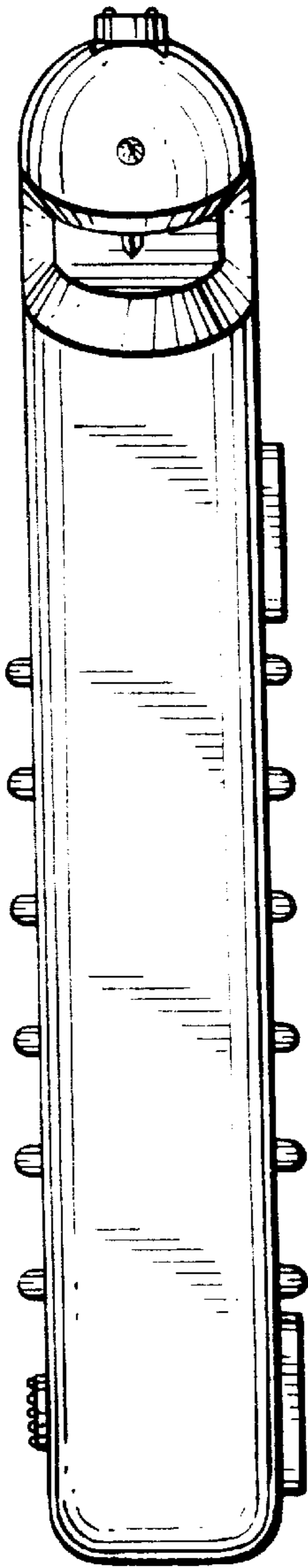
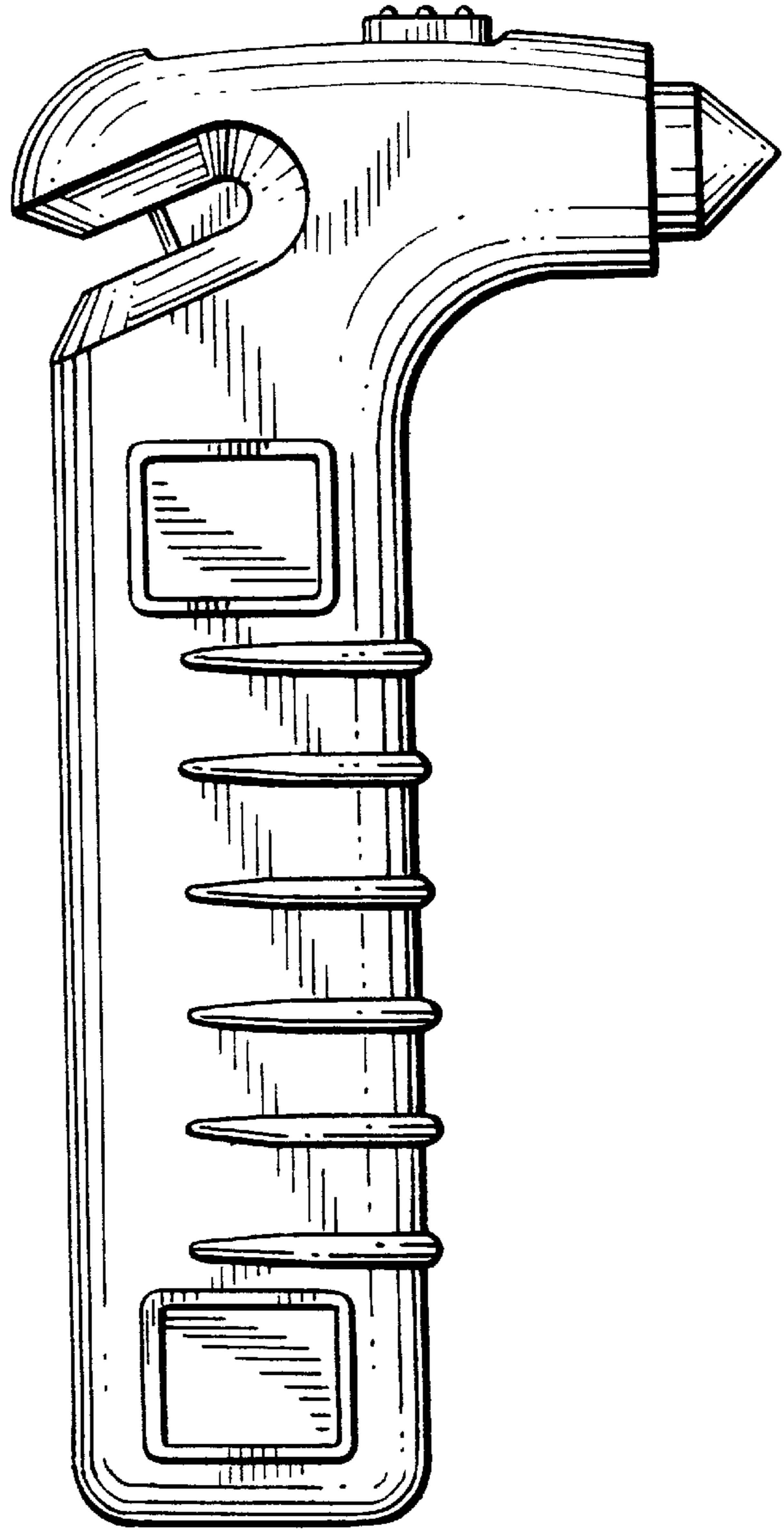

FIG. 6

FIG. 7

