



US00D416935S

United States Patent [19] DeCola

[11] Patent Number: Des. 416,935

[45] Date of Patent: ** Nov. 23, 1999

[54] **GUITAR PEGHEAD**

[75] Inventor: **James B. DeCola**, Meridian, Miss.

[73] Assignee: **Peavey Electronics Corporation**, Meridian, Miss.

[**] Term: **14 Years**

[21] Appl. No.: **29/090,835**

[22] Filed: **Jul. 17, 1998**

Related U.S. Application Data

[62] Division of application No. 29/064,837, Jan. 10, 1997, Pat. No. Des. 404,060.

[51] **LOC (6) Cl.** **17-03**

[52] **U.S. Cl.** **D17/20**

[58] **Field of Search** D17/14, 15, 18-20; 84/267, 291, 293, 304

[56] References Cited

U.S. PATENT DOCUMENTS

D. 207,426	4/1967	Ludwick	D17/20
D. 255,460	6/1980	Todd, III	D17/20
D. 276,441	11/1984	Berardi et al.	D17/14
D. 277,765	2/1985	Sugai	D17/20
D. 300,538	4/1989	Powers et al.	D17/20
4,951,542	8/1990	Chen	84/293
5,452,637	9/1995	DeCola	84/291

OTHER PUBLICATIONS

Trademark, Reg. No. 1,138,967, Aug. 1980.

Primary Examiner—Adir Aronovich
Attorney, Agent, or Firm—Watson Cole Grindle Watson P.L.L.C.

[57] CLAIM

The ornamental design for a guitar peghead, as shown and described.

DESCRIPTION

FIG. 1 is a top plan view of a guitar peghead showing my new design;

FIG. 2 is a bottom view thereof;

FIG. 3 is a side view of the guitar peghead viewed from the left side of FIG. 1;

FIG. 4 is a side view of the peghead according to the invention viewed from the right side of FIG. 1;

FIG. 5 is an end view of the guitar peghead viewed from the top of FIG. 1;

FIG. 6 is an end view of the guitar peghead viewed from the bottom of FIG. 1;

FIG. 7 is a top view of another embodiment of the guitar peghead according to the present invention;

FIG. 8 is a bottom view of the guitar peghead shown in FIG. 7;

FIG. 9 is a side view of the guitar peghead viewed from the left in FIG. 7;

FIG. 10 is a side view of the guitar peghead viewed from the right in FIG. 7;

FIG. 11 is an end view of the guitar peghead viewed from the top of FIG. 7; and,

FIG. 12 is an end view of the guitar peghead viewed from the bottom of FIG. 7, guitar neck and tuning machines are shown in dotted line.

The broken lines are shown for illustrative purposes only and form no part of the claimed design.

1 Claim, 2 Drawing Sheets

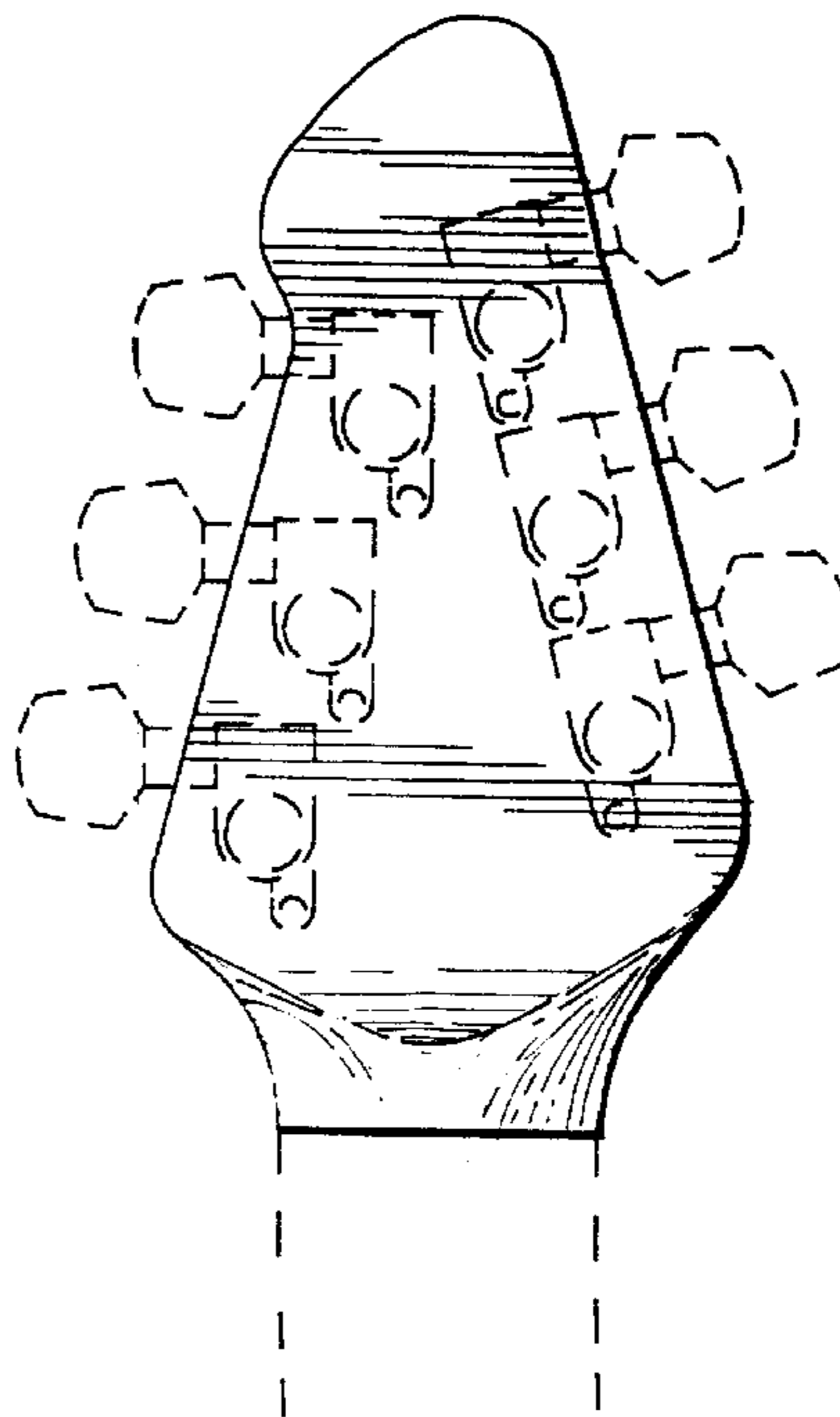
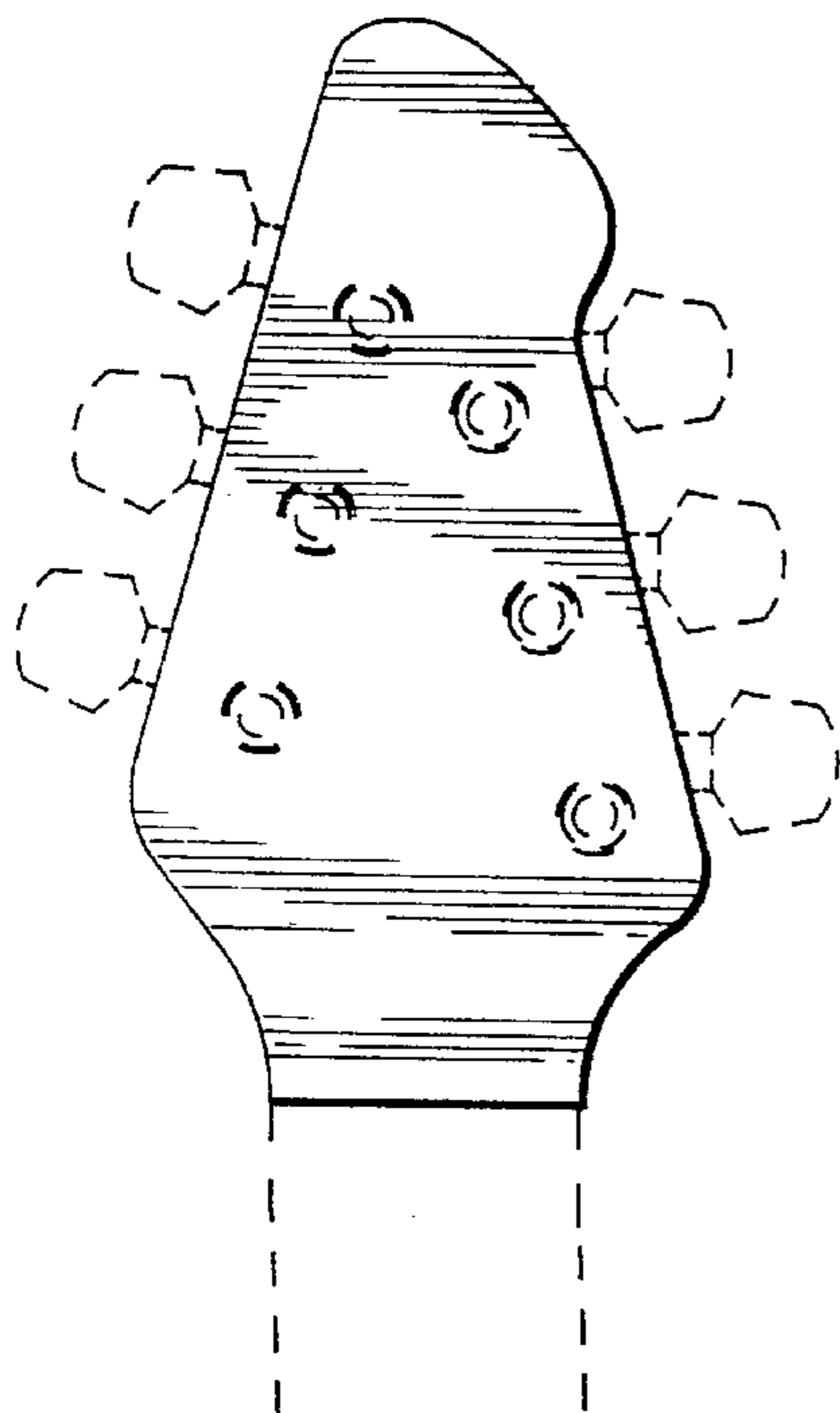

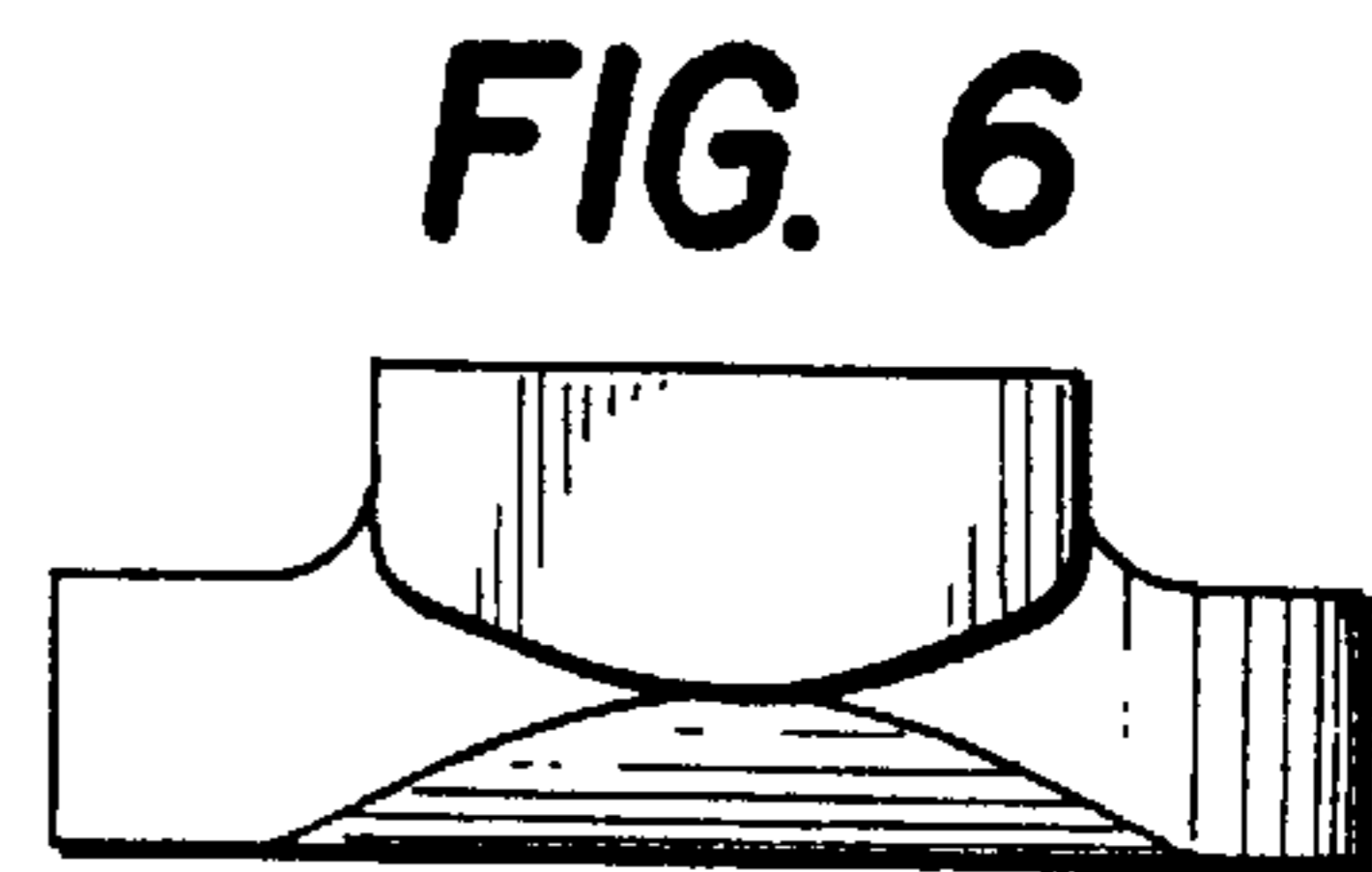
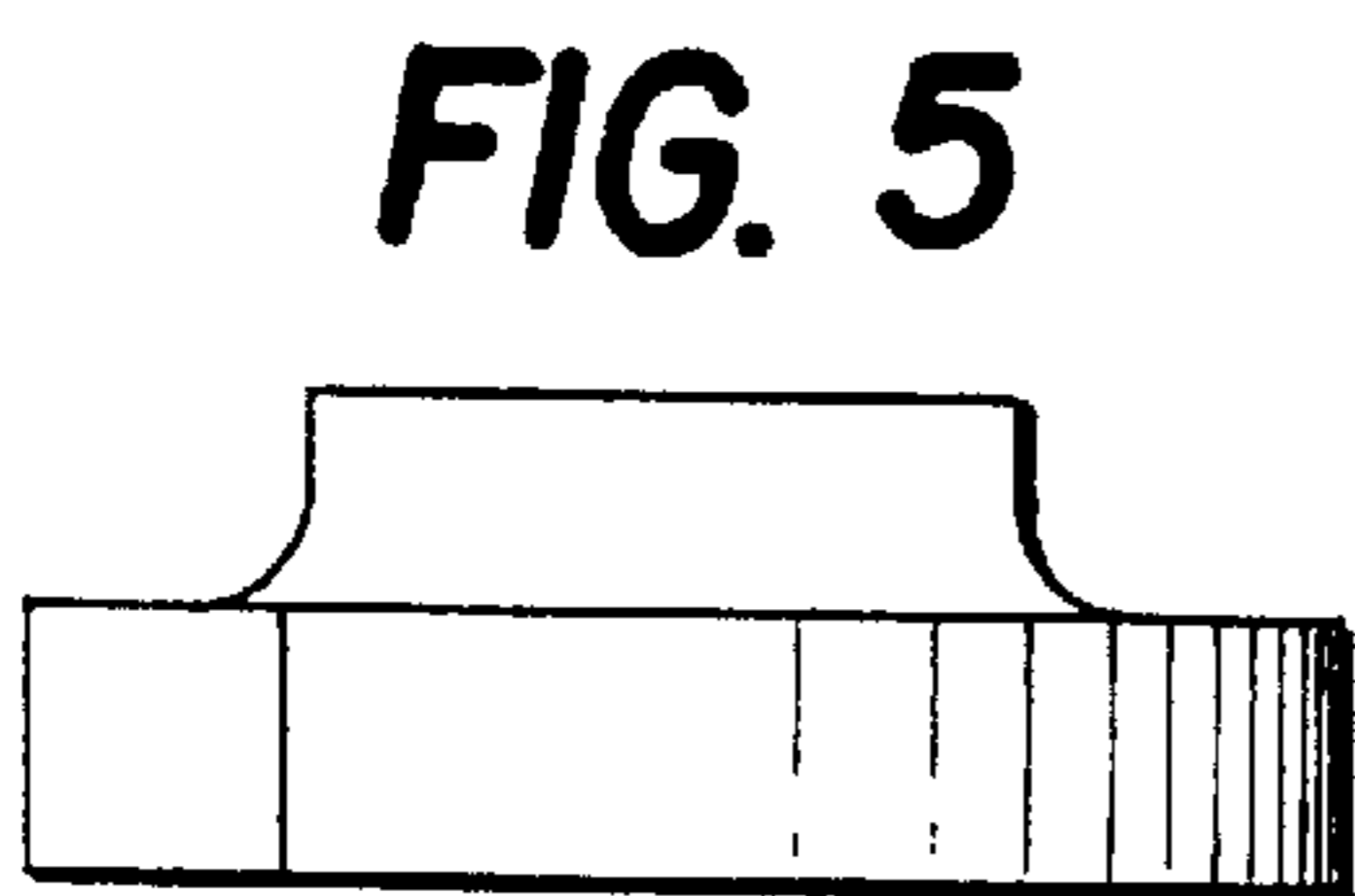
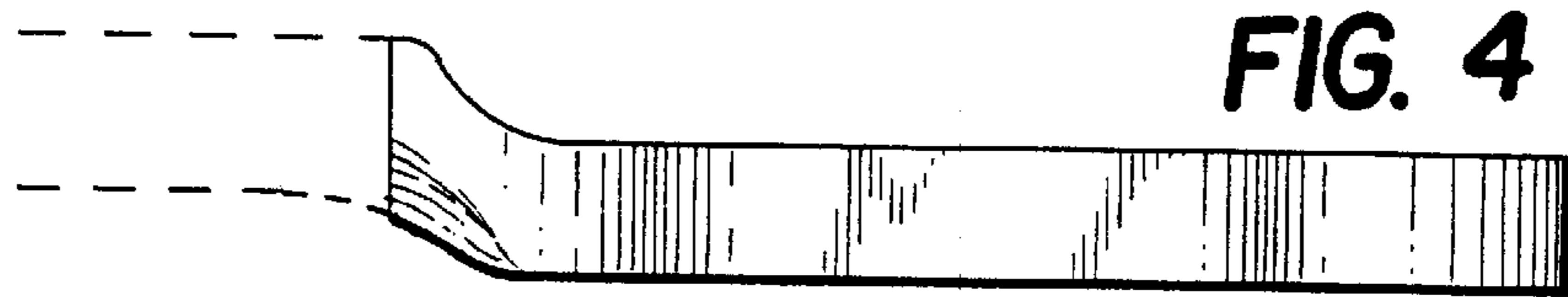
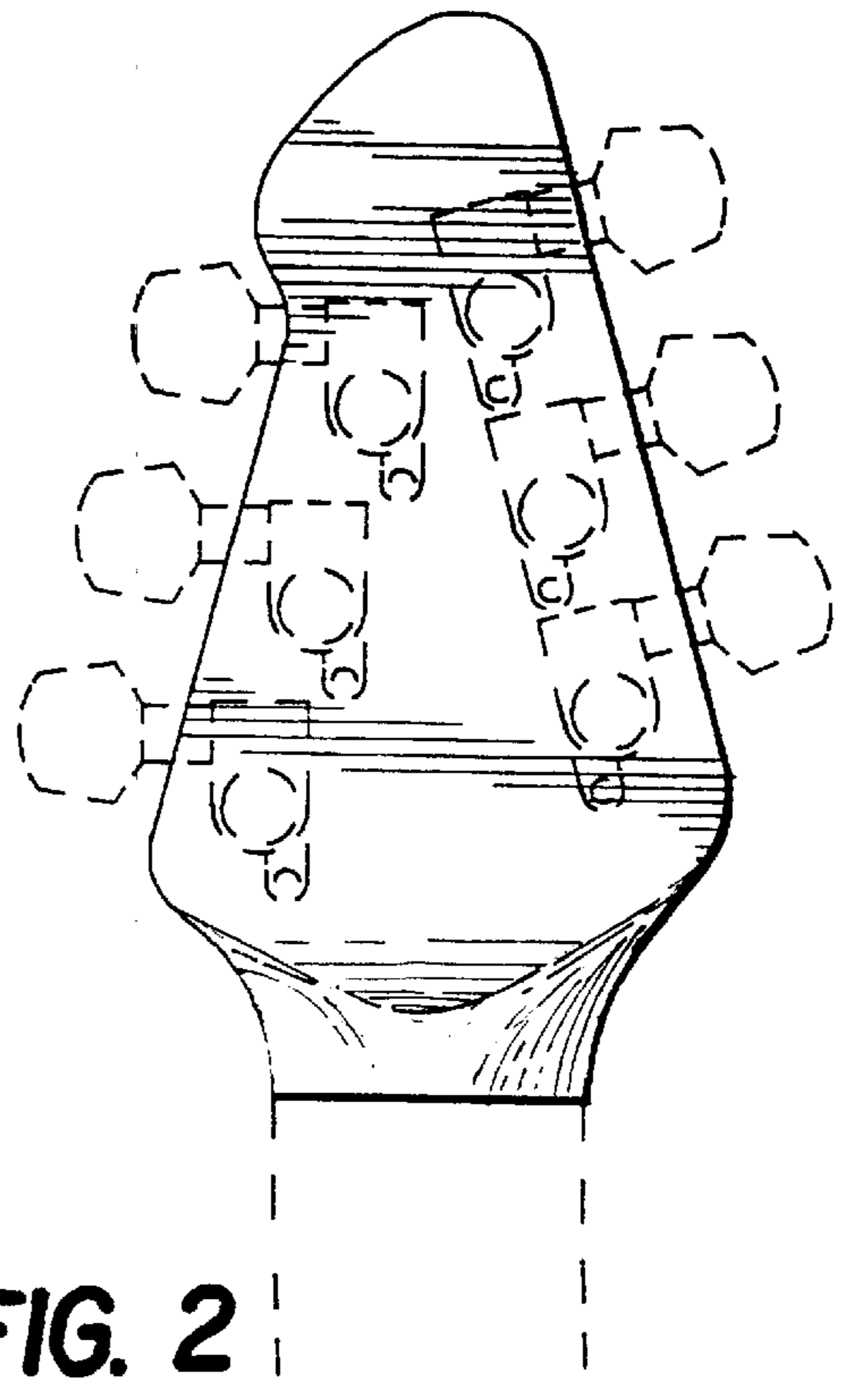
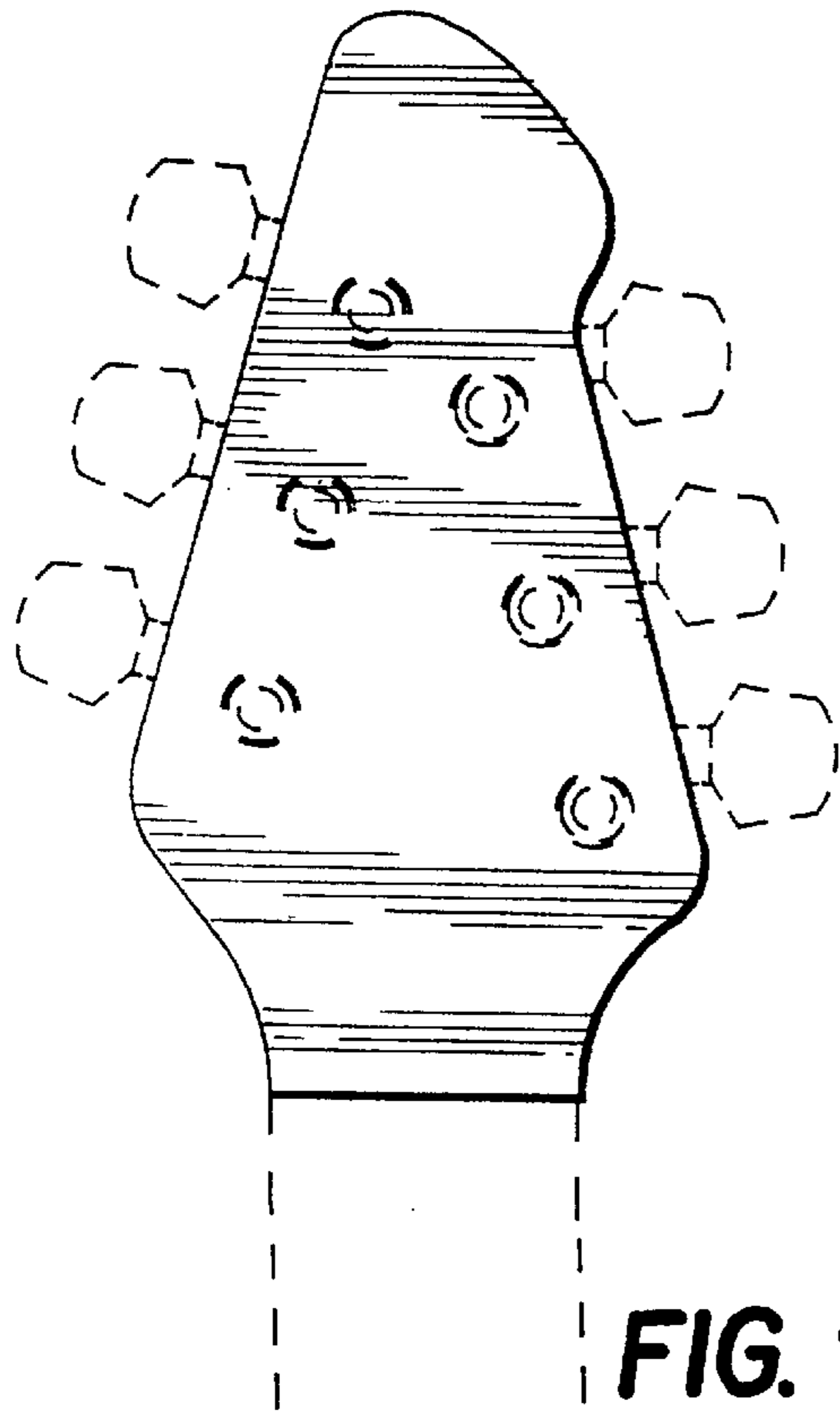

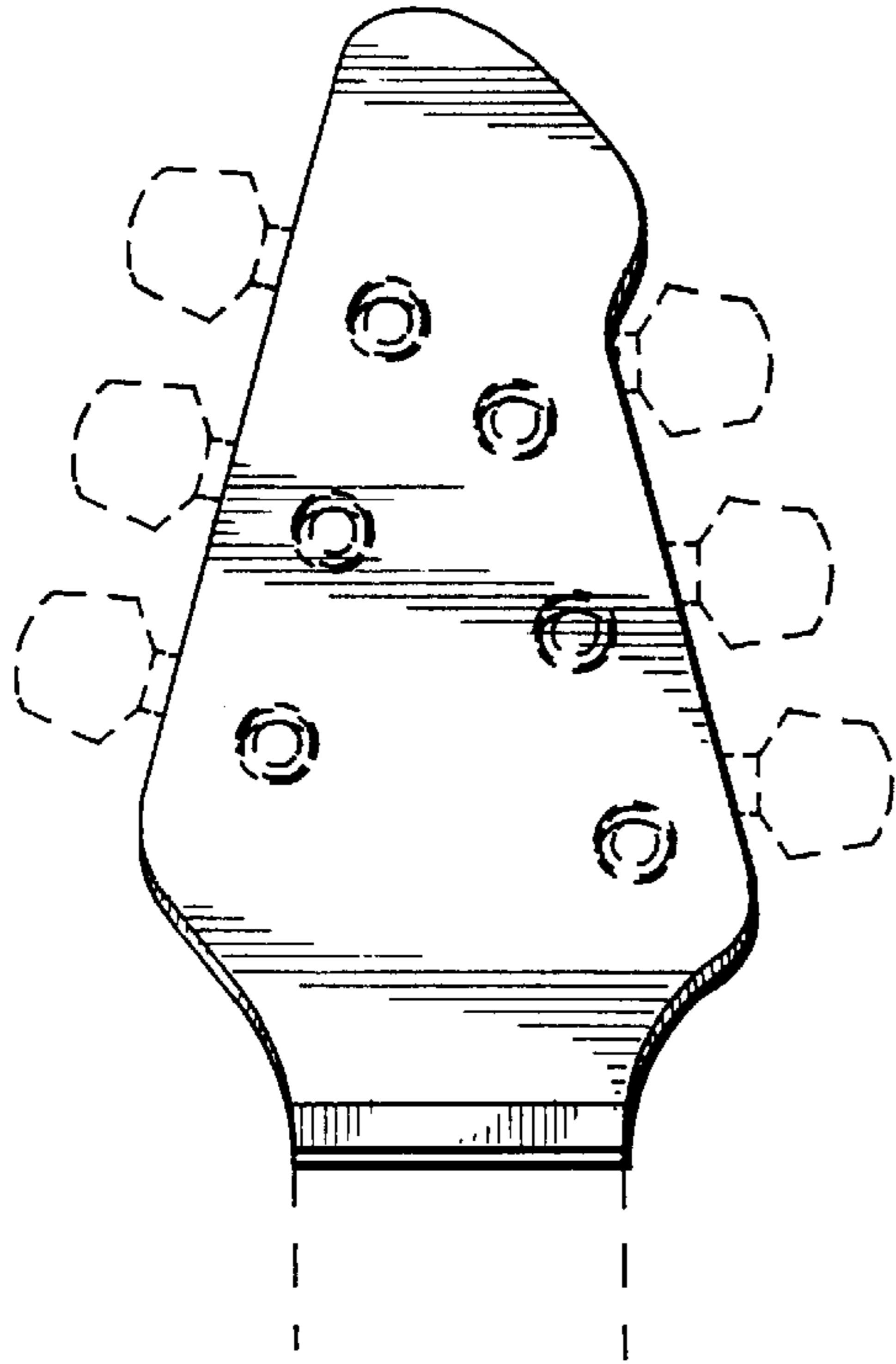

FIG. 7

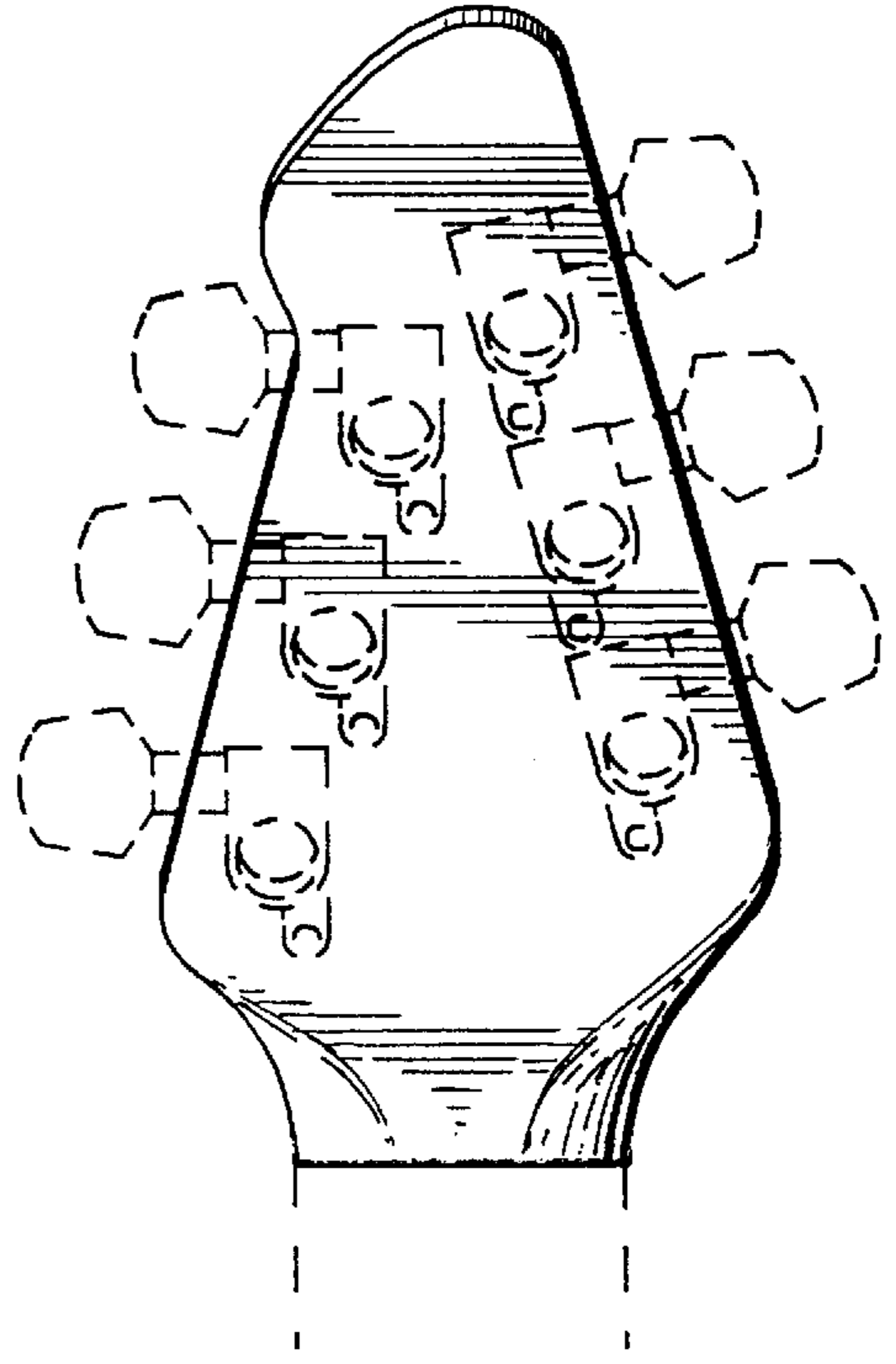

FIG. 8

FIG. 9

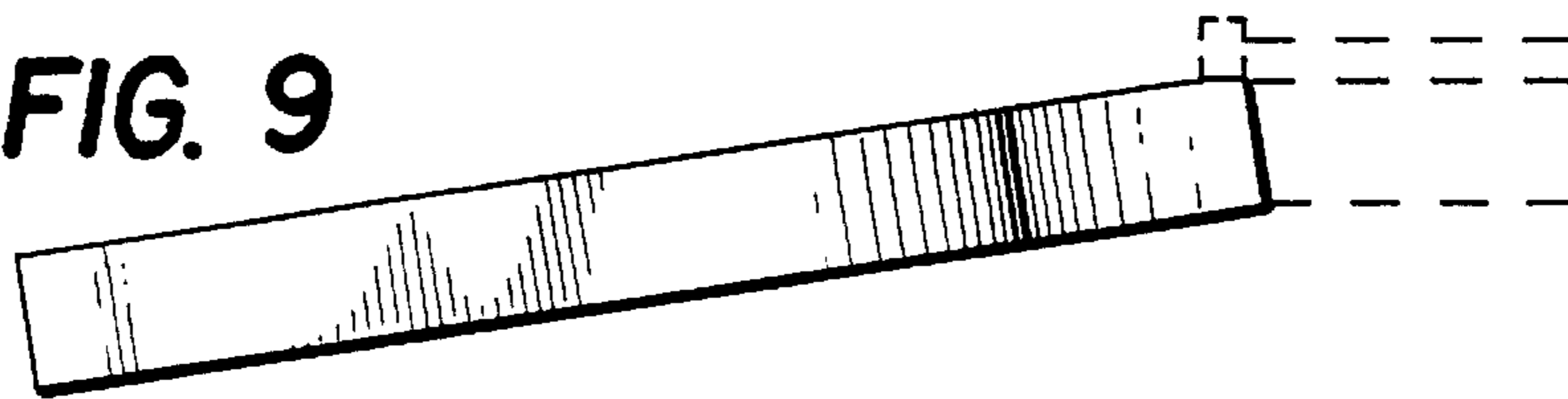

FIG. 10

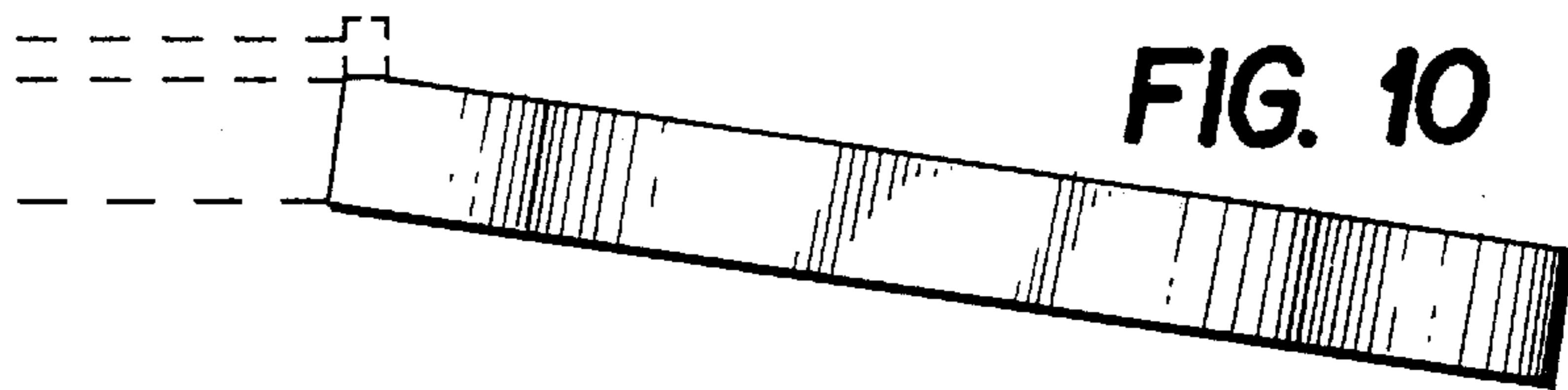

FIG. 11

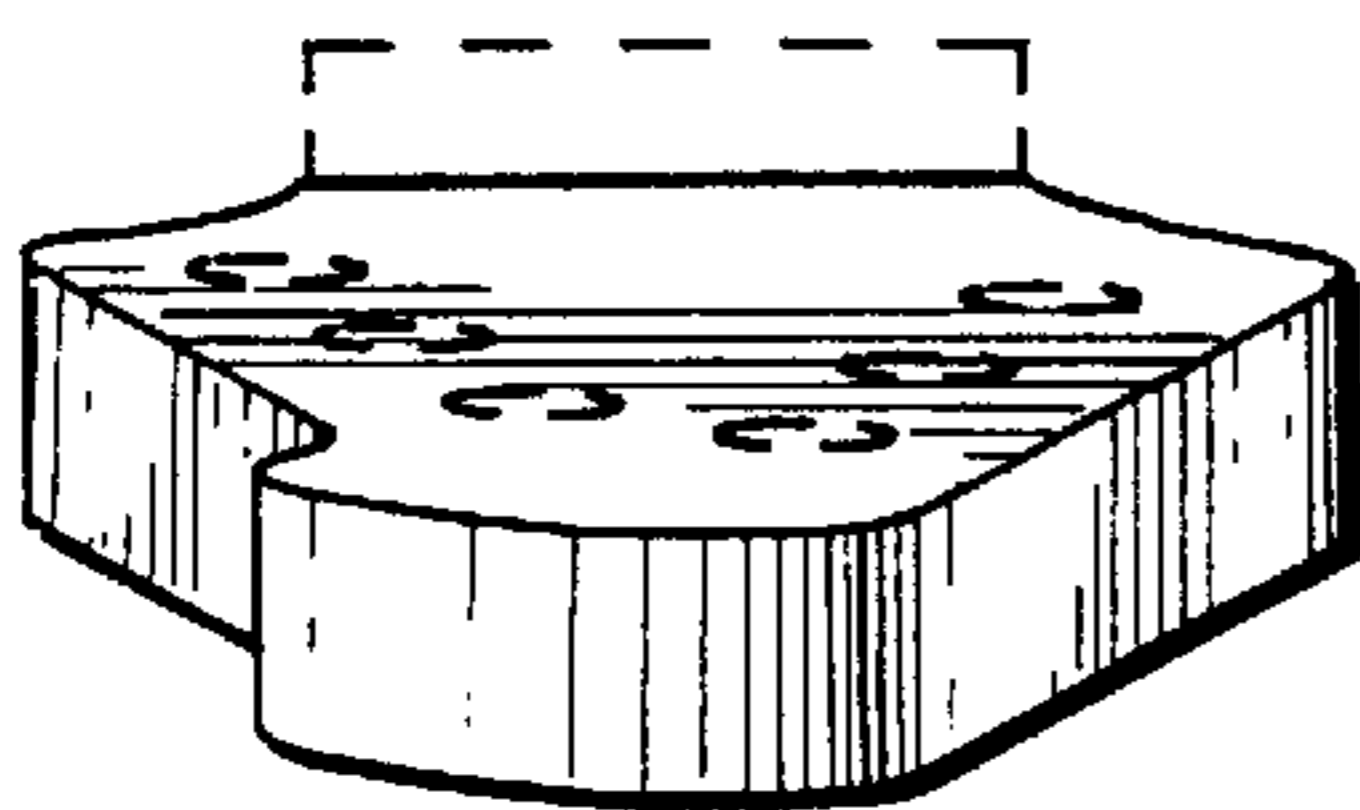

FIG. 12

