



US00D416854S

United States Patent [19] Huh

[11] **Patent Number: Des. 416,854**

[45] **Date of Patent: ** Nov. 23, 1999**

[54] **COVERING FOR WINDOWS IN AN AUTOMOBILE**

5,562,142 10/1996 Ziel et al. 160/370.21
5,615,923 4/1997 Madison 296/95.1

[76] Inventor: **Hyo-Kil Huh**, Dongah Apt. 305,
#393-3, Yongho 3-dong, Nam-gu,
Pusan, Rep. of Korea, 608-093

Primary Examiner—Doris V. Coles
Assistant Examiner—Stacia Sinuik
Attorney, Agent, or Firm—Anderson Kill & Olick

[**] Term: **14 Years**

[57] **CLAIM**

[21] Appl. No.: **29/083,722**

The ornamental design for a covering for windows in an automobile, as shown and described.

[22] Filed: **Feb. 17, 1998**

DESCRIPTION

[51] **LOC (6) Cl.** **12-16**

[52] **U.S. Cl.** **D12/401**

[58] **Field of Search** D12/401, 190-191;
280/770, 847, 848; 296/97.1-97.3, 97.6-97.9,
96.11, 95.1, 96; 160/370.21, 370.22, 370.23,
DIG. 3

FIG. 1 is a perspective view of a covering for windows in an automobile showing my new design;
FIG. 2 is an enlarged top plan view thereof;
FIG. 3 is an enlarged bottom plan view thereof;
FIG. 4 is an enlarged front elevational view thereof;
FIG. 5 is an enlarged rear elevational view thereof;
FIG. 6 is an enlarged left side elevational view thereof;
FIG. 7 is an enlarged right side elevational view thereof;
FIG. 8 is an enlarged fragmentary view of one end of the covering shown in FIG. 1;
FIG. 9 is an enlarged fragmentary view of the other end of the covering shown in FIG. 1; and,
FIG. 10 is a reduced perspective view of the covering for windows in an automobile, shown in its position of use.
The broken line showing of environment in FIG. 10 is for illustrative purposes only and forms no part of the claimed design.

[56] **References Cited**

U.S. PATENT DOCUMENTS

Re. 35,080	11/1995	Nenstiel	160/370.21
D. 356,286	3/1995	Shink	D12/191
D. 356,540	3/1995	Hammontree	D12/401
D. 367,029	2/1996	Spaulding	D12/191
D. 369,997	5/1996	Ruimi	D12/190
D. 369,998	5/1996	Eskandry	D12/191
D. 370,449	6/1996	Wang	D12/191
D. 370,650	6/1996	Eskandry	D12/191
D. 375,928	11/1996	Wang	D12/191
5,356,191	10/1994	Sheehan	296/95.1

1 Claim, 5 Drawing Sheets

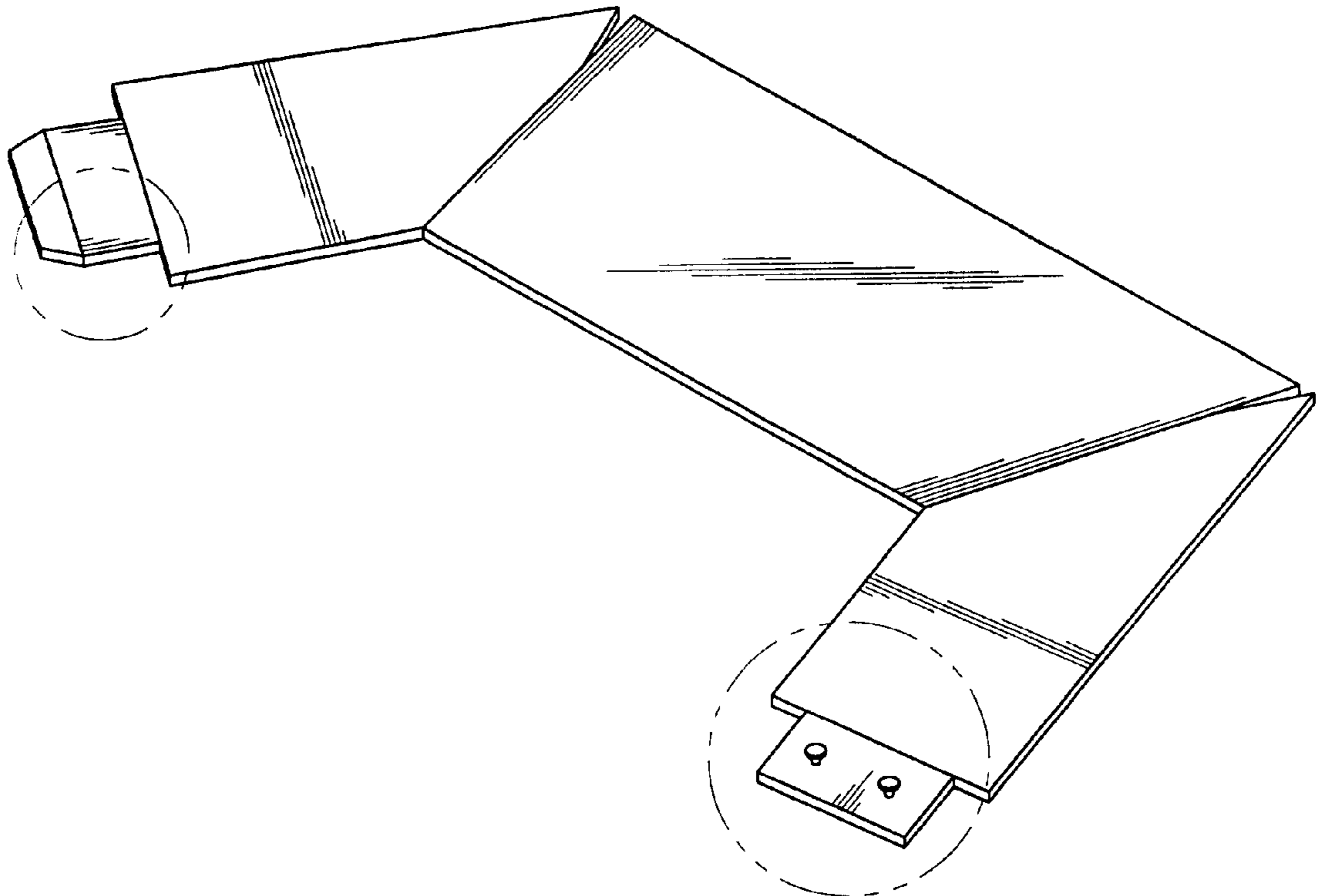

FIG. 1

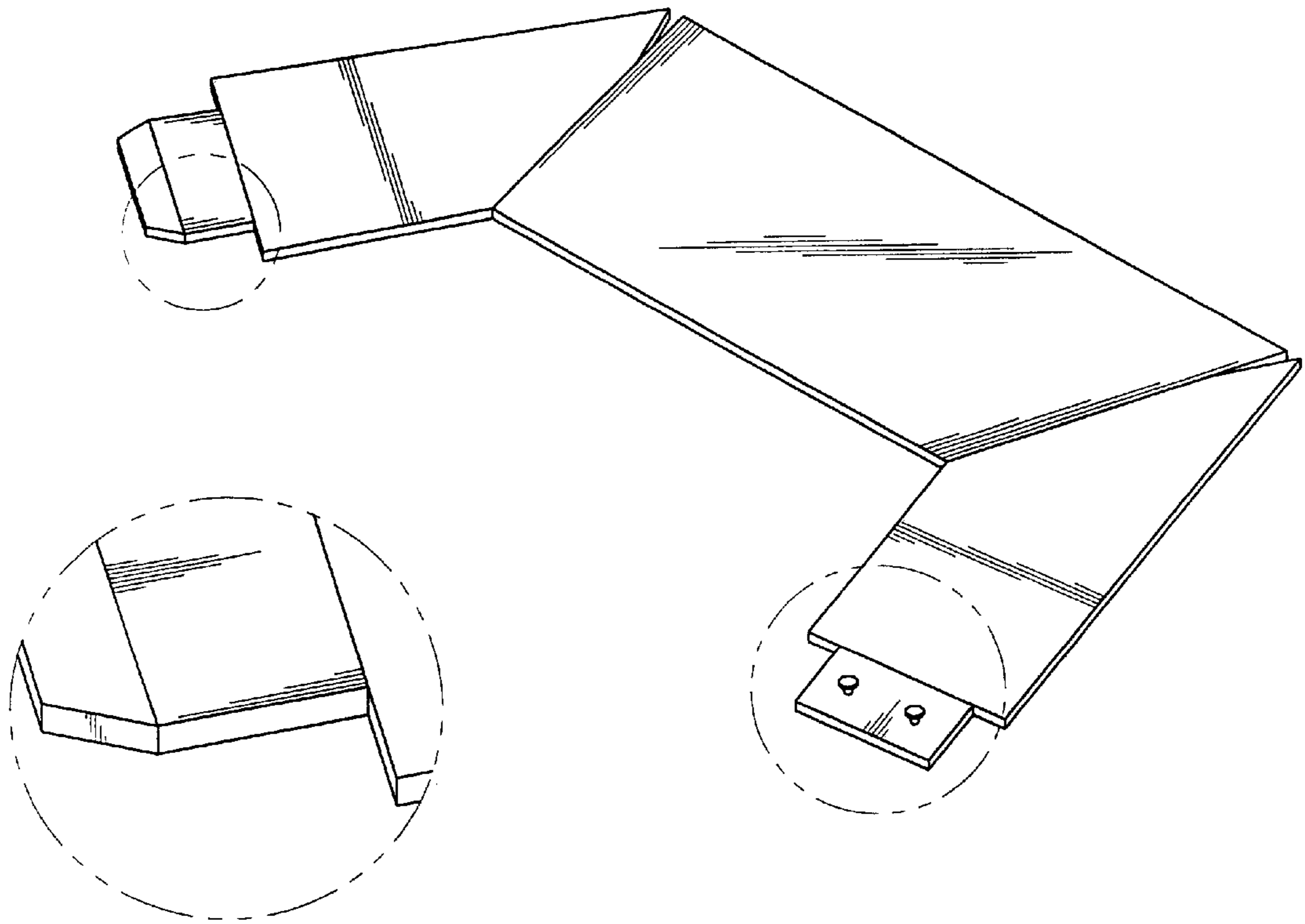

FIG. 8

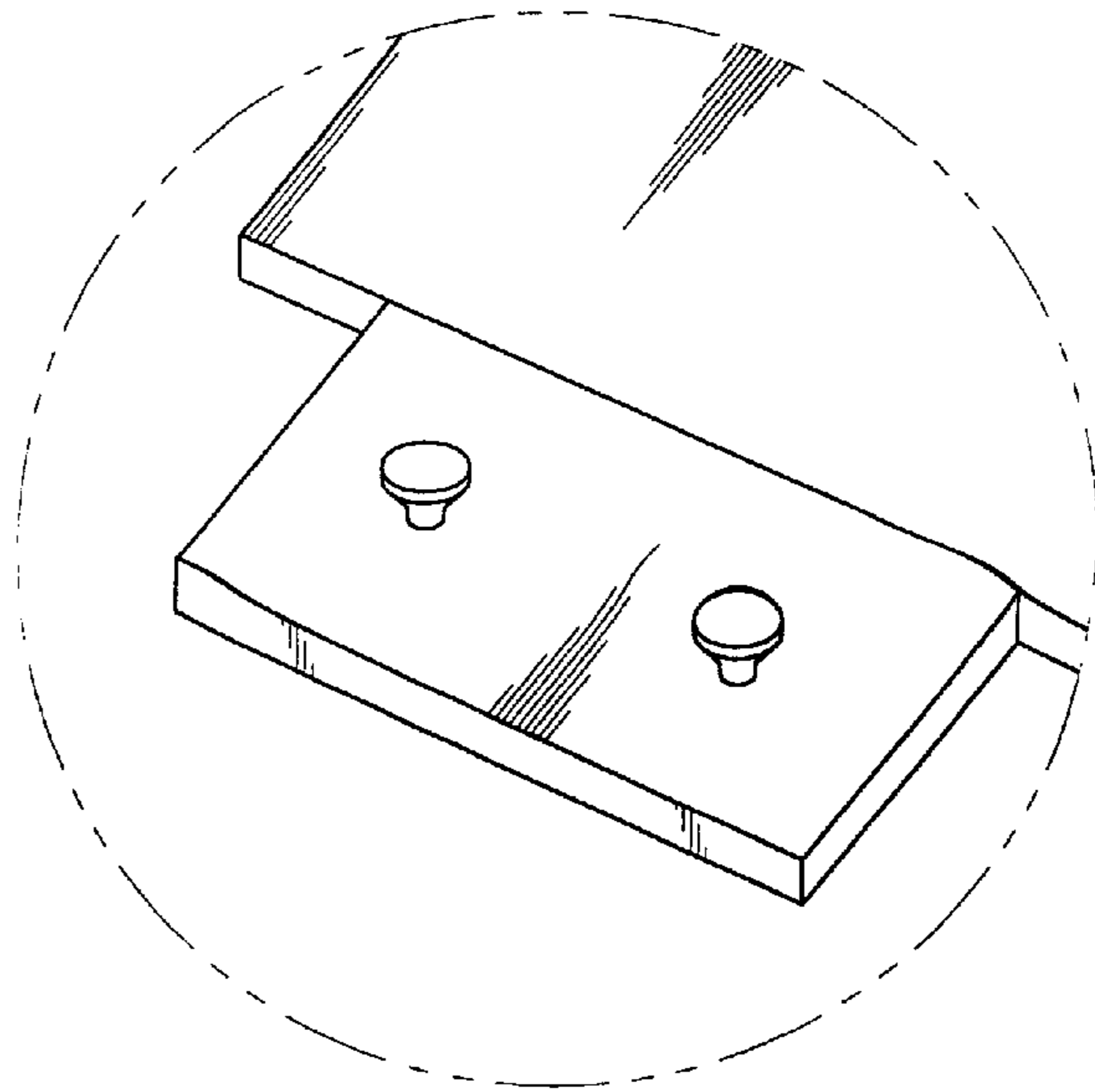

FIG. 9

FIG. 2

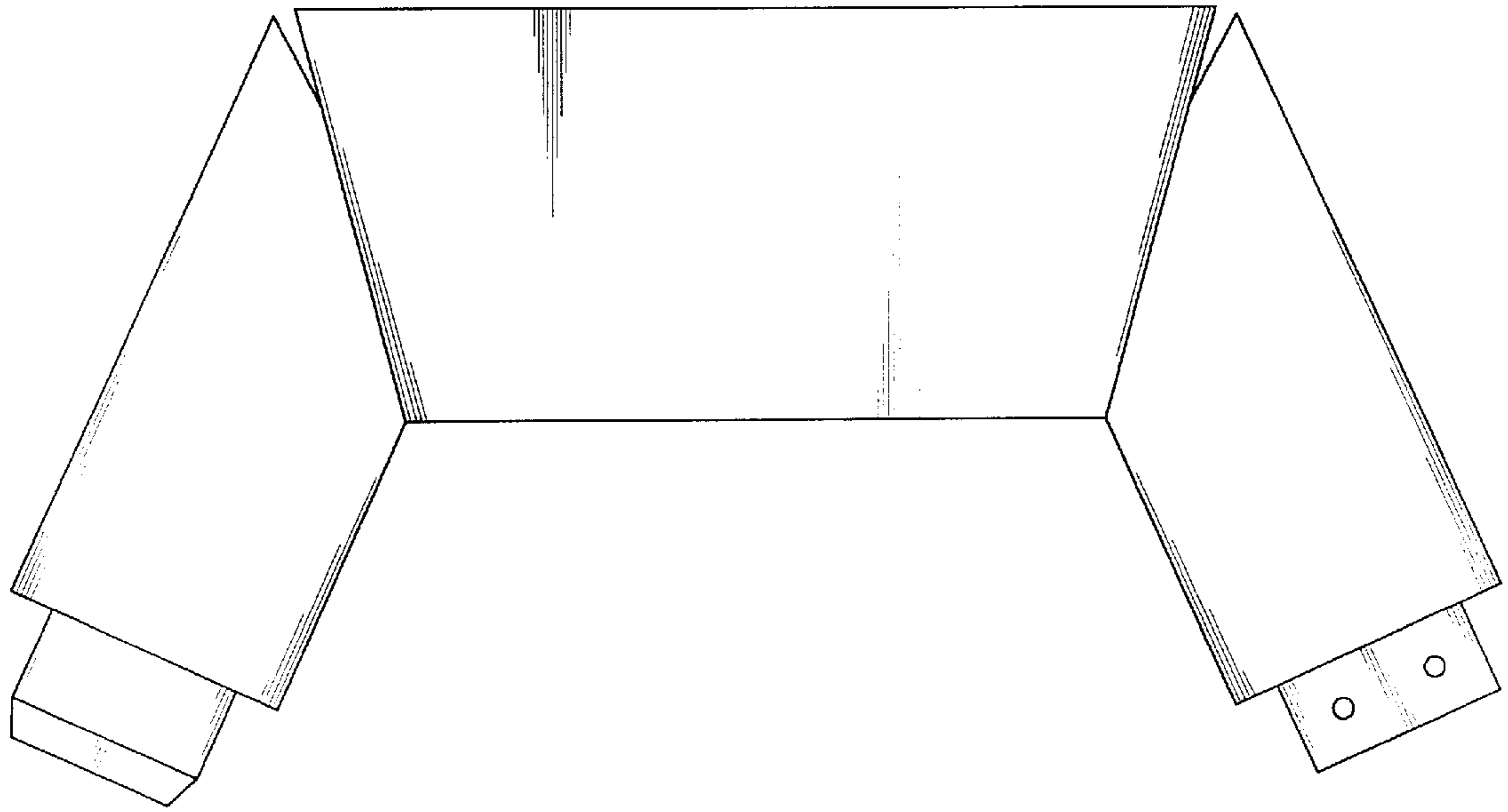

FIG. 3

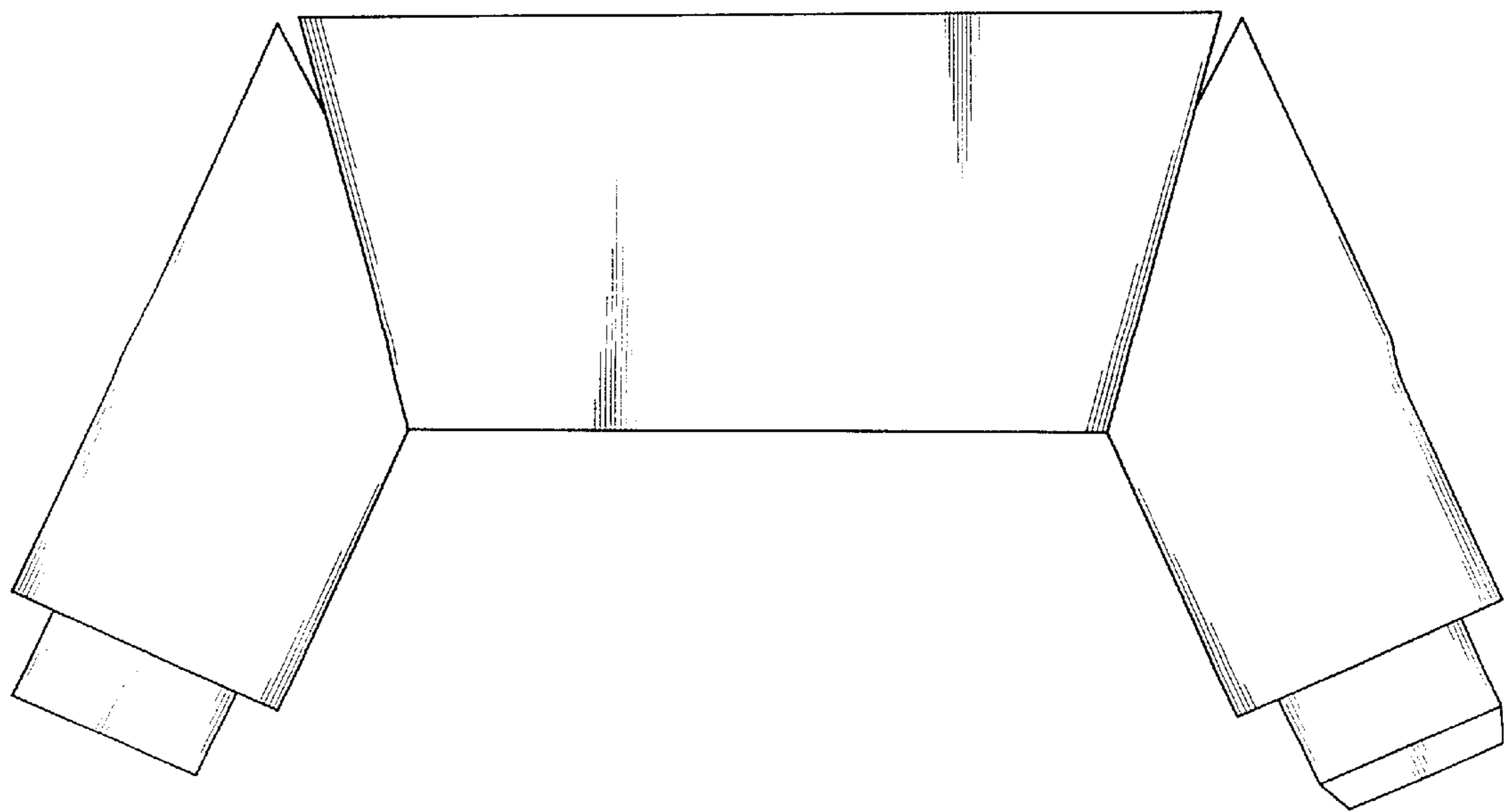

FIG. 4

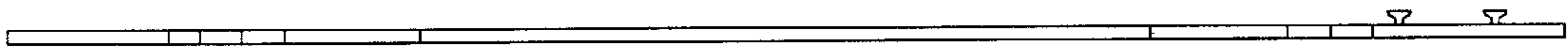

FIG. 5

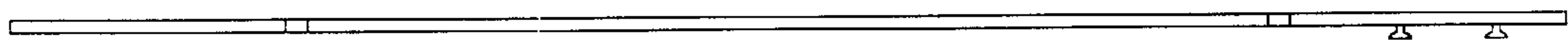

FIG. 6

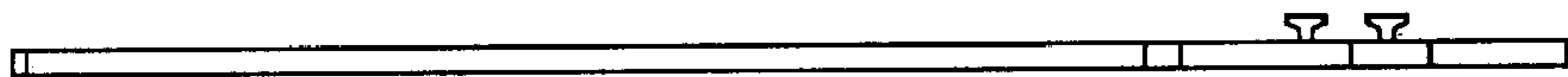

FIG. 7

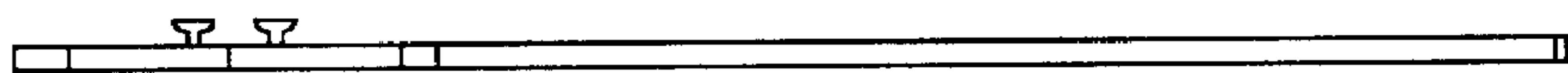

FIG. 10

