



US00D416846S

United States Patent [19]

Melegari et al.

[11] Patent Number: **Des. 416,846**

[45] Date of Patent: **** Nov. 23, 1999**

[54] **FRONT FACE OF A VEHICLE WHEEL**

[75] Inventors: **Gianfranco Melegari**, Castelleone;
Emanuele Roncadori, Manerbio;
Guglielmo Bertolinelli, Castiglione
d/Stiv.; **Gualtiero Cervati**, Brescia;
Claudio Galeazzi, Carpenezolo, all of
Italy

[73] Assignee: **Just Wheels & Tires**, Santa Ana, Calif.

[**] Term: **14 Years**

[21] Appl. No.: **29/095,789**

[22] Filed: **Oct. 30, 1998**

[51] **LOC (6) Cl.** **12-16**

[52] **U.S. Cl.** **D12/209**

[58] **Field of Search** D12/204-213;
301/64.1, 65, 37.1

[56] **References Cited**

U.S. PATENT DOCUMENTS

- D. 361,975 9/1995 Weld D12/210
- D. 367,030 2/1996 Bouldoukian D12/209

- D. 371,533 7/1996 Castiglione D12/209
- D. 372,698 8/1996 Mantua D12/209
- D. 389,112 1/1998 Chung D12/209
- D. 403,649 1/1999 Moreno D12/211
- D. 407,363 3/1999 Muzzarelli D12/209
- D. 408,345 4/1999 Cullen D12/209

Primary Examiner—Doris V. Coles
Assistant Examiner—Stacia Sinuik
Attorney, Agent, or Firm—Liniak, Berenato, Longacre &
White

[57] **CLAIM**

The ornamental design for a front face of a vehicle wheel,
as shown and described.

DESCRIPTION

FIG. 1 is a front elevational view of the front face of a
vehicle according to the invention; and,
FIG. 2 is a perspective view of the front face of a vehicle
wheel as shown in FIG. 1.

The broken line showing the rear portion of the vehicle
wheel in FIG. 2 is for illustrative purposes and forms no part
of the claimed design.

1 Claim, 2 Drawing Sheets

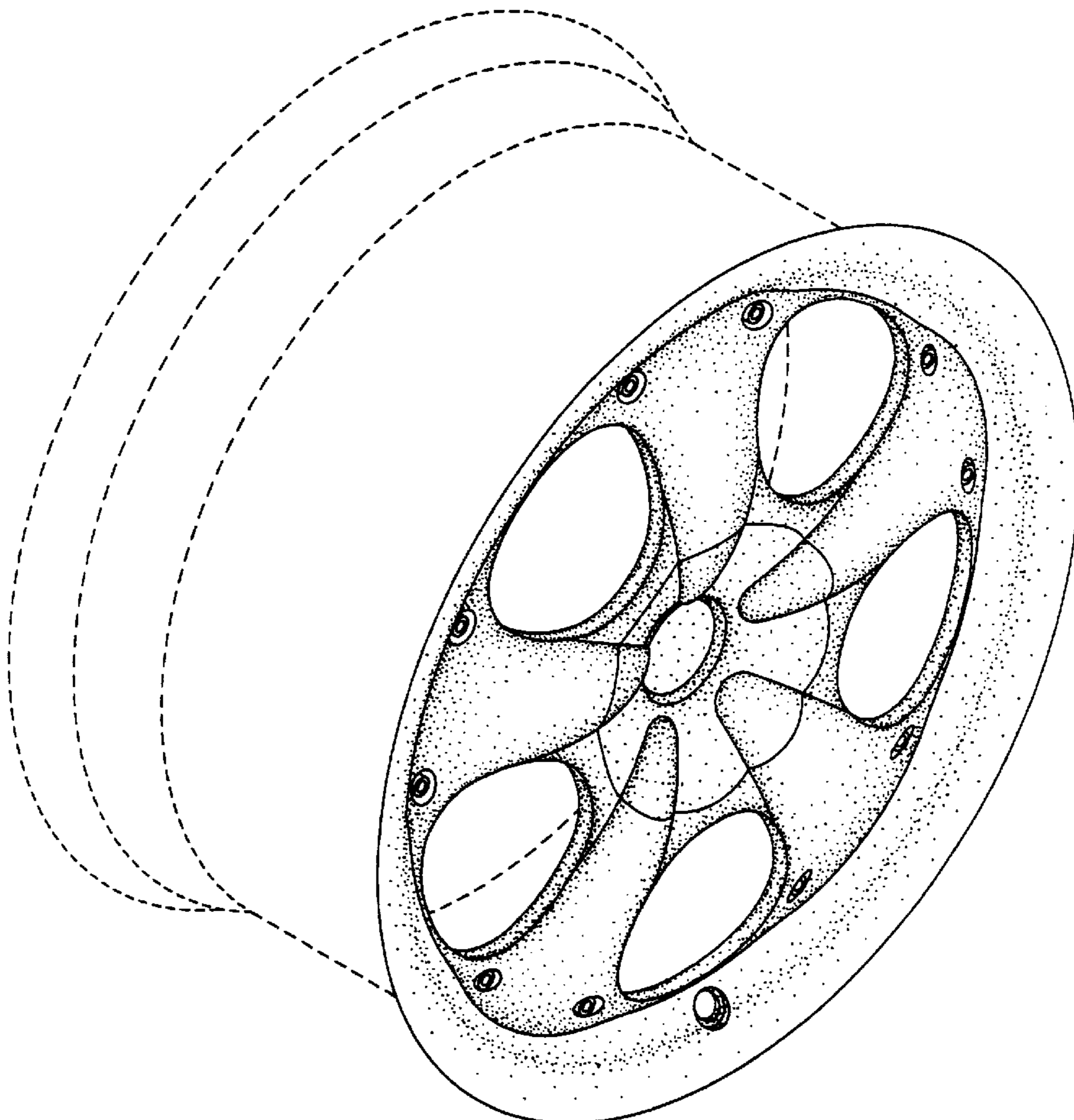

Fig. 1

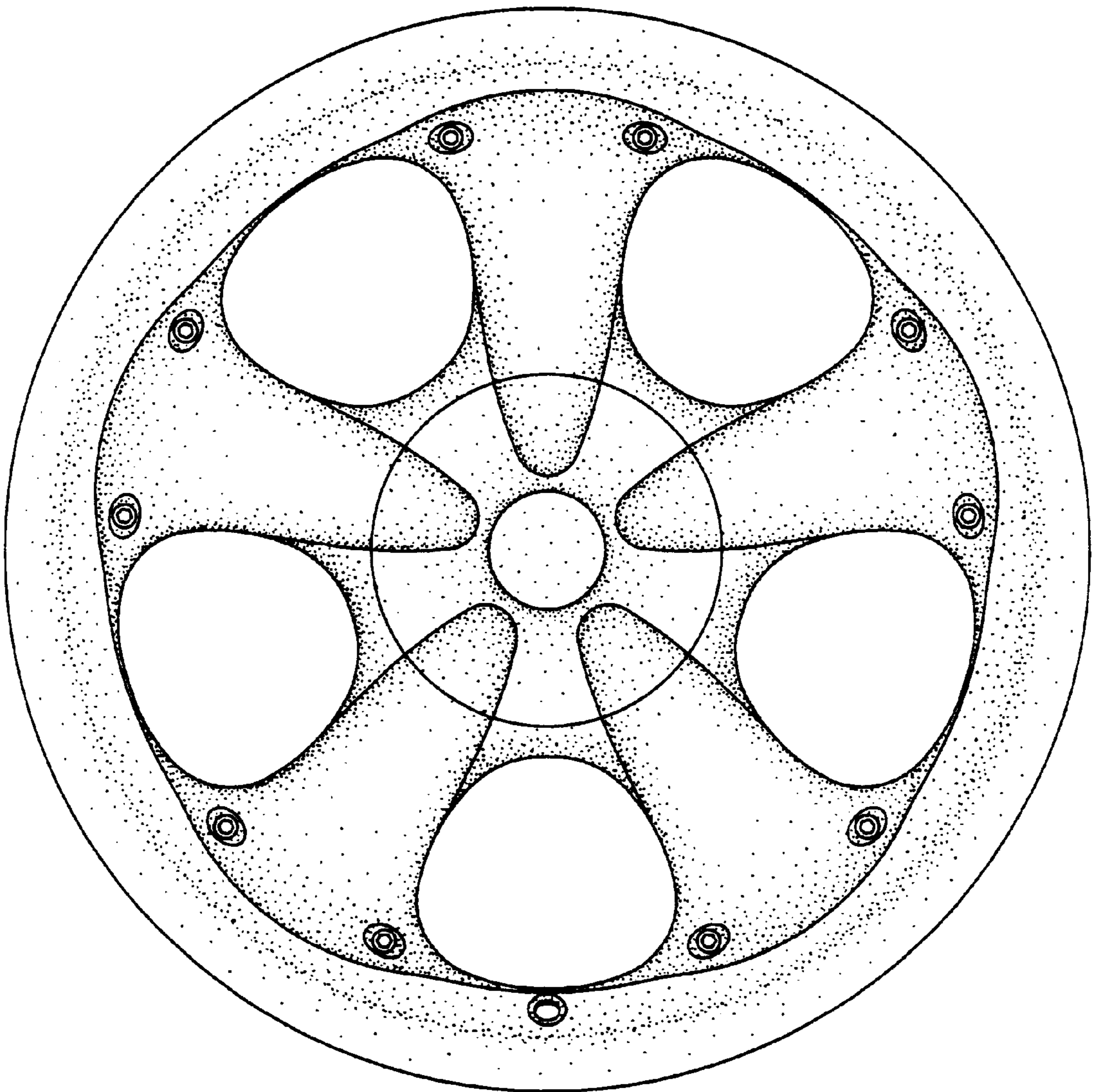

Fig. 2

