



US00D416369S

United States Patent [19] Johansson

[11] **Patent Number: Des. 416,369**

[45] **Date of Patent: ** Nov. 9, 1999**

[54] **FORKLIFT TROLLEY**

[76] Inventor: **Rutger Johansson**, Smedgatan 20,
SE-662 00 Åmål, Sweden

[**] Term: **14 Years**

[21] Appl. No.: **29/089,287**

[22] Filed: **Jun. 11, 1998**

[30] Foreign Application Priority Data

Apr. 20, 1998 [SE] Sweden 98 0862

[51] **LOC (6) Cl.** **12-05**

[52] **U.S. Cl.** **D34/28; D34/31; D34/34**

[58] **Field of Search** **D34/28, 34; 280/43.12, 280/43.23; 180/19.1, 19.2, 19.3**

[56] References Cited

U.S. PATENT DOCUMENTS

D. 346,680 5/1994 Lee D34/31
D. 401,716 11/1998 Marcel D34/34
3,026,089 3/1962 Meister 280/43.12

3,261,617 7/1966 Becker et al. 280/43.12
3,286,985 11/1966 Edera 280/43.23
4,589,669 5/1986 Kedem 280/43.12
4,669,561 6/1987 Sheen 180/19.1

Primary Examiner—Susan J. Lucas
Assistant Examiner—Cynthia E Ramirez
Attorney, Agent, or Firm—Dvorak & Orum

[57] CLAIM

The ornamental design for the forklift trolley, as shown and described.

DESCRIPTION

FIG. 1 is a perspective view of the forklift trolley;
FIG. 2 is a left side elevational view;
FIG. 3 is a top plan view;
FIG. 4 is a bottom plan view;
FIG. 5 is a right side elevational view;
FIG. 6 is a front elevational view;
FIG. 7 is a rear elevational view; and,
FIG. 8 is a side elevational view showing the forklift trolley, in an elevation position.

1 Claim, 5 Drawing Sheets

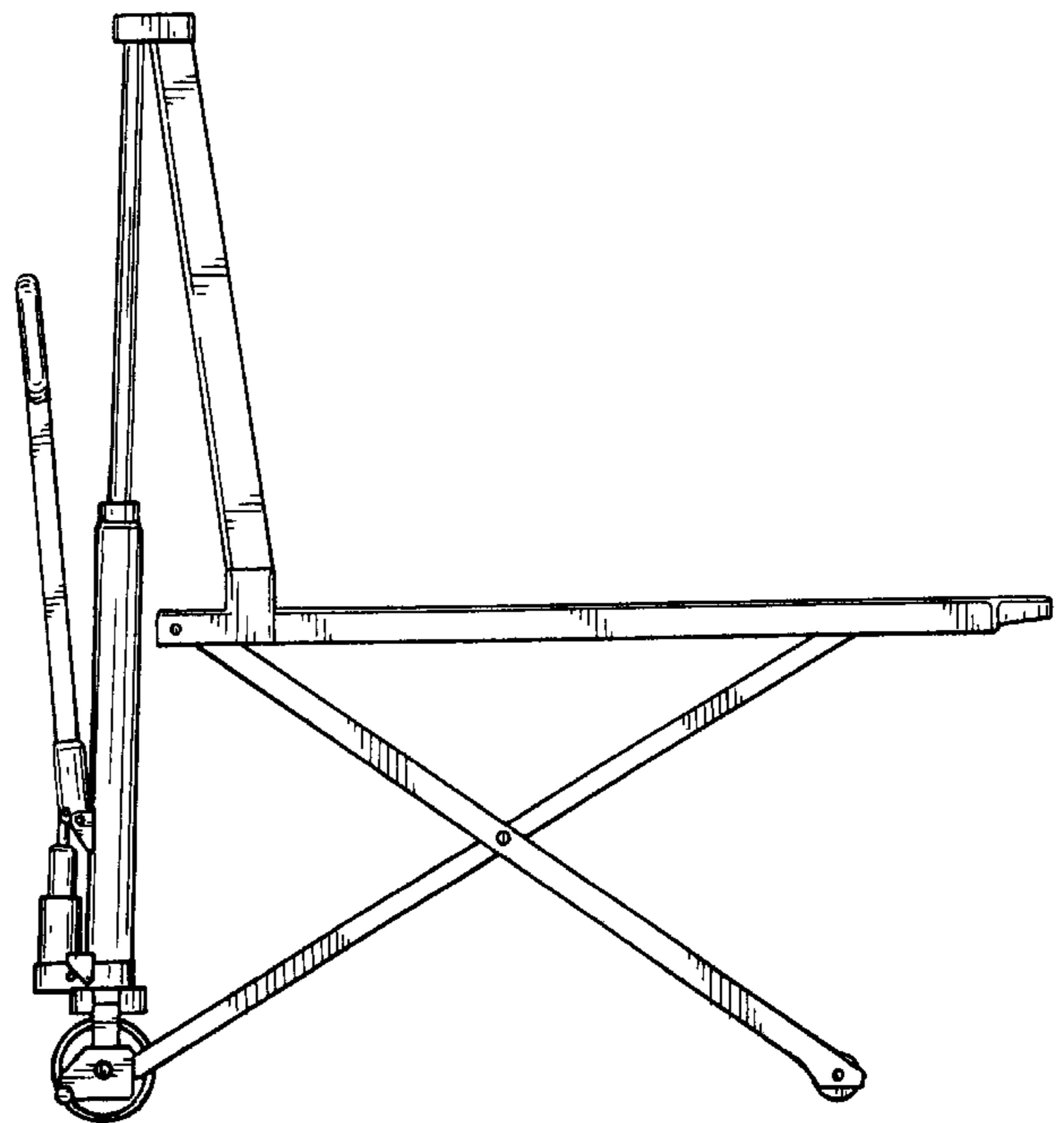
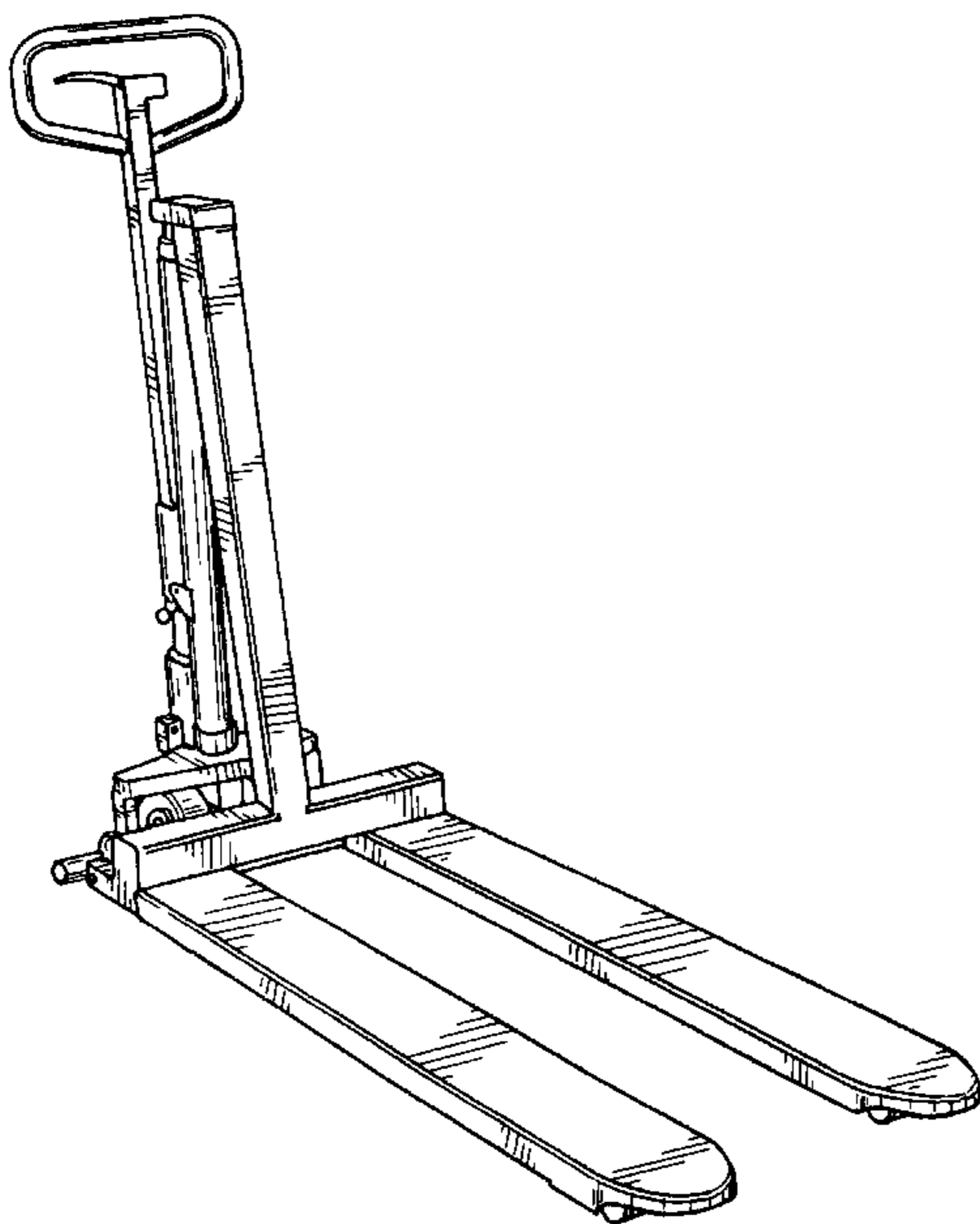

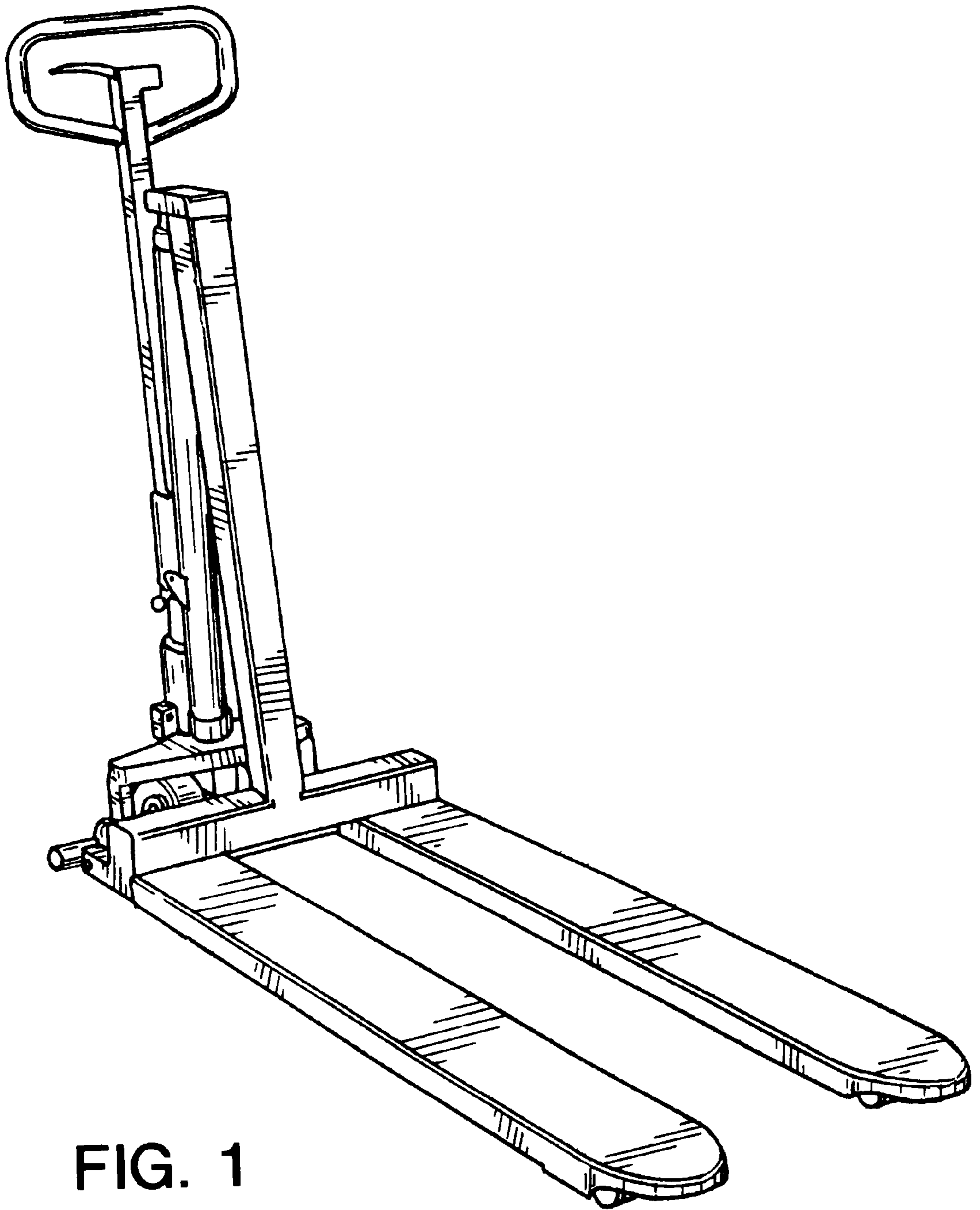

FIG. 1

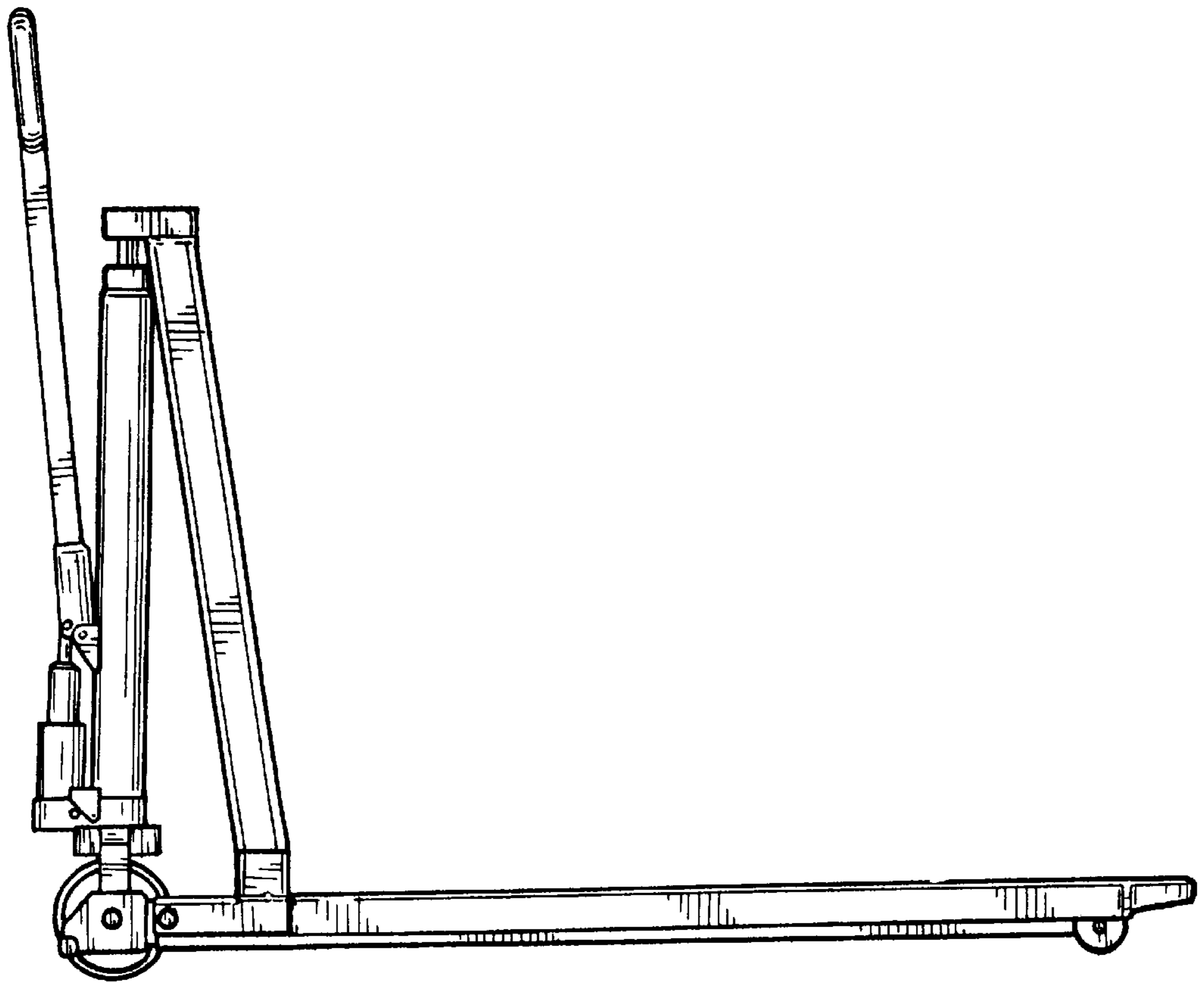

FIG. 2

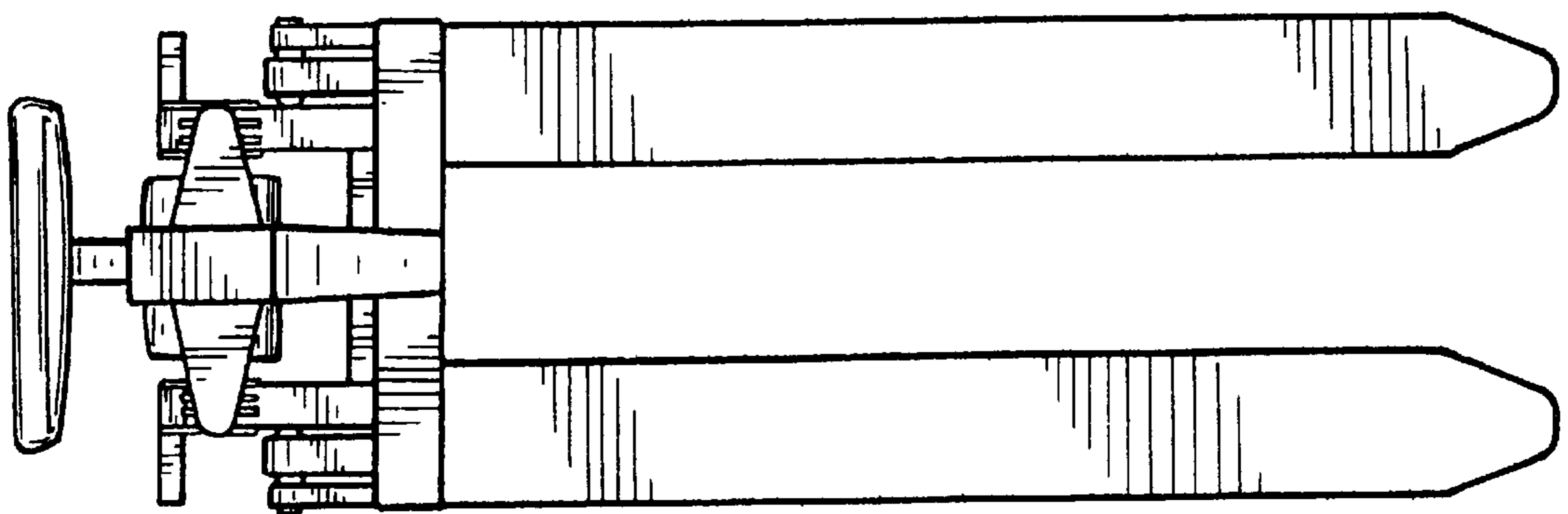

FIG. 3

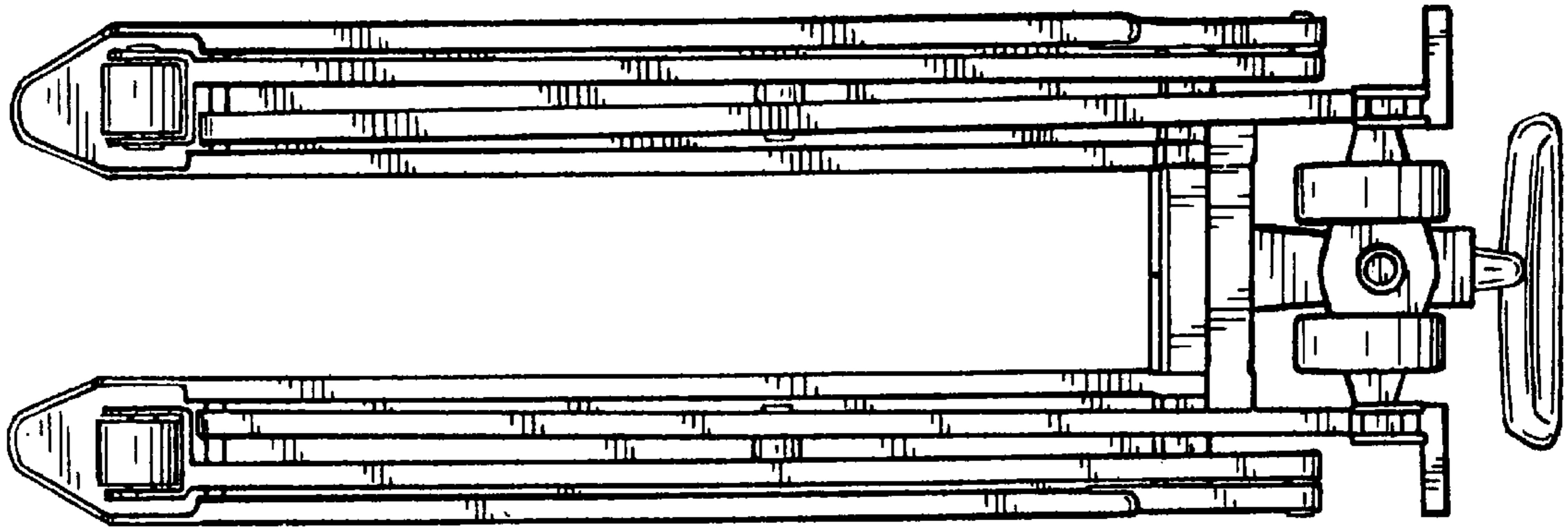

FIG. 4

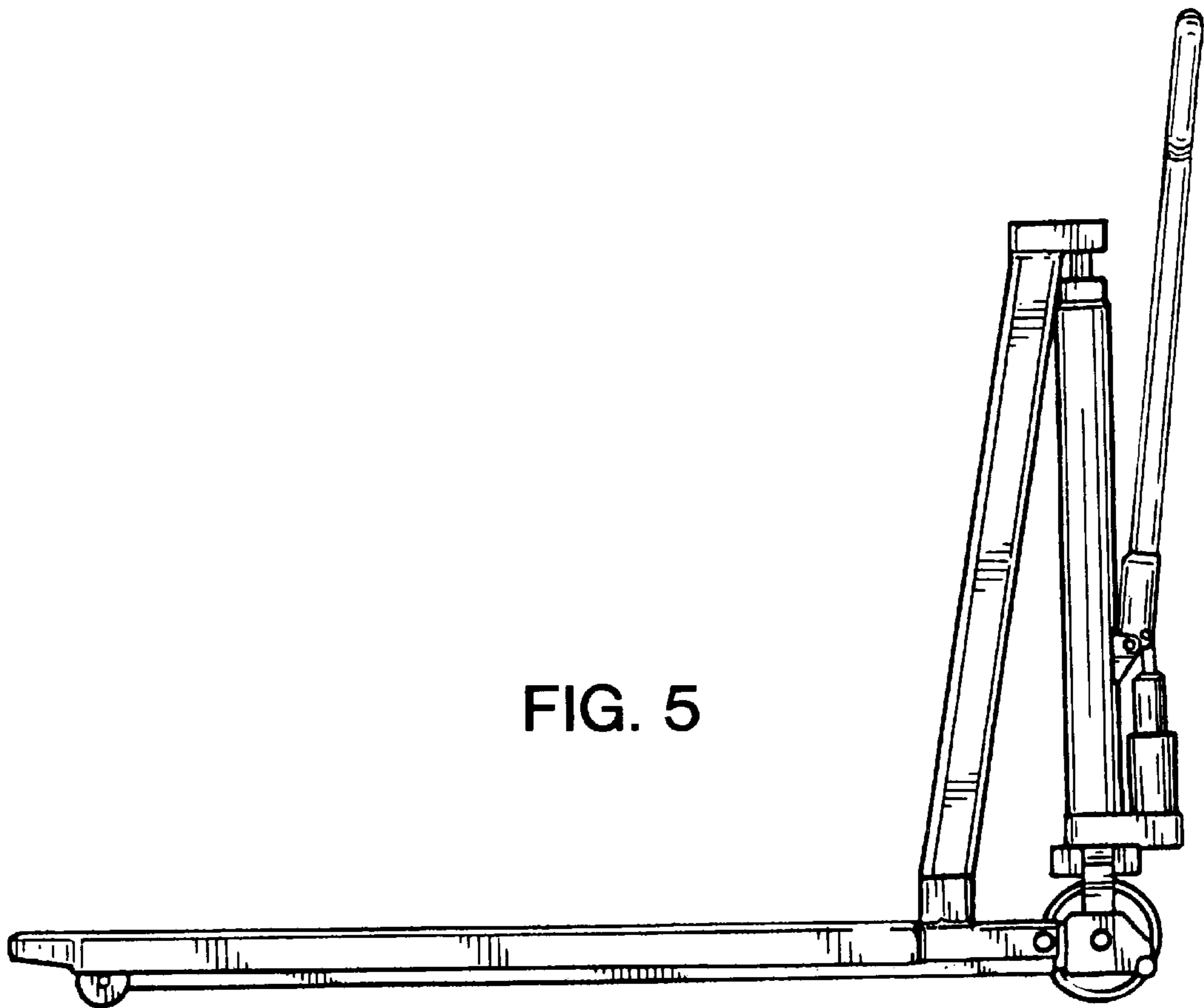

FIG. 5

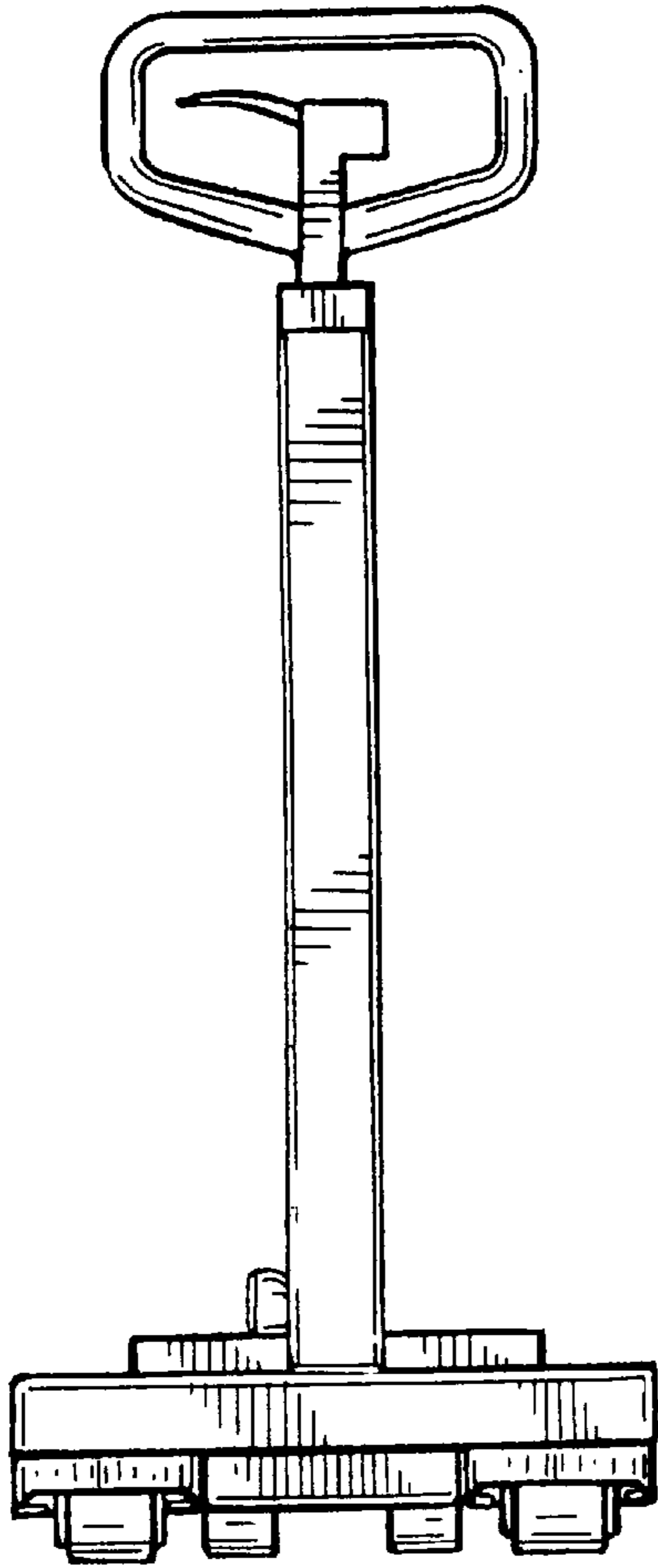

FIG. 6

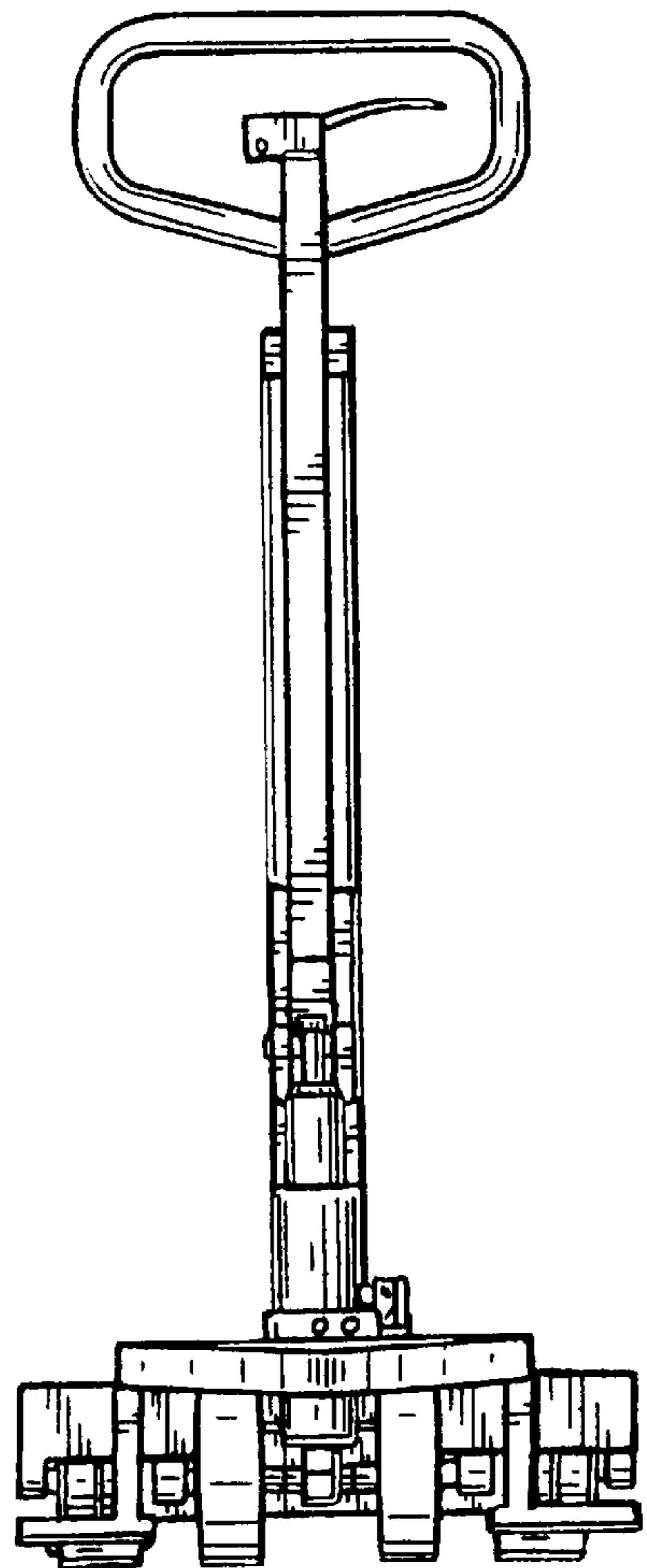

FIG. 7

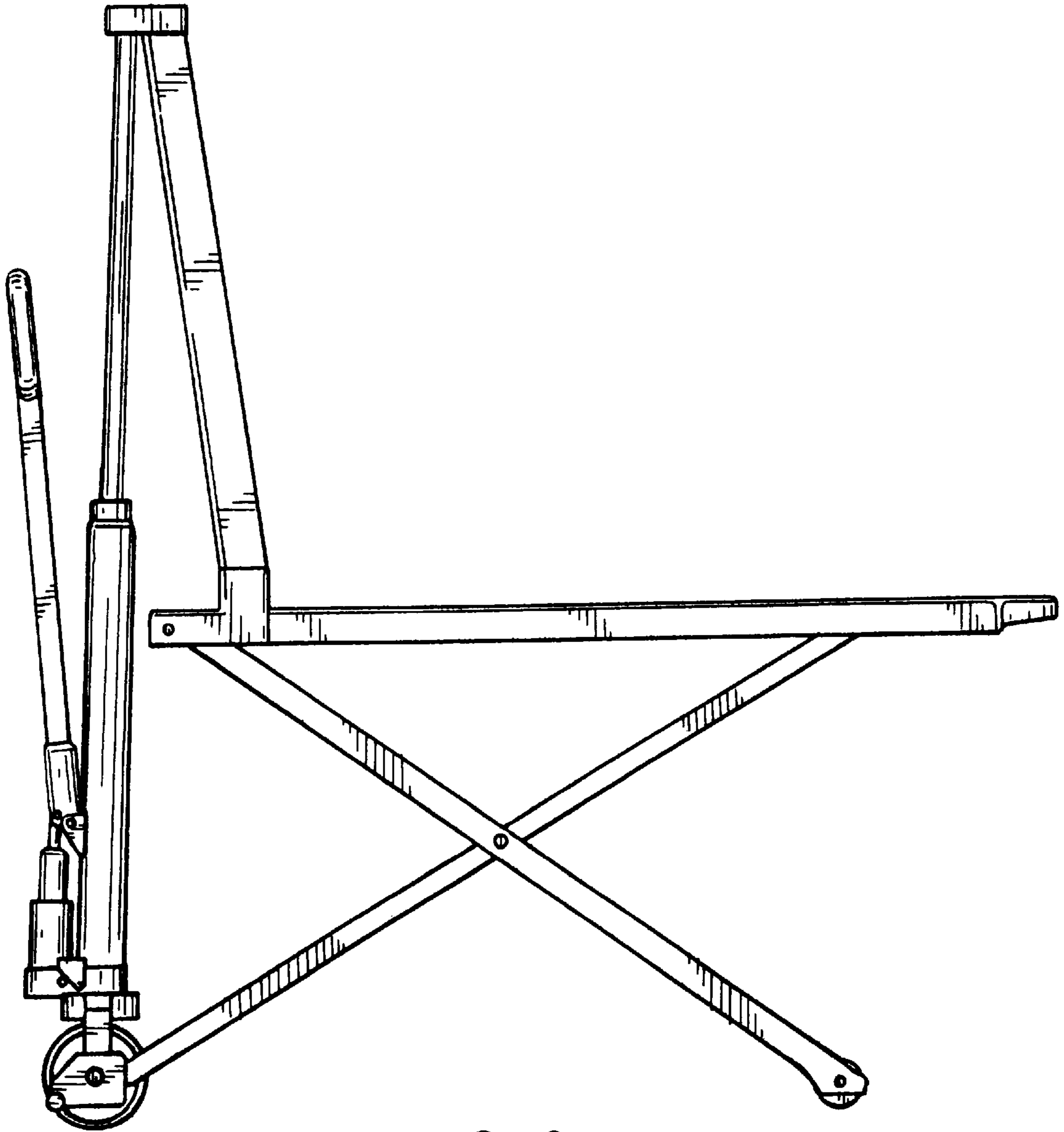

FIG. 8