



US00D416331S

United States Patent [19] Rom

[11] Patent Number: Des. 416,331

[45] Date of Patent: ** Nov. 9, 1999

[54] COLUMN SURROUND SIMULATING A STACK OF GAMING CHIPS

[76] Inventor: Jeffery A. Rom, 2218 Adriatic, Henderson, Nev. 89014

[**] Term: 14 Years

[21] Appl. No.: 29/078,345

[22] Filed: Oct. 22, 1997

[51] LOC (6) Cl. 25-02

[52] U.S. Cl. D25/38; D20/41; D25/130

[58] Field of Search D20/10, 19, 41; D25/126, 130, 38; 40/584, 606, 607, 608; 256/1, 19, 21, 22, 34, 59, 65, 66

[56] References Cited

U.S. PATENT DOCUMENTS

D. 90,909	10/1933	Downey	D25/130
D. 334,215	3/1993	Rowlands	D20/41
D. 349,164	7/1994	Fox	D25/38
4,209,928	7/1980	Kraayvanger	40/607
4,516,756	5/1985	Beatty	256/1

Primary Examiner—Doris Clark
Attorney, Agent, or Firm—Quirk & Tratos

[57] CLAIM

The ornamental design for a column surround simulating a stack of gaming chips, as shown and described.

DESCRIPTION

FIG. 1 is a top perspective view of the column surround simulating a stack of gaming chips of the present invention adapted to be disposed about a column such as a concrete building column;

FIG. 2 is a front view of one embodiment of the column surround simulating a stack of gaming chips;

FIG. 3 is a right side view of the column surround simulating a stack of gaming chips of FIG. 1;

FIG. 4 is a rear view of the column surround simulating a stack of gaming chips of FIG. 1;

FIG. 5 is a left side view of the column surround simulating a stack of gaming chips of FIG. 1;

FIG. 6 is a top view of the column surround simulating a stack of gaming chips of FIG. 1;

FIG. 7 is a bottom view of the column surround simulating a stack of gaming chips of FIG. 1;

FIG. 8 is a top perspective view of the surround of another embodiment of the present invention adapted to be disposed about a column such as a concrete building column;

FIG. 9 is a front view of the column surround simulating a stack of gaming chips of FIG. 8;

FIG. 10 is a right side view of the column surround simulating a stack of gaming chips of FIG. 8;

FIG. 11 is a rear view of the column surround simulating a stack of gaming chips of FIG. 8;

FIG. 12 is a left side view of the column surround simulating a stack of gaming chips of FIG. 8;

FIG. 13 is a top view of the column surround simulating a stack of gaming chips of FIG. 8; and,

FIG. 14 is a bottom view of the column surround simulating a stack of gaming chips of FIG. 8.

1 Claim, 8 Drawing Sheets

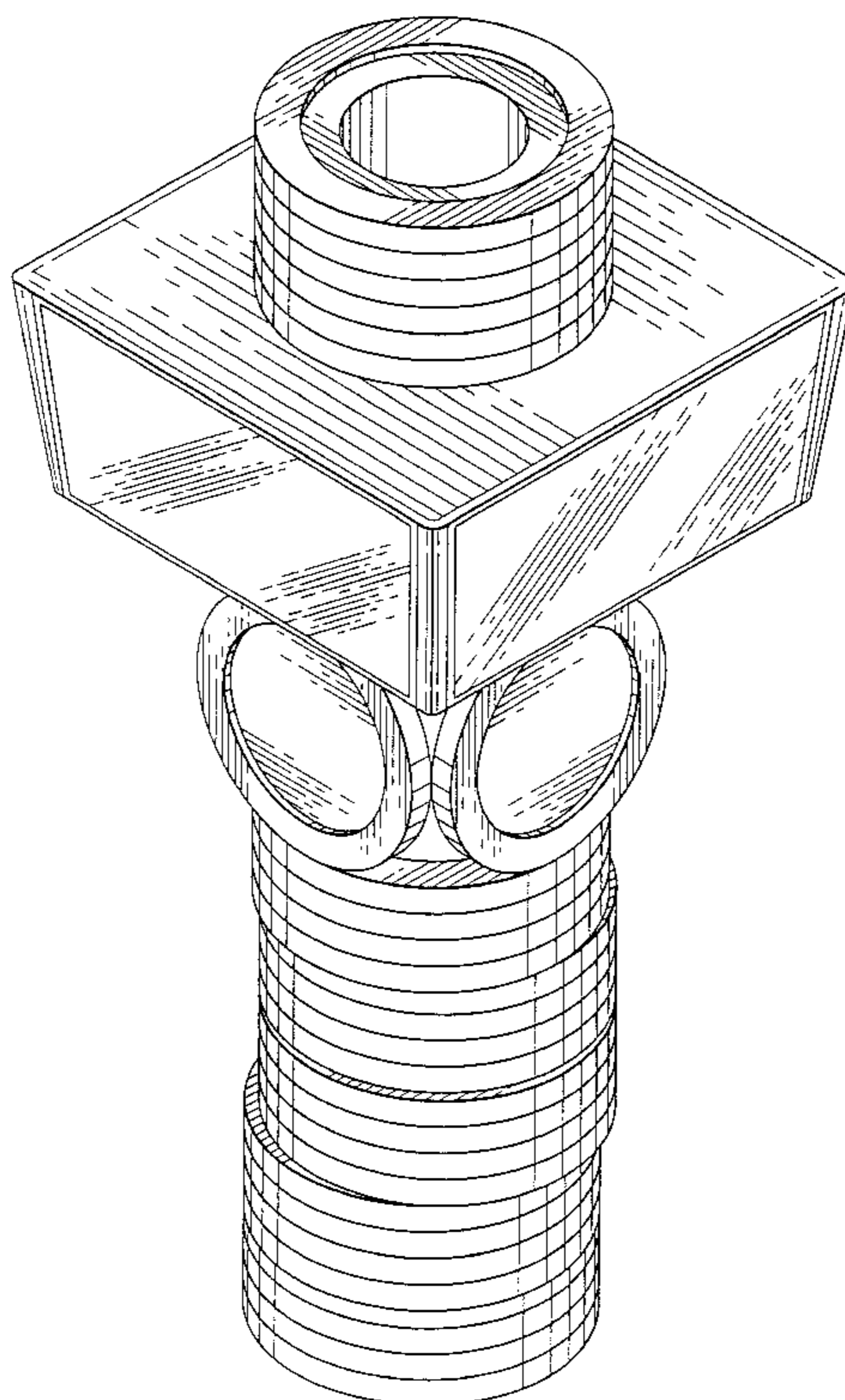

FIG. 1

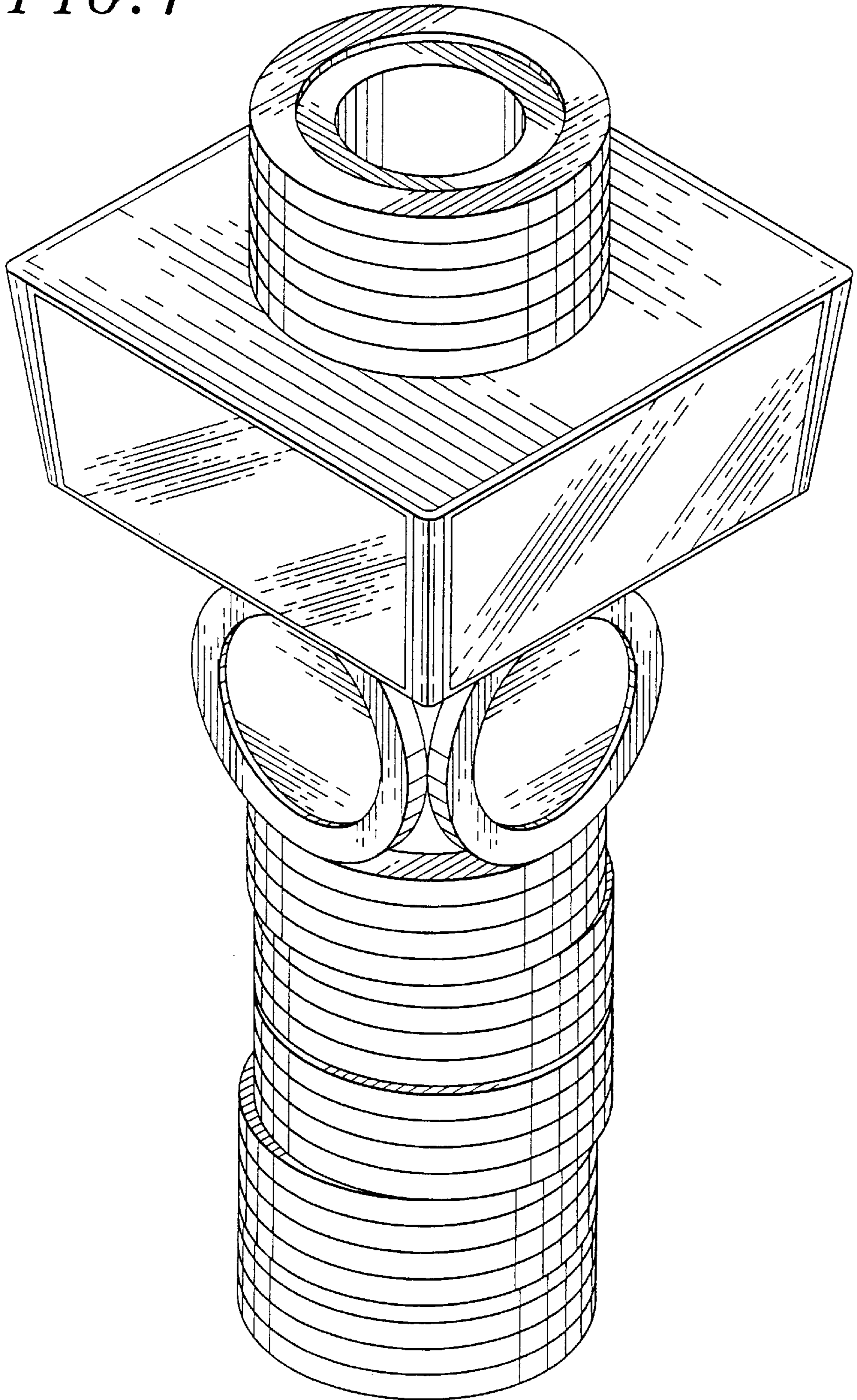

FIG. 2

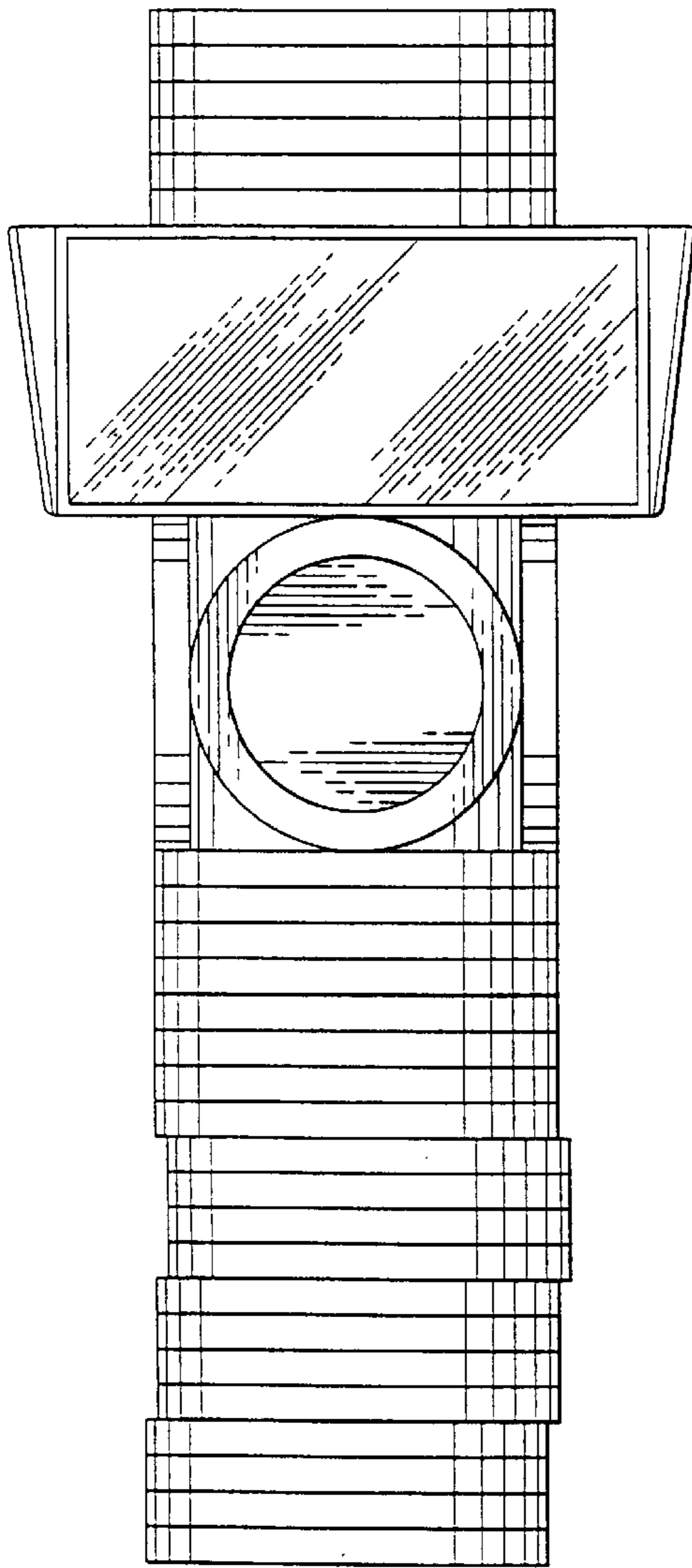

FIG. 3

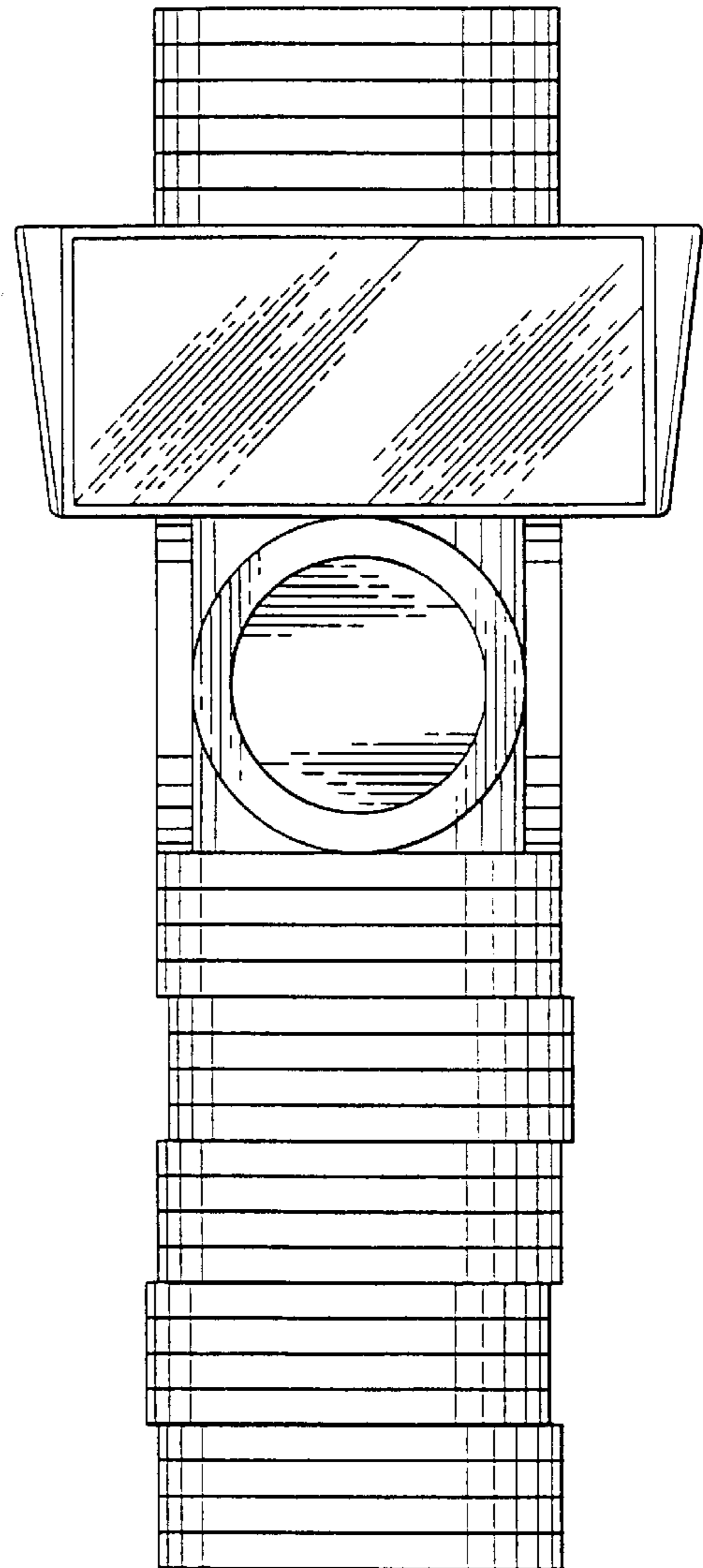

FIG. 4

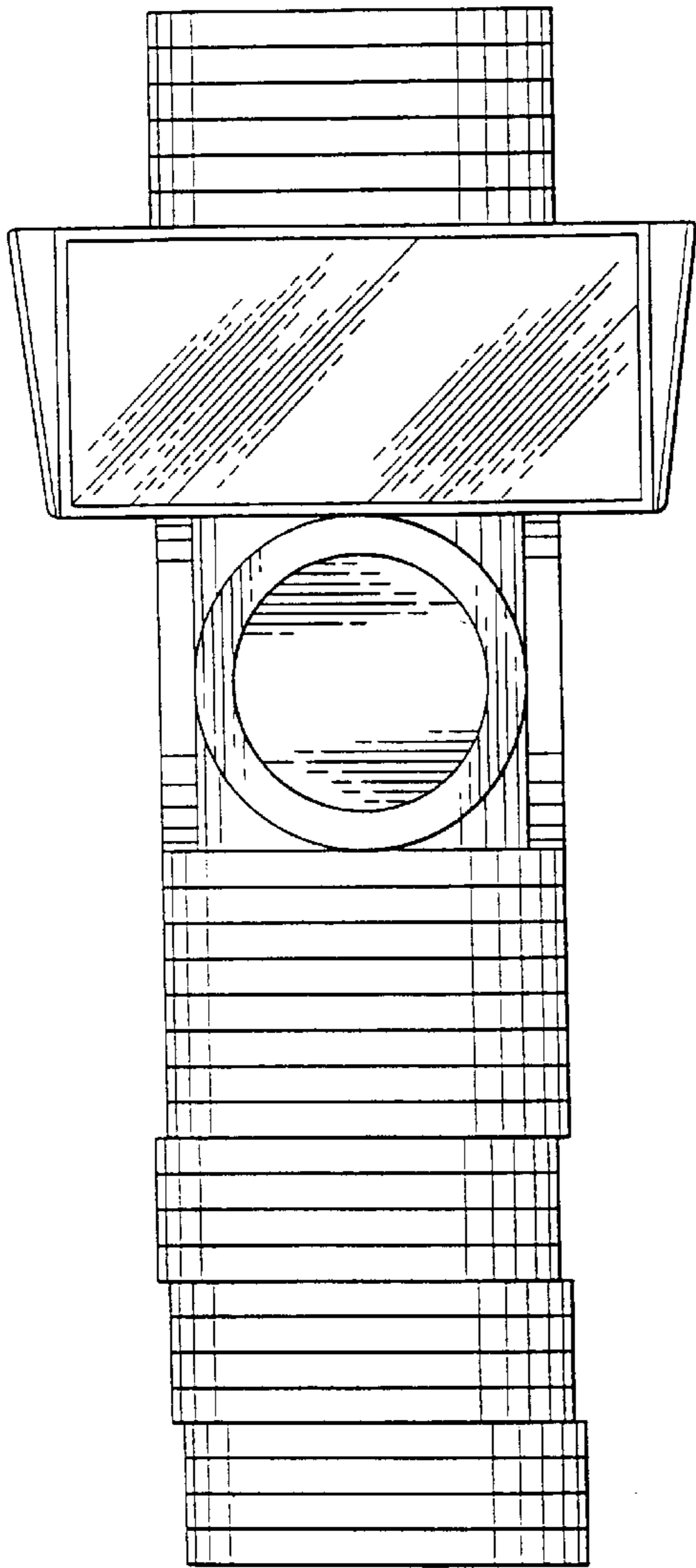

FIG. 5

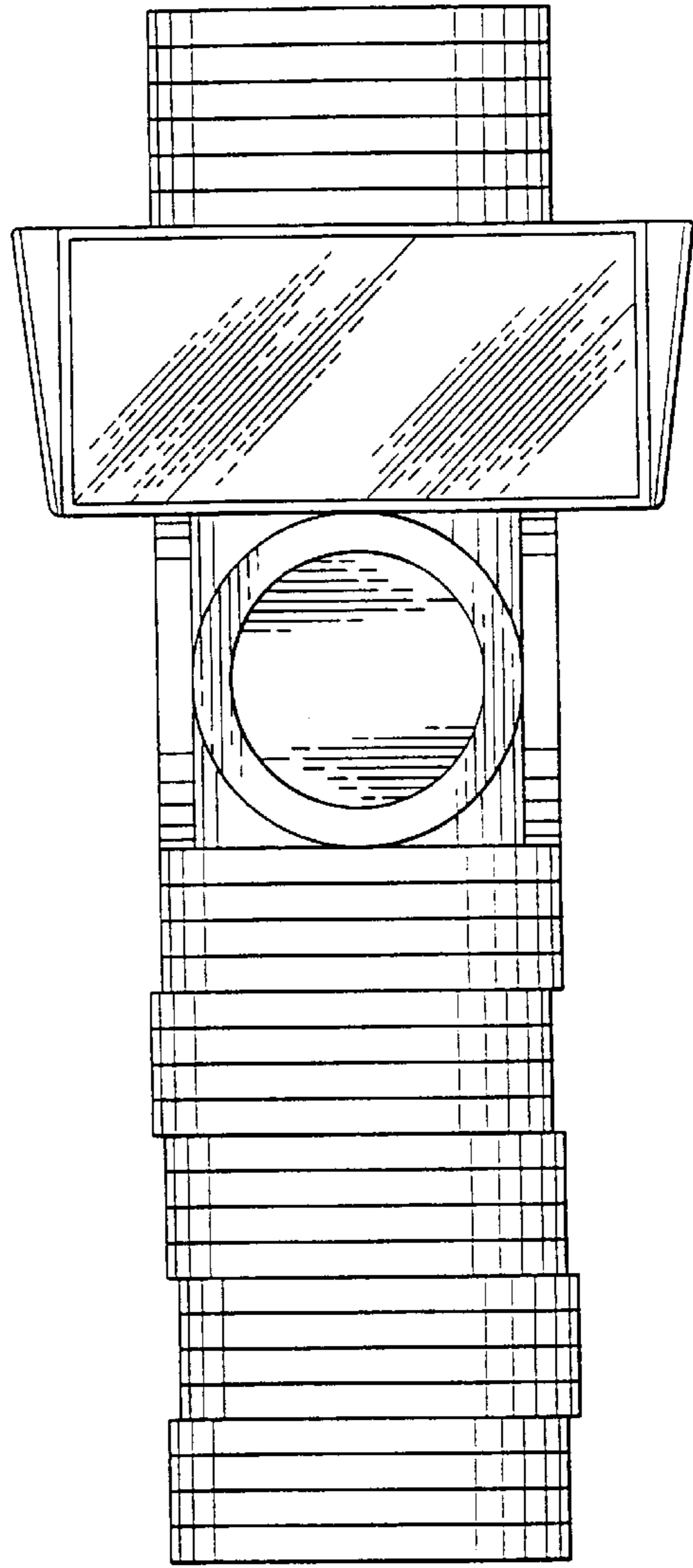

FIG. 6

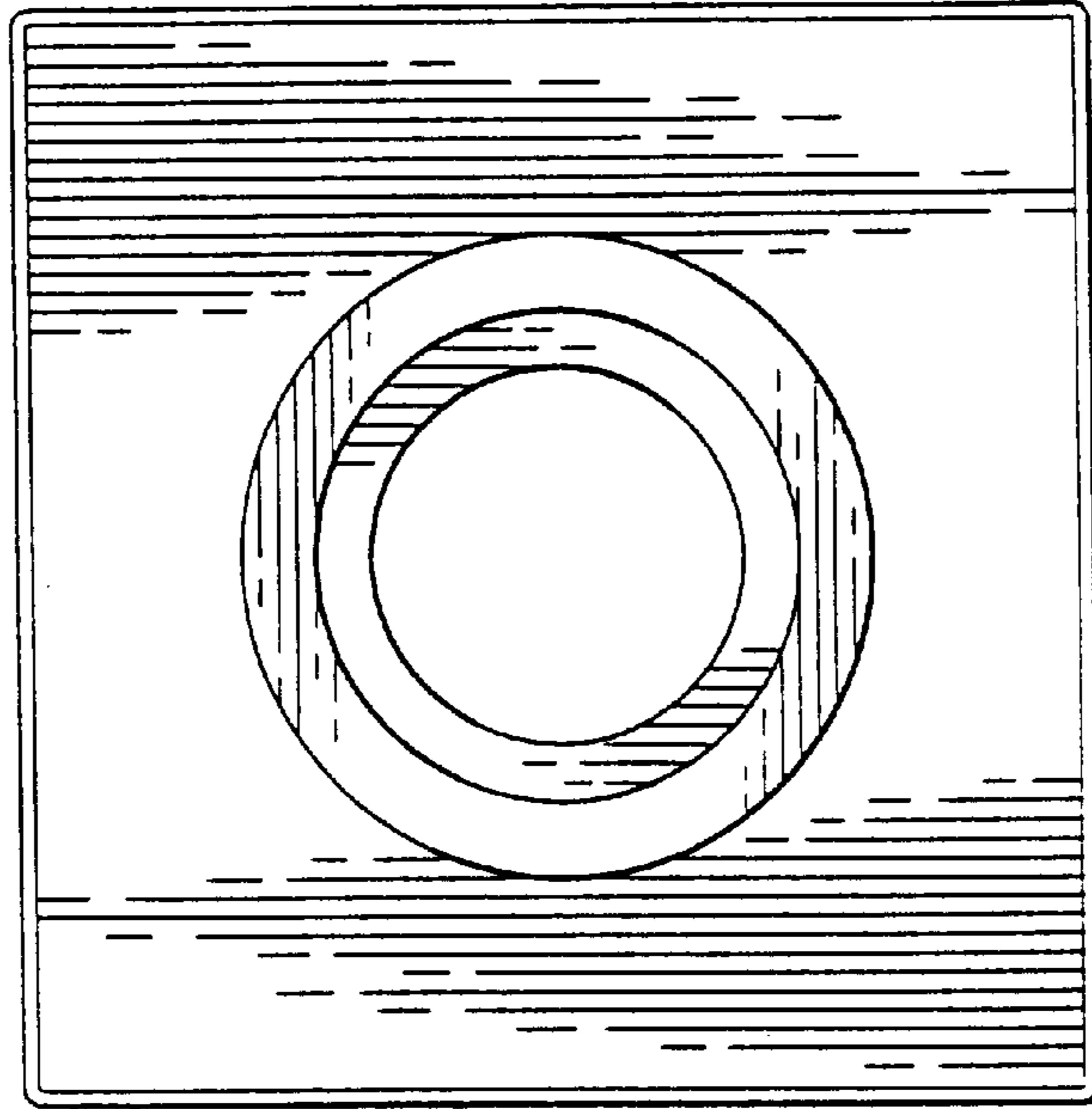

FIG. 7

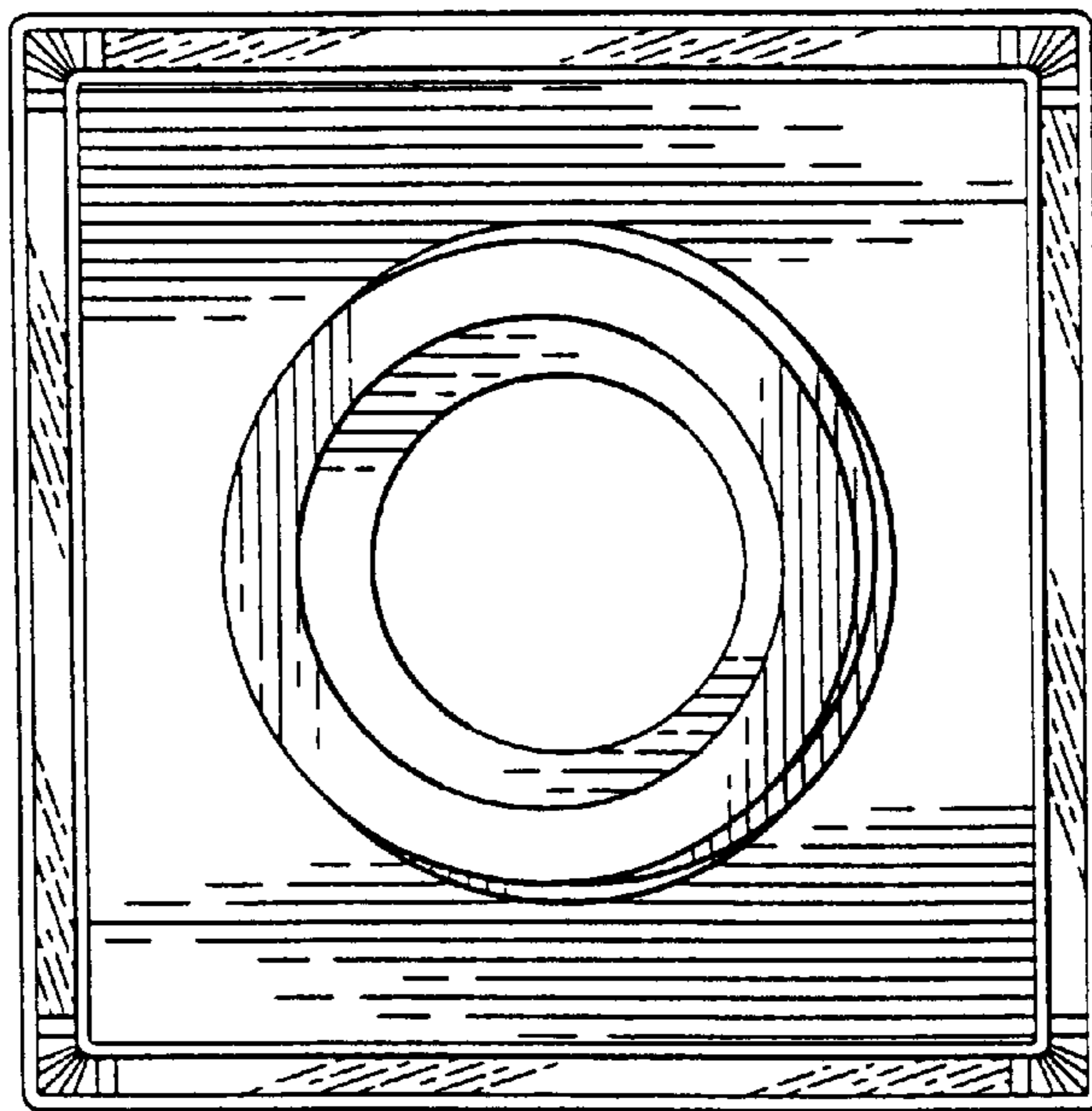

FIG. 8

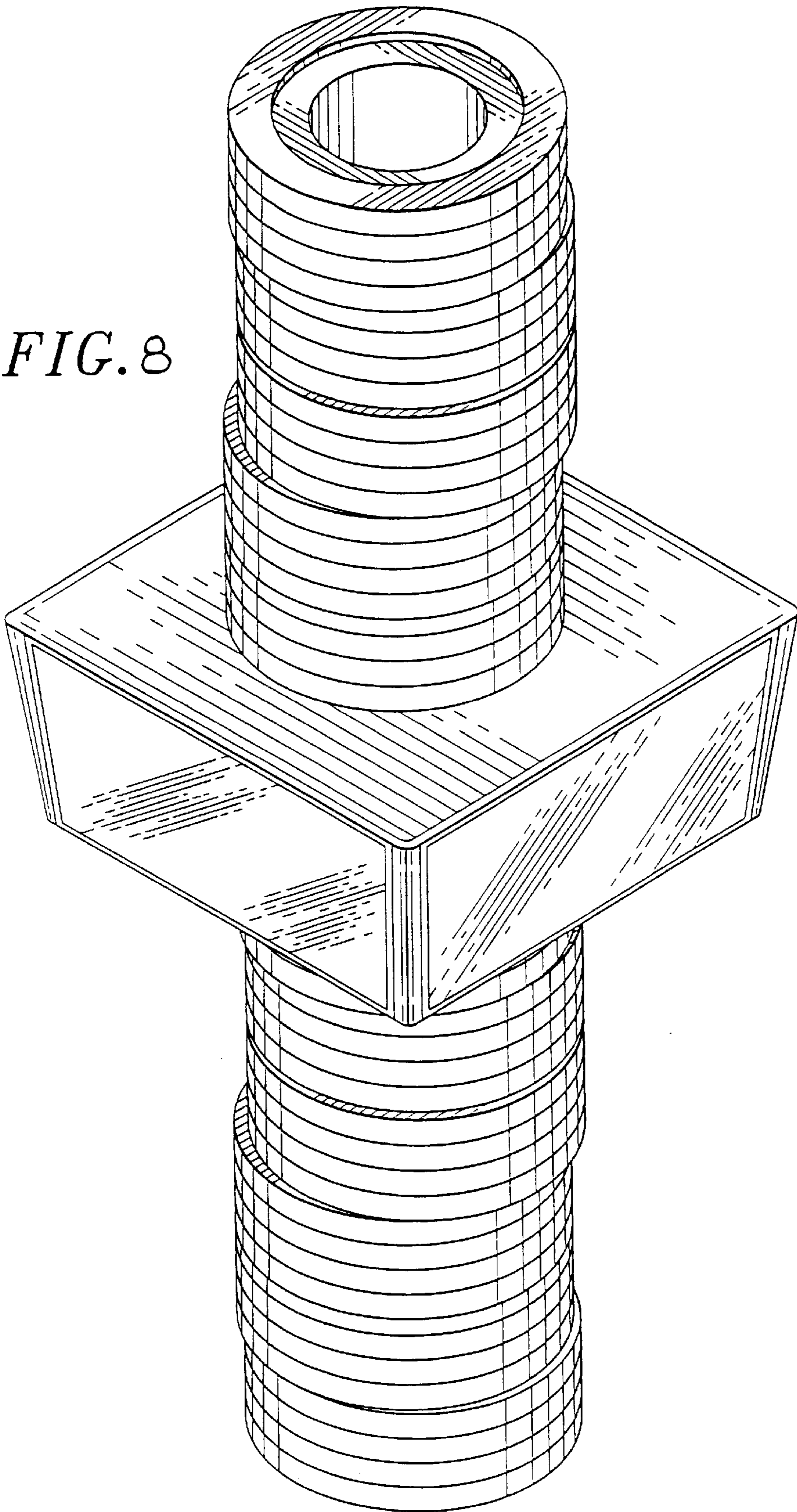

FIG. 9

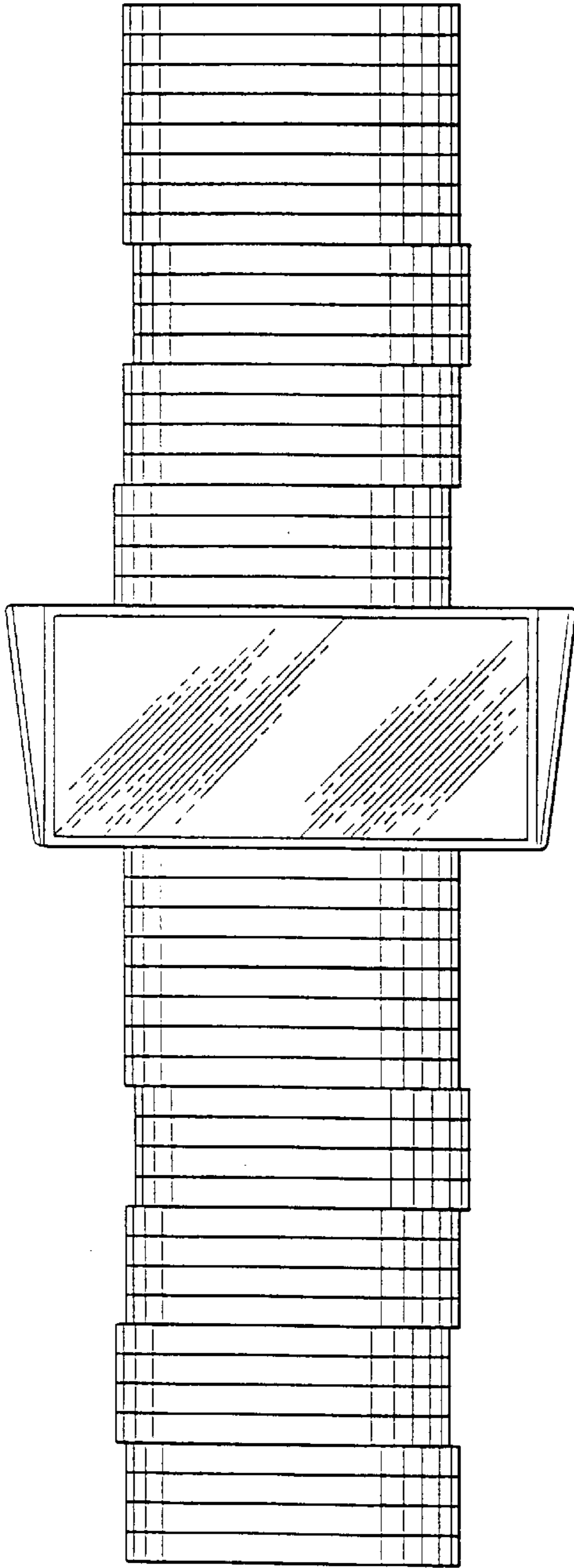

FIG. 10

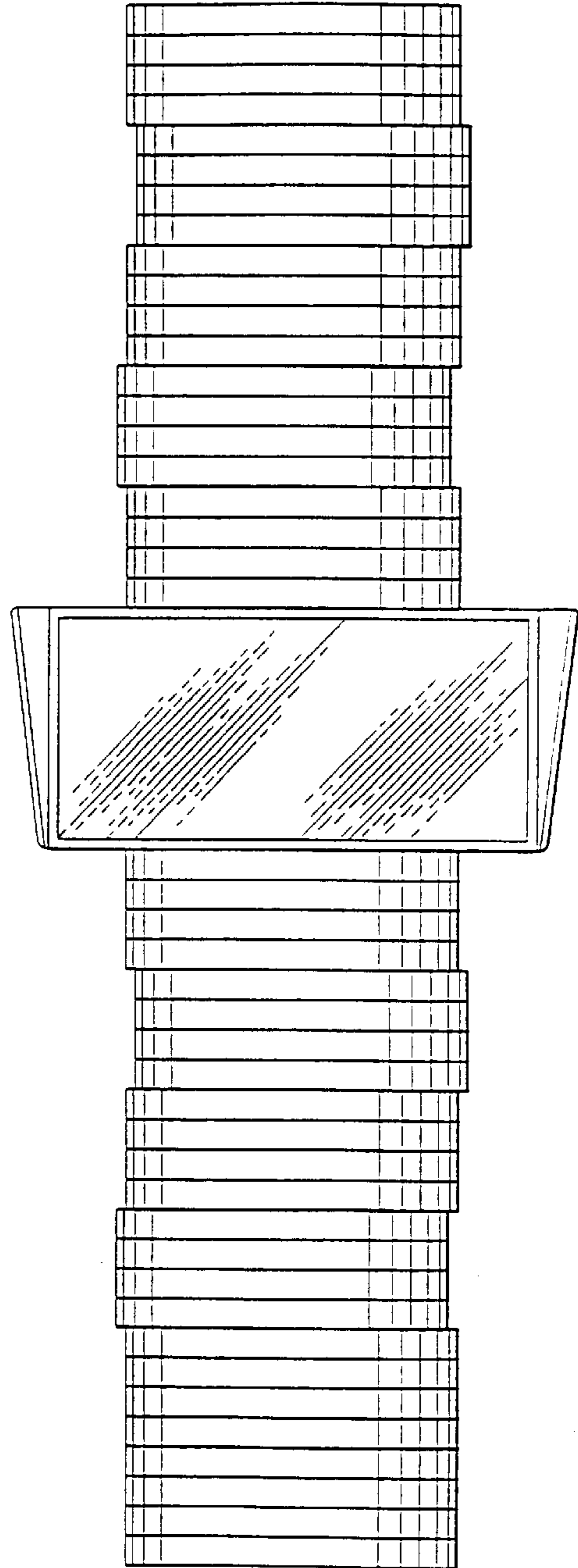

FIG. 11

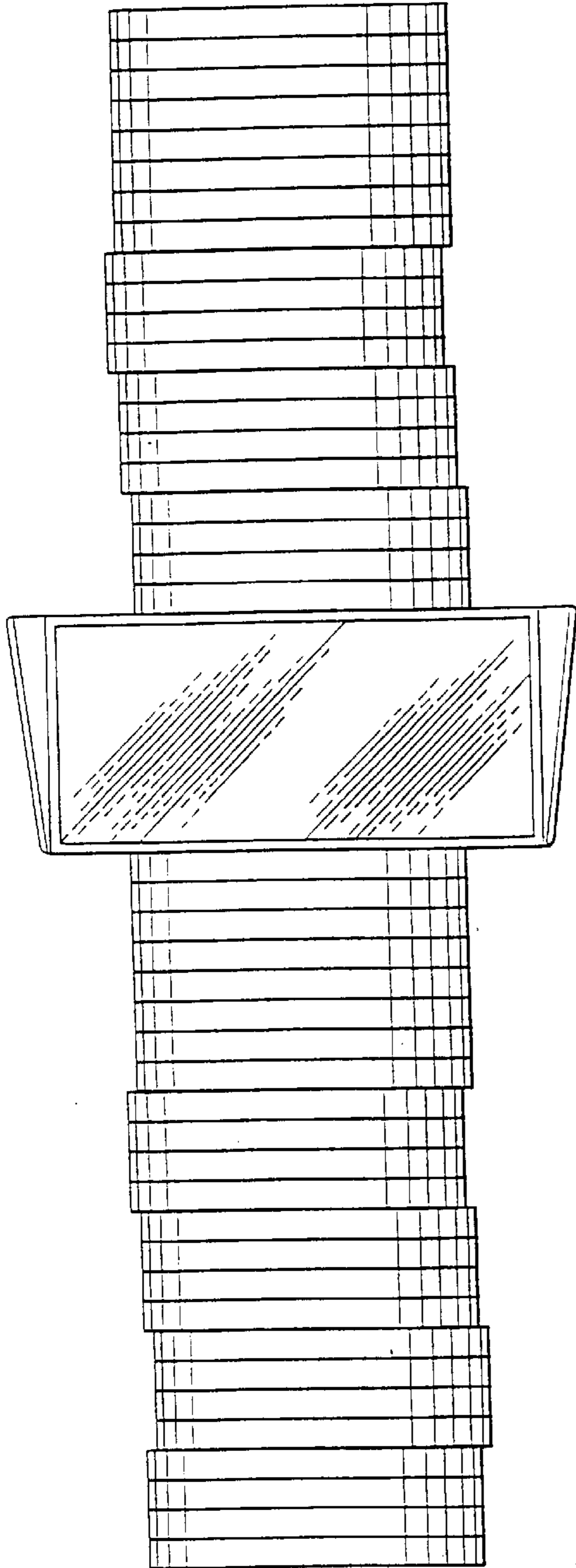

FIG. 12

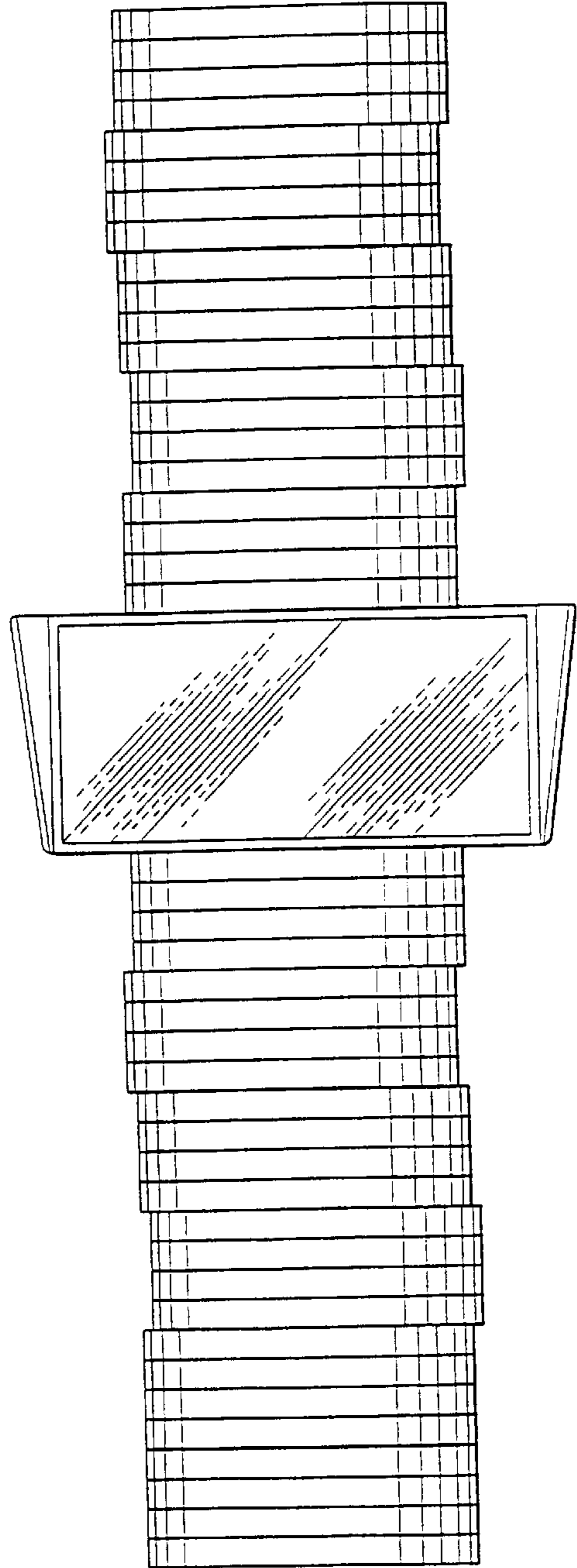

FIG. 13

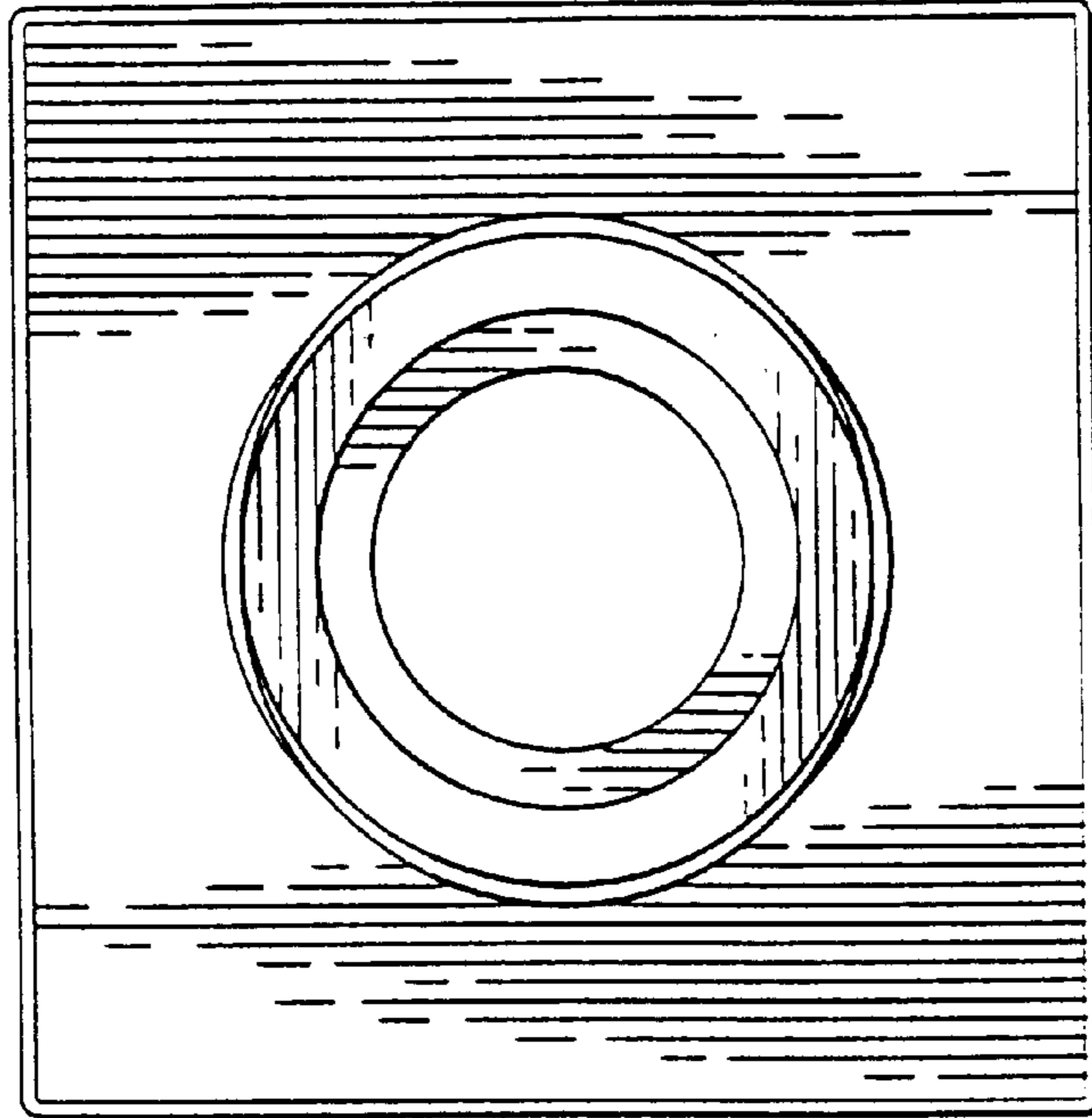

FIG. 14

