



US00D416227S

United States Patent [19]
Egan

[11] **Patent Number: Des. 416,227**

[45] **Date of Patent: ** Nov. 9, 1999**

[54] **DYNA MOTOR MOUNT FAIRING**

1,531,152 3/1925 Steen 310/71 X

[75] Inventor: **Craig P. Egan**, Mississauga, Canada

Primary Examiner—Joel Sincavage
Attorney, Agent, or Firm—Hessian & McKasy, P.A.; Glen E. Schumann

[73] Assignee: **KuryAkyn Holdings, Inc.**, Somerset, Wis.

[**] Term: **14 Years**

[57] **CLAIM**

The ornamental design for the dyna motor mount fairing, as shown and described.

[21] Appl. No.: **29/084,991**

[22] Filed: **Feb. 27, 1998**

DESCRIPTION

[51] **LOC (6) Cl.** **13-02**

[52] **U.S. Cl.** **D13/122**

[58] **Field of Search** D13/118, 122;
310/114, 64, 90

FIG. 1 is a view in perspective as seen from the top and two sides of a motor mount fairing showing my (our) design; FIG. 2 is a side elevation, the side opposite being a mirror image;

FIG. 3 is a front elevation;

FIG. 4 is a rear elevation;

FIG. 5 is a top plan; and,

FIG. 6 is a bottom plan.

[56] **References Cited**

U.S. PATENT DOCUMENTS

D. 275,478 9/1984 Griggs D13/122

D. 325,561 4/1992 Wilson D13/118

1 Claim, 4 Drawing Sheets

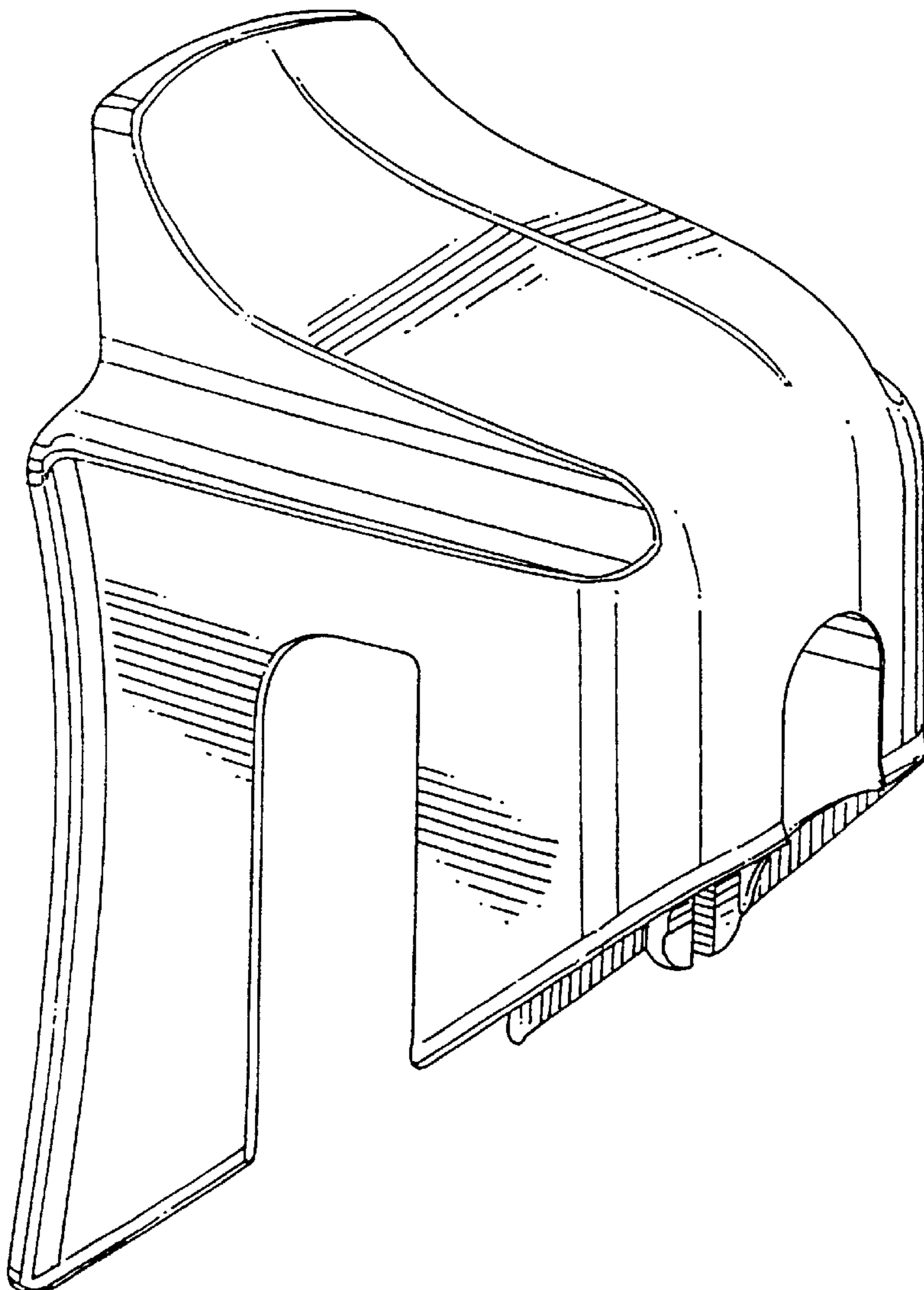

FIG. 1

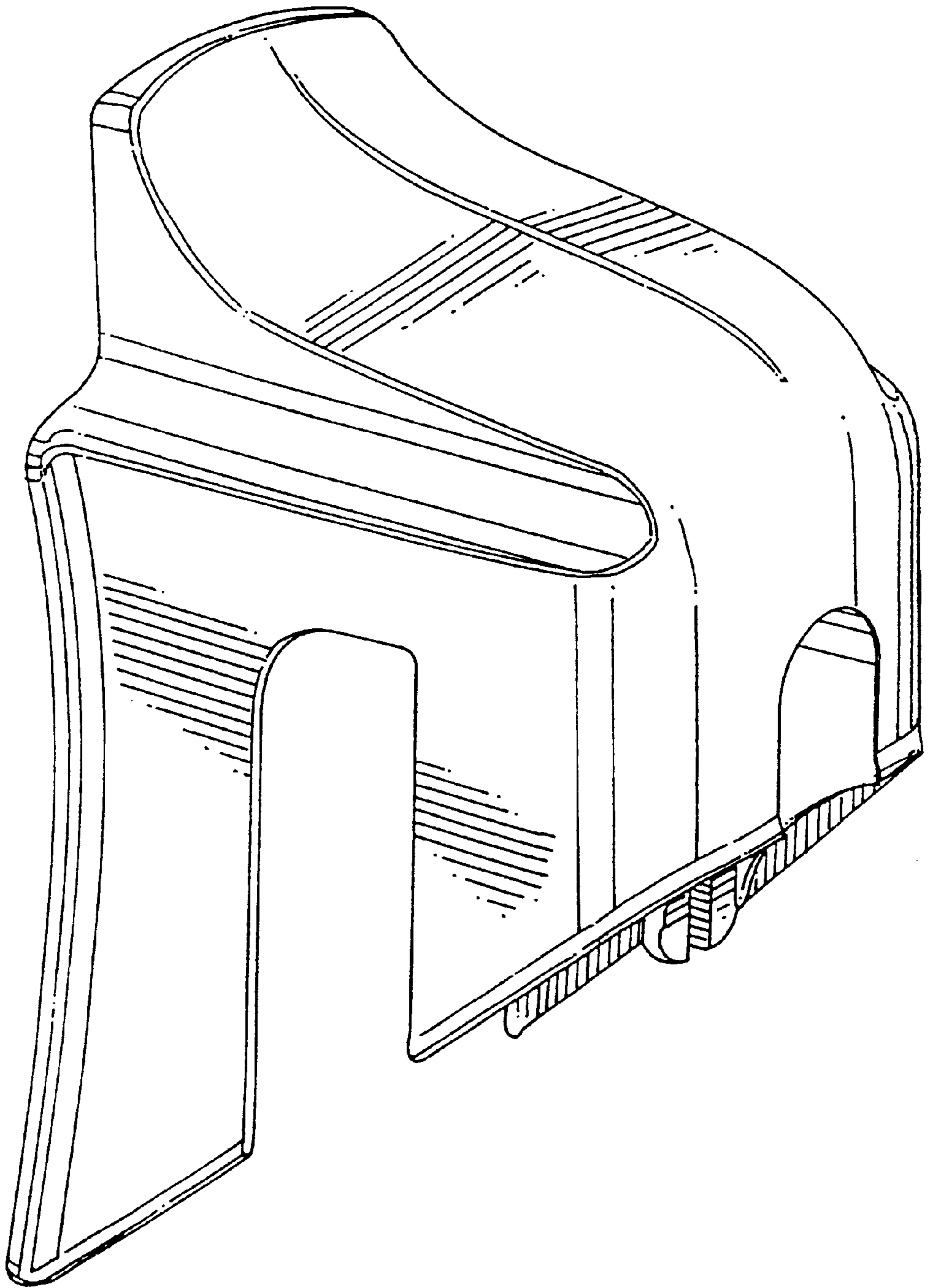

FIG. 2

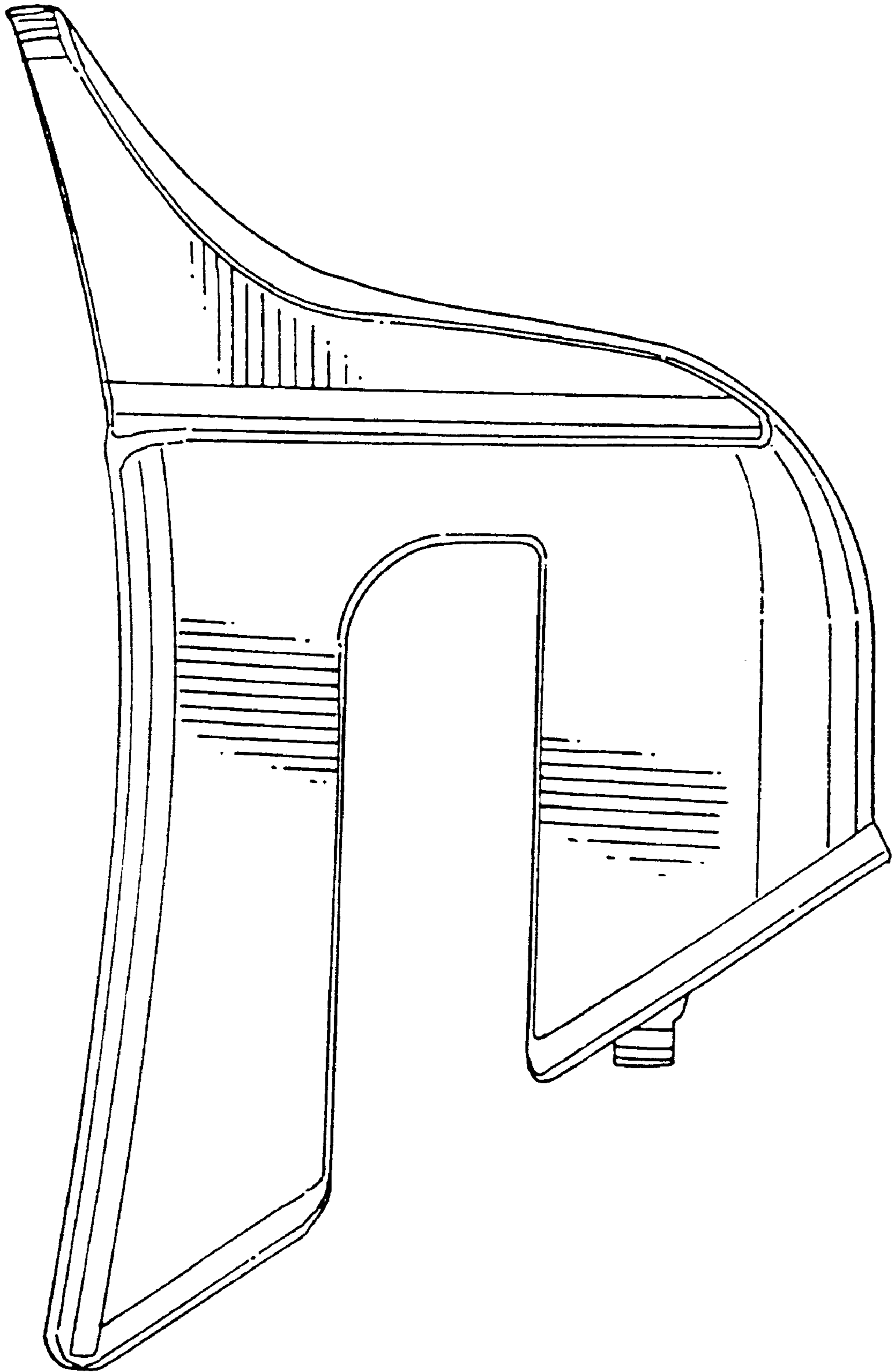

FIG. 4

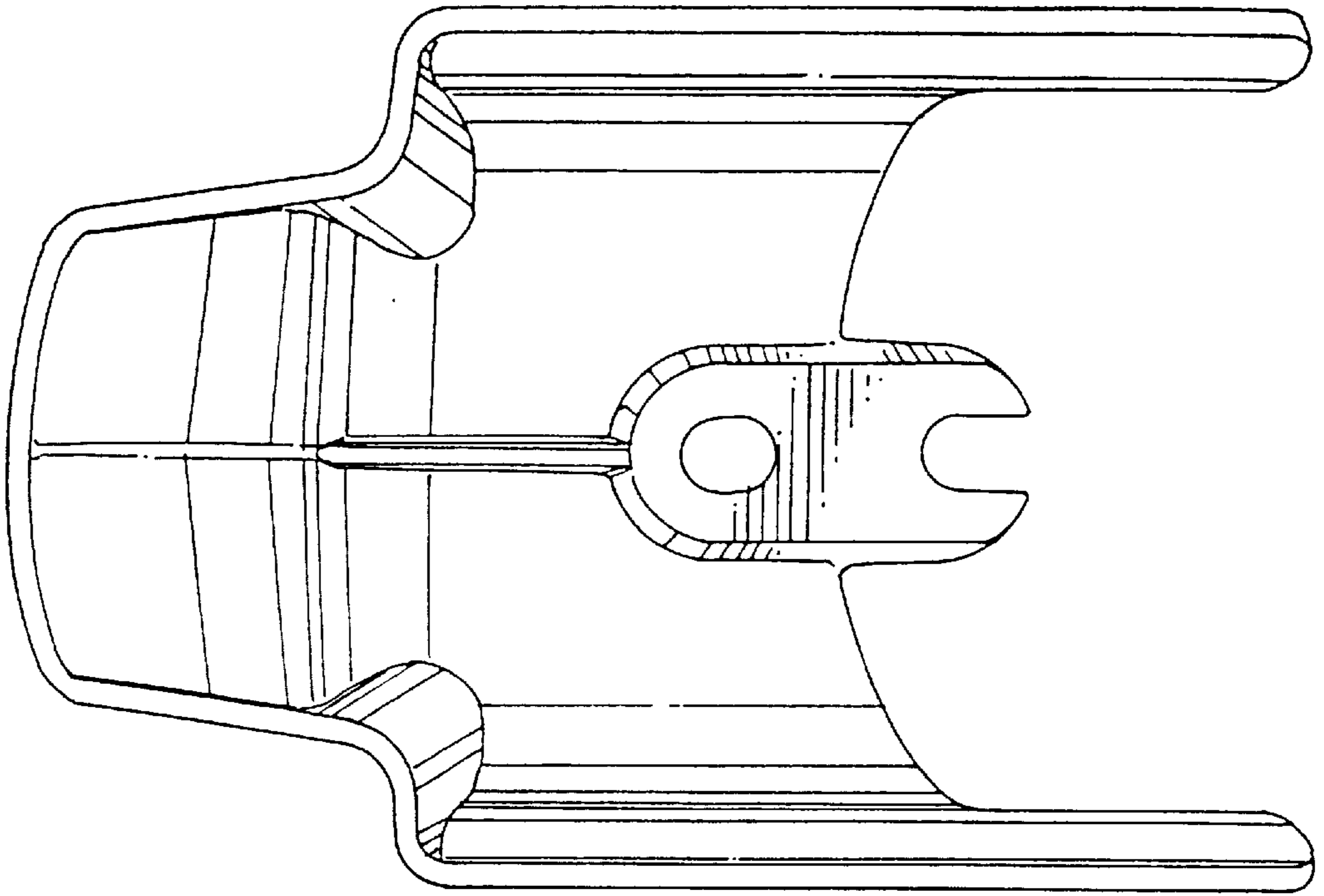

FIG. 3

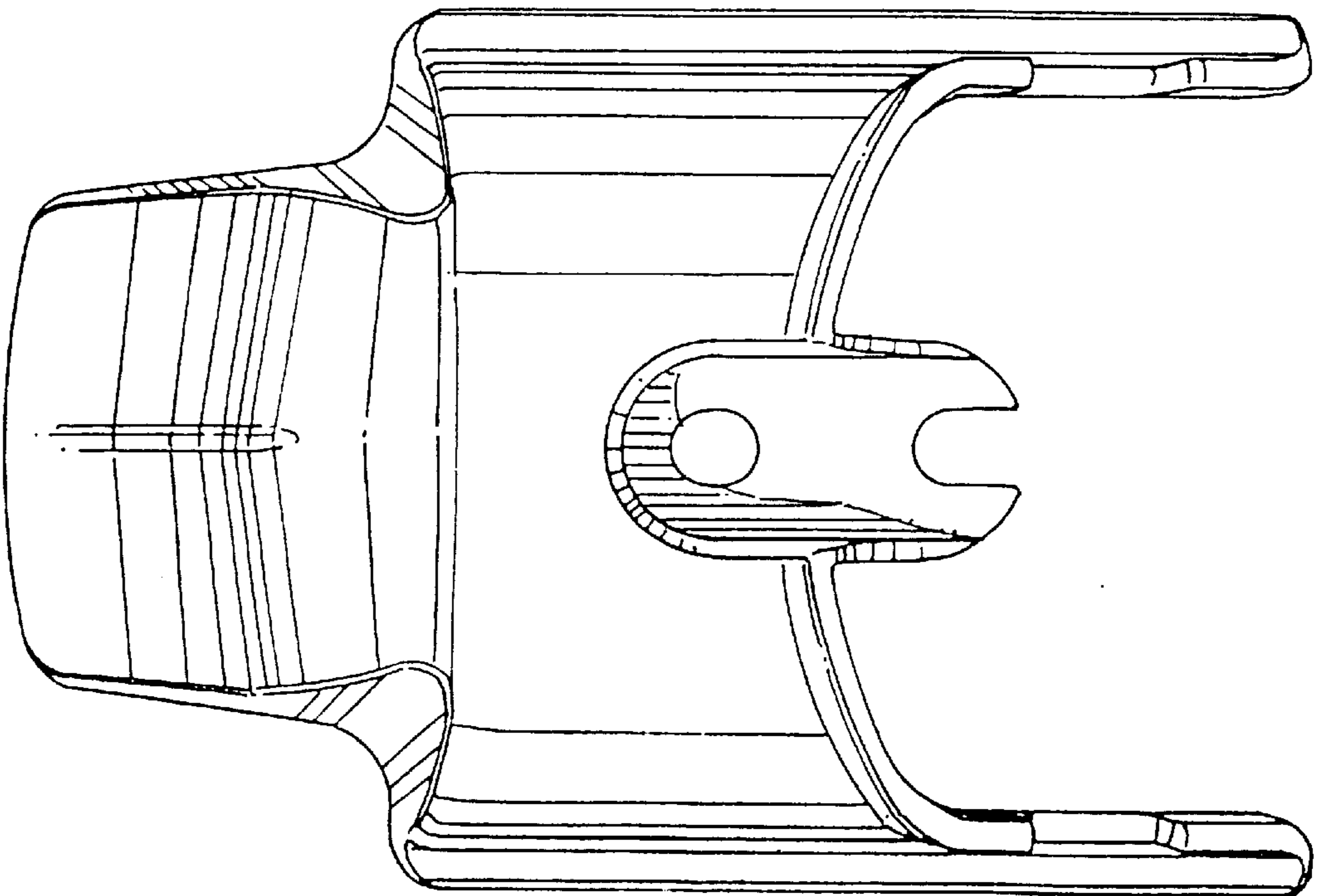

FIG. 6

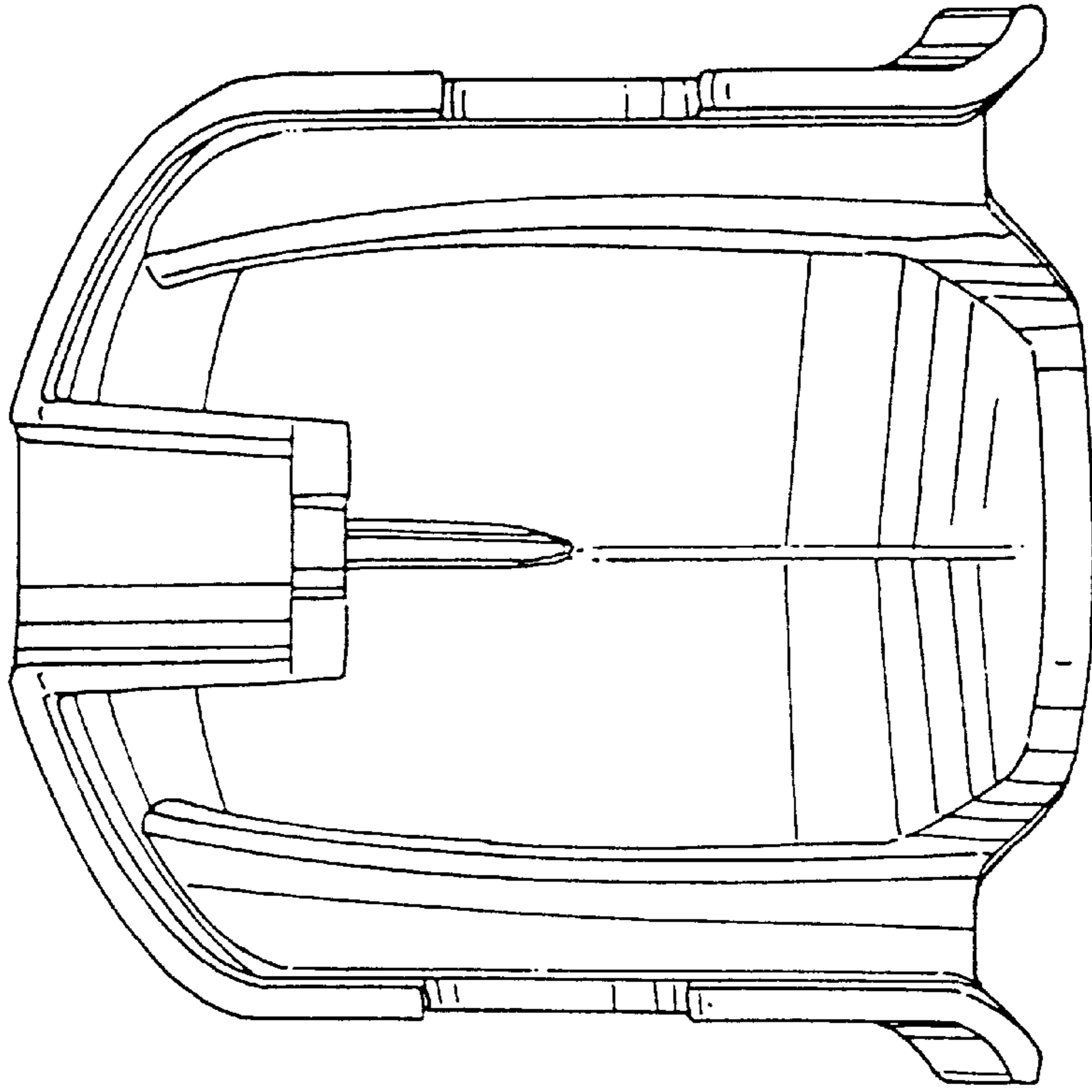

FIG. 5

