



US00D416220S

United States Patent [19]
Danielson

[11] **Patent Number: Des. 416,220**

[45] **Date of Patent: ** Nov. 9, 1999**

[54] **PADDED PROTECTIVE GRATING FOR A TRUCK REAR WINDOW**

3,053,566 9/1962 Allen 296/106
4,953,908 9/1990 Dondlinger 296/97.4

[76] Inventor: **Carl E Danielson**, 3636 S. Sheridan, Tacoma, Wash. 98408

Primary Examiner—Doris V. Coles
Assistant Examiner—Stacia Sinuik

[**] Term: **14 Years**

[57] **CLAIM**

[21] Appl. No.: **29/089,244**

The ornamental design for a padded protective grating for a truck rear window, as shown.

[22] Filed: **Jun. 11, 1998**

DESCRIPTION

[51] **LOC (6) Cl.** **12-16**

[52] **U.S. Cl.** **D12/183**

[58] **Field of Search** D12/167, 181–183, D12/190–191, 222, 401, 98, 414; 296/1.1, 95.1, 97.4, 106; 280/748, 762, 770; 49/64; 160/370.21, 371, 105, 354

FIG. 1 is a front elevational view of the padded protective grating for a truck rear window of the present invention; FIG. 2 is a back elevational view of the padded protective grating for a truck rear window of FIG. 1; FIG. 3 is a left side elevational view of the padded protective grating for a truck rear window of FIG. 1; FIG. 4 is a right side elevational view of the padded protective grating for a truck rear window of FIG. 1; FIG. 5 is a top plan view of the padded protective grating for a truck rear window of FIG. 1; FIG. 6 is a bottom plan view of the padded protective grating for a truck rear window of FIG. 1; and, FIG. 7 is a perspective view of the padded protective grating for a truck rear window of FIG. 1.

[56] **References Cited**

U.S. PATENT DOCUMENTS

D. 206,654	1/1967	Smith	D12/414
D. 336,458	6/1993	D'Alessandro	D12/183
D. 371,759	7/1996	Larsen	D12/183
D. 381,304	7/1997	Ruimi	D12/183
D. 388,385	12/1997	Protz, Sr.	D12/183 X
2,799,530	7/1957	Drake	296/106
2,819,499	1/1958	Abramson et al.	D12/183 X

1 Claim, 4 Drawing Sheets

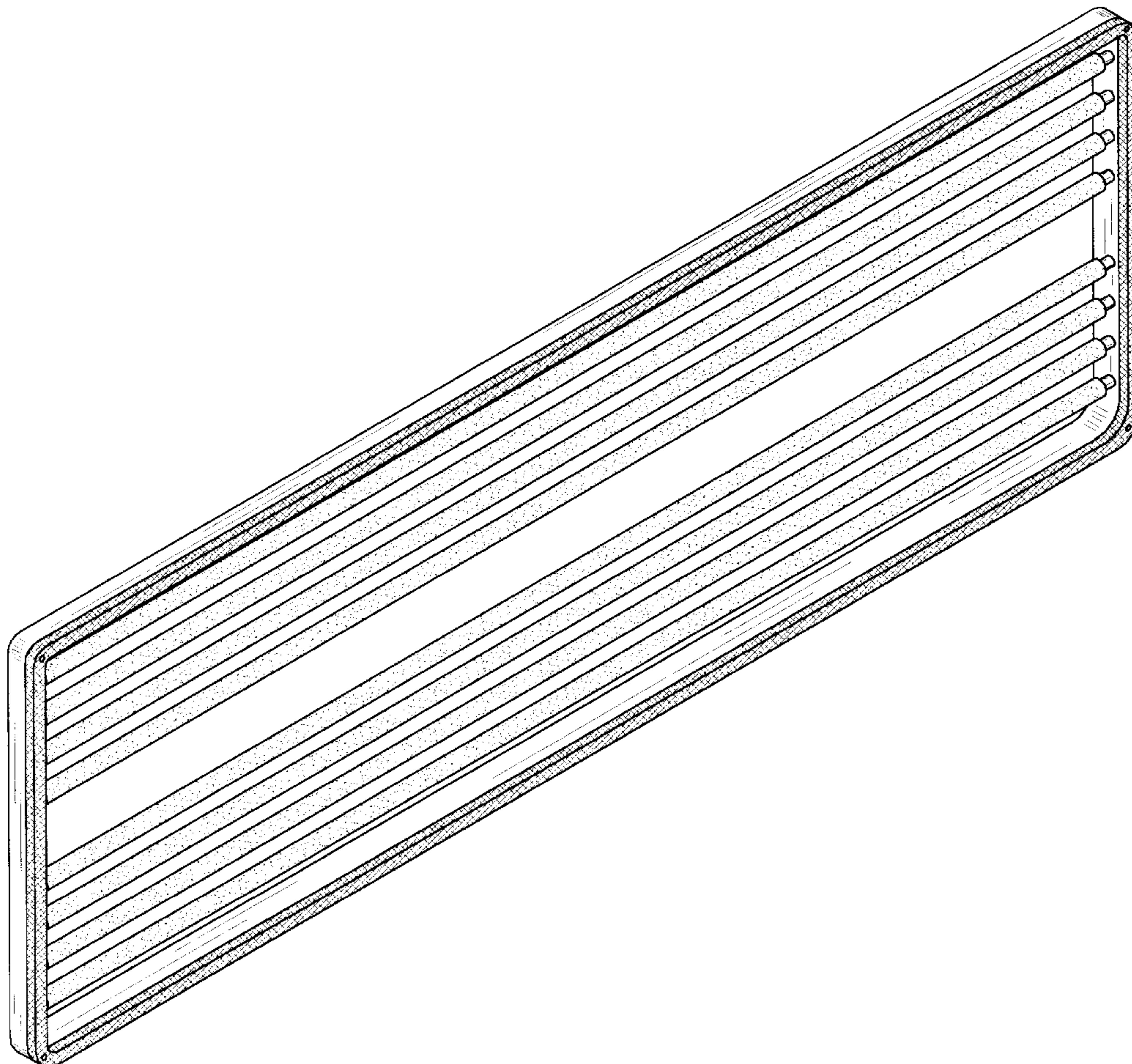

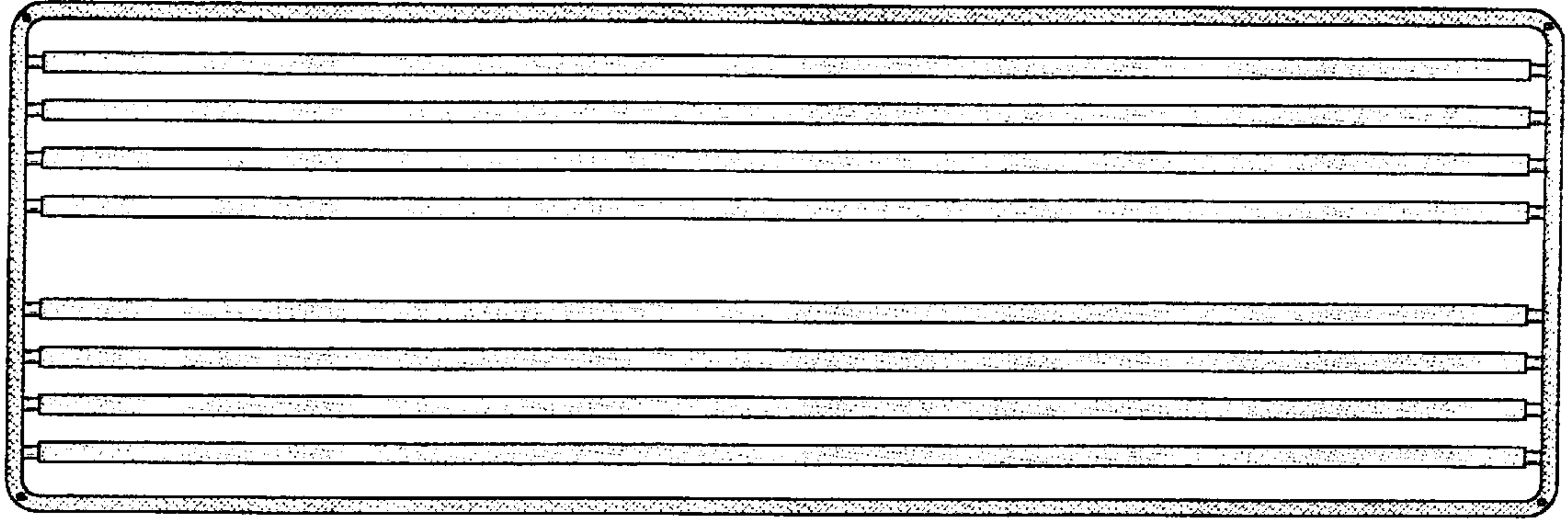

Fig. 1

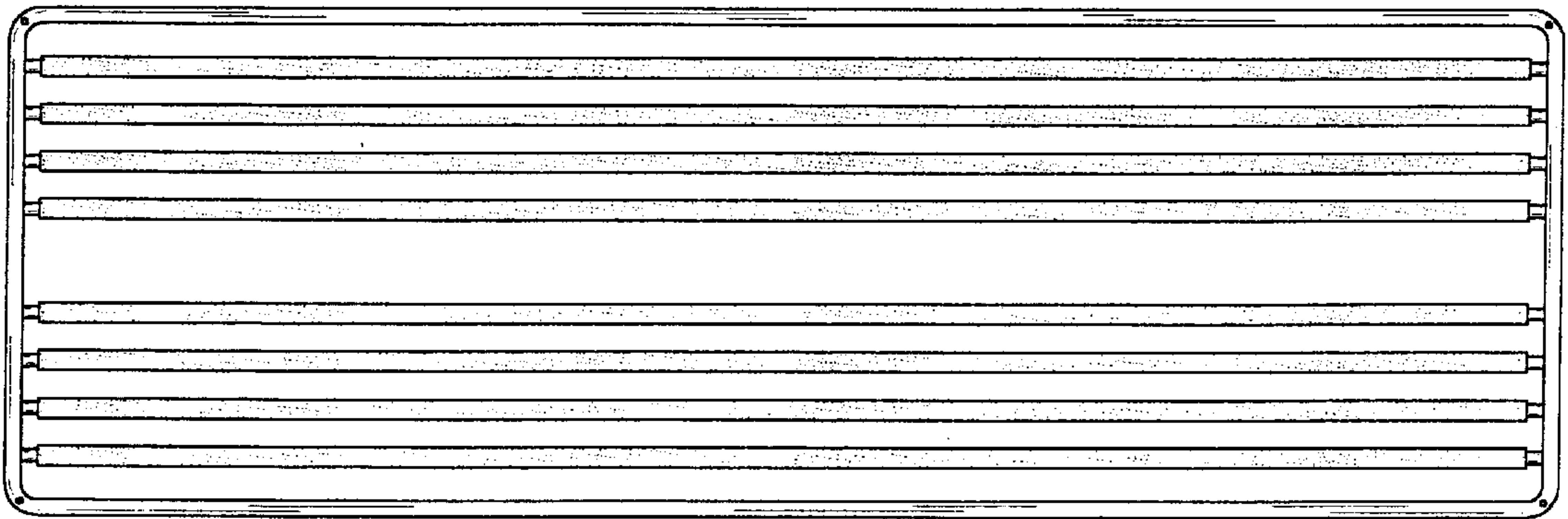

Fig. 2



Fig. 3



Fig. 4

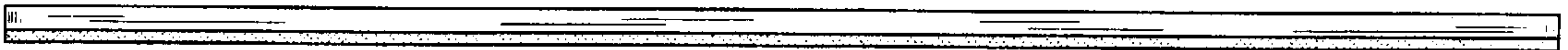

Fig. 5

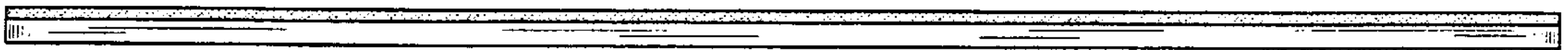

Fig. 6

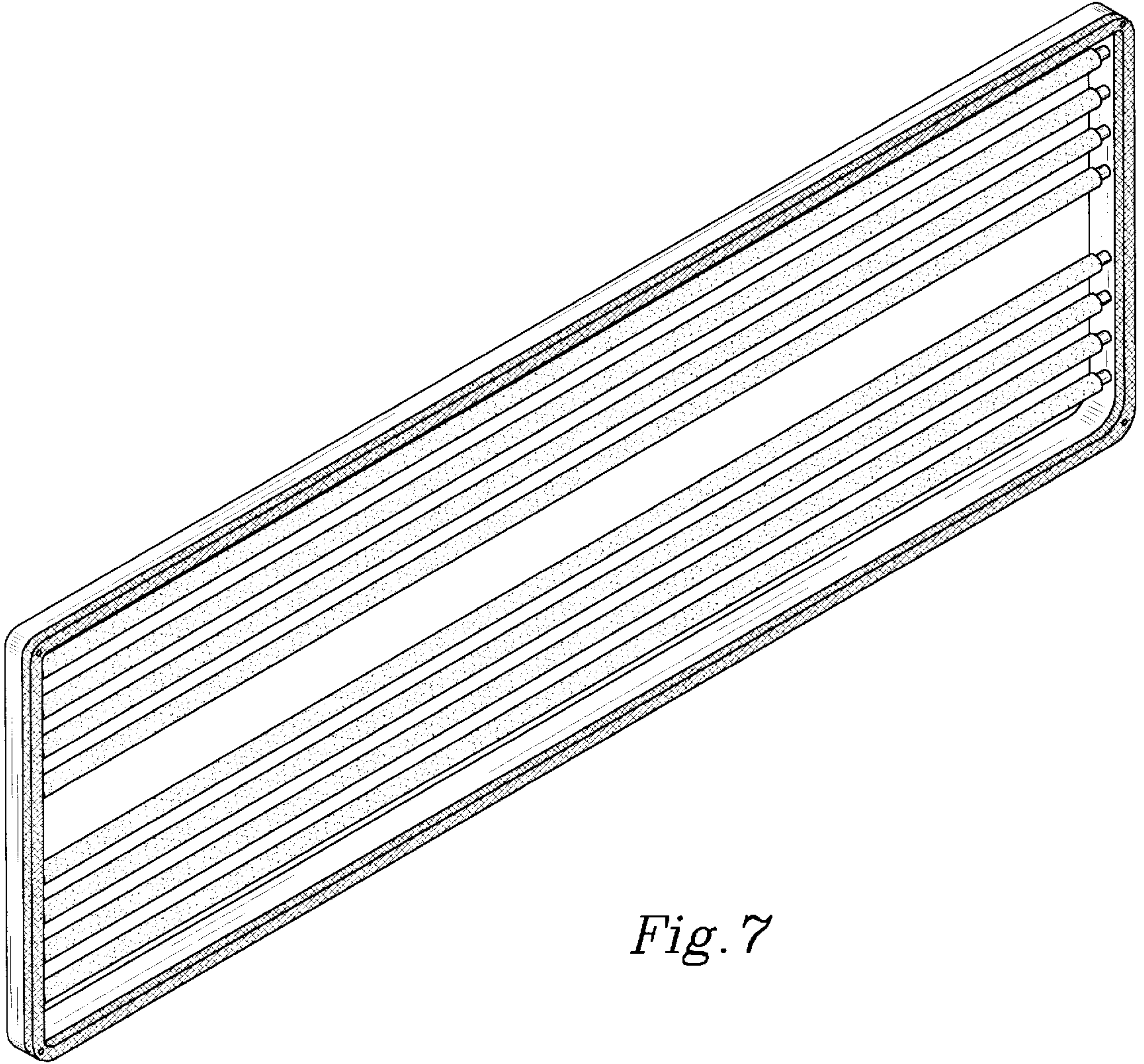

Fig. 7