



US00D416215S

United States Patent [19]

[11] **Patent Number: Des. 416,215**

Hanlon et al.

[45] **Date of Patent: ** Nov. 9, 1999**

[54] **MOTORCYCLE**

[56] **References Cited**

[75] Inventors: **Daniel L. Hanlon**, Burnsville; **David P. Hanlon**; **Jennie L. Hanlon**, both of Apple Valley; **Anthony N. Pink**, Prior Lake, all of Minn.

U.S. PATENT DOCUMENTS

D. 385,227 10/1997 Katoh D12/110
D. 392,601 3/1998 Ban et al. D12/110
D. 395,621 6/1998 Nishino D12/110

[73] Assignee: **Excelsior-Henderson Motorcycle Manufacturing Company**, Belle Plaine, Minn.

Primary Examiner—Pamela Burgess
Attorney, Agent, or Firm—Schwegman, Lundberg, Woessner & Kluth, P.A.

[**] Term: **14 Years**

[57] **CLAIM**

The ornamental design for a motorcycle, as shown and described.

[21] Appl. No.: **29/091,346**

DESCRIPTION

[22] Filed: **Jul. 28, 1998**

Related U.S. Application Data

FIG. 1 is a right side view of a motorcycle incorporating a design according to the invention.

[63] Continuation-in-part of application No. 29/074,382, Jul. 28, 1997, abandoned.

FIG. 2 is a left side view of the motorcycle of FIG. 1.

FIG. 3 is a top view of the motorcycle of FIG. 1.

FIG. 4 is a front view of the motorcycle of FIG. 1; and,

FIG. 5 is a rear view of the motorcycle of FIG. 1;

The broken lines in FIGS. 1-5 are shown for illustrative purposes only, and form no part of the claimed design.

[51] **LOC (6) Cl.** **12-11**

[52] **U.S. Cl.** **D12/110**

[58] **Field of Search** D12/114, 110,
D12/107; 180/219; 28/288.4

1 Claim, 5 Drawing Sheets

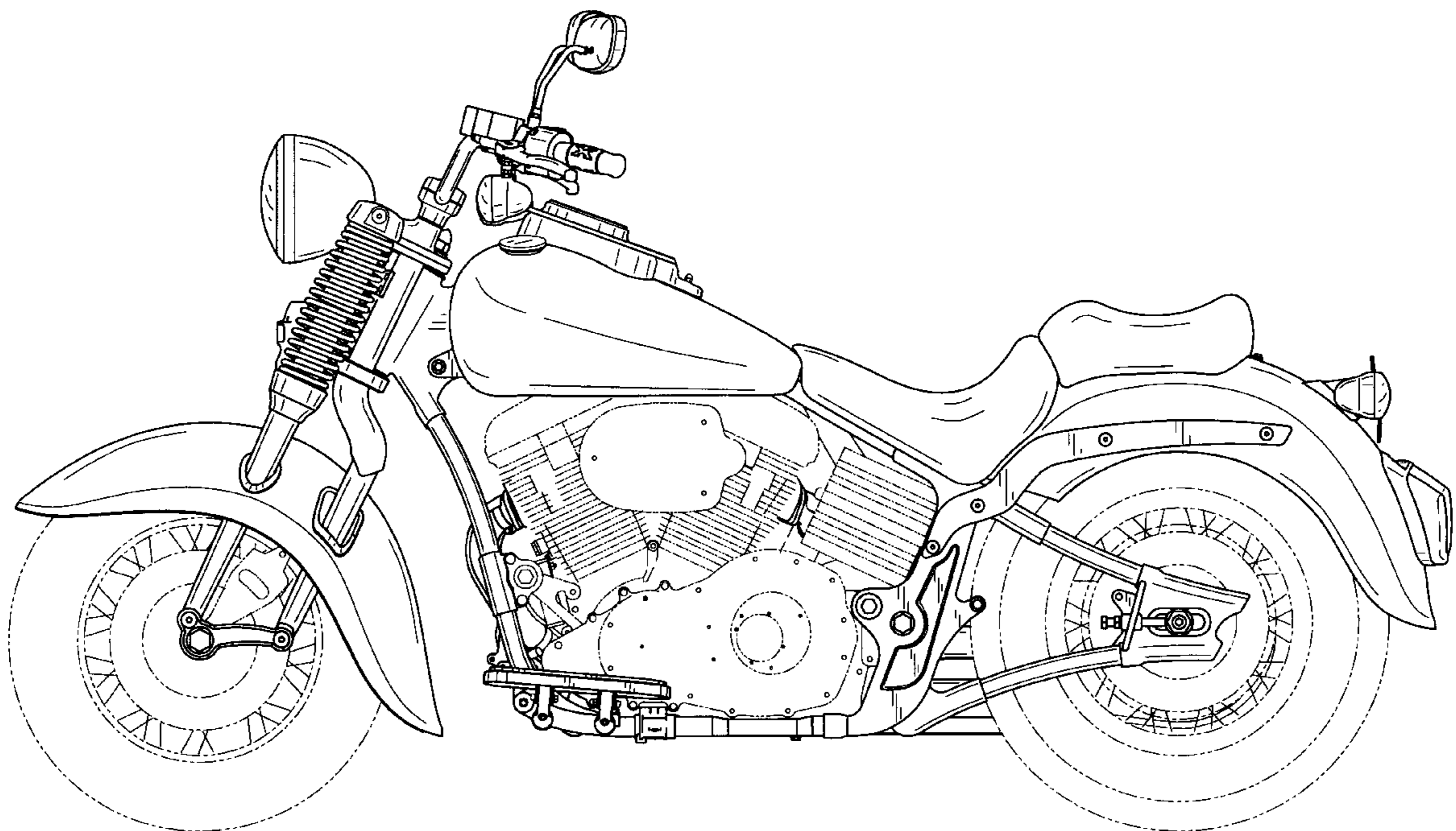

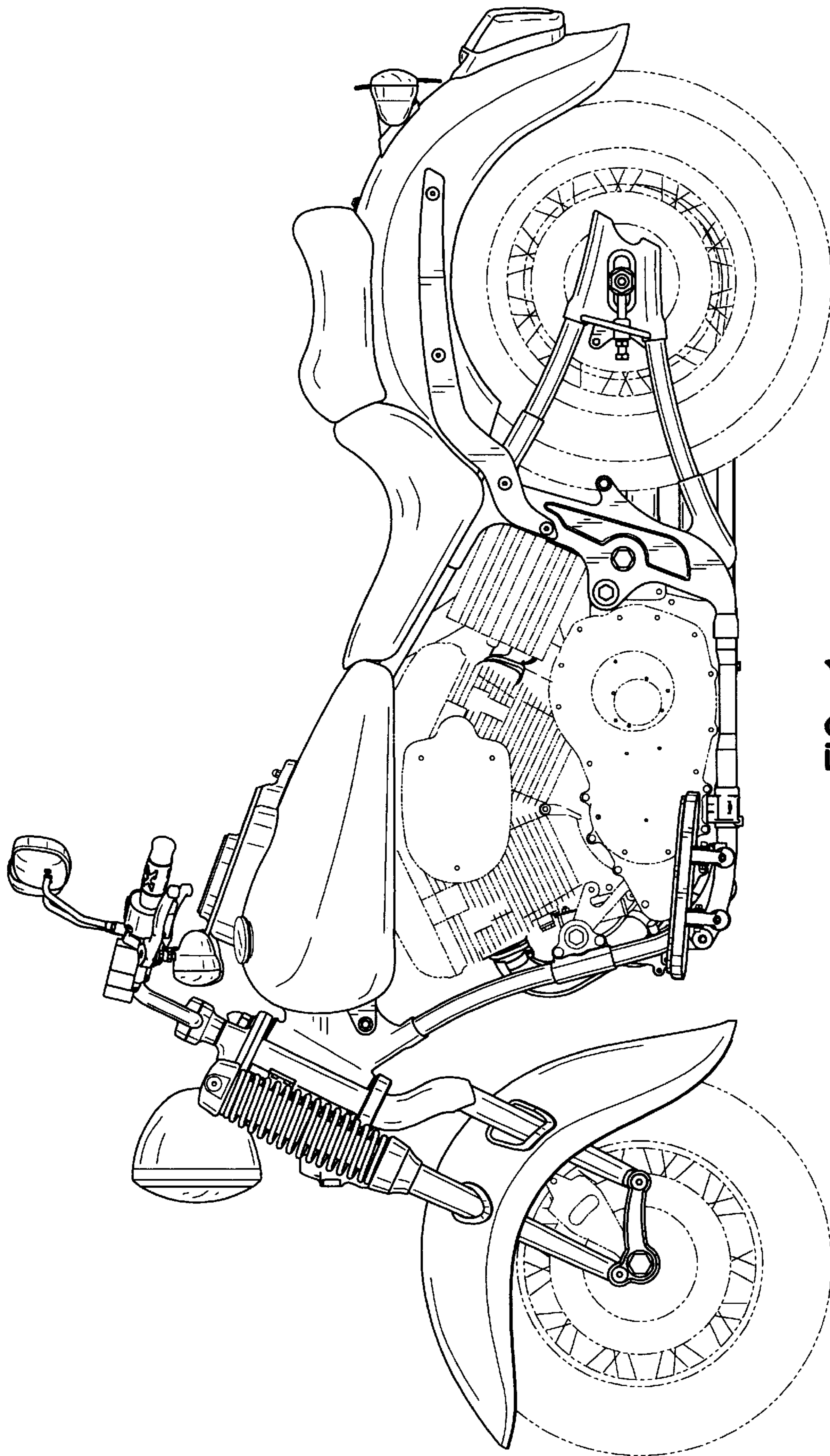

FIG. 1

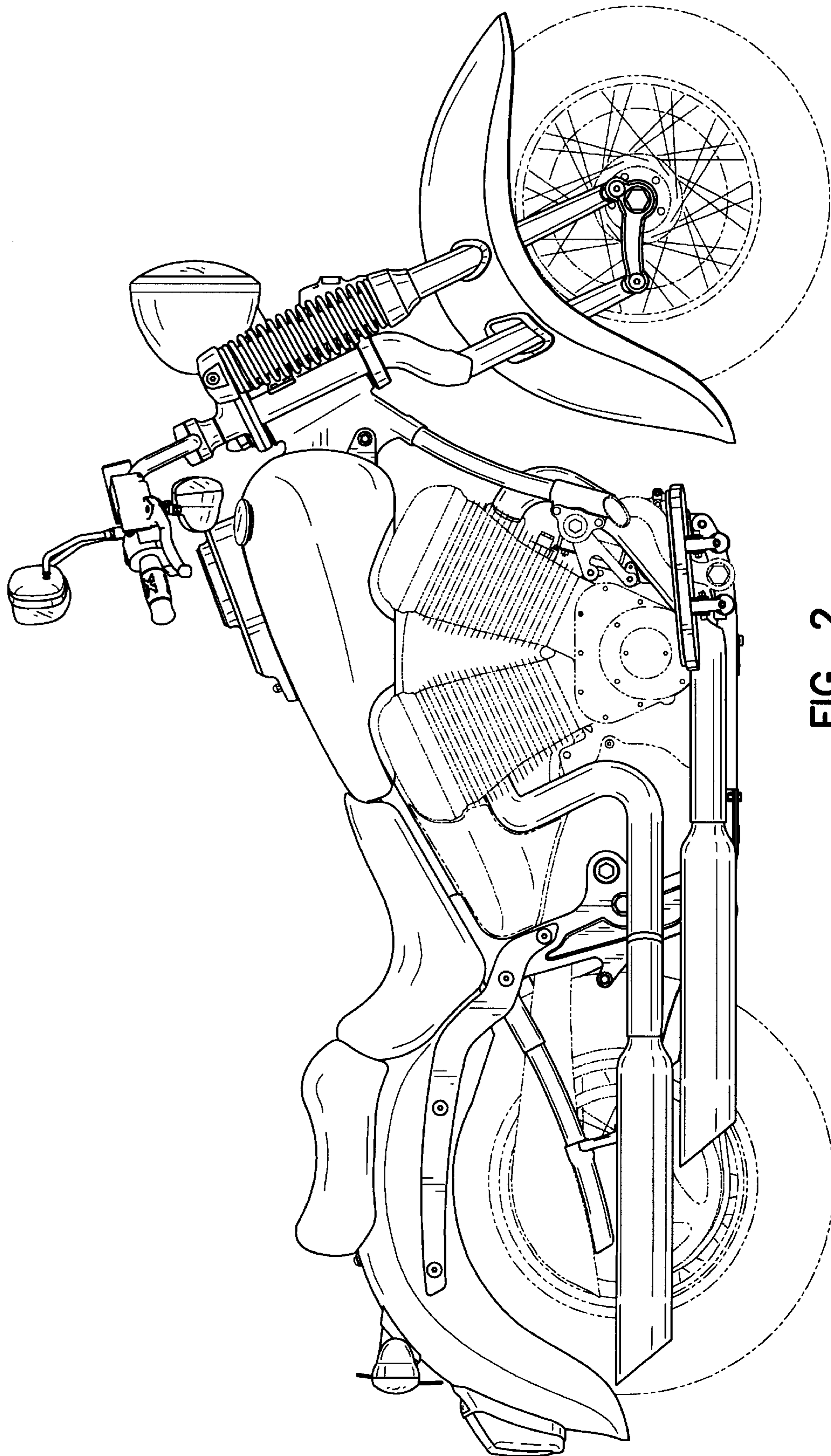

FIG. 2

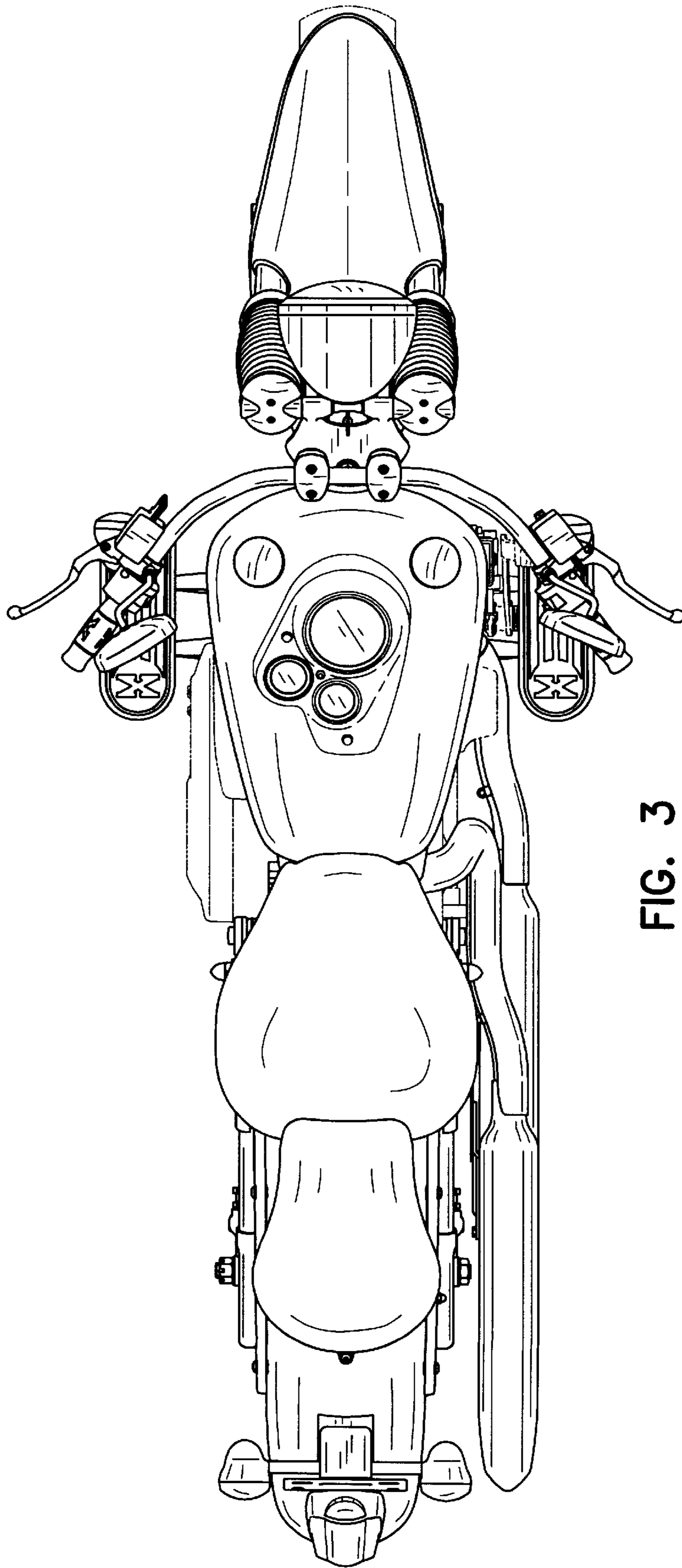

FIG. 3

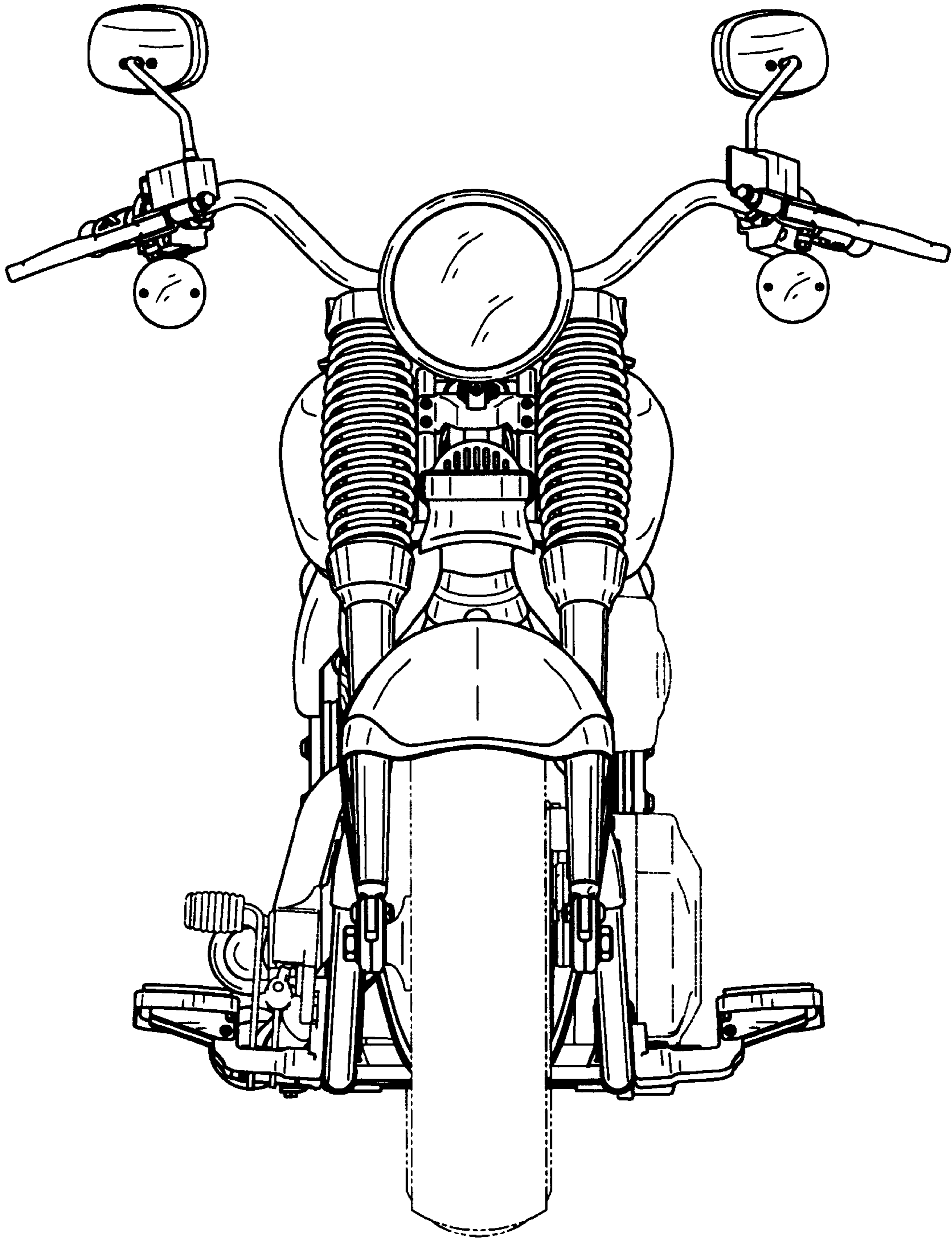

FIG. 4

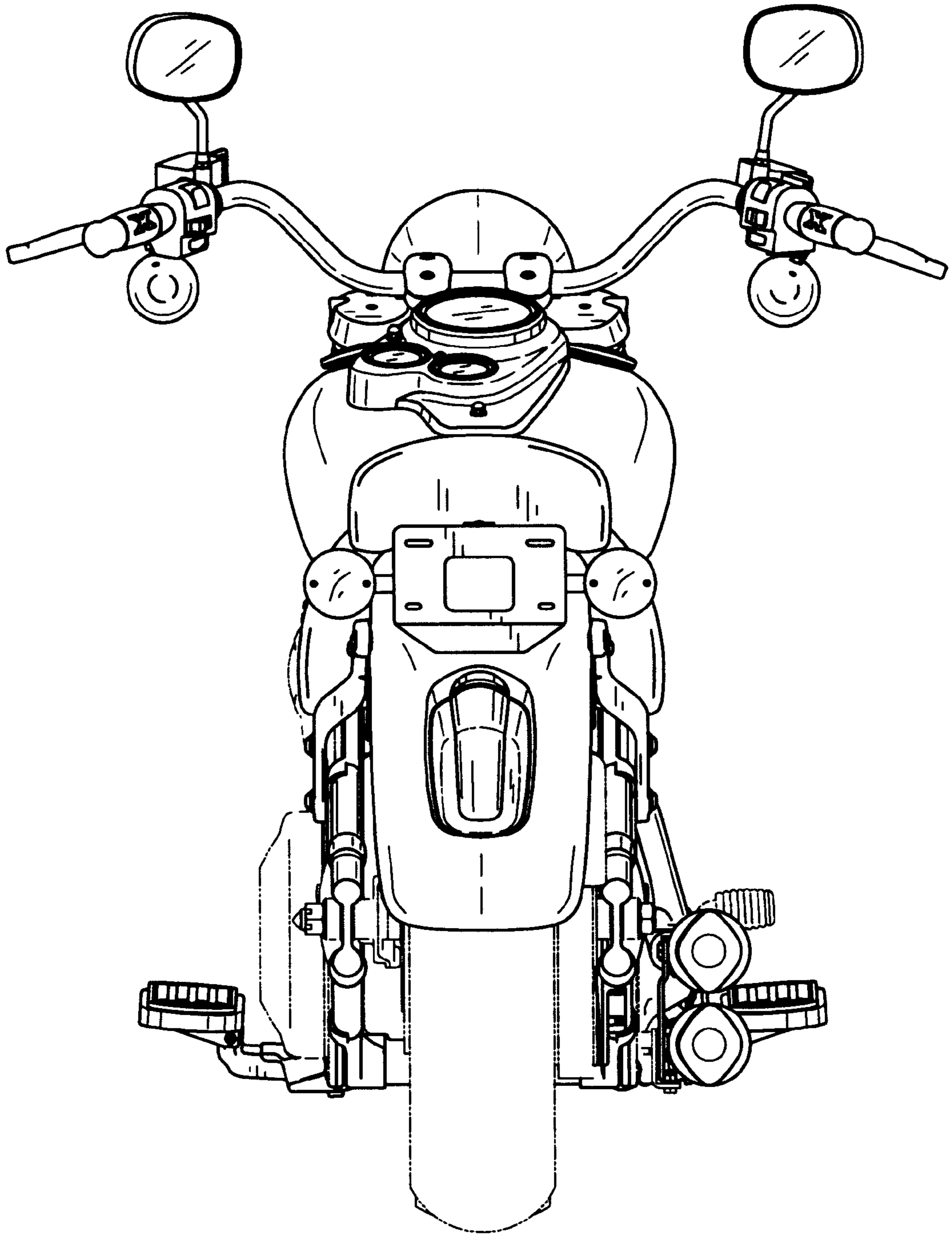

FIG. 5