



US00D416211S

United States Patent [19]

Arnoux et al.

[11] Patent Number: **Des. 416,211**

[45] Date of Patent: **** Nov. 9, 1999**

[54] **CLAMP-ON CURRENT PROBE**

[75] Inventors: **Daniel Arnoux; Axel Arnoux; Claude Genter**, all of Paris, France

[73] Assignee: **Societe Chauvin Arnoux**, Paris, France

[**] Term: **14 Years**

[21] Appl. No.: **29/093,413**

[22] Filed: **Sep. 10, 1998**

[30] **Foreign Application Priority Data**

Jun. 25, 1998 [FR] France 983784

[51] **LOC (6) Cl.** **10-04**

[52] **U.S. Cl.** **D10/79**

[58] **Field of Search** D10/79; 324/115, 324/116, 121 R, 127; 336/175, 212; 439/136, 145

[56] **References Cited**

U.S. PATENT DOCUMENTS

D. 398,547 9/1998 Arnoux et al. D10/79

Primary Examiner—Antoine Duval Davis
Attorney, Agent, or Firm—John L. Welch, Esq.

[57] **CLAIM**

The ornamental design for a clamp-on current probe, as shown.

DESCRIPTION

FIG. 1 is a right side elevational view of the clamp-on current probe according to our new design.

FIG. 2 is a left side elevational view thereof.

FIG. 3 is a bottom plan view thereof.

FIG. 4 is a top plan view thereof.

FIG. 5 is a front elevational view thereof, as seen from the right side of FIG. 1; and,

FIG. 6 is a rear elevational view thereof.

1 Claim, 5 Drawing Sheets

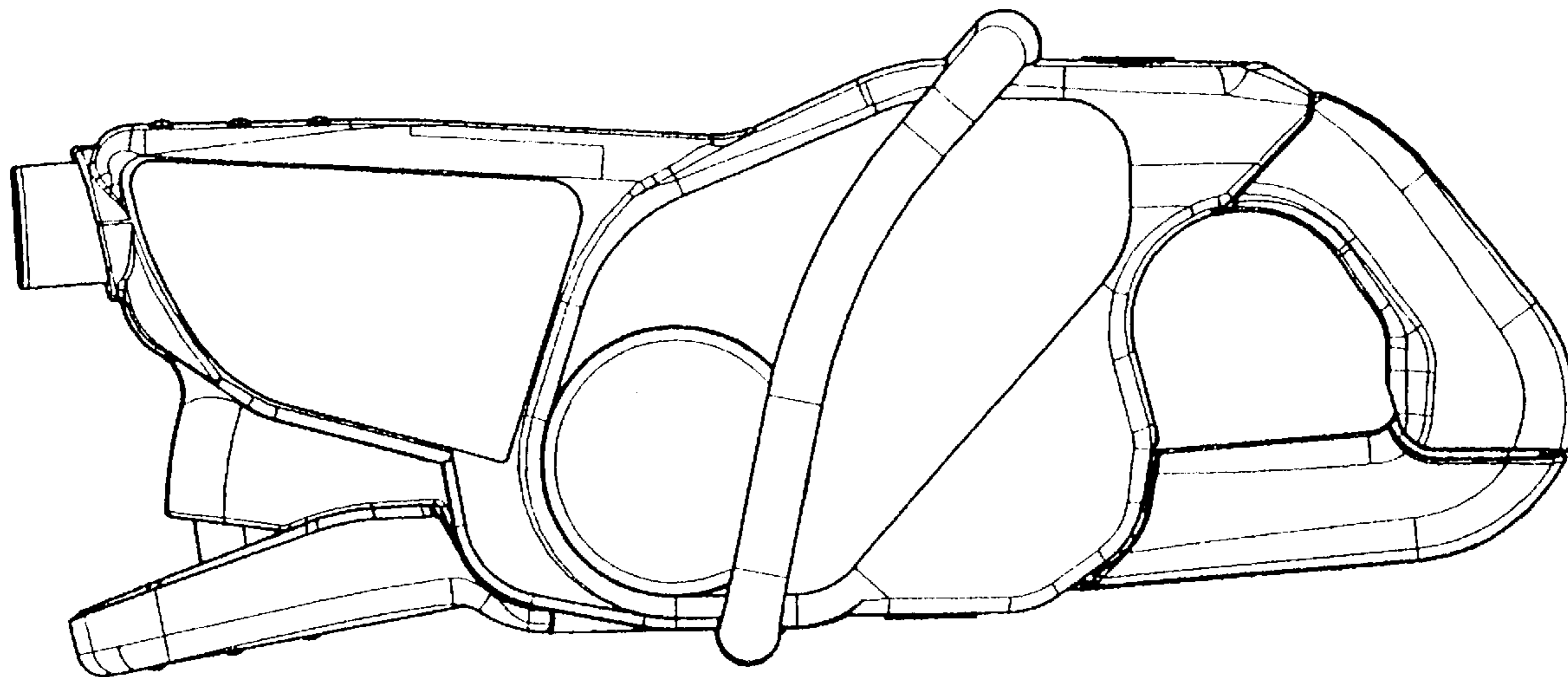

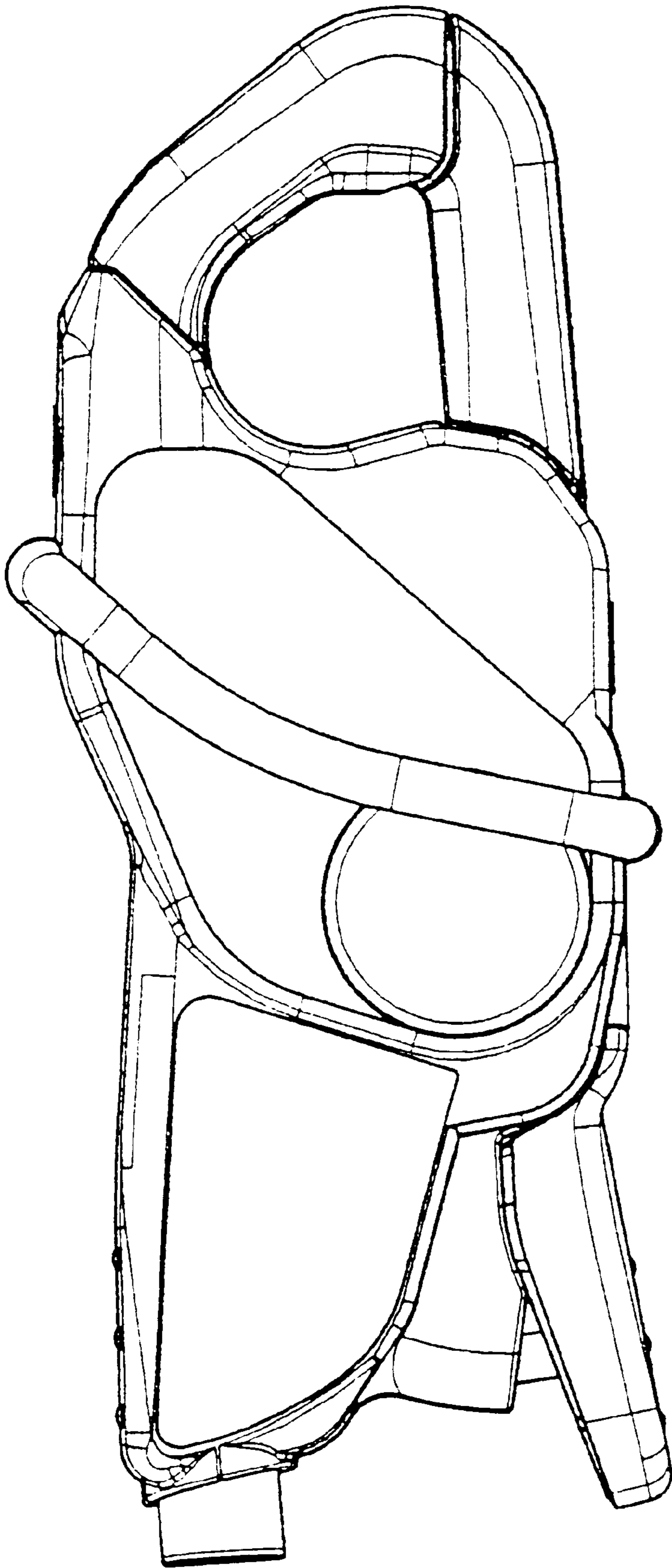

FIG. 1

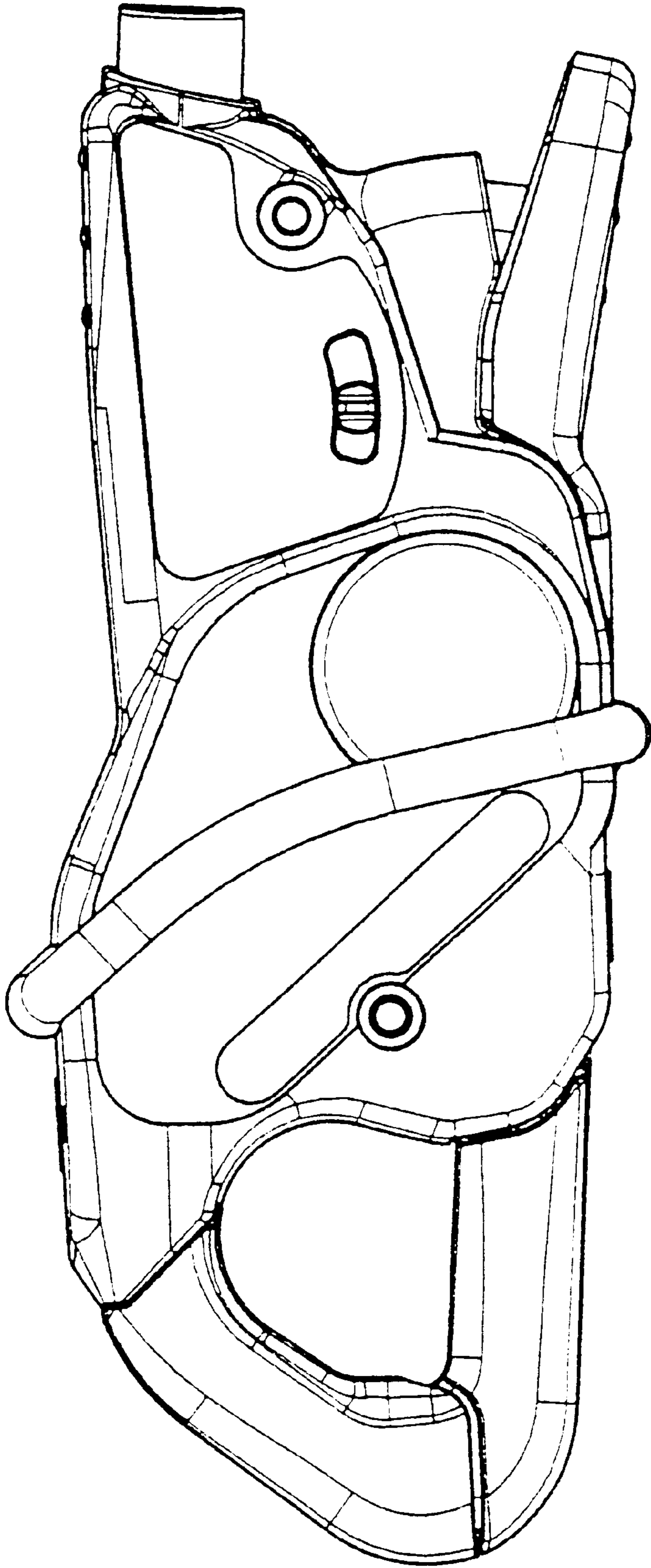

FIG. 2

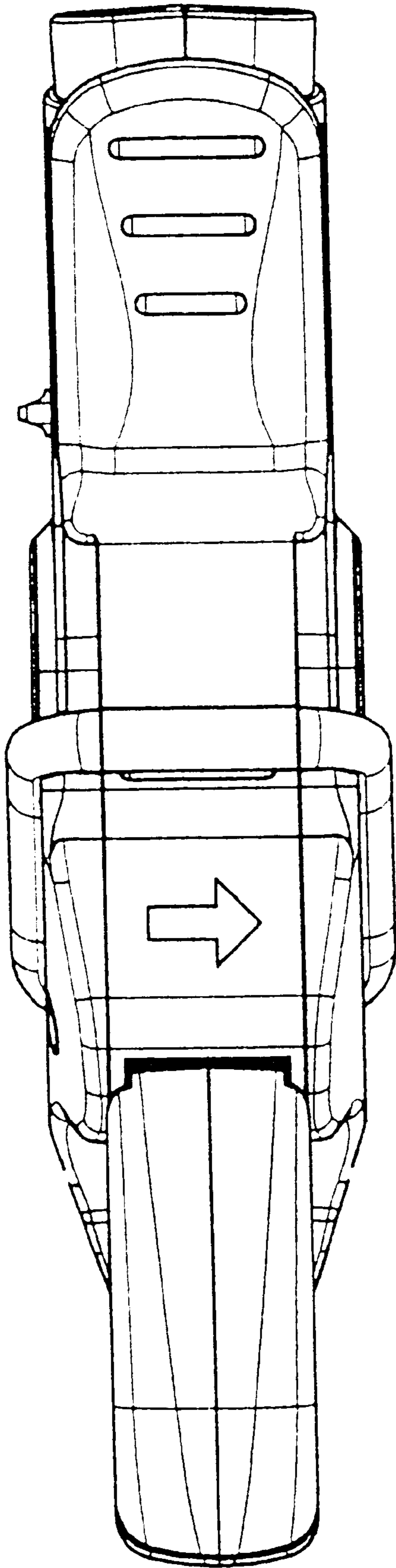

FIG. 3

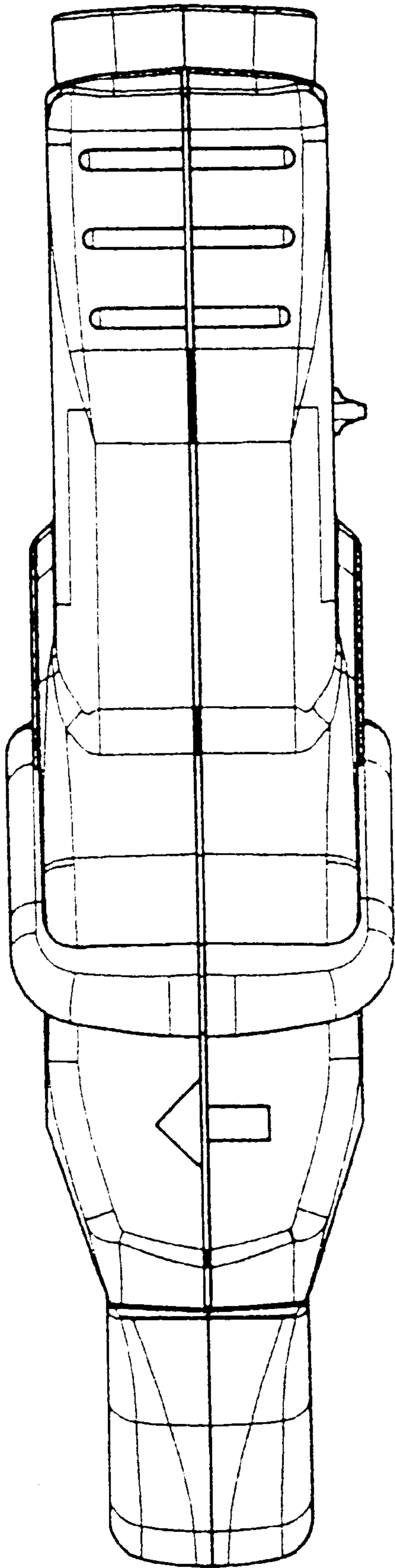

FIG. 4

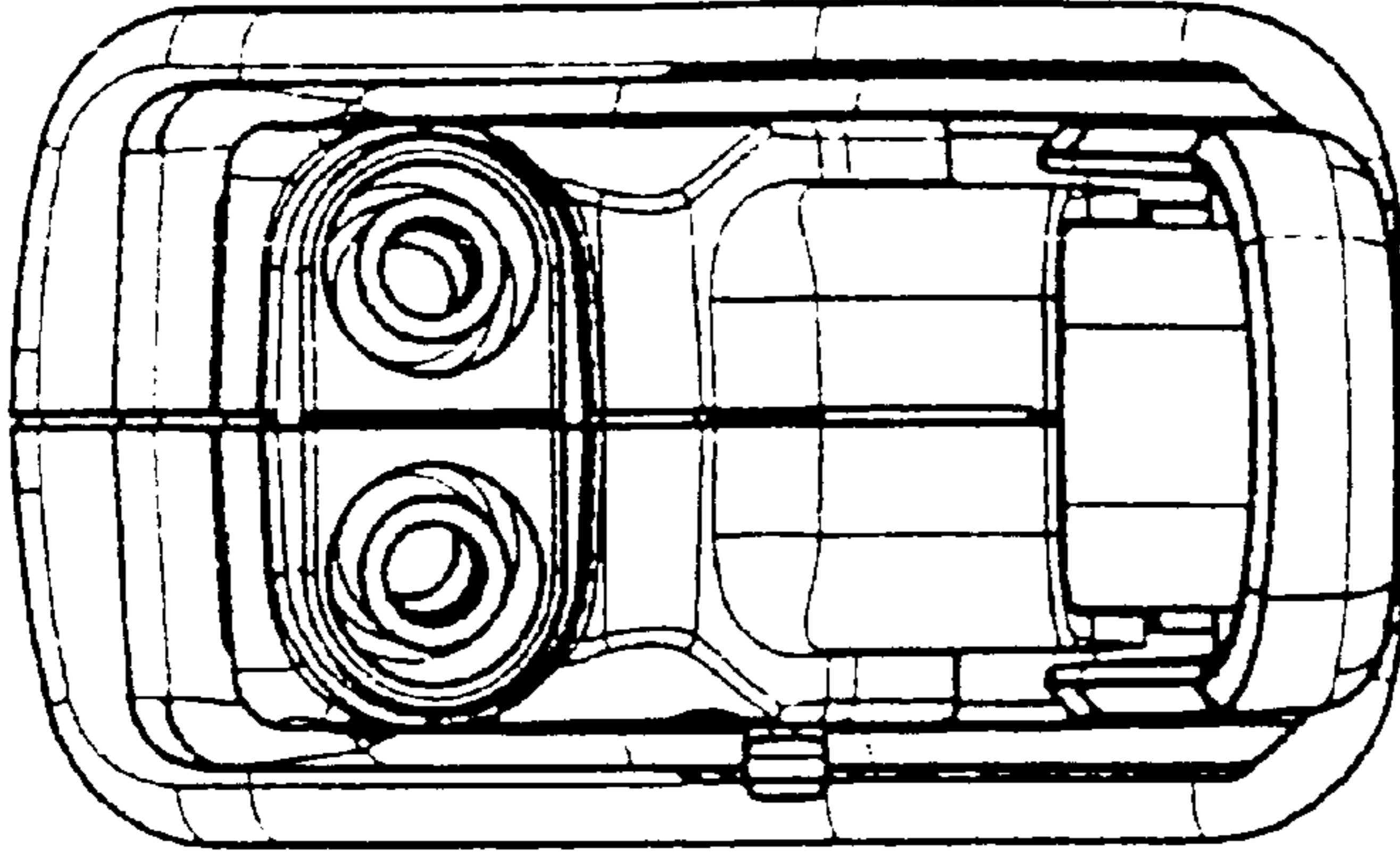

FIG. 6

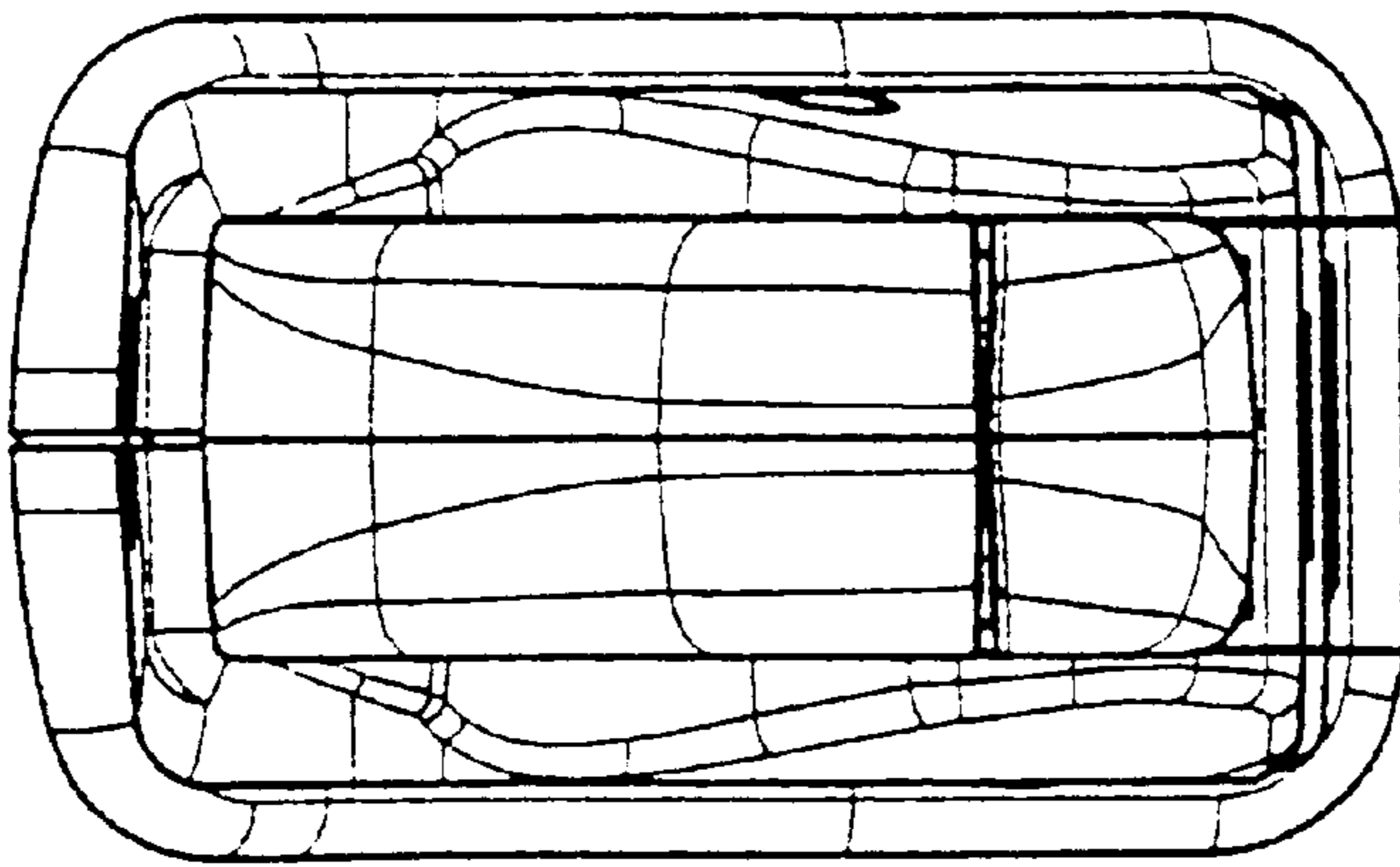

FIG. 5