



US00D416086S

# United States Patent [19]

[11] Patent Number: Des. 416,086

Parris et al.

[45] Date of Patent: \*\* Nov. 2, 1999

[54] **BLUNT CANNULA SPIKE ADAPTER**

[75] Inventors: **Wayne M. Parris**, Anaheim; **William A. Sperko**, Yorba Linda; **Peter N. Cassimatis**, San Clemente; **Martin V. Shabaz**, Santa Ana, all of Calif.

[73] Assignee: **B. Braun Medical, Inc.**, Irvine, Calif.

[\*\*] Term: **14 Years**

[21] Appl. No.: **29/077,709**

[22] Filed: **Oct. 9, 1997**

[51] **LOC (6) Cl.** ..... **24-02**

[52] **U.S. Cl.** ..... **D24/112; D24/130**

[58] **Field of Search** ..... D24/112, 130, 146, 147; 604/164, 165, 177, 158, 166, 170, 198, 263, 900, 102, 553

[56] **References Cited**

**U.S. PATENT DOCUMENTS**

D. 313,277 12/1990 Haining ..... D24/53

(List continued on next page.)

**FOREIGN PATENT DOCUMENTS**

0127781 12/1884 European Pat. Off. .

(List continued on next page.)

**OTHER PUBLICATIONS**

William R. Seebaugh et al., An Automated Device for Aseptically Aspirating Serum From Blood Collection Tubes, vol. BME-33, No. 6, Jun. 1986, pp. 609-616.

*Primary Examiner*—Stella Reid

*Assistant Examiner*—I Simmons

*Attorney, Agent, or Firm*—Christie, Parker & Hale, LLP

[57] **CLAIM**

The ornamental design for a blunt cannula spike adapter, as shown and described.

**DESCRIPTION**

FIG. 1 is a side perspective view of a blunt cannula spike adapter showing our new design; FIG. 2 is a top plan view thereof, the bottom plan view being identical thereto;

FIG. 3 is a right side elevational view thereof; FIG. 4 is a left side elevational view thereof; FIG. 5 is a rear elevational view thereof; FIG. 6 is a front elevational view thereof; FIG. 7 is a side perspective view of a second embodiment of a blunt cannula spike adapter showing our new design; FIG. 8 is a top plan view thereof, the bottom plan view being identical thereto; FIG. 9 is a right side elevational view thereof; FIG. 10 is a left side elevational view thereof; FIG. 11 is a rear elevational view thereof; FIG. 12 is a front elevational view thereof; FIG. 13 is a side perspective view of the blunt cannula spike adapter as seen in FIG. 1, with the spike sheath removed; FIG. 14 is a top plan view thereof, the bottom plan view being identical thereto; FIG. 15 is a right side elevational view thereof; FIG. 16 is a left side elevational view thereof; FIG. 17 is a rear elevational view thereof; FIG. 18 is a front elevational view thereof; FIG. 19 is a side perspective view of the second embodiment as seen in FIG. 7, with the spike sheath removed; FIG. 20 is a top plan view thereof, the bottom plan view being identical thereto; FIG. 21 is a right side elevational view thereof; FIG. 22 is a left side elevational view thereof; FIG. 23 is a rear elevational view thereof; FIG. 24 is a front elevational view thereof; FIG. 25 is a side perspective view of the blunt cannula spike adapter as seen in FIG. 1, with the spike sheath and blunt cannula removed; FIG. 26 is a top plan view thereof, the bottom plan view being identical thereto; FIG. 27 is a right side elevational view thereof; FIG. 28 is a left side elevational view thereof; FIG. 29 is a rear elevational view thereof; FIG. 30 is a front elevational view thereof; FIG. 31 is a side perspective view of the second embodiment as seen in FIG. 7, with the spike sheath and blunt cannula removed; FIG. 32 is a top plan view thereof, the bottom plan view being identical thereto; FIG. 33 is a right side elevational view thereof; FIG. 34 is a left side elevational view thereof; FIG. 35 is a rear elevational view thereof; and, FIG. 36 is a front elevational view thereof.

**1 Claim, 24 Drawing Sheets**

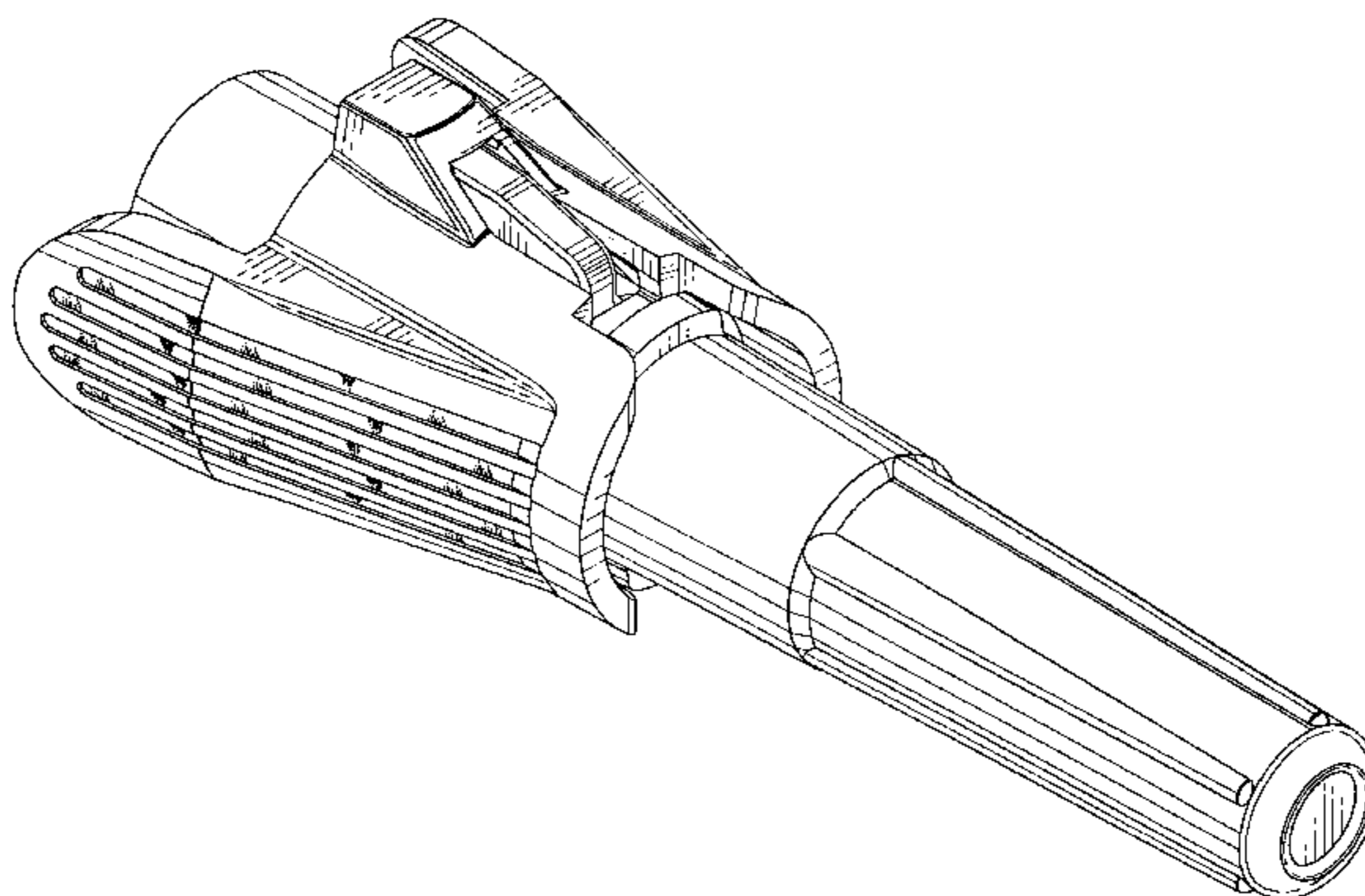

## U.S. PATENT DOCUMENTS

D. 314,622	2/1991	Andersson et al. ....	D24/112	4,702,735	10/1987	Luther et al. ....	604/161
D. 321,252	10/1991	Jepson et al. ....	D24/112	4,747,836	5/1988	Luther ....	604/198
D. 378,405	3/1997	Musgrave et al. ....	D24/146 X	4,759,756	7/1988	Furman et al. ....	D24/129
D. 399,559	10/1998	Molina ....	D24/112	4,762,516	8/1988	Luther et al. ....	604/164
2,102,704	12/1937	Hein ....	128/218	4,790,817	12/1988	Luther ....	604/53
2,559,474	7/1951	Son ....	128/215	4,804,366	2/1989	Zdeb et al. ....	604/85
2,564,804	8/1951	Everett ....	128/221	4,826,500	5/1989	Rautsola ....	604/411
2,746,455	5/1956	Abel ....	128/221	4,832,696	5/1989	Luther et al. ....	604/164
2,770,236	11/1956	Utley et al. ....	128/221	4,834,152	5/1989	Howson et al. ....	141/286
2,817,372	12/1957	Barr, Sr. et al. ....	141/288	4,838,871	6/1989	Luther ....	604/192
2,911,972	11/1959	Elinger ....	128/216	4,842,591	6/1989	Luther ....	604/283
2,929,510	3/1960	Penn ....	211/60	4,861,341	8/1989	Woodburn ....	604/175
2,954,768	10/1960	Hamilton ....	128/221	4,869,717	9/1989	Adair ....	604/51
2,989,053	6/1961	Hamilton ....	128/221	4,892,518	1/1990	Cupp et al. ....	604/93
3,030,953	4/1962	Koehn ....	128/214	4,909,791	3/1990	Norelli ....	604/192
3,526,340	9/1970	Heinz ....	222/80	4,935,020	6/1990	Brodén ....	604/411
3,645,268	2/1972	Capote ....	128/347	4,950,252	8/1990	Luther et al. ....	604/198
3,826,260	7/1974	Killinger ....	128/272	4,964,854	10/1990	Luther ....	604/166
3,831,814	8/1974	Bulter ....	222/81	4,969,883	11/1990	Gilbert et al. ....	604/414
3,995,630	12/1976	van de Veerdonk ....	128/218 DA	4,994,029	2/1991	Rohrbough ....	604/88
4,096,860	6/1978	McLaughlin ....	128/214.4	5,053,014	10/1991	Van Heugten ....	604/167
4,123,091	10/1978	Cosentino et al. ....	285/39	5,071,413	12/1991	Utterberg ....	604/283
4,153,057	5/1979	Köbel ....	128/272.1	5,098,394	3/1992	Luther ....	604/167
4,244,364	1/1981	Grushkin ....	128/214	5,112,315	5/1992	Gloyer et al. ....	604/195
4,328,802	5/1982	Curley et al. ....	128/272.1	5,122,120	6/1992	Wallace ....	604/164
4,369,781	1/1983	Gilson et al. ....	128/214	5,135,513	8/1992	Meyer et al. ....	604/240
4,377,165	3/1983	Luther et al. ....	128/214.4	5,167,642	12/1992	Fowles ....	604/263
4,410,321	10/1983	Pearson et al. ....	604/56	5,211,638	5/1993	Dudar et al. ....	604/283
4,449,973	5/1984	Luther ....	604/161	5,312,345	5/1994	Cole ....	604/110
4,542,749	9/1985	Caselgrandi et al. ....	128/752	5,368,607	11/1994	Freitas ....	606/172
4,559,043	12/1985	Whitehouse et al. ....	604/201	5,411,499	5/1995	Dudar et al. ....	604/411
4,569,675	2/1986	Prosl et al. ....	604/175	5,454,409	10/1995	McAffer et al. ....	141/329
4,573,967	3/1986	Hargrove et al. ....	604/56	5,470,327	11/1995	Helgren et al. ....	604/411
4,573,981	3/1986	McFarlane ....	604/263	5,547,471	8/1996	Thompson et al. ....	604/87
4,573,993	3/1986	Hoag et al. ....	604/411	5,584,819	12/1996	Kopfer ....	604/239
4,589,879	5/1986	Pearson ....	604/411	5,810,792	9/1998	Fangrow, Jr. et al. ....	604/533
4,610,671	9/1986	Luther ....	604/168				
4,624,667	11/1986	Rutnarak ....	604/414				
4,632,671	12/1986	Dalton ....	604/174				
4,638,809	1/1987	Kuperus ....	128/653				
4,650,475	3/1987	Smith et al. ....	604/189				
4,668,221	5/1987	Luther ....	604/164				

## FOREIGN PATENT DOCUMENTS

0395758	11/1990	European Pat. Off. .
1171578	1/1959	France .
486715	9/1937	United Kingdom .
843744	8/1960	United Kingdom .
927020	5/1963	United Kingdom .

FIG. 1

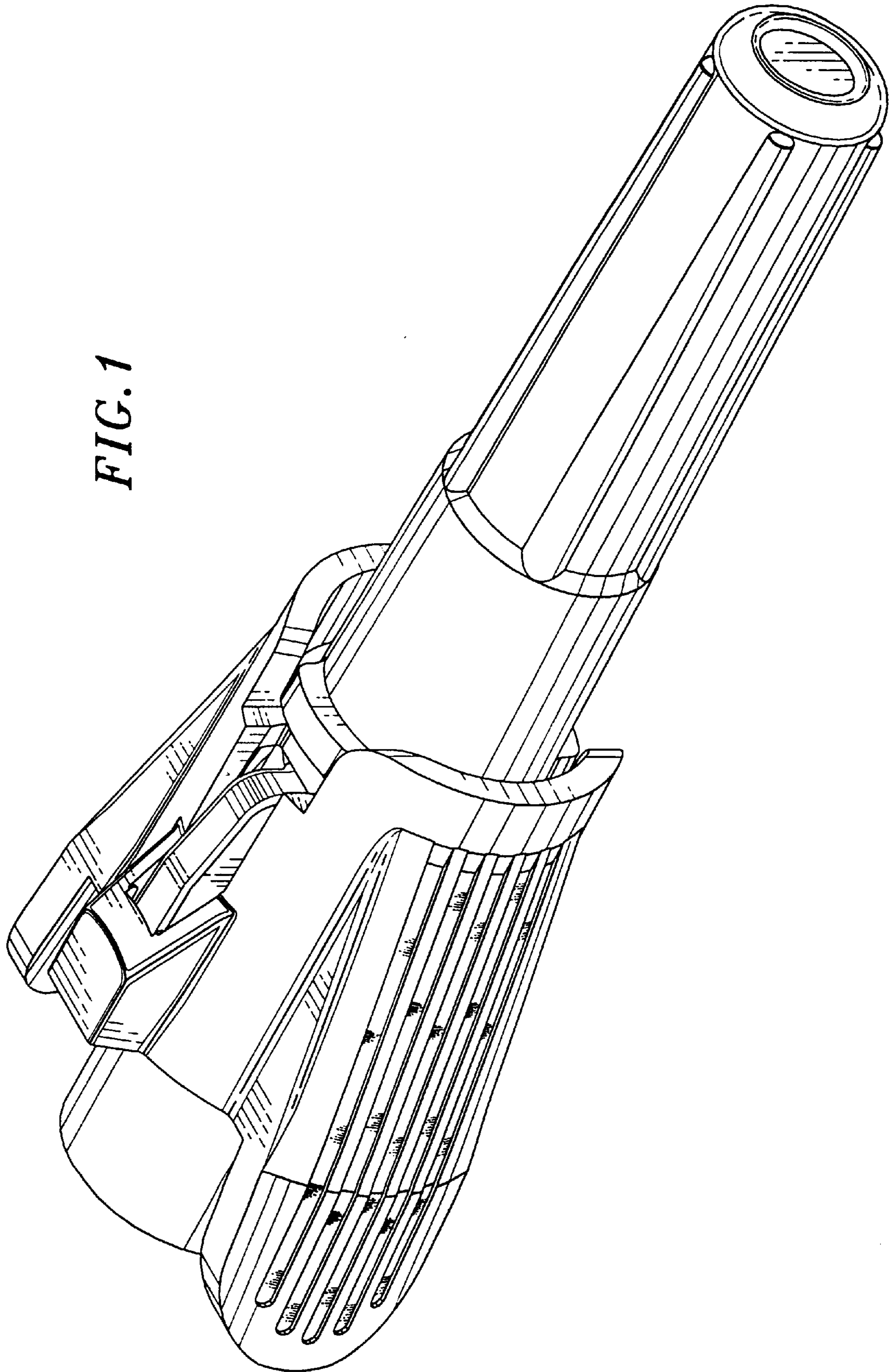

FIG. 2

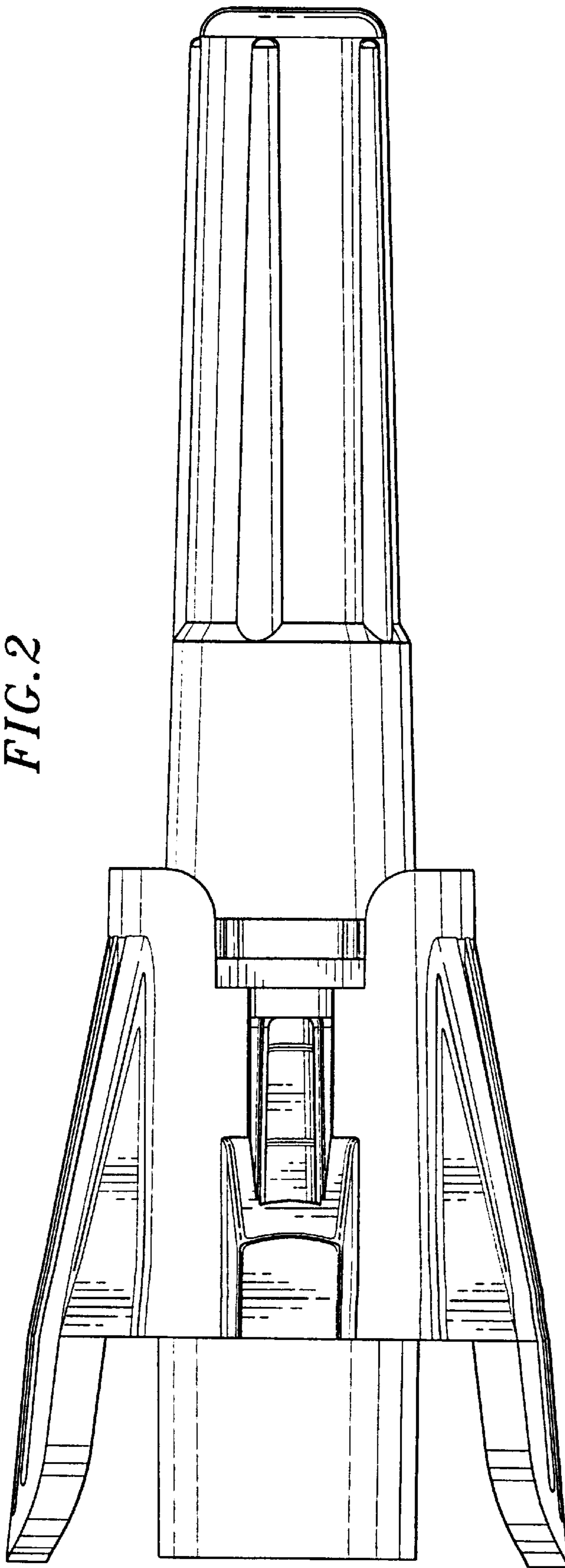

FIG. 3

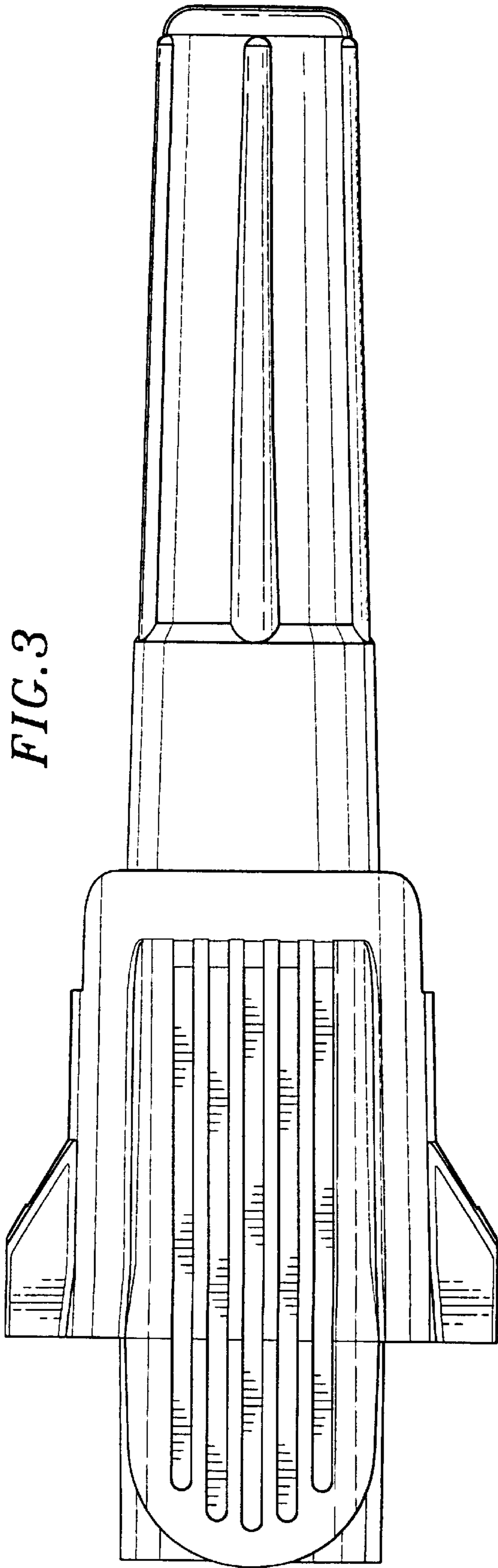
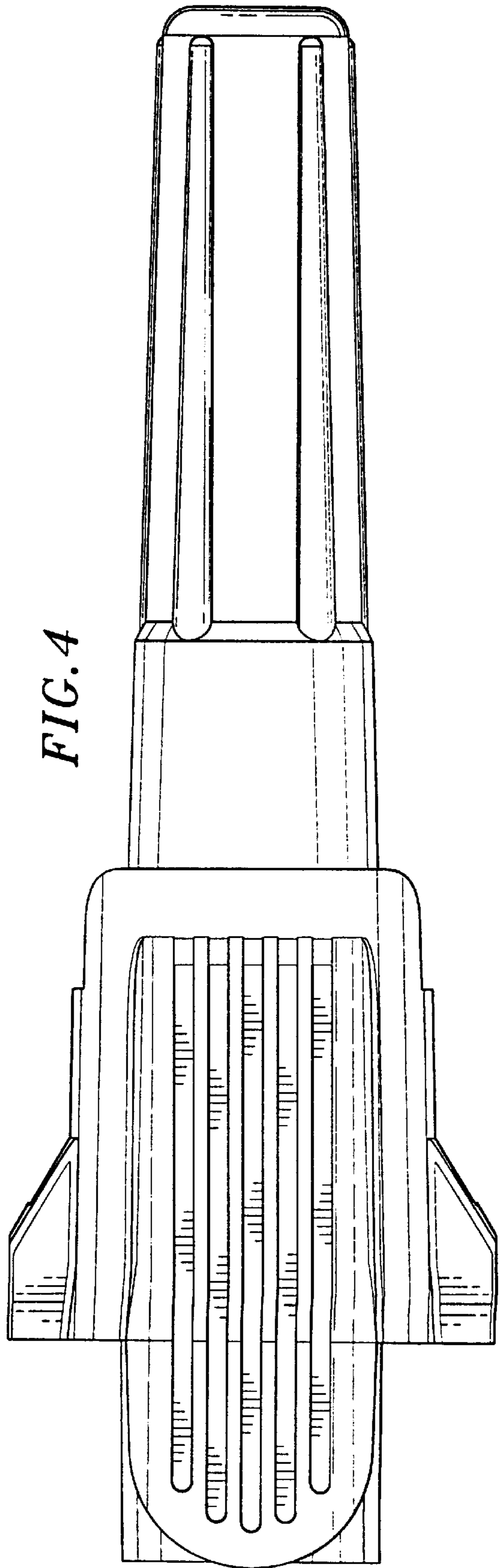
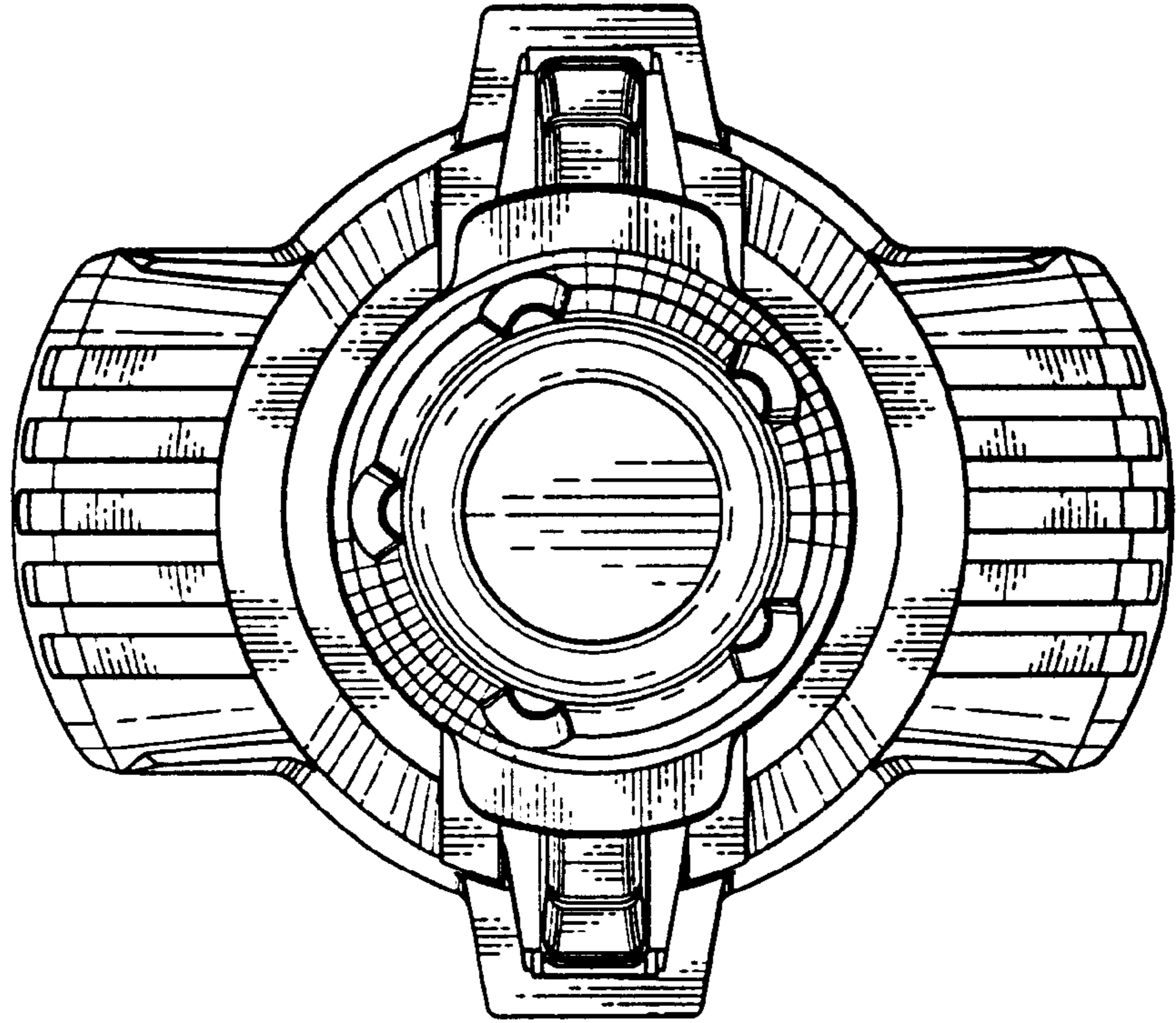

FIG. 4



*FIG. 6*



*FIG. 5*

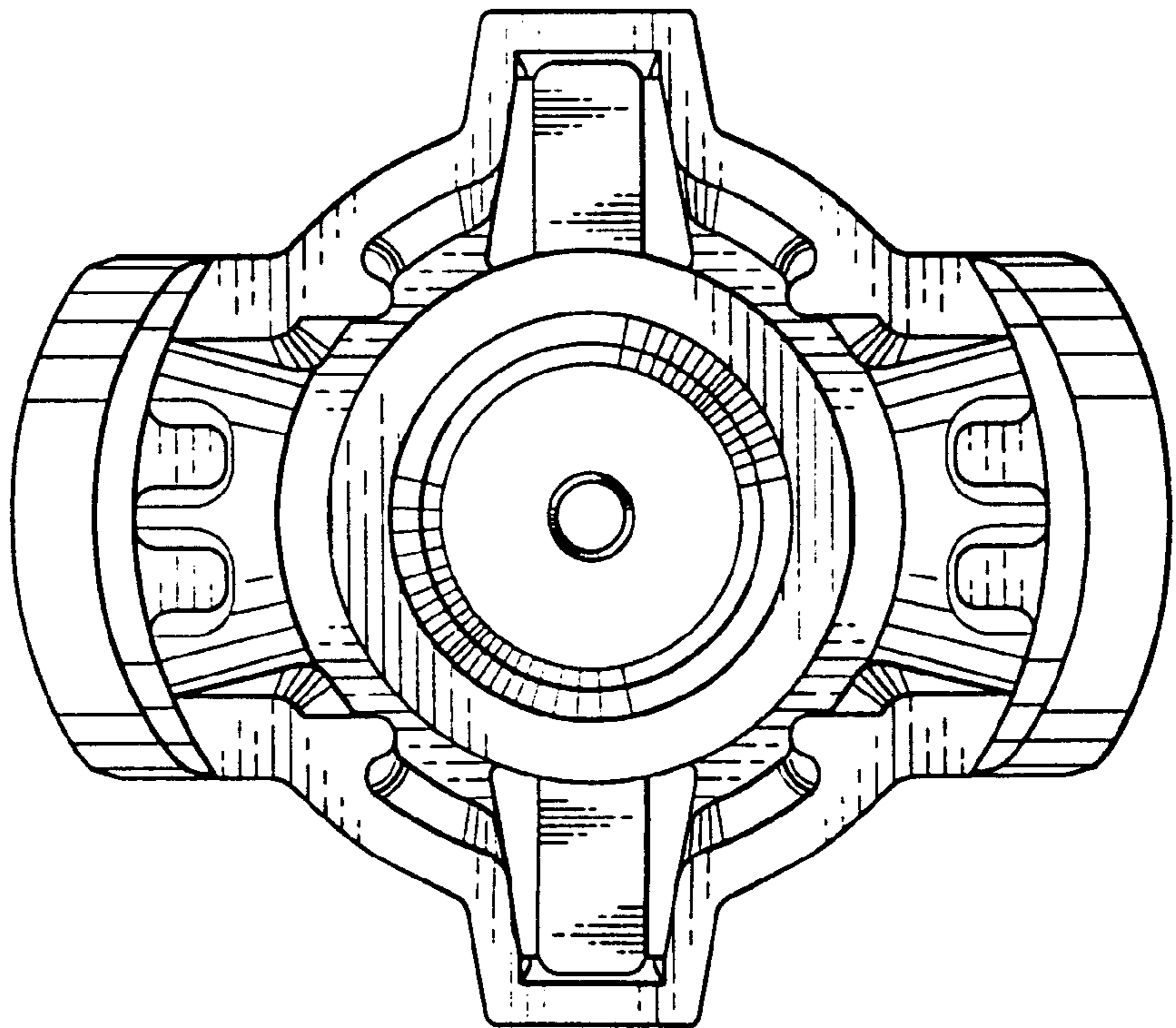
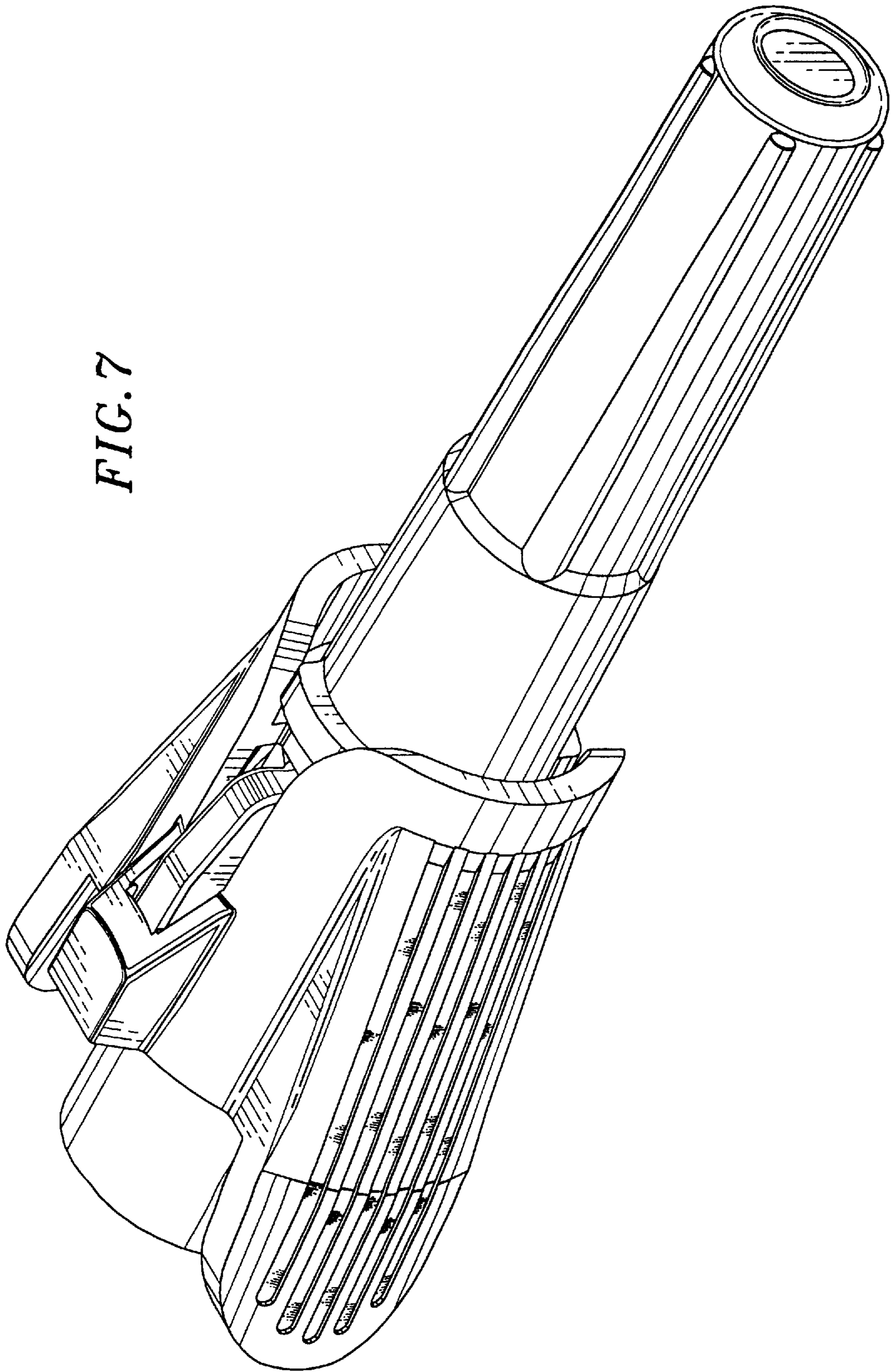

FIG. 7



*FIG. 8*

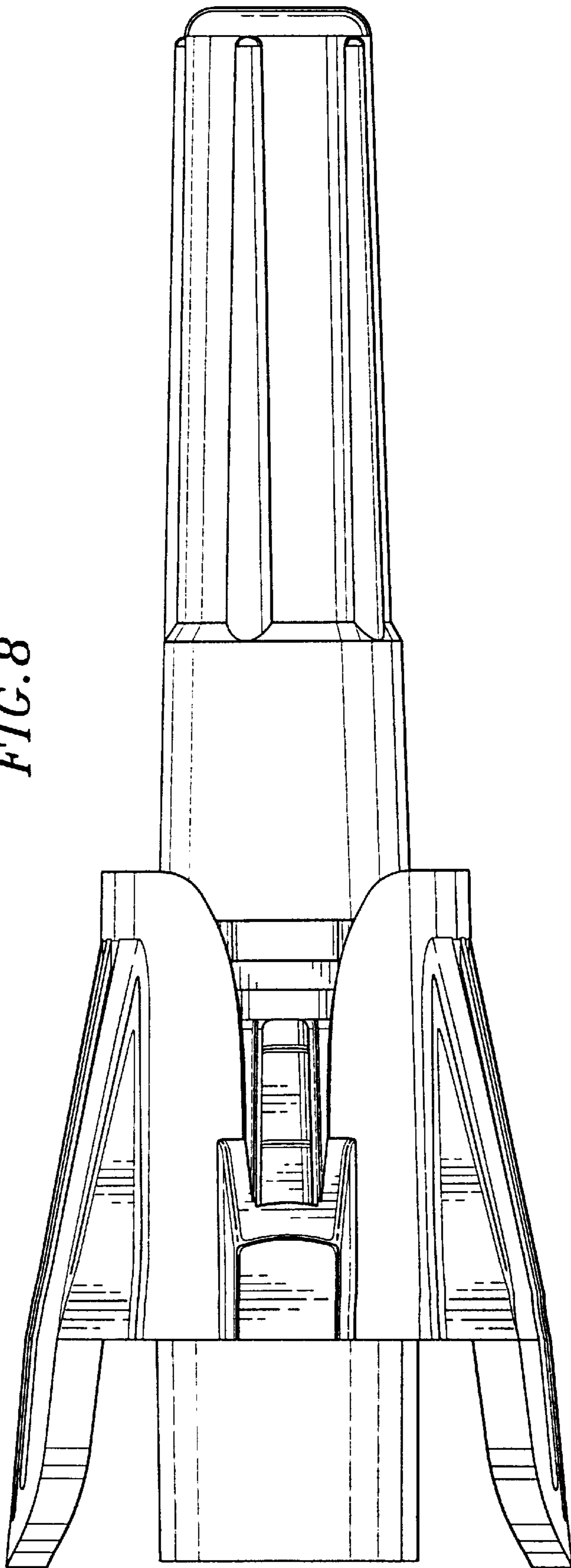



FIG. 9

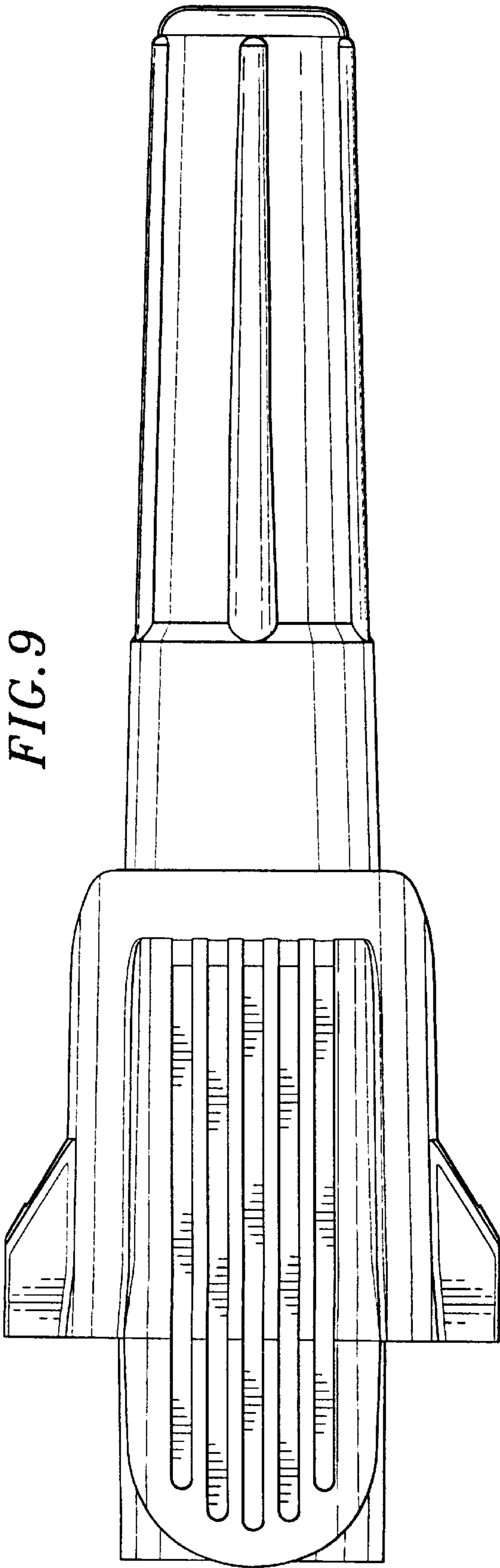
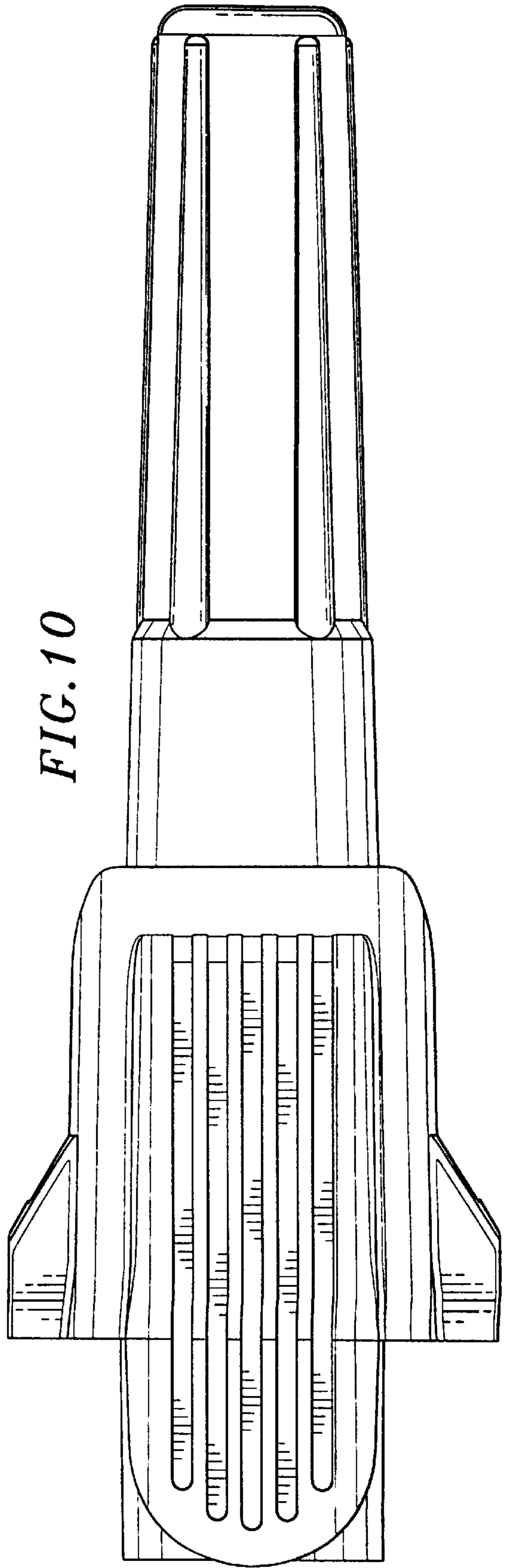
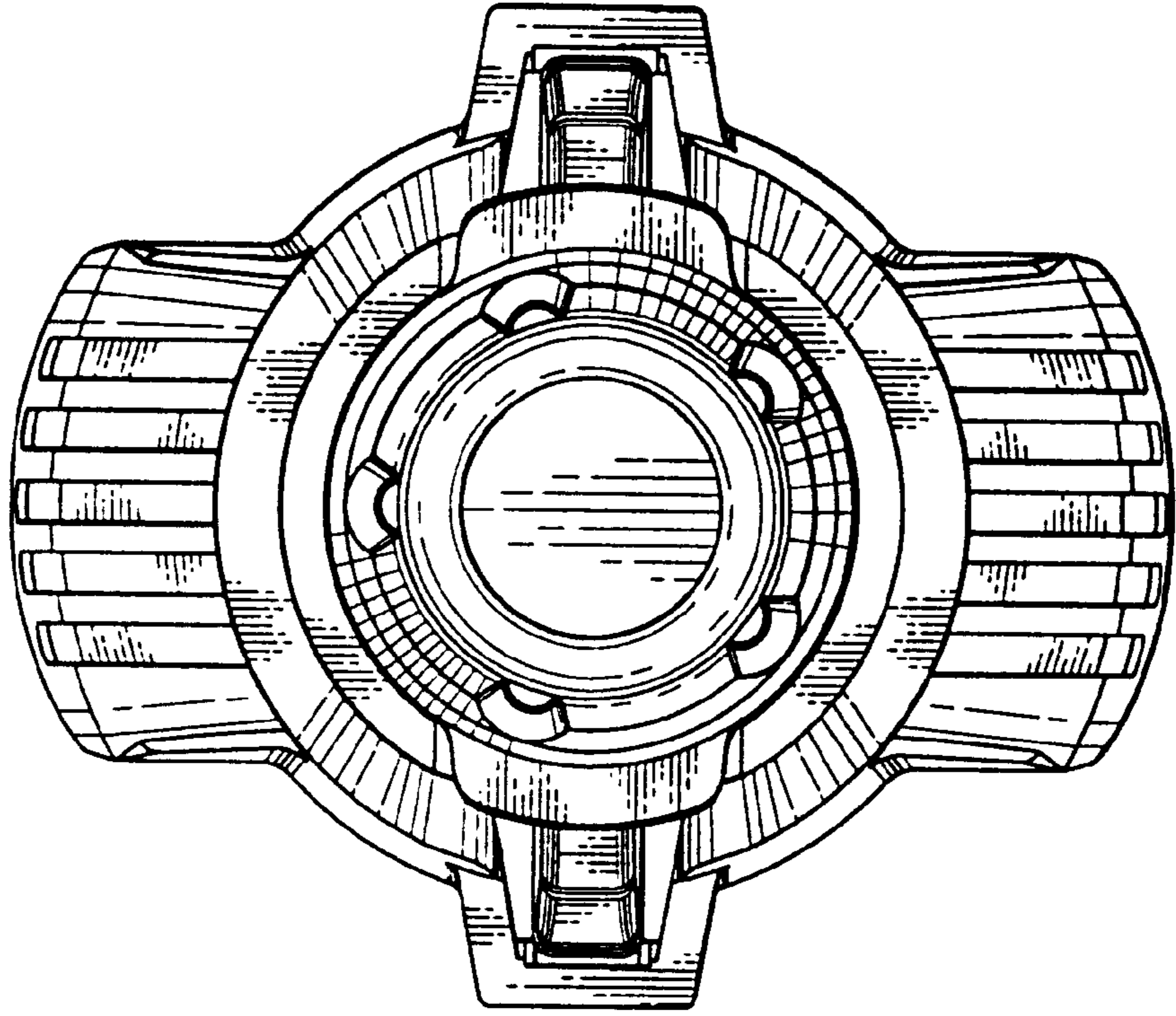

FIG. 10



*FIG. 12*



*FIG. 11*

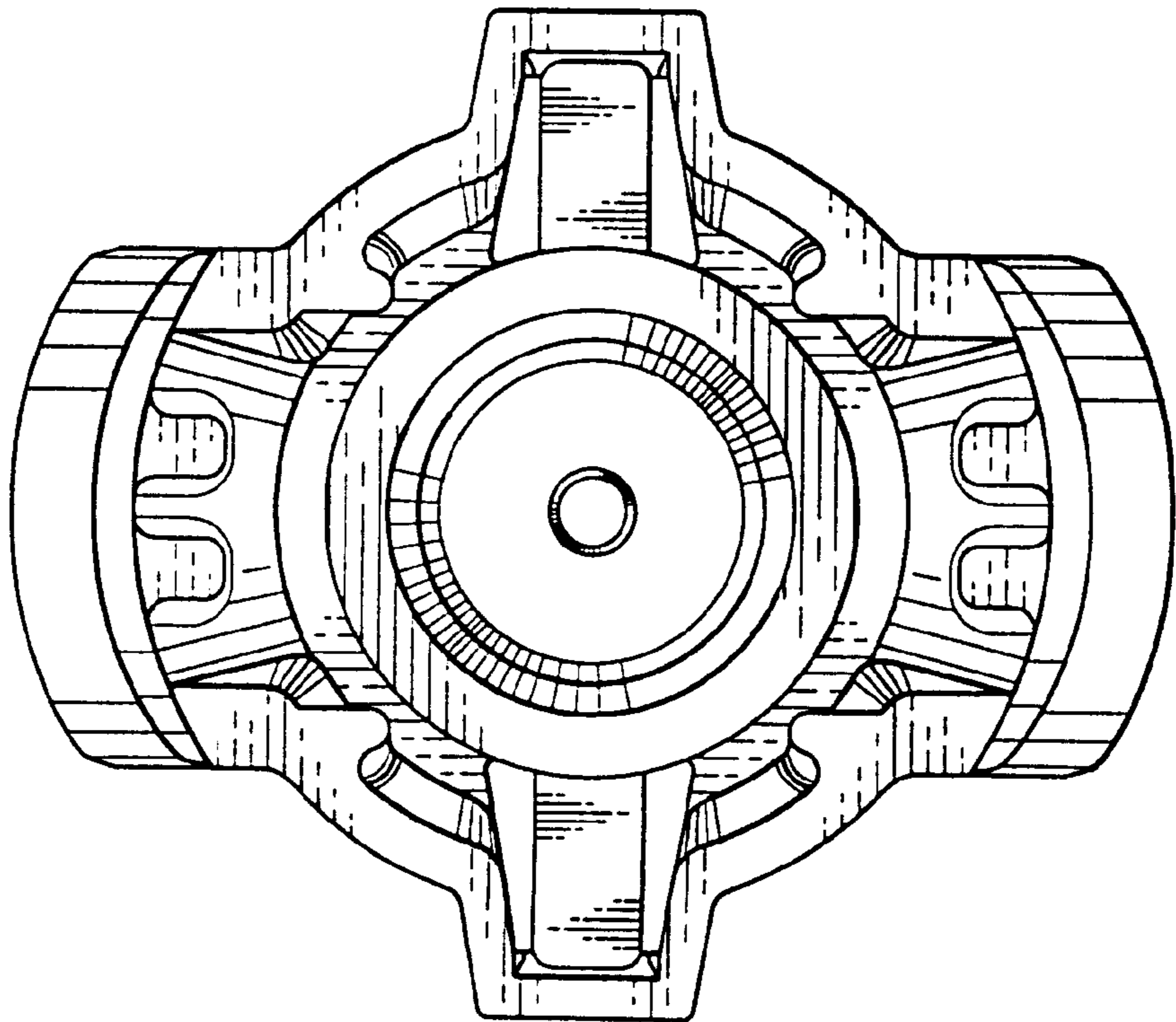
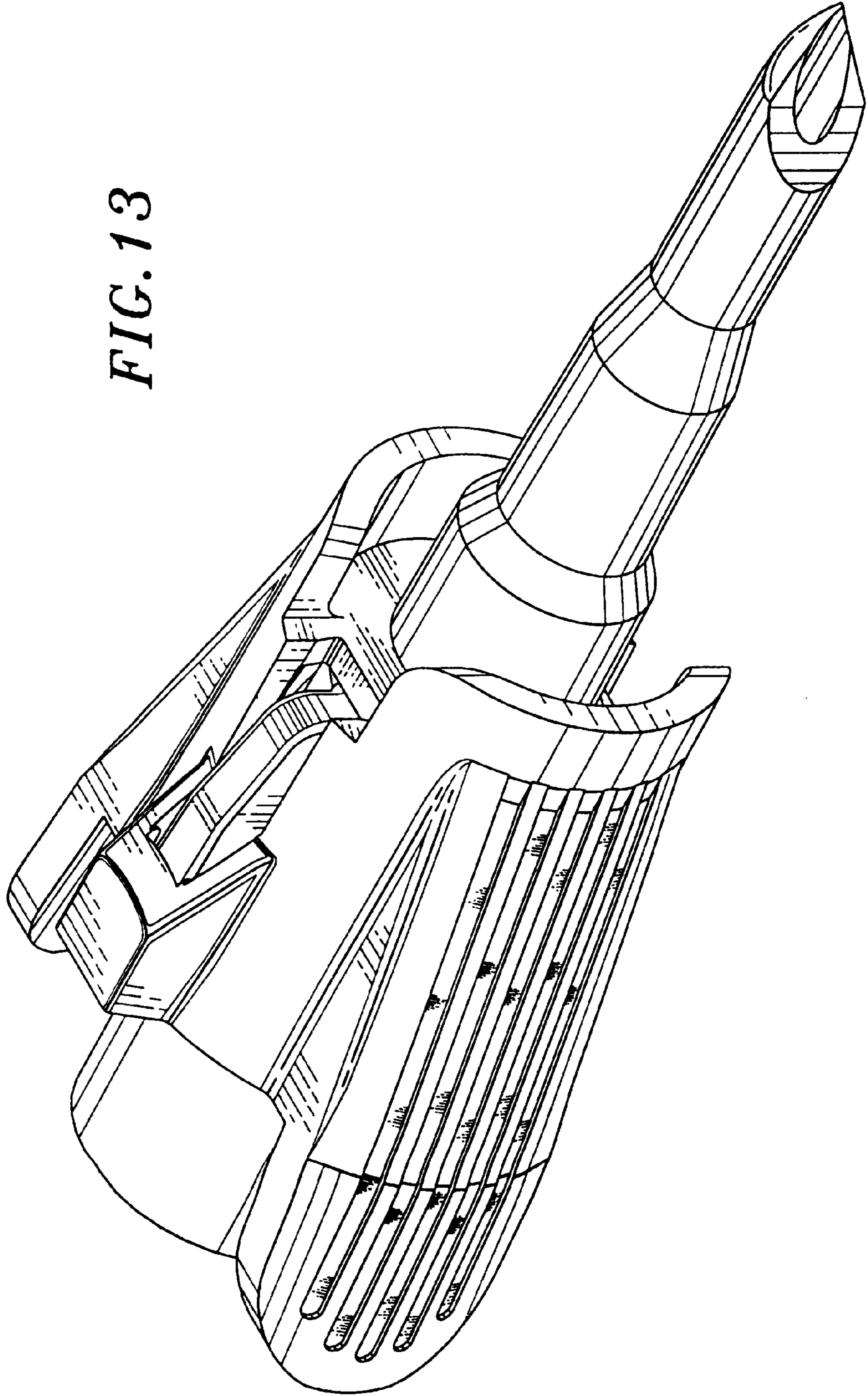
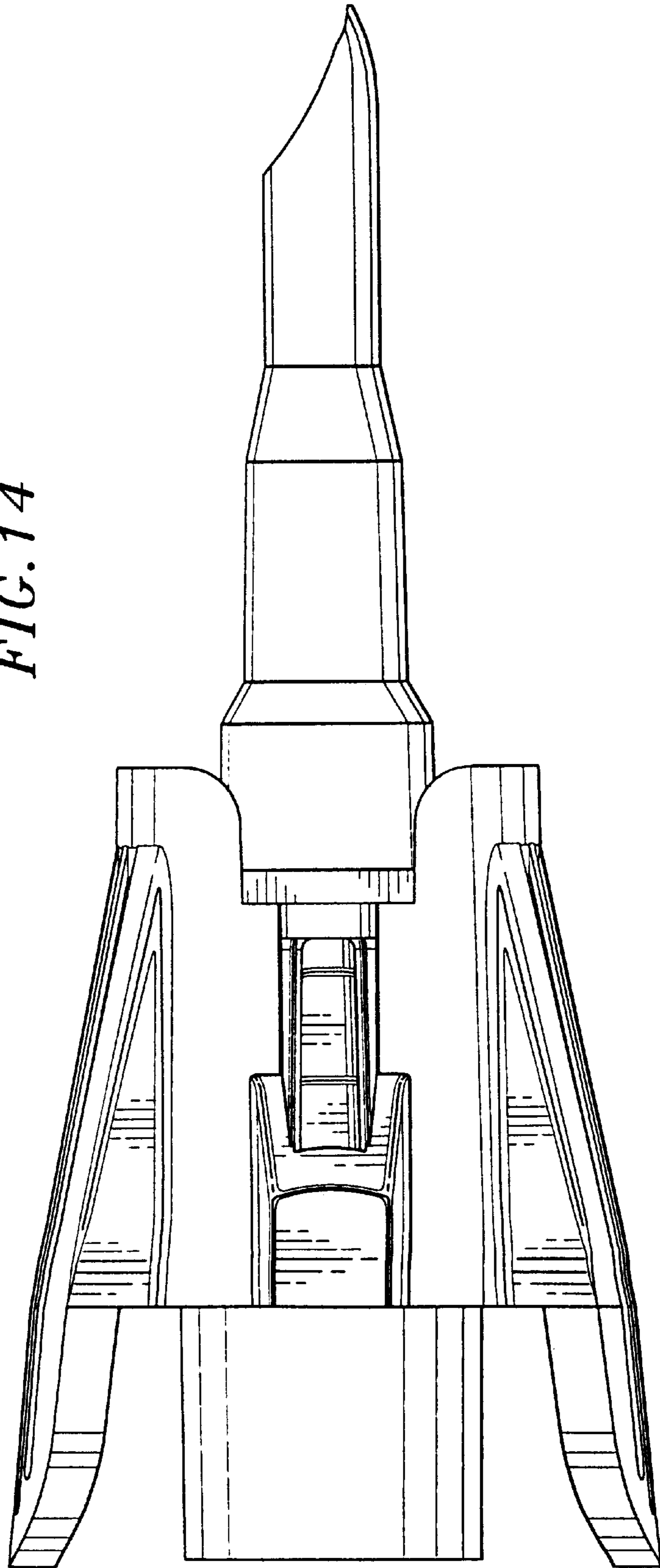
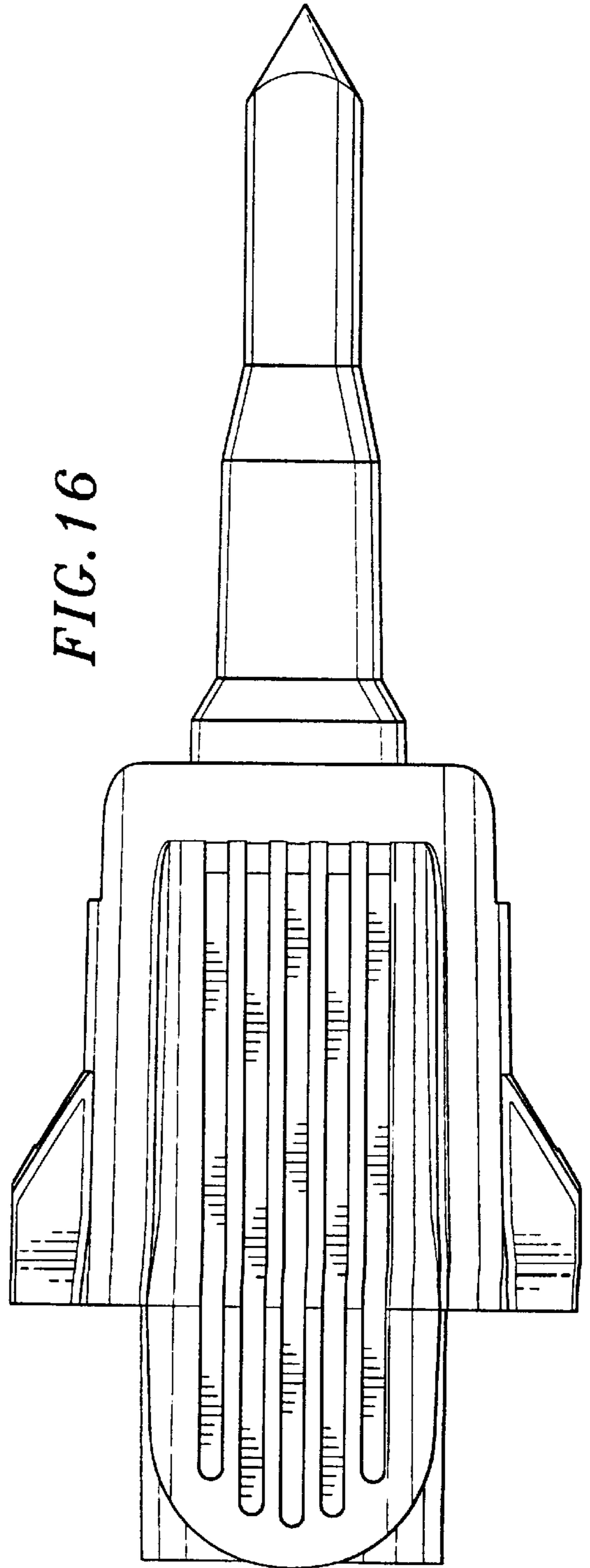
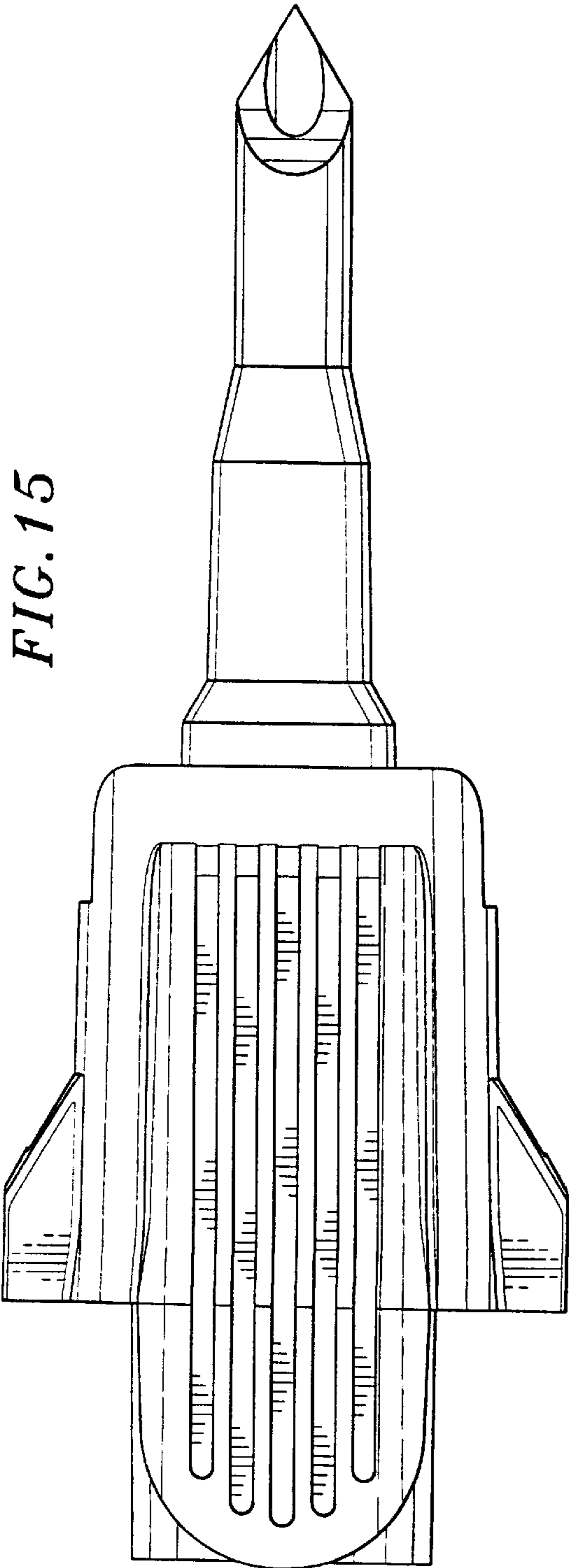

FIG. 13

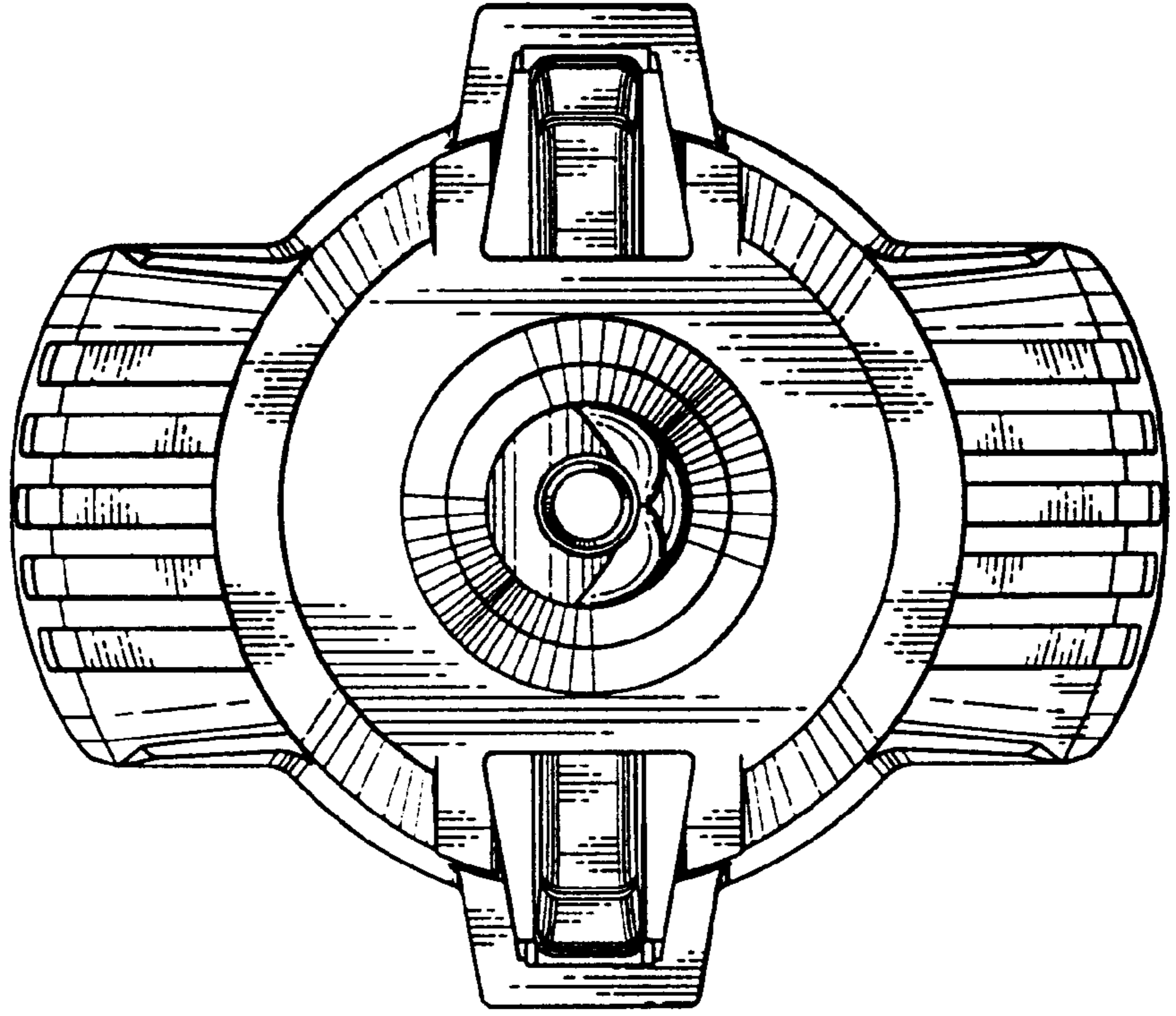

*FIG. 14*





*FIG. 18*



*FIG. 17*

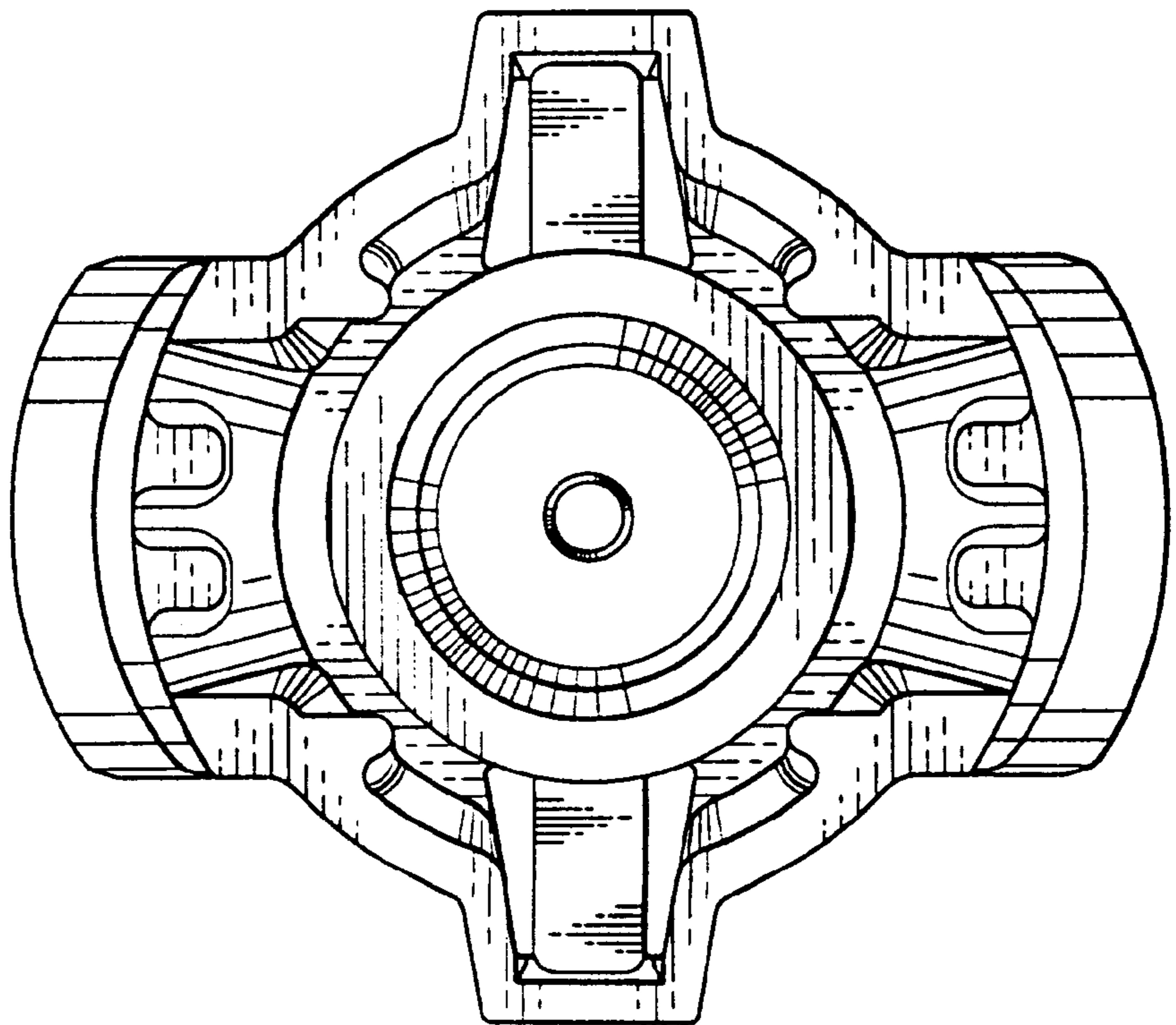

FIG. 19

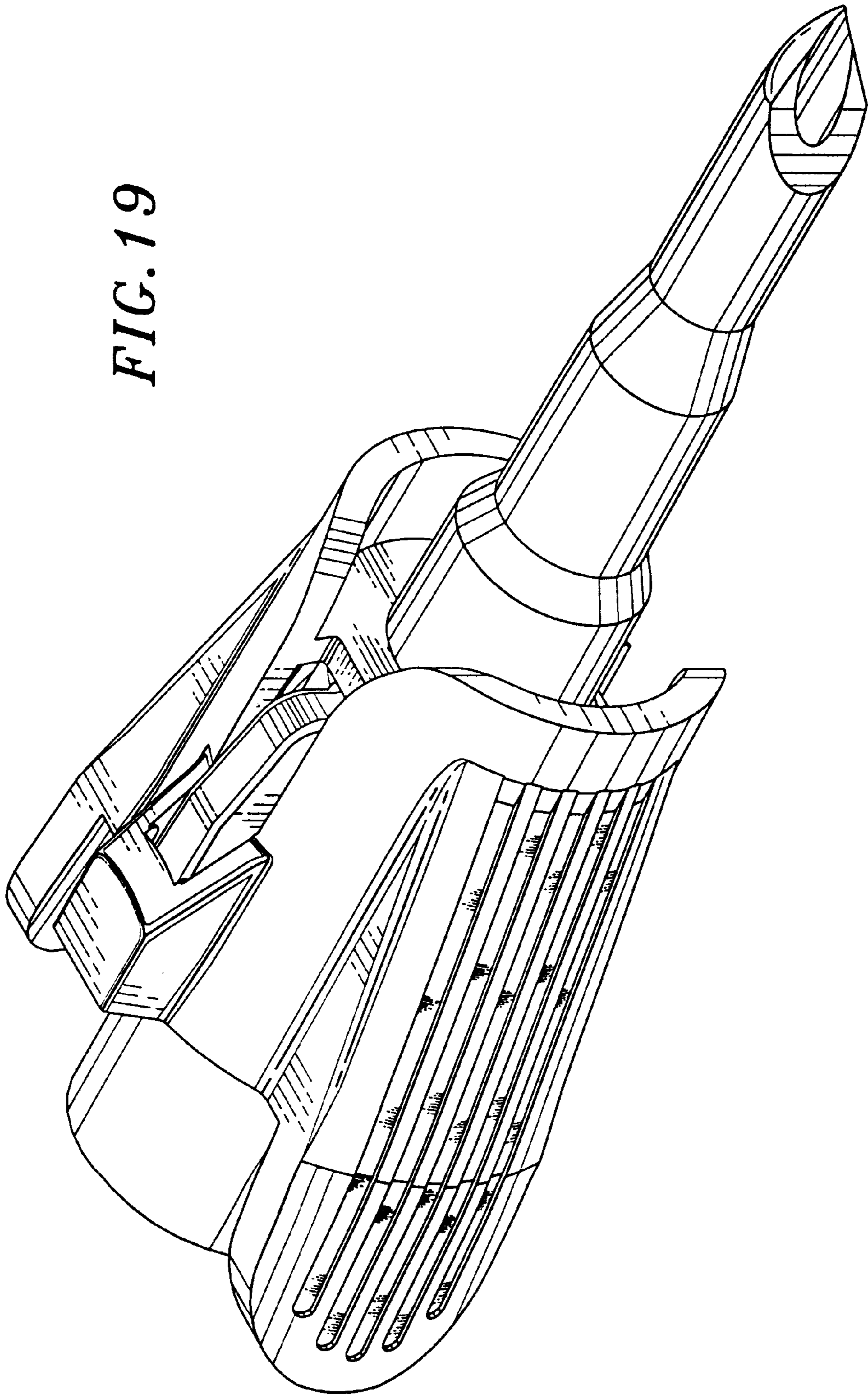
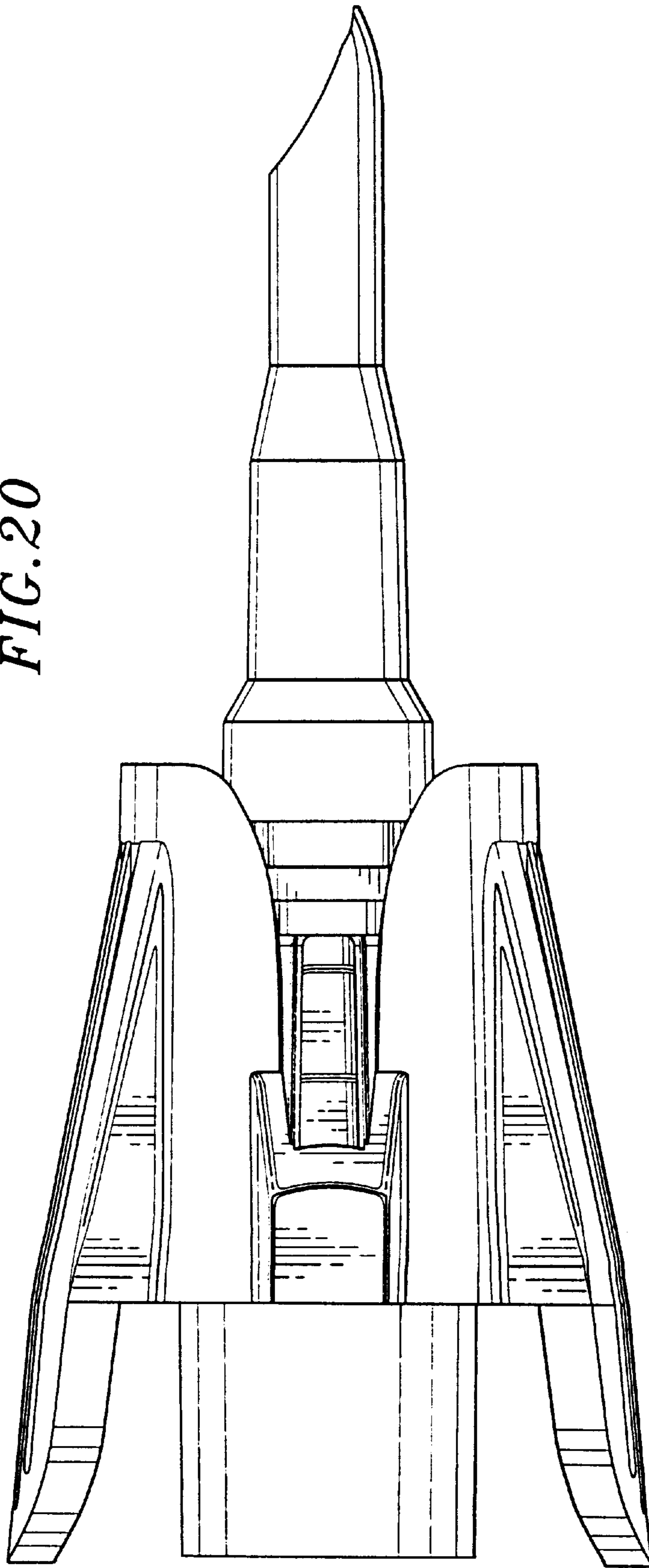
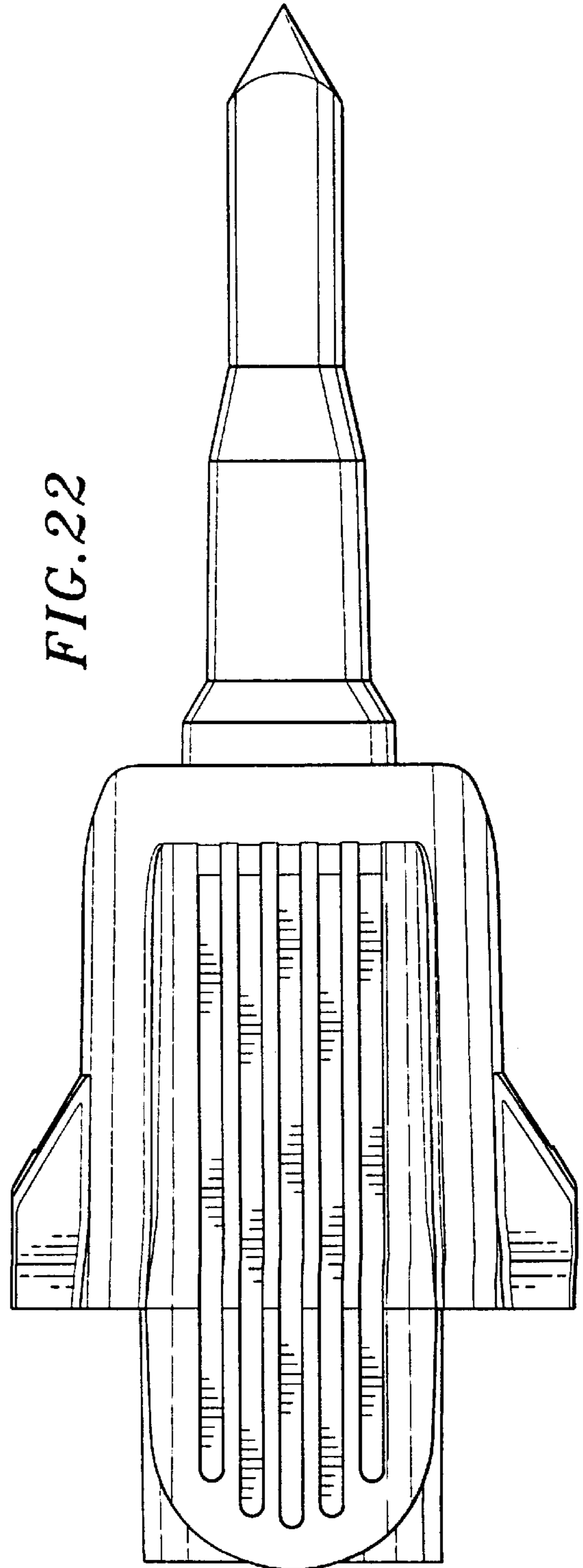
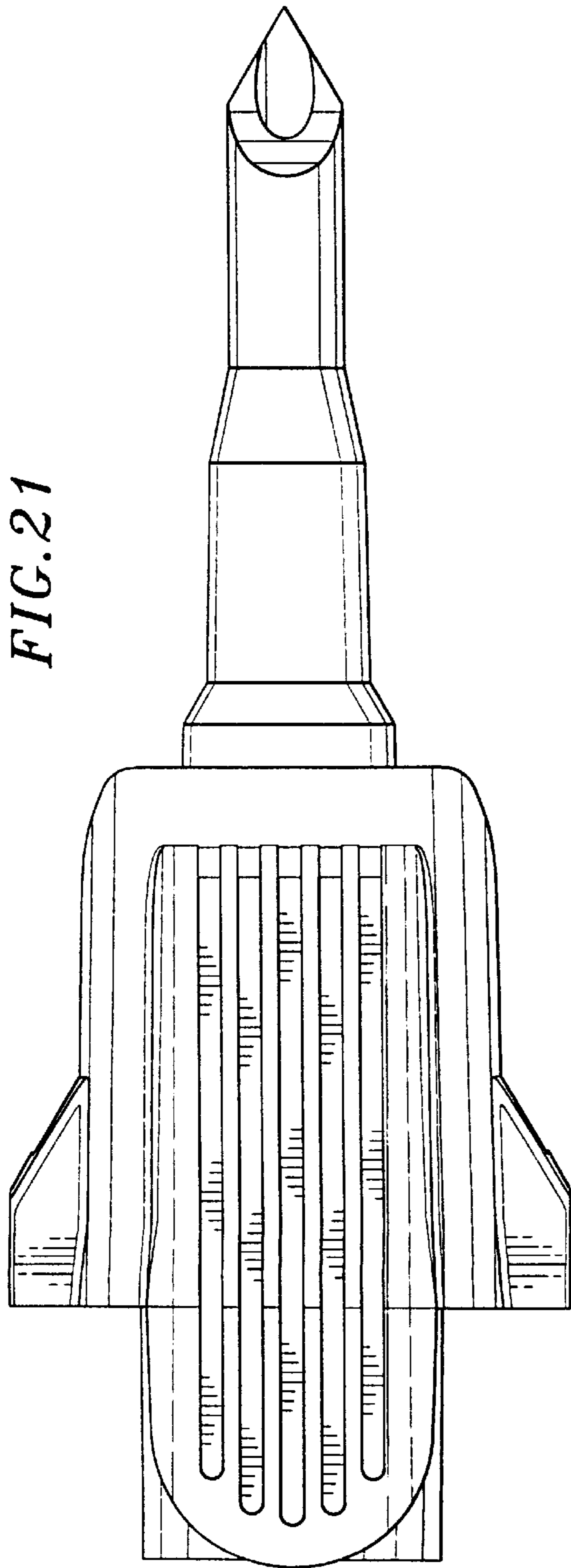

FIG. 20







*FIG. 24*

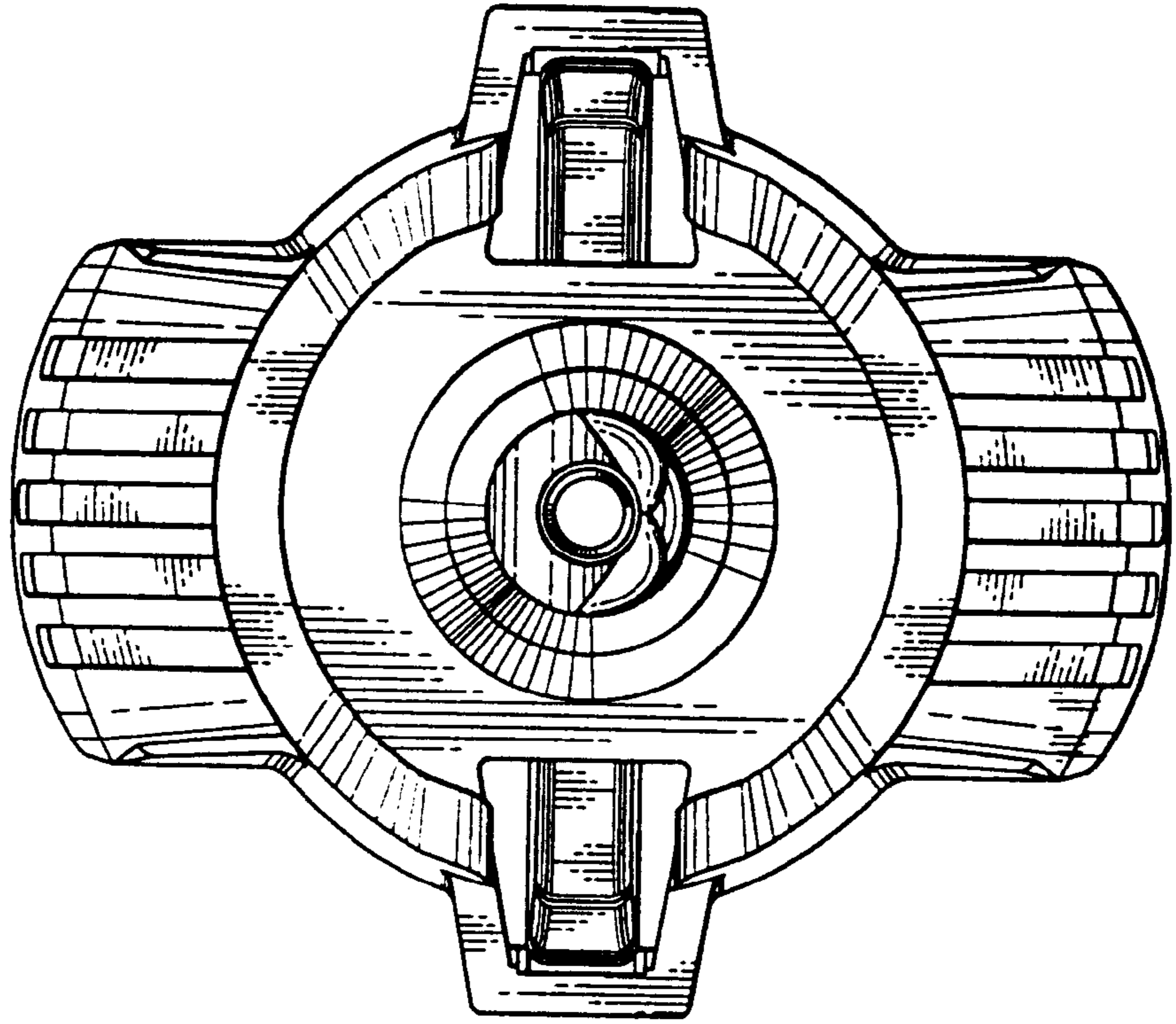

*FIG. 23*

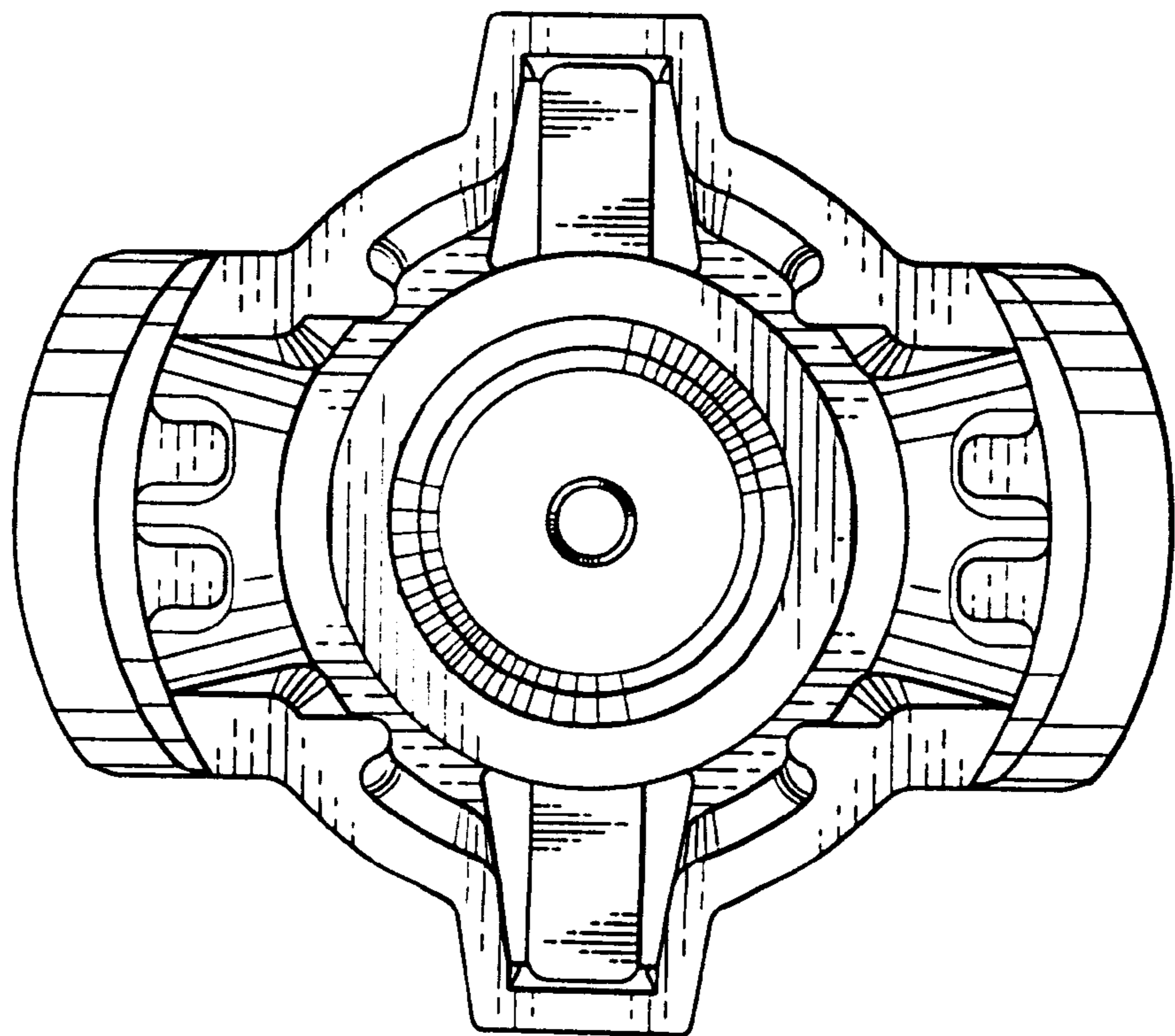
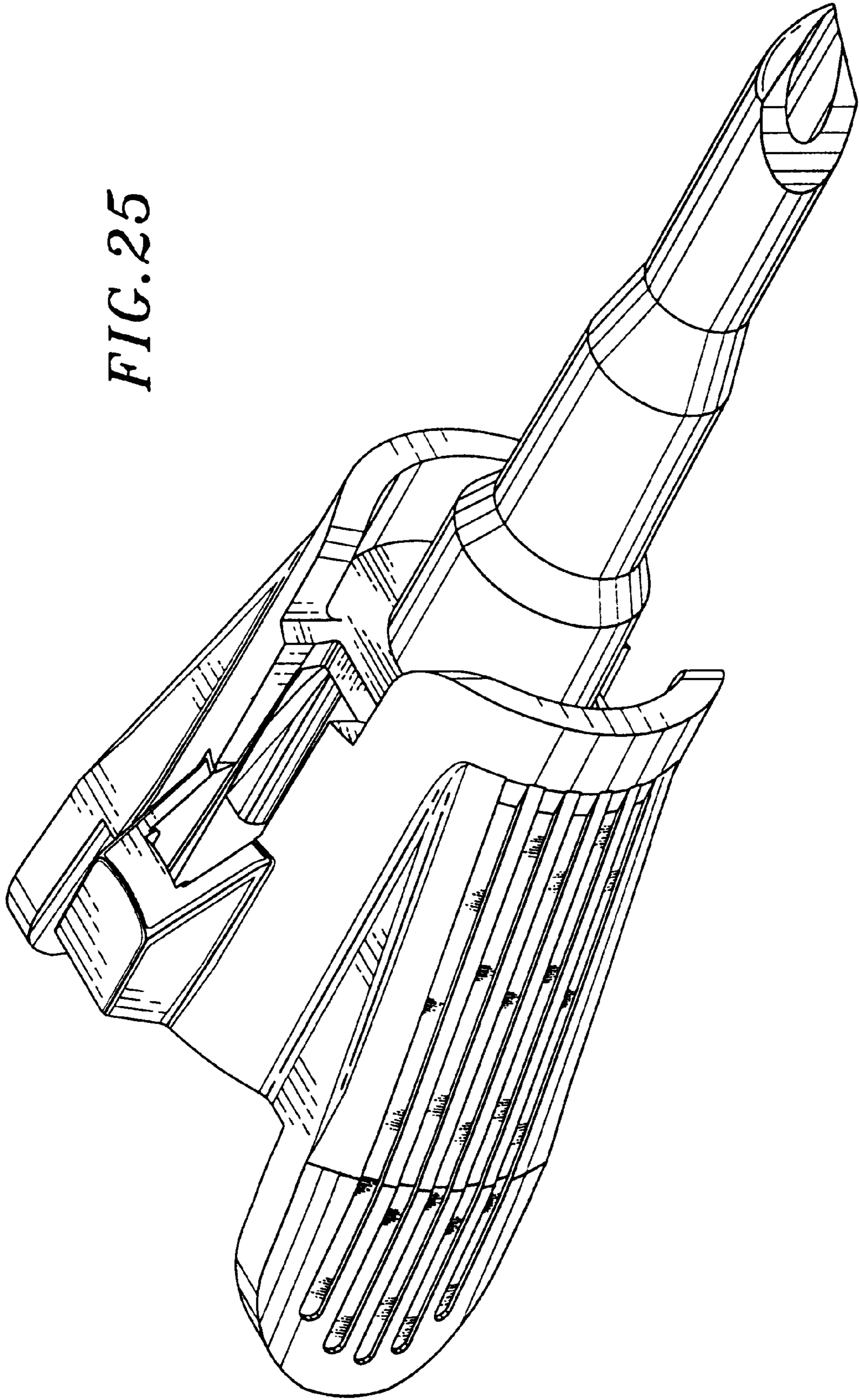

FIG. 25



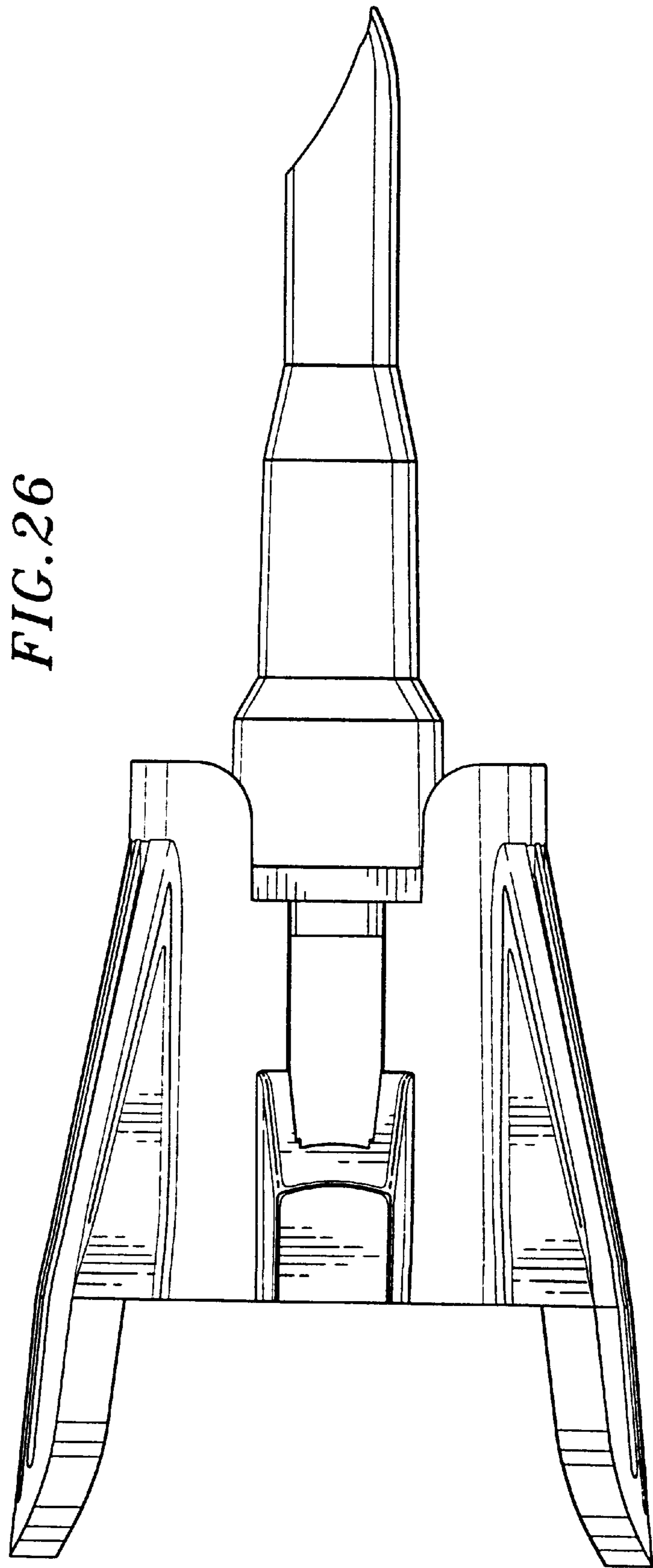
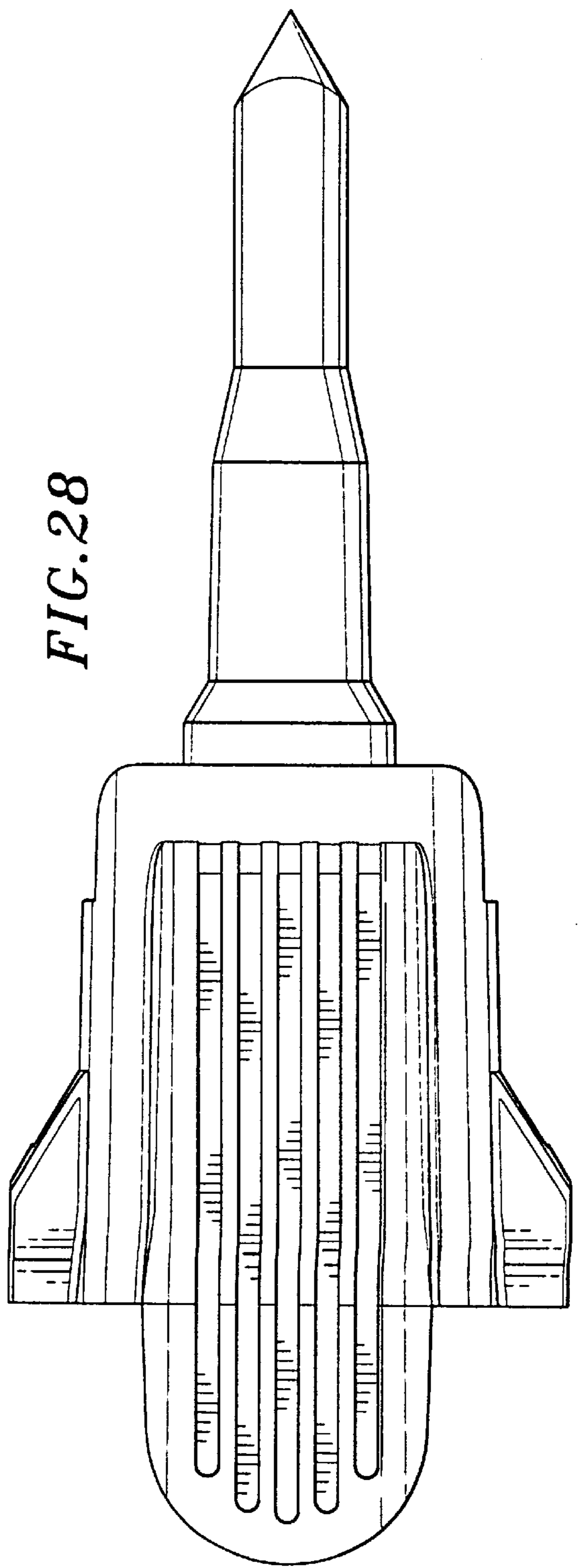
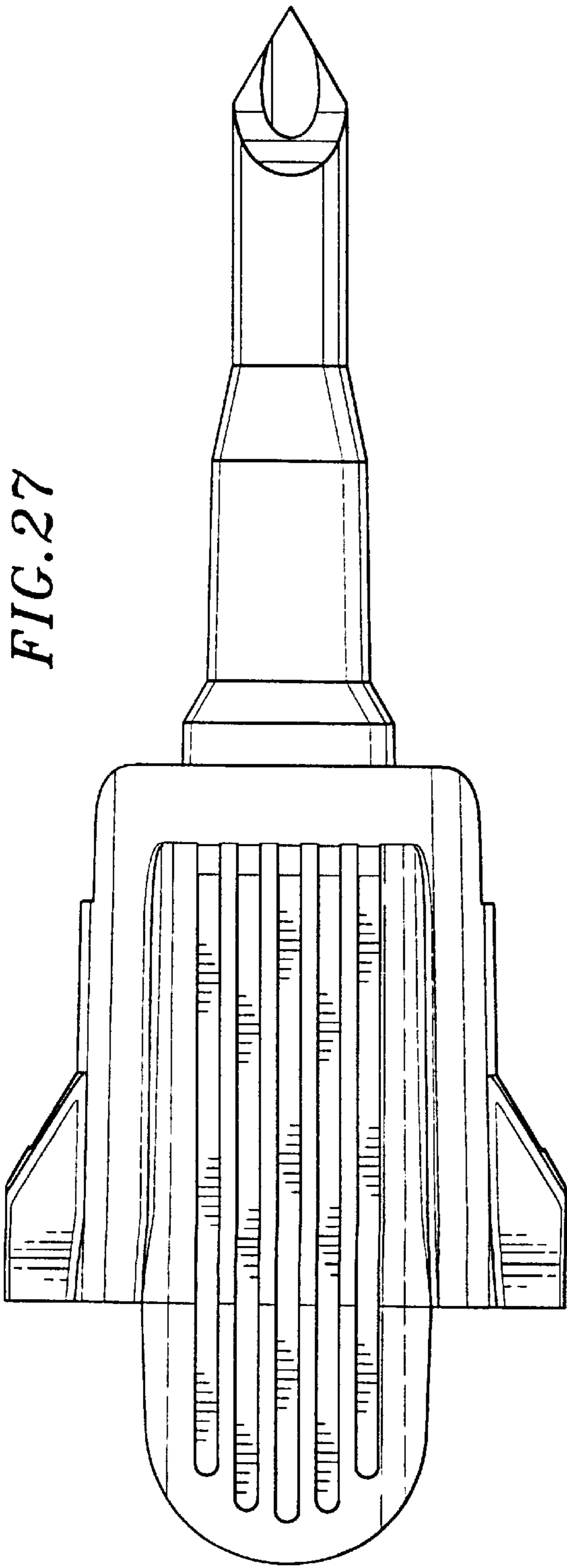
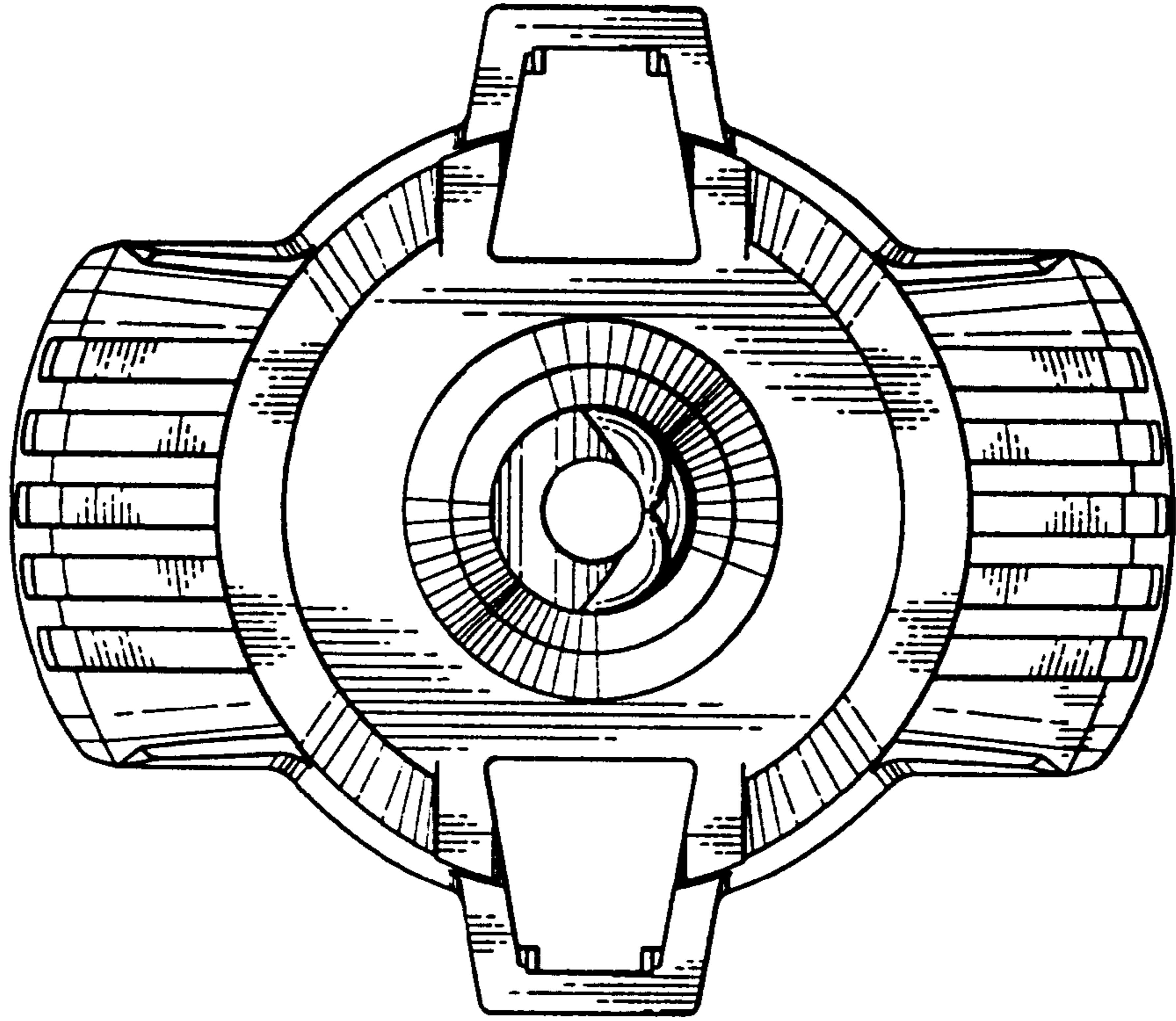

FIG. 26



*FIG. 30*



*FIG. 29*

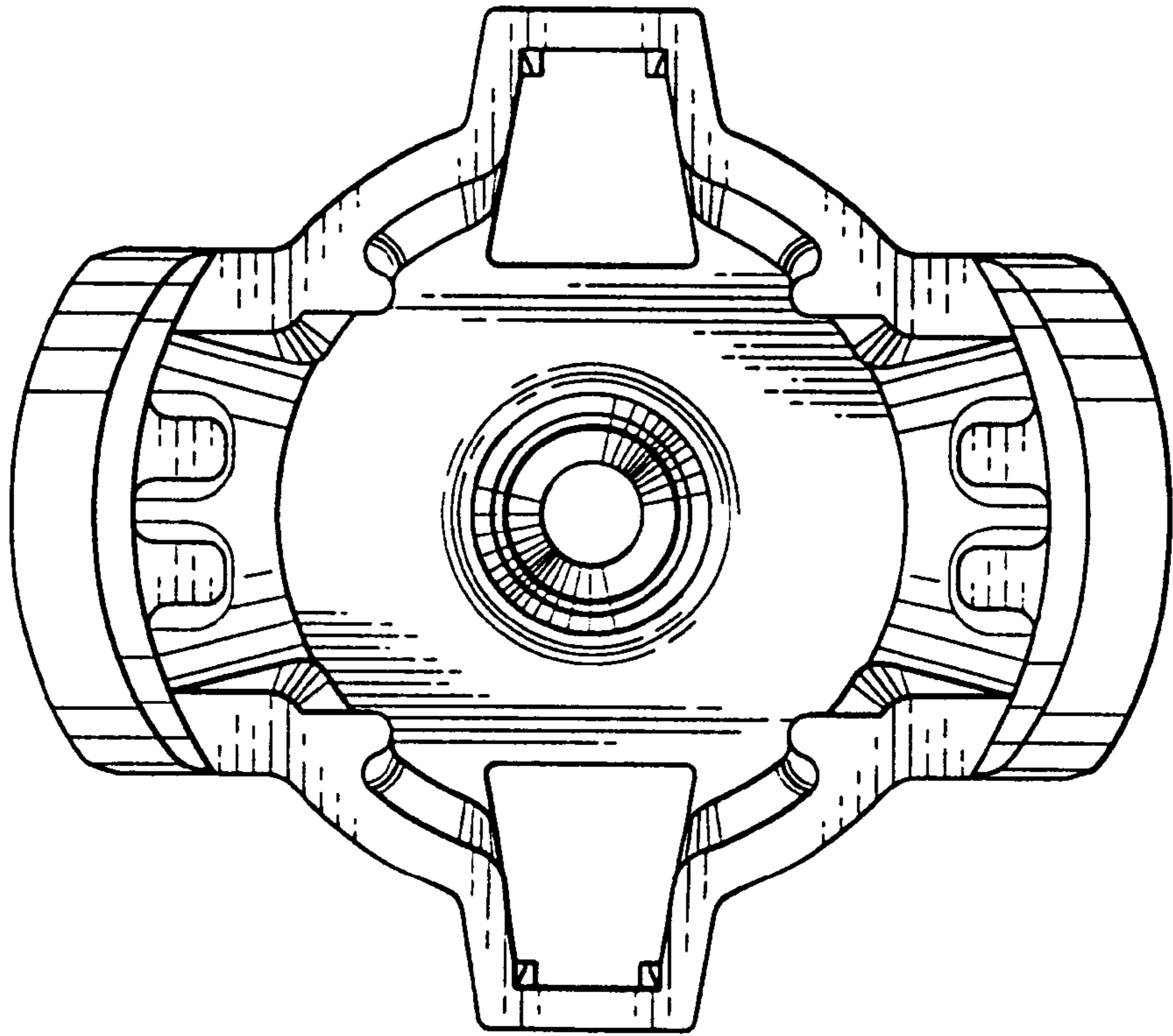

FIG. 31

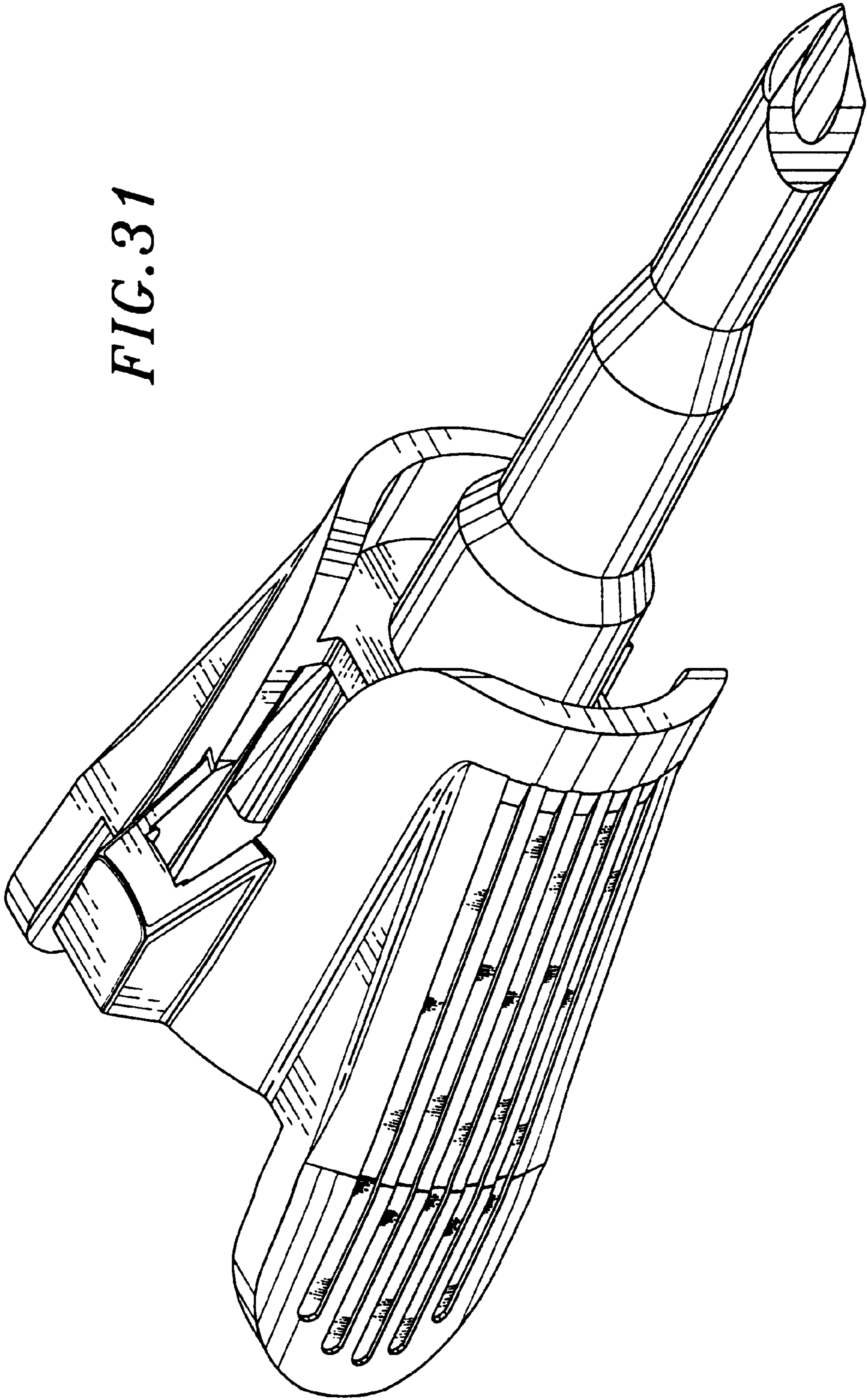
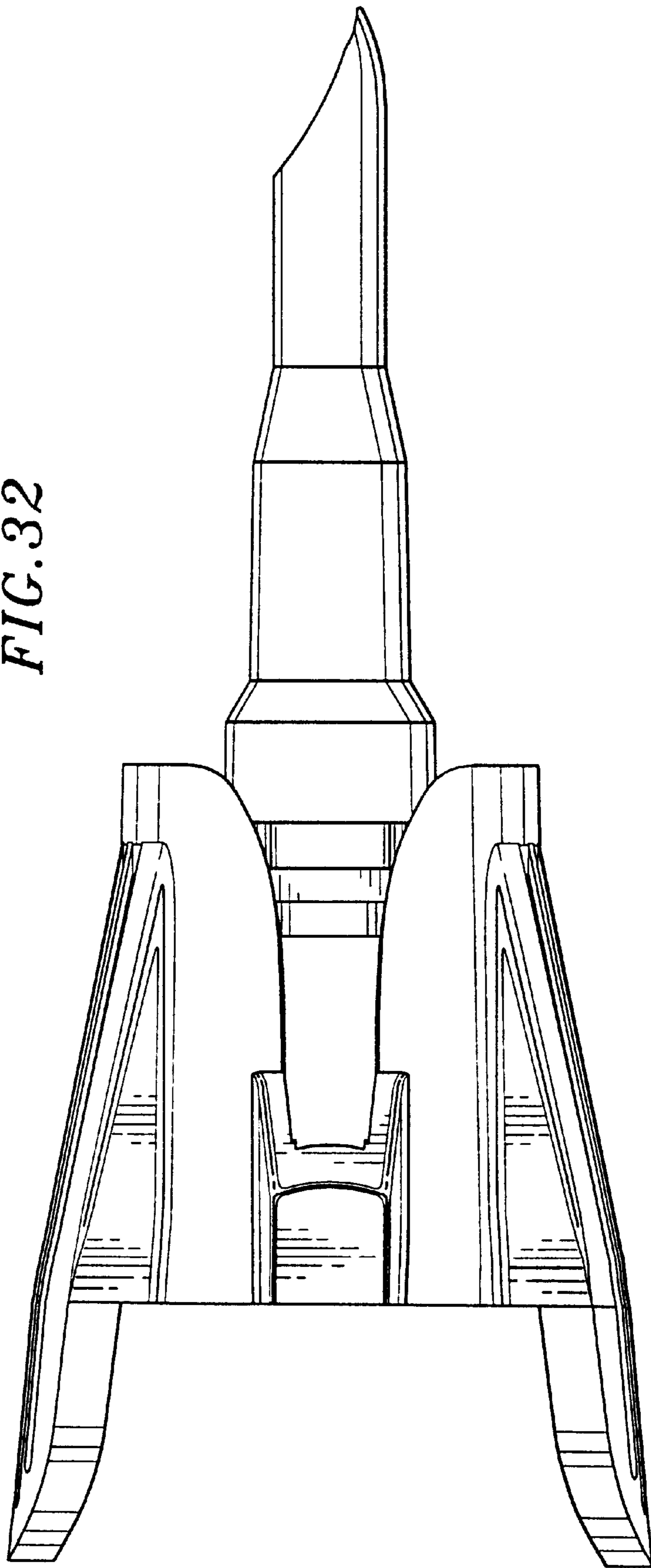
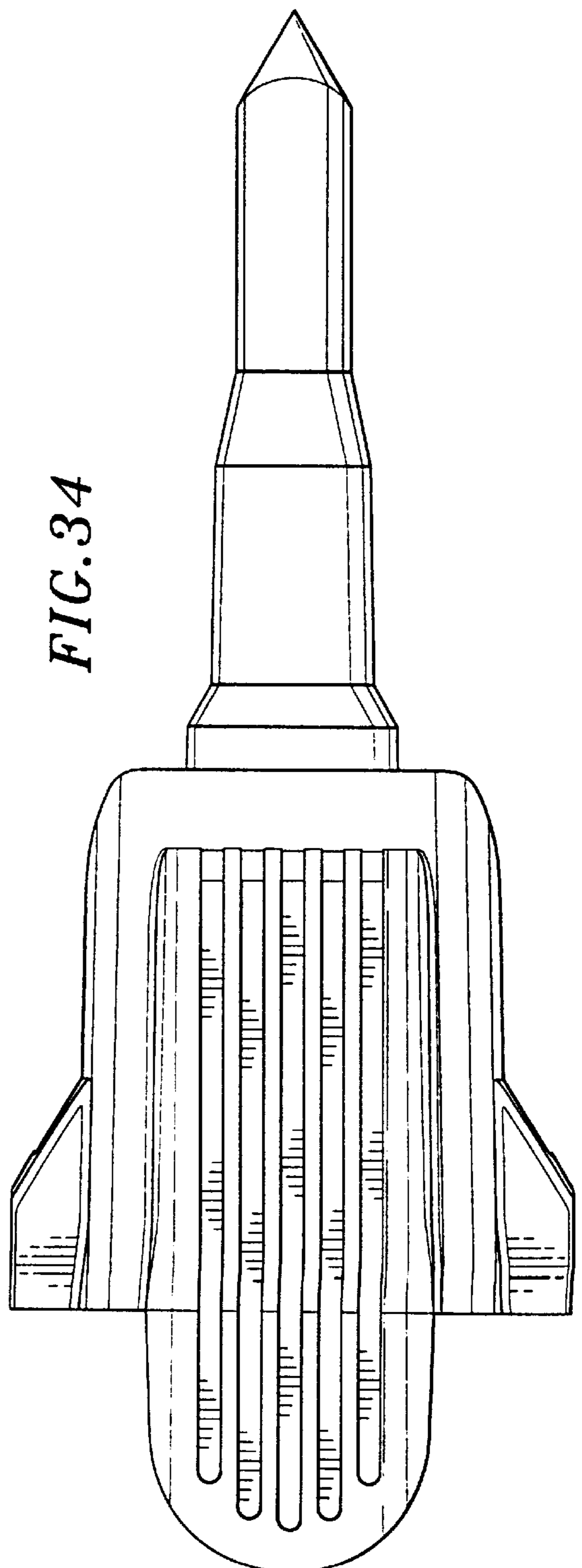
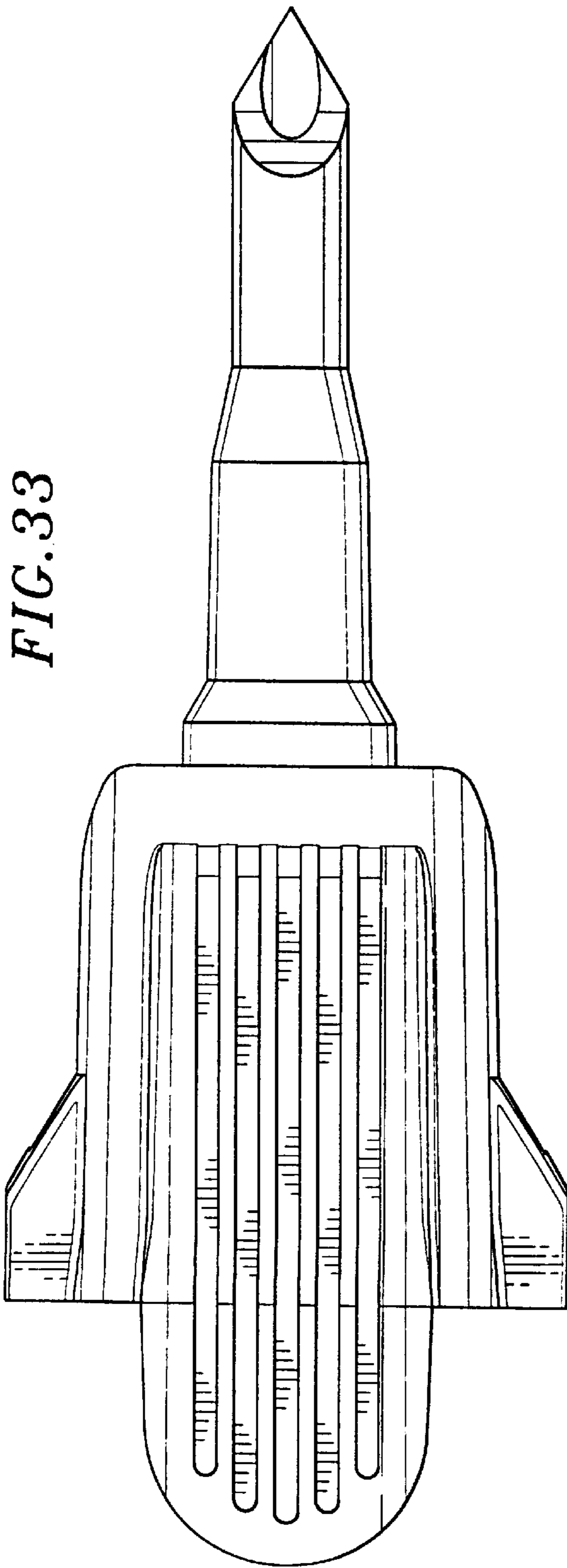

FIG. 32







*FIG. 36*

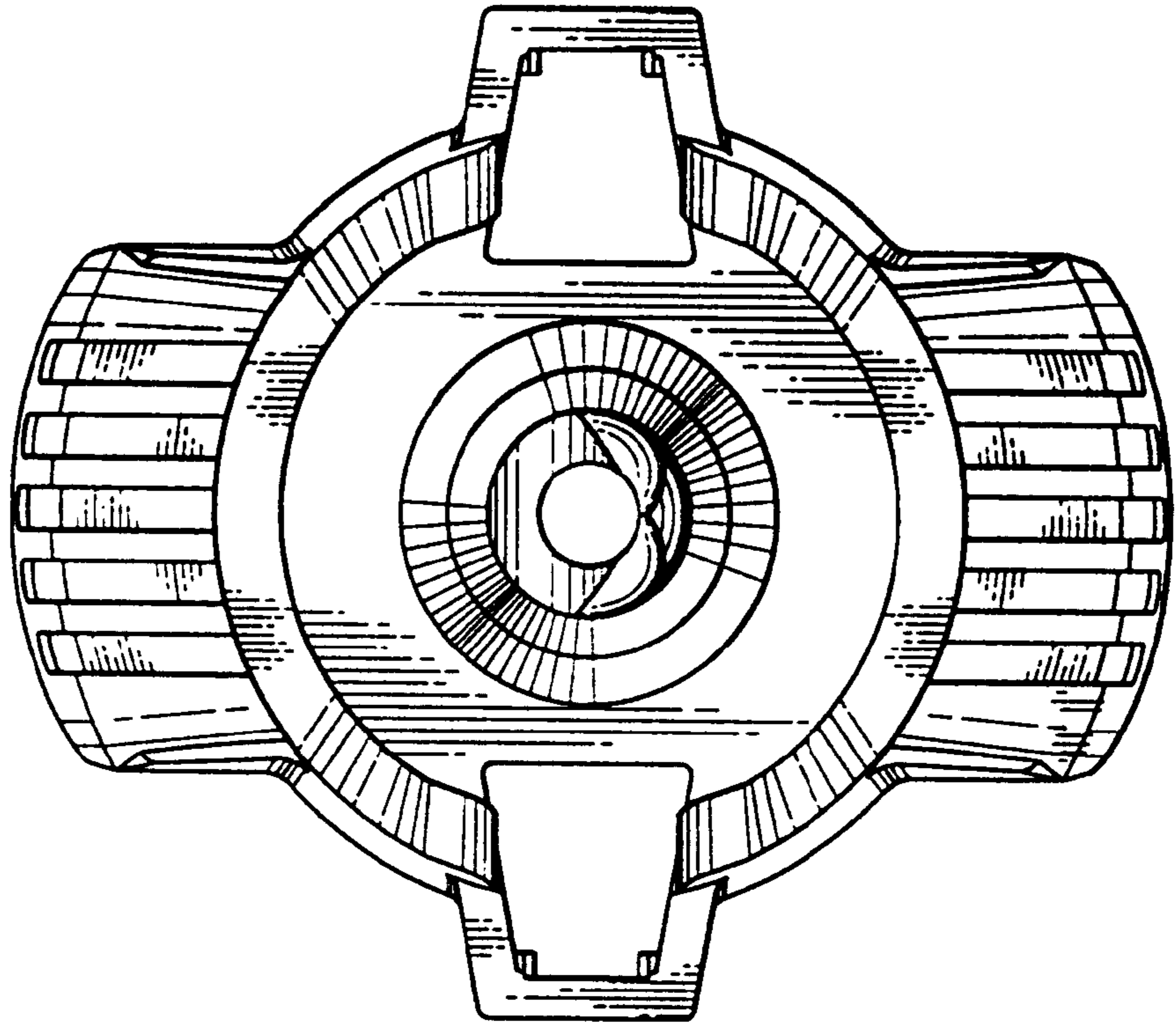

*FIG. 35*

