



US00D415954S

United States Patent [19]

Musselman et al.

[11] Patent Number: Des. 415,954

[45] Date of Patent: ** Nov. 2, 1999

[54] MULTI-SIDED TRACTION STUD

[76] Inventors: Robert Musselman, 290 Richmond Dr.; Douglas Dale, 455 Baker Rd., both of Hope, Mich. 48628

[**] Term: 14 Years

[21] Appl. No.: 29/097,127

[22] Filed: Nov. 30, 1998

[51] LOC (6) Cl. 08-08

[52] U.S. Cl. D8/386

[58] Field of Search D8/387, 388, 382, D8/391, 386; 411/500, 501, 403, 504, 508-510

[56] References Cited

U.S. PATENT DOCUMENTS

D. 268,006	2/1983	Wollar	D8/382
D. 337,255	7/1993	Novelli, Sr.	D8/356
862,434	8/1907	Bartel .		
862,435	8/1907	Bartel .		
4,858,697	8/1989	Sherblom	172/21
5,199,771	4/1993	James et al.	305/54
5,299,860	4/1994	Anderson	305/54
5,642,921	7/1997	Webb et al.	305/179
5,676,437	10/1997	Holmgren et al.	305/189
5,685,621	11/1997	Nugent	305/180
5,690,398	11/1997	Pribyl	305/162
5,716,112	2/1998	Staszak	305/180

OTHER PUBLICATIONS

Fastex catalog, p. 6, head clip located at top of page, Jun. 1984.

Primary Examiner—Holly Baynham

[57] CLAIM

The ornamental design for a multi-sided traction stud, as shown and described.

DESCRIPTION

FIG. 1 front elevational view of a preferred embodiment of a multi-sided traction stud illustrating our new design of the present invention, it being understood that the back side and the left side and right side as viewed in FIG. 1 are mirror images thereof;

FIG. 2 is a top plan view thereof;

FIG. 3 is a side elevational view thereof, taken along the line 3—3 of FIG. 2;

FIG. 4 is a bottom plan view thereof;

FIG. 5 is a perspective view thereof;

FIG. 6 is a front elevational view similar to FIG. 1 of a slightly modified multi-sided traction stud illustrating a slightly modified design, it being understood that the back side and right and left sides, as viewed in FIG. 6 are mirror images of the design illustrated in FIG. 6;

FIG. 7 is a top plan view of the multi-sided traction stud illustrated in FIG. 6; and,

FIG. 8 is a front perspective view of the embodiment illustrated in FIGS. 6 and 7.

1 Claim, 2 Drawing Sheets

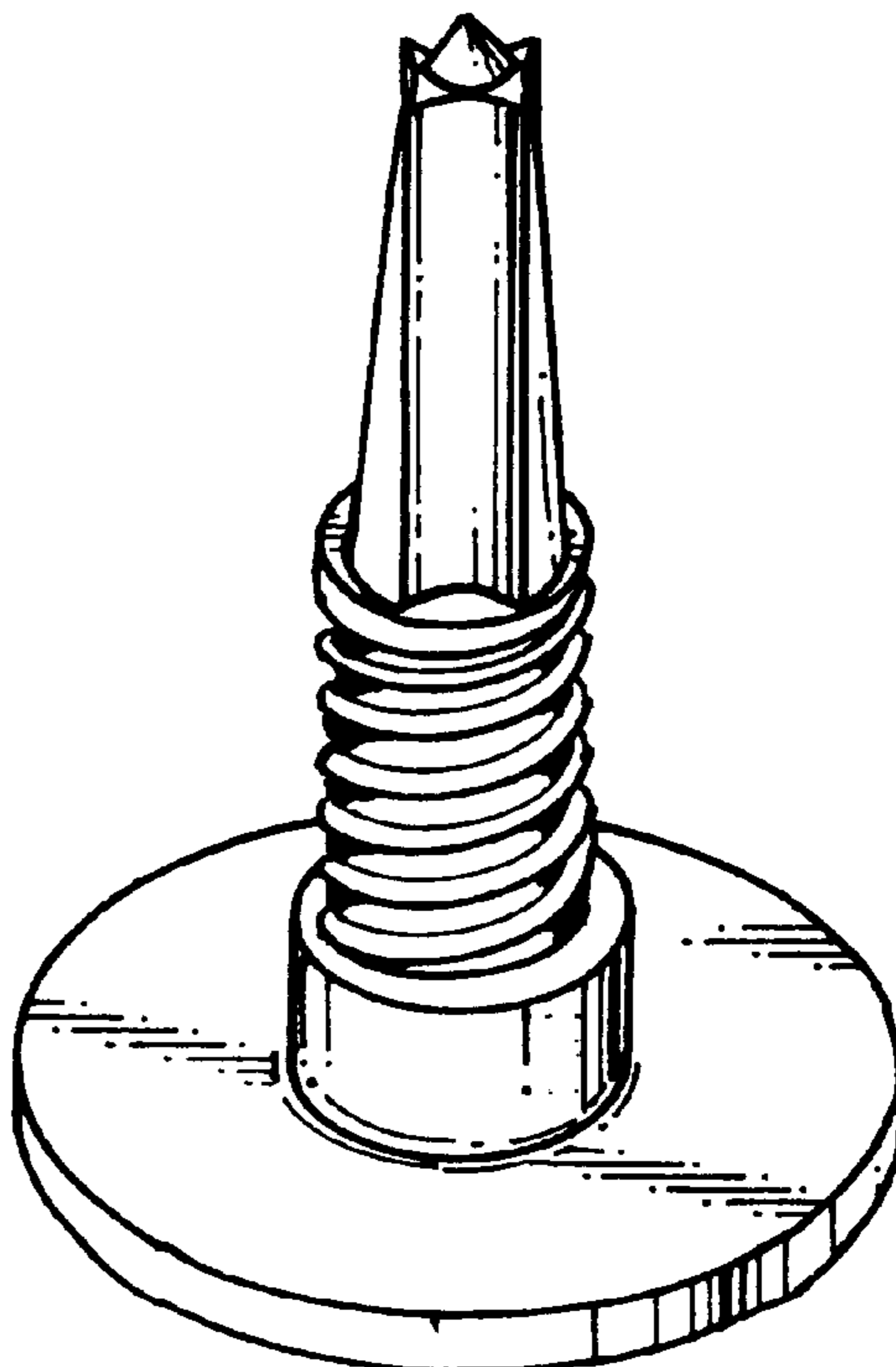
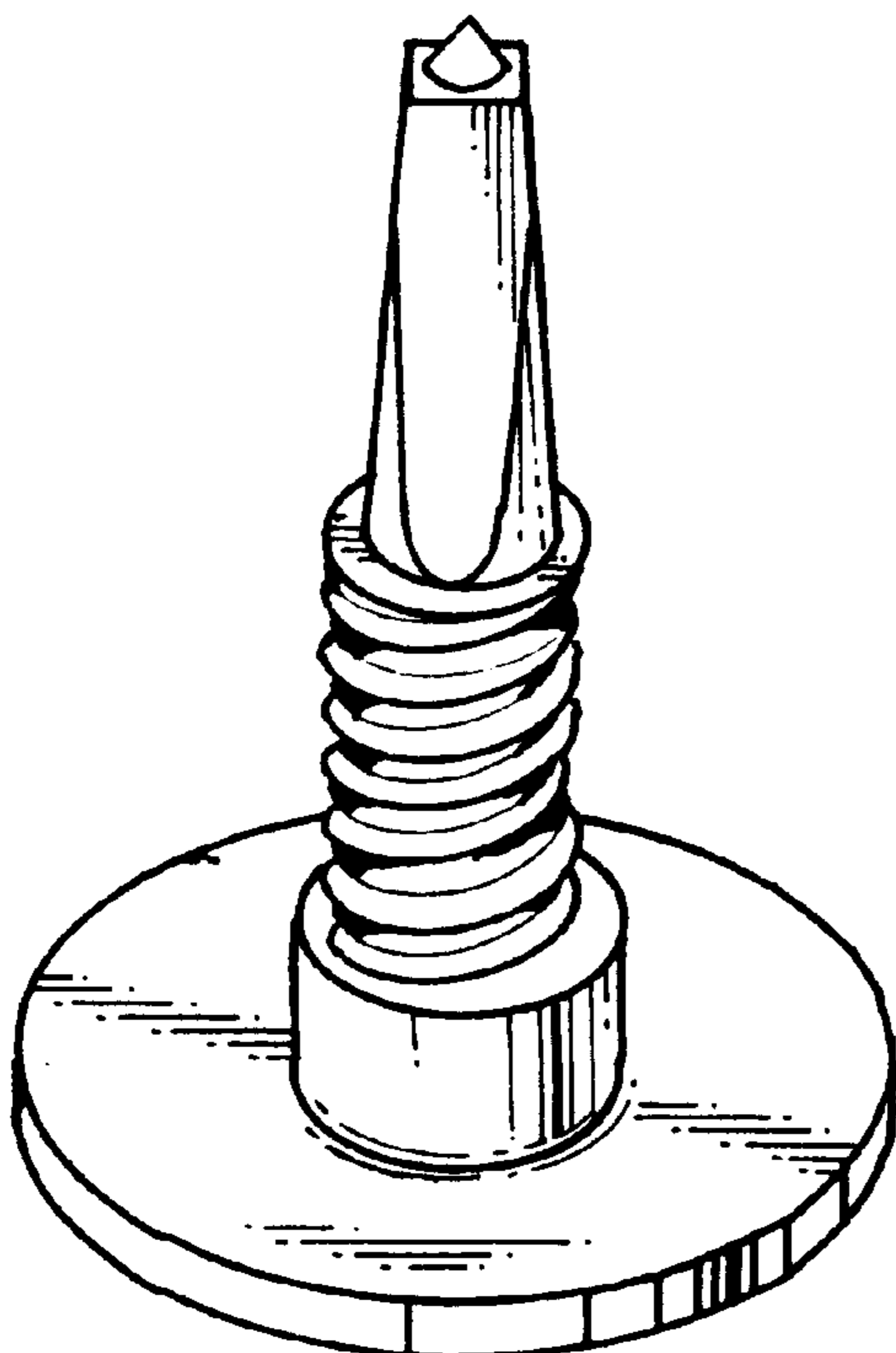

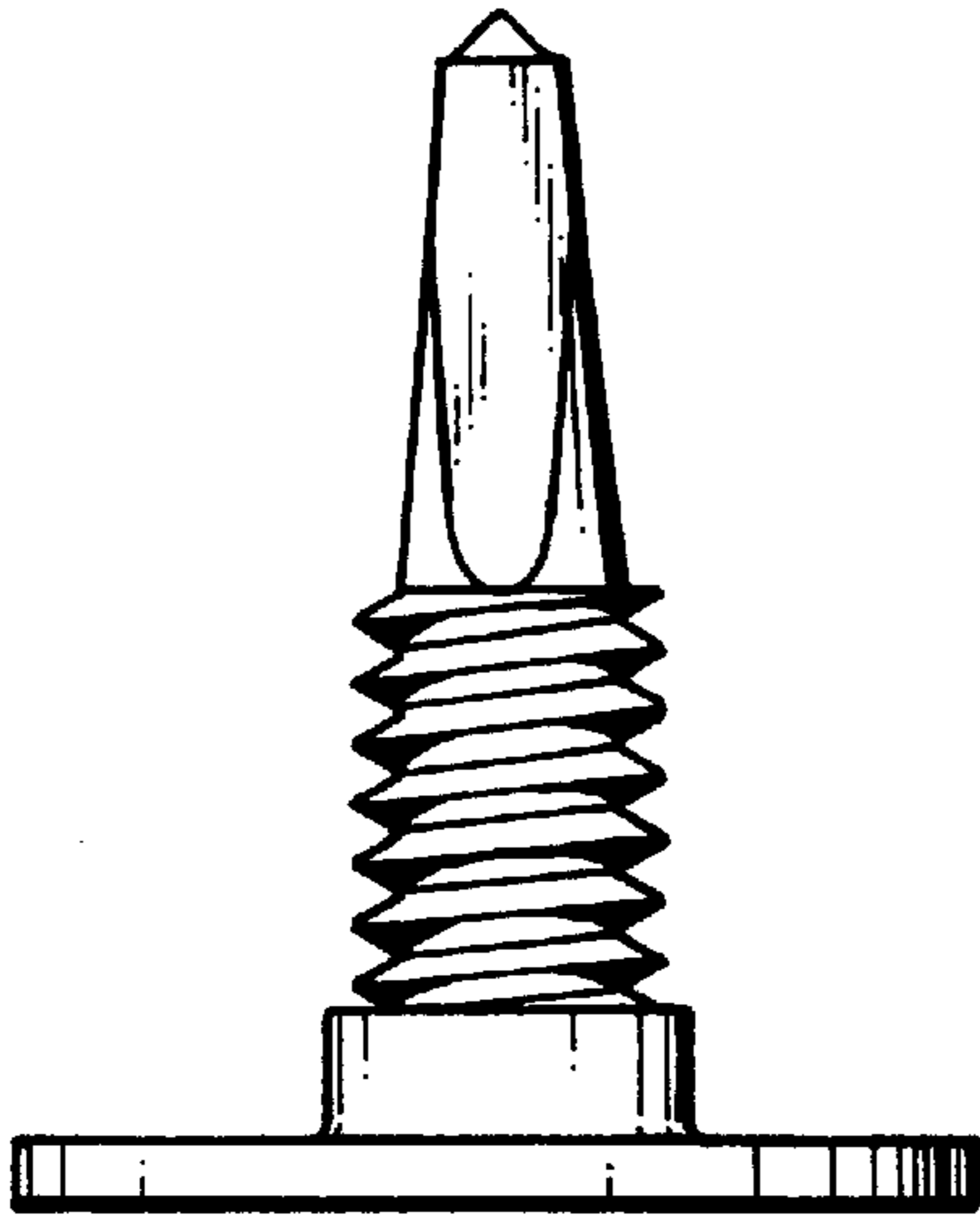

Fig. 1

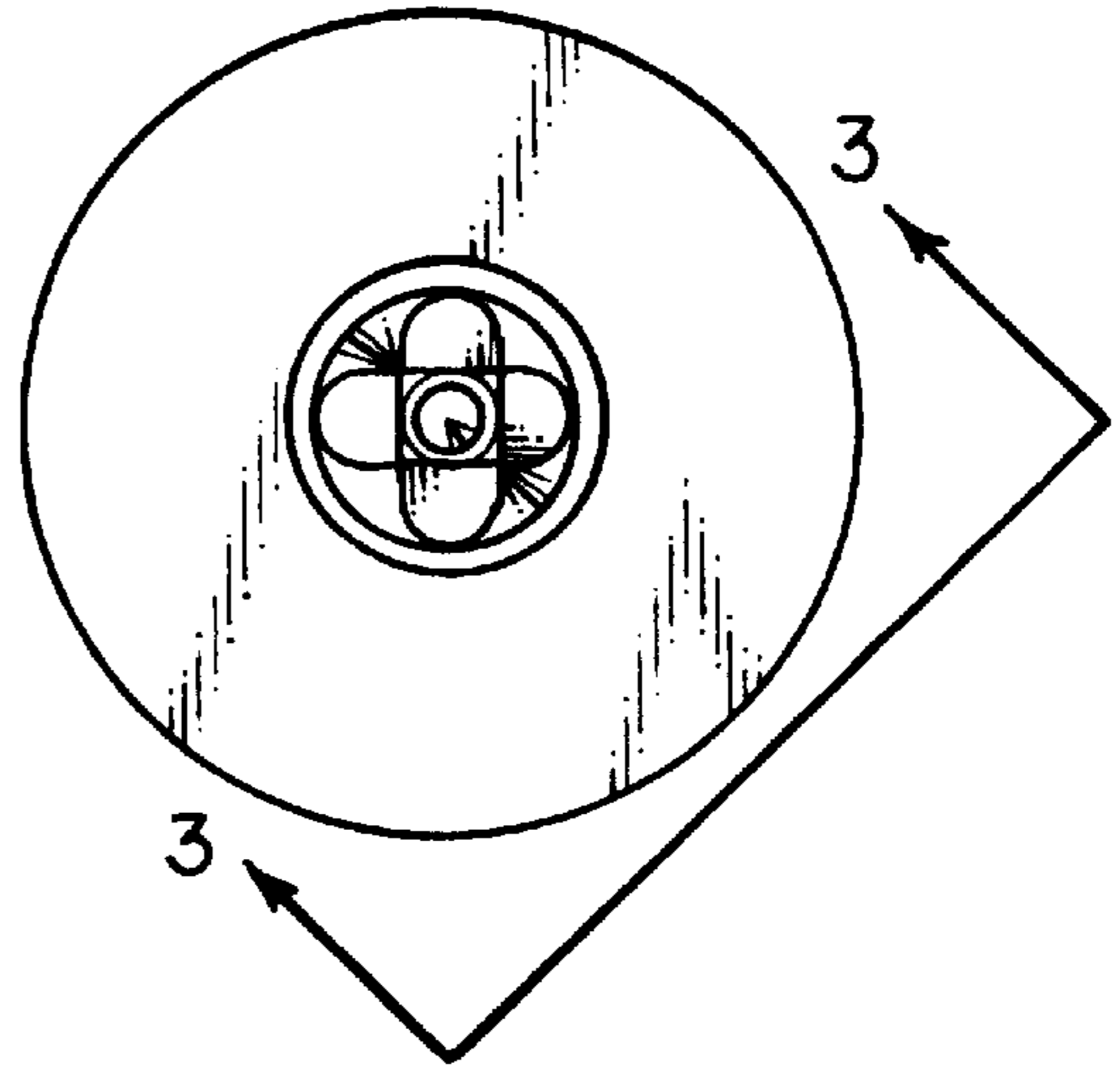

Fig. 2

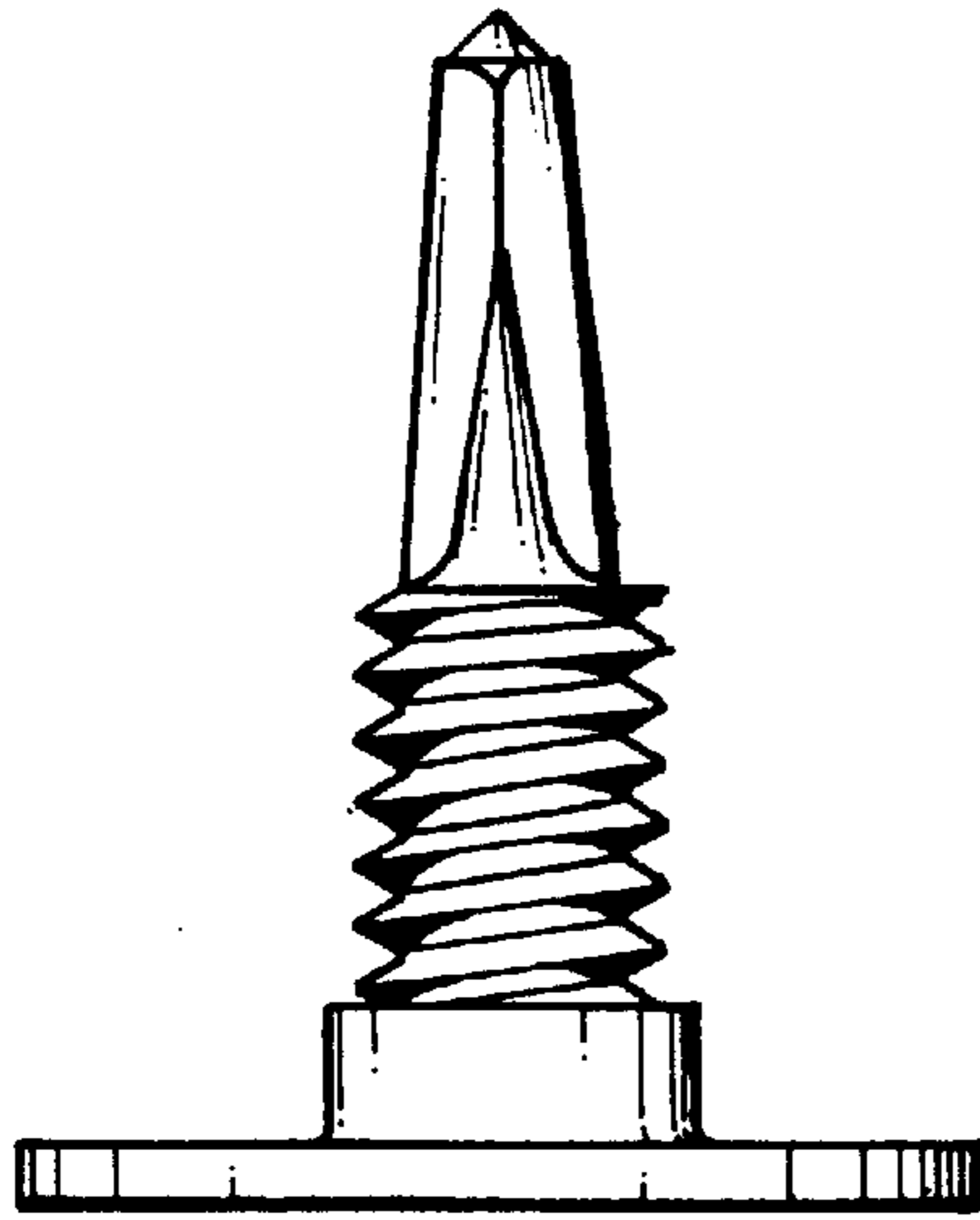

Fig. 3

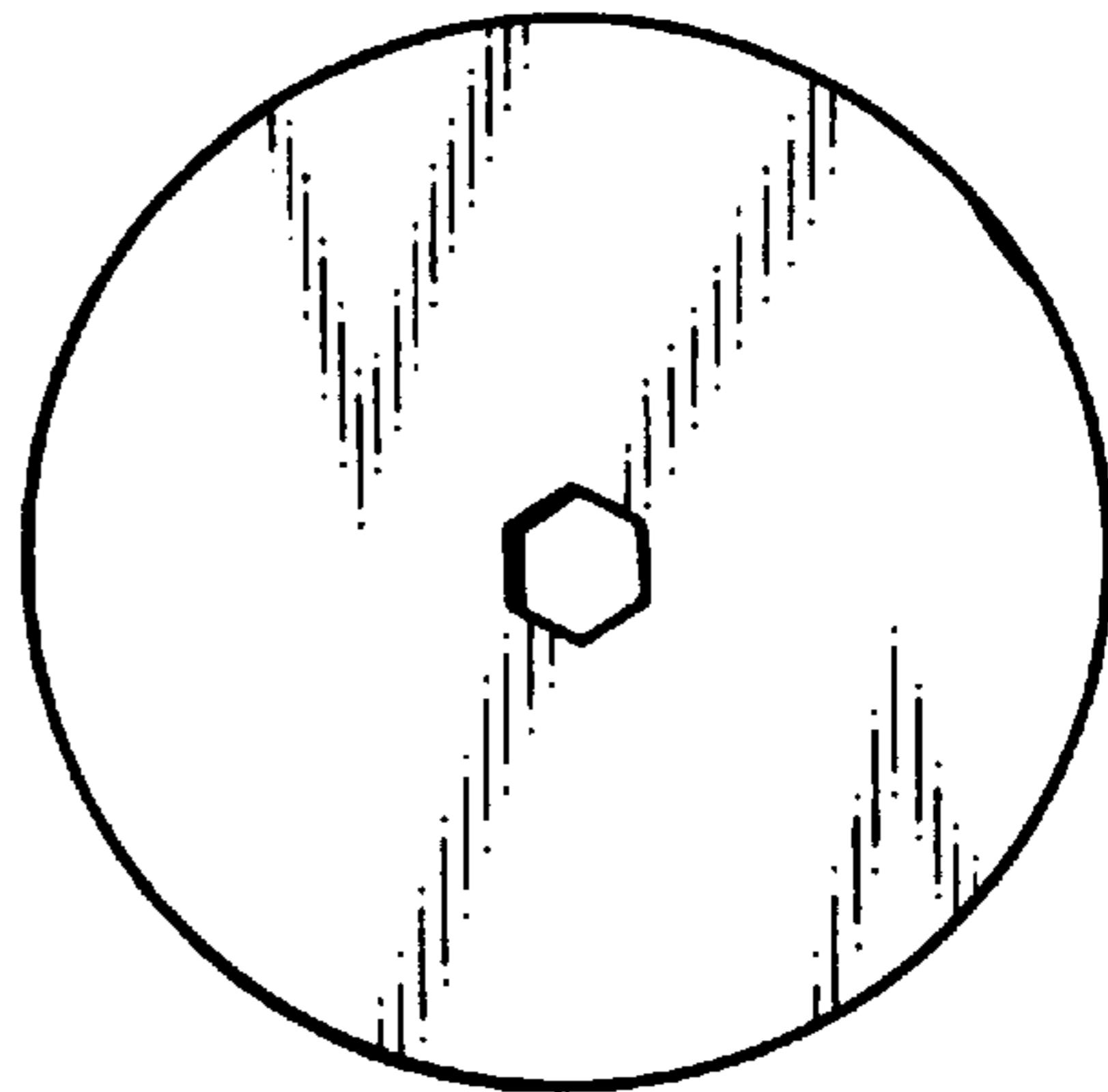

Fig. 4

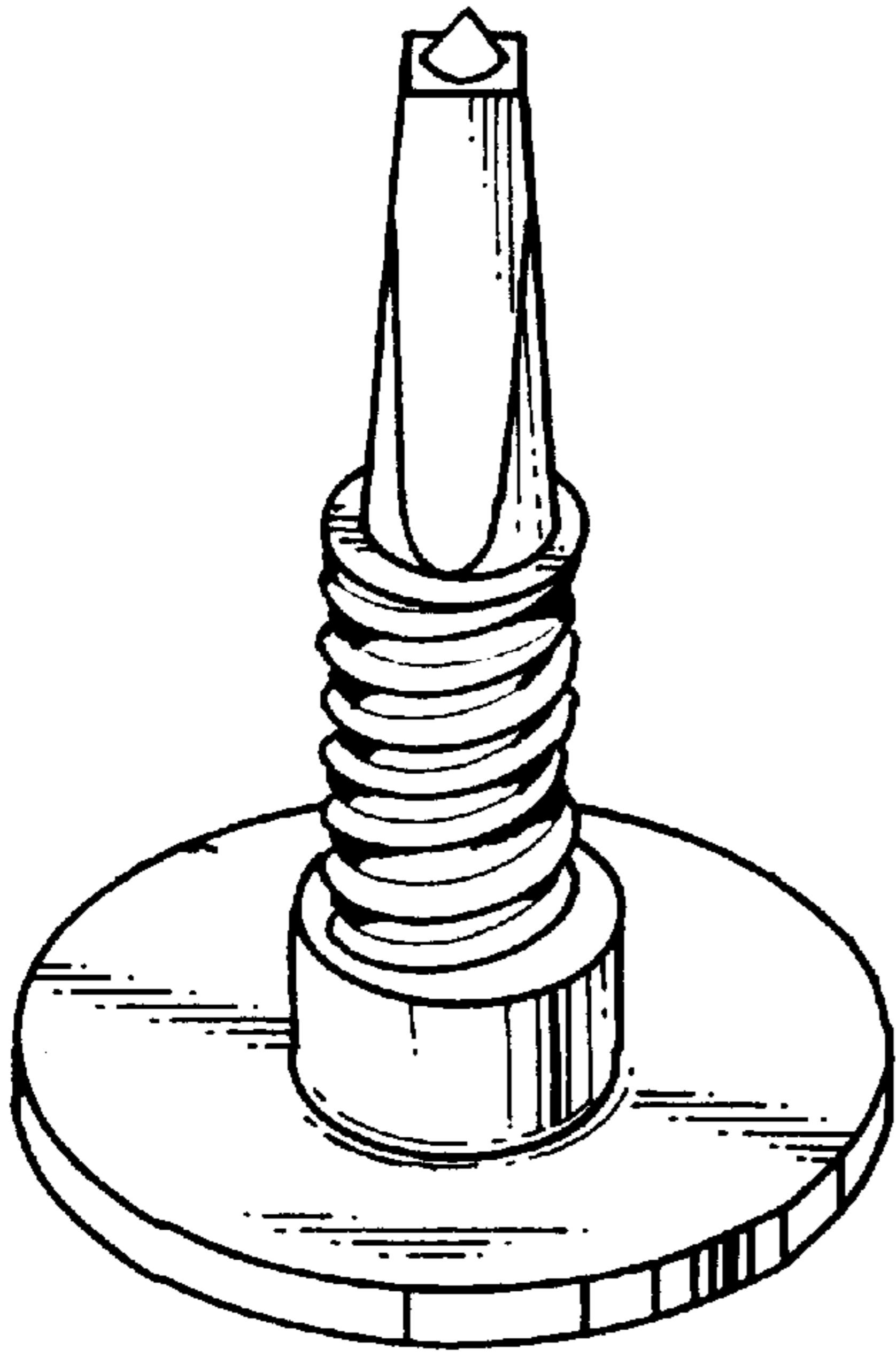

Fig. 5

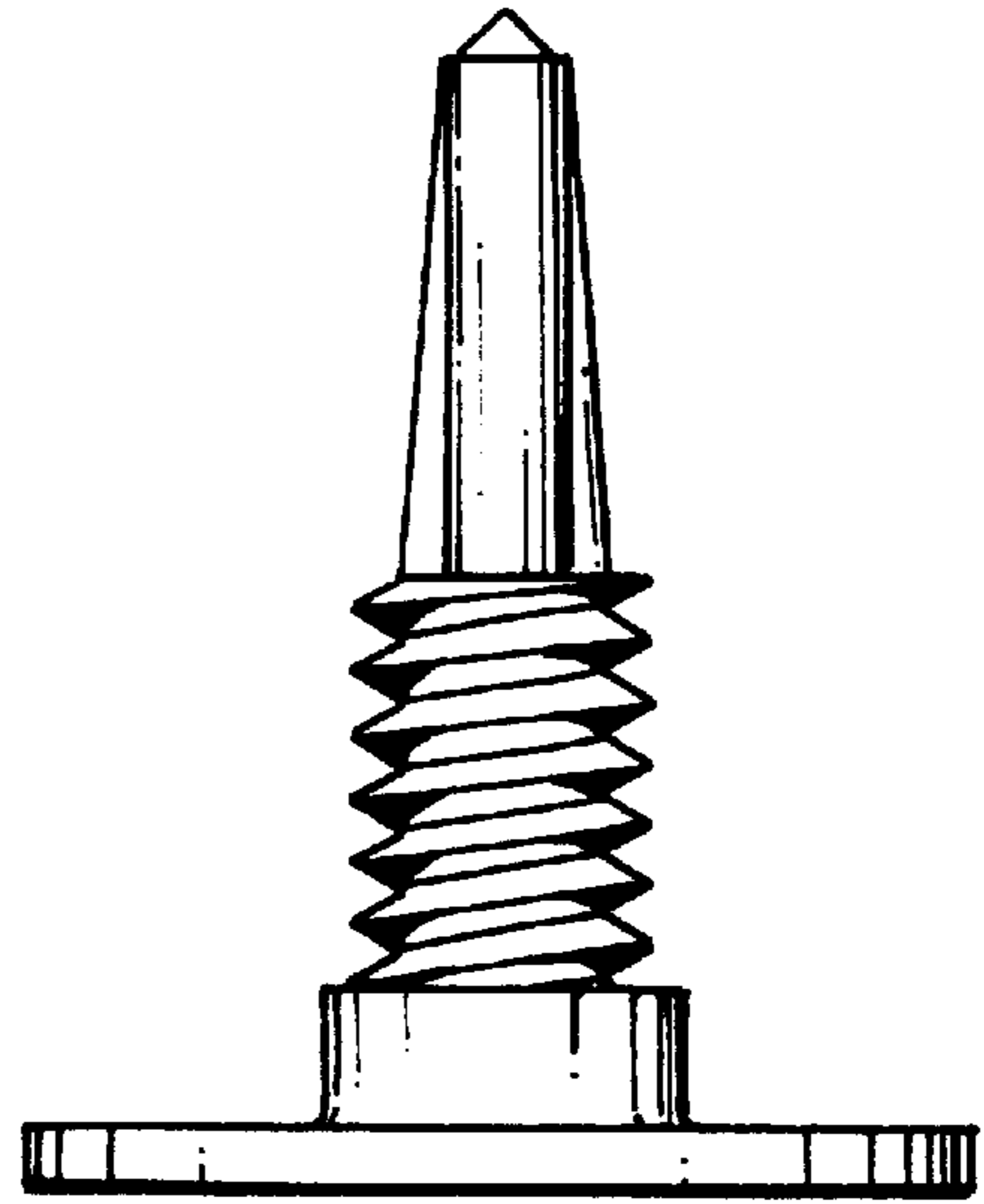

Fig. 6

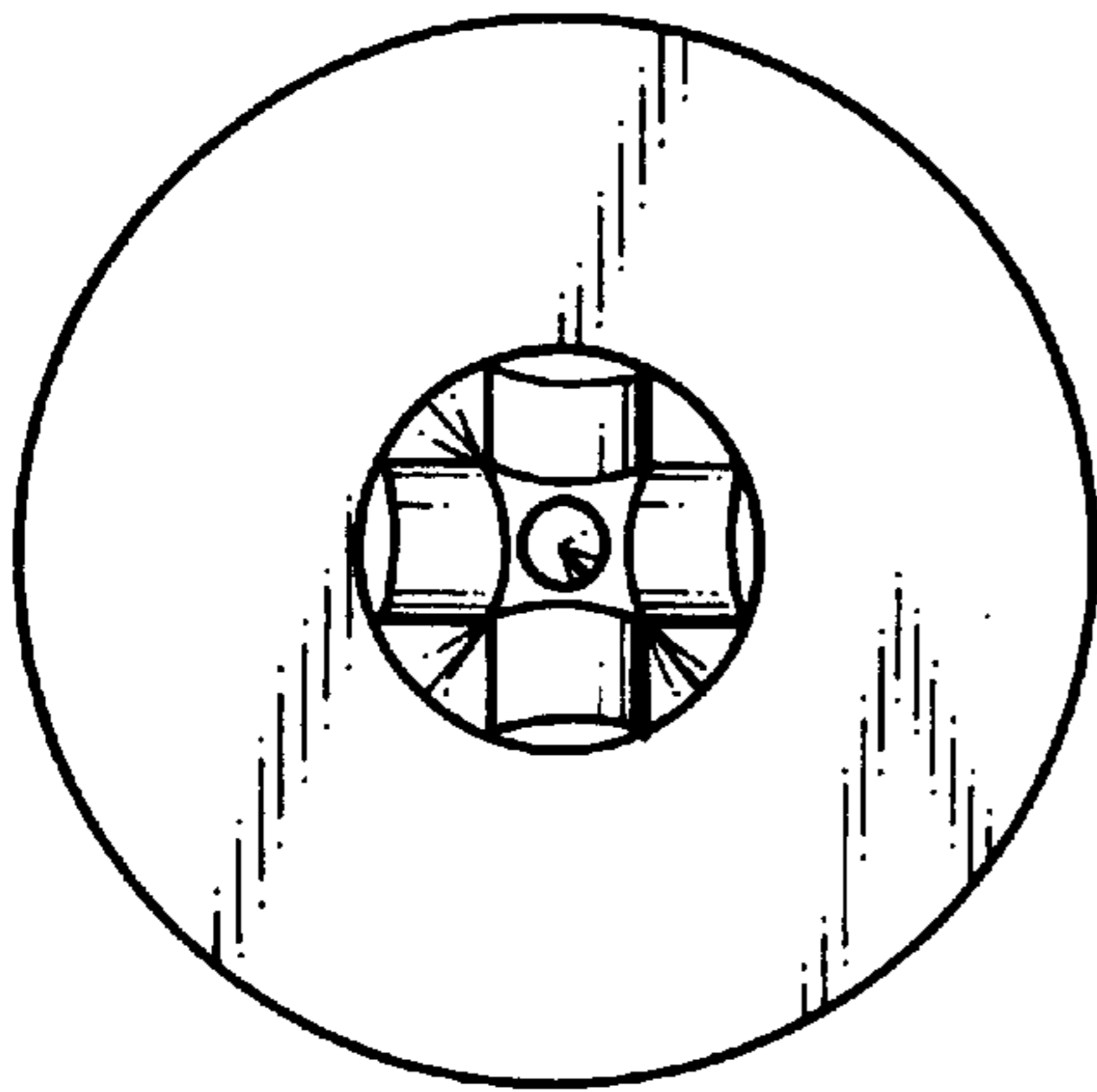

Fig. 7

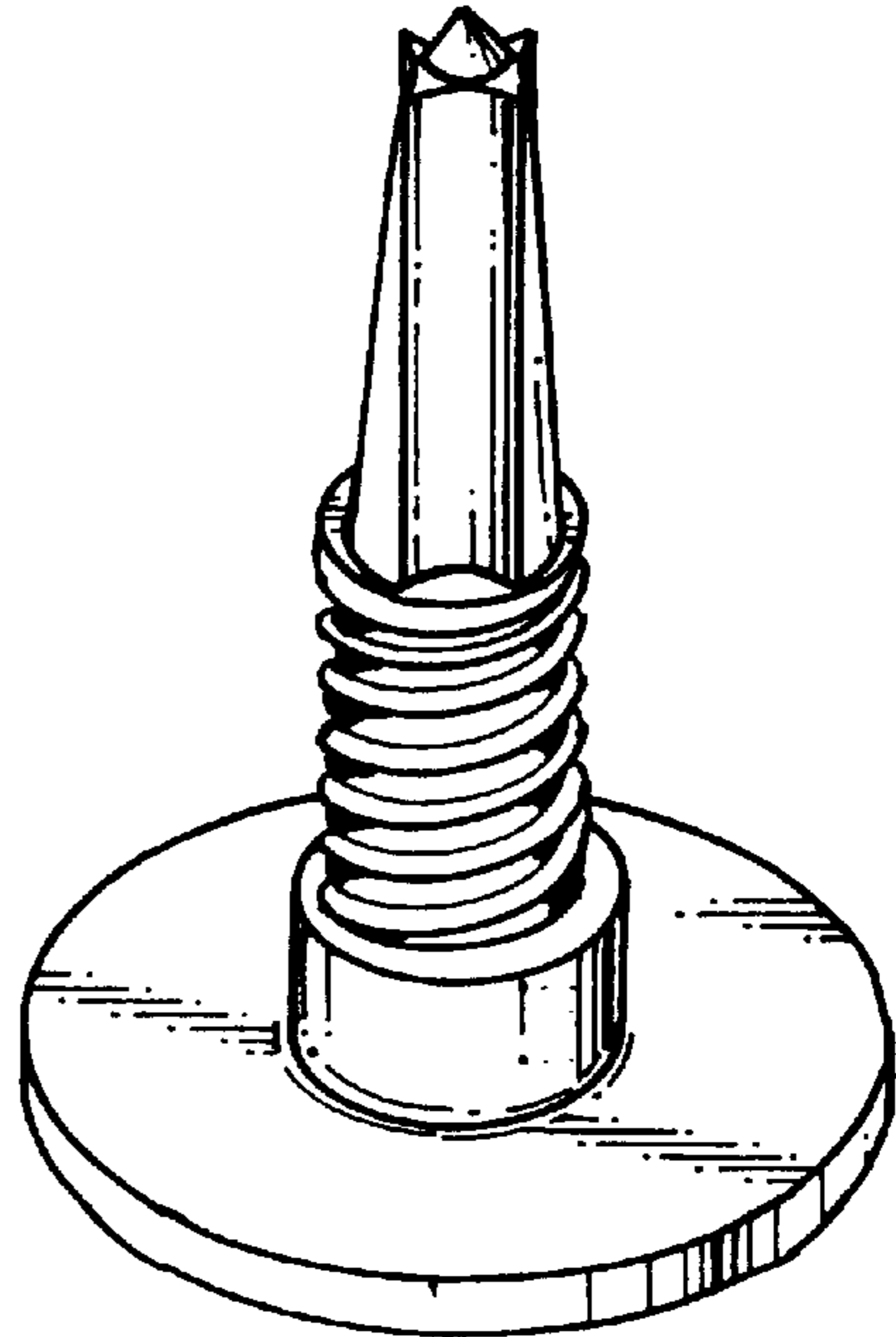

Fig. 8