



US00D415507S

United States Patent [19]

[11] **Patent Number: Des. 415,507**

Rogers et al.

[45] **Date of Patent: ** Oct. 19, 1999**

[54] **HYDROCYCLONE FEED ASSEMBLY COVER LINER**

Attorney, Agent, or Firm—Cesari and McKenna, LLP

[75] Inventors: **Brian Leslie Rogers**, Woronora Heights; **Michael Arthur West**, Frenchs Forest, both of Australia

[57] **CLAIM**

The ornamental design for a hydrocyclone feed assembly cover liner, as shown.

[73] Assignee: **Warman International Limited**, Australia

DESCRIPTION

[**] Term: **14 Years**

FIG. 1 is a perspective view from above of a hydrocyclone feed assembly cover liner showing the new design; FIG. 2 is a perspective view from below thereof; FIG. 3 is a top plan view thereof; FIG. 4 is a bottom plan view thereof; FIG. 5 is an elevational view of a first side thereof; FIG. 6 is an elevational view of a second side thereof; FIG. 7 is an elevational view of a third side thereof; FIG. 8 is an elevational view of a fourth side thereof; FIG. 9 is a view similar to FIG. 1 of a second embodiment of our hydrocyclone feed assembly cover liner design; FIG. 10 is a view similar to FIG. 2 thereof; FIG. 11 is a top plan view thereof; FIG. 12 is a bottom plan view thereof; FIG. 13 is an elevational view of a first side thereof; FIG. 14 is an elevational view of a second side thereof; FIG. 15 is an elevational view of a third side thereof; and, FIG. 16 is an elevational view of a fourth side thereof.

[21] Appl. No.: **29/091,738**

[22] Filed: **Aug. 5, 1998**

[51] **LOC (6) Cl.** **15-09**

[52] **U.S. Cl.** **D15/147**

[58] **Field of Search** D15/147; 209/11, 209/721, 728, 732, 734; 210/175, 512.2, 787

[56] **References Cited**

U.S. PATENT DOCUMENTS

3,335,860	8/1967	Baxter, Jr.	209/734
4,652,363	3/1987	Miller	209/734
5,383,941	1/1995	Nemedi	210/787 X

Primary Examiner—Antoine Duval Davis

1 Claim, 6 Drawing Sheets

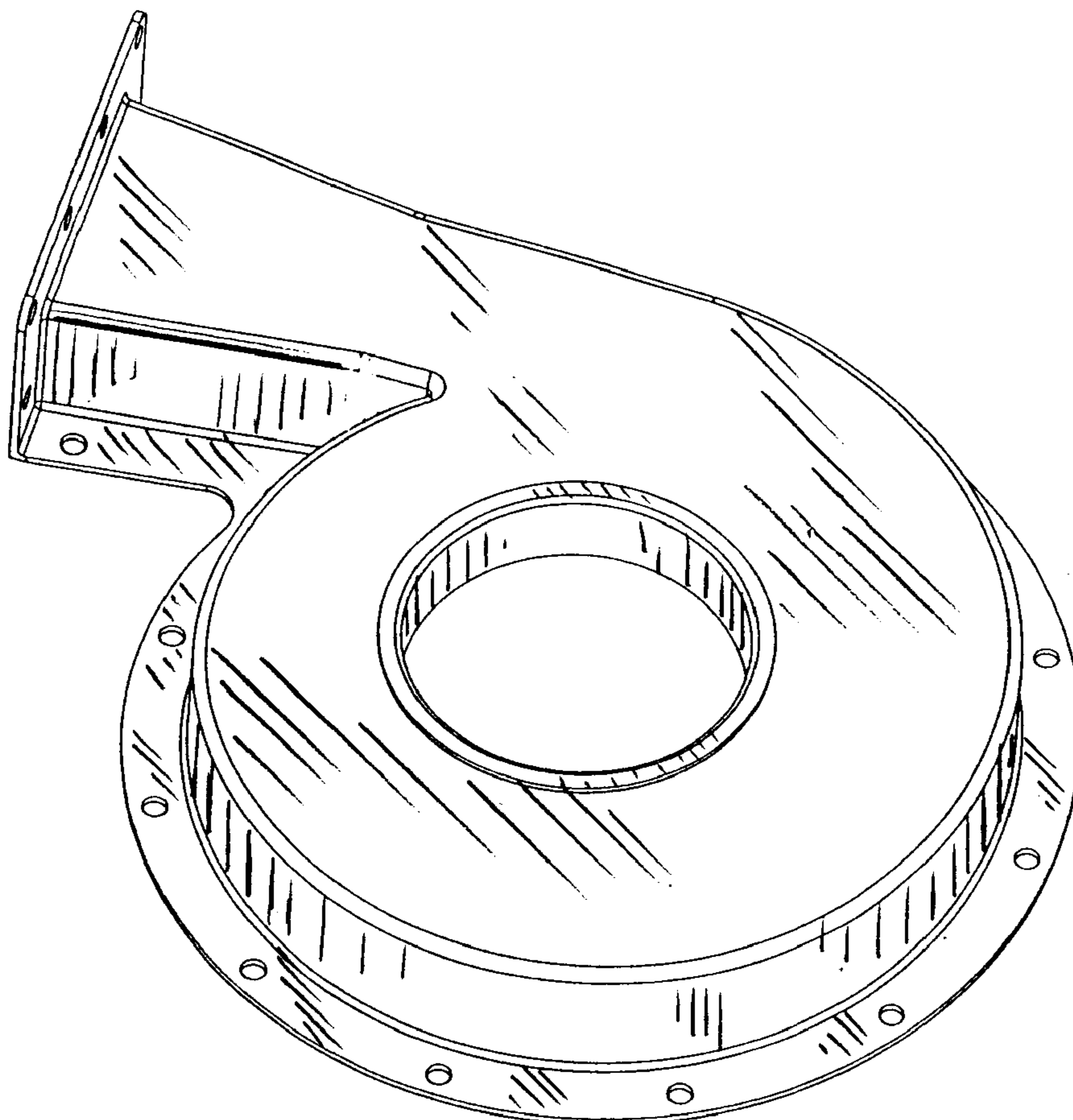

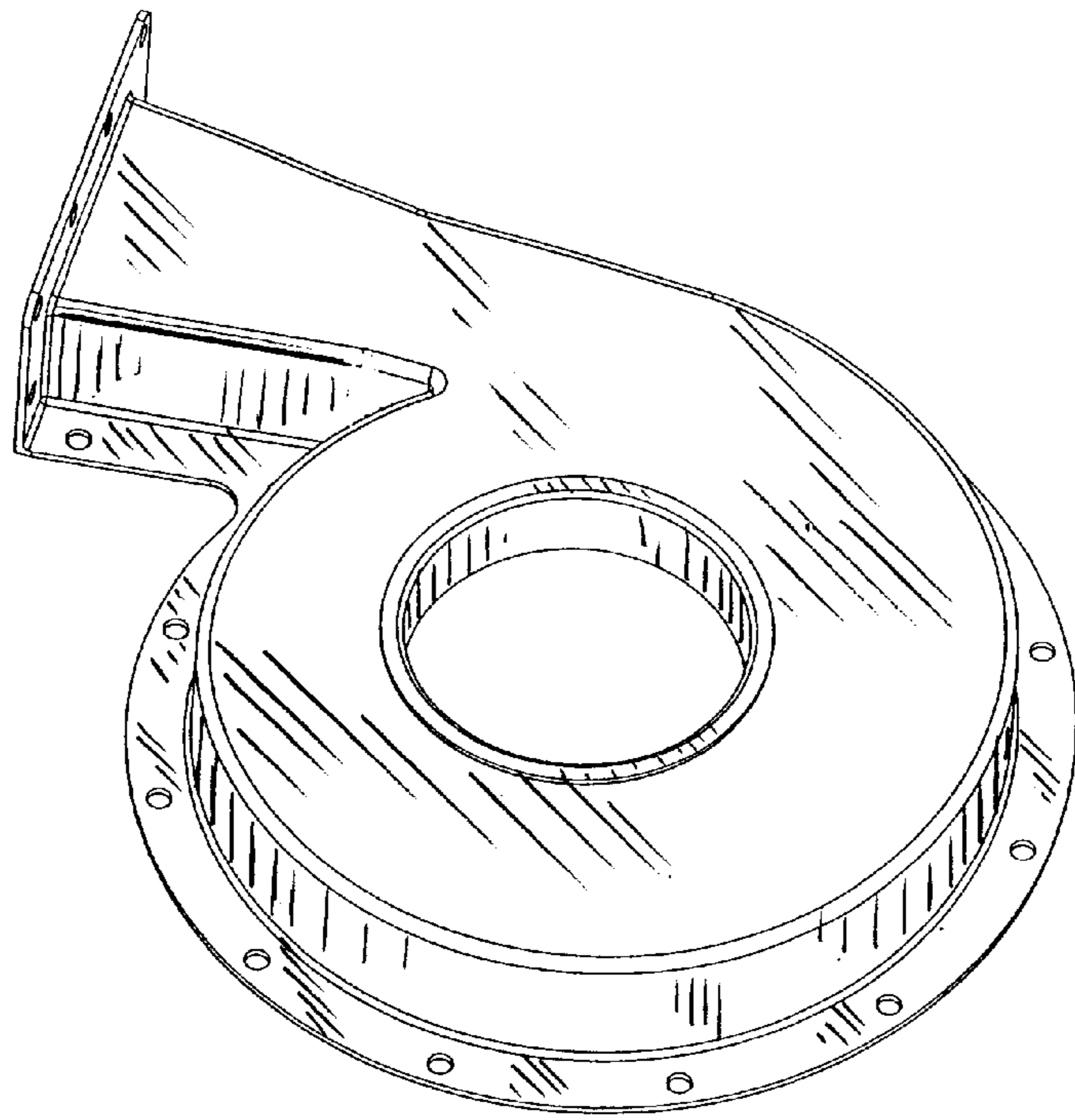

FIG 1

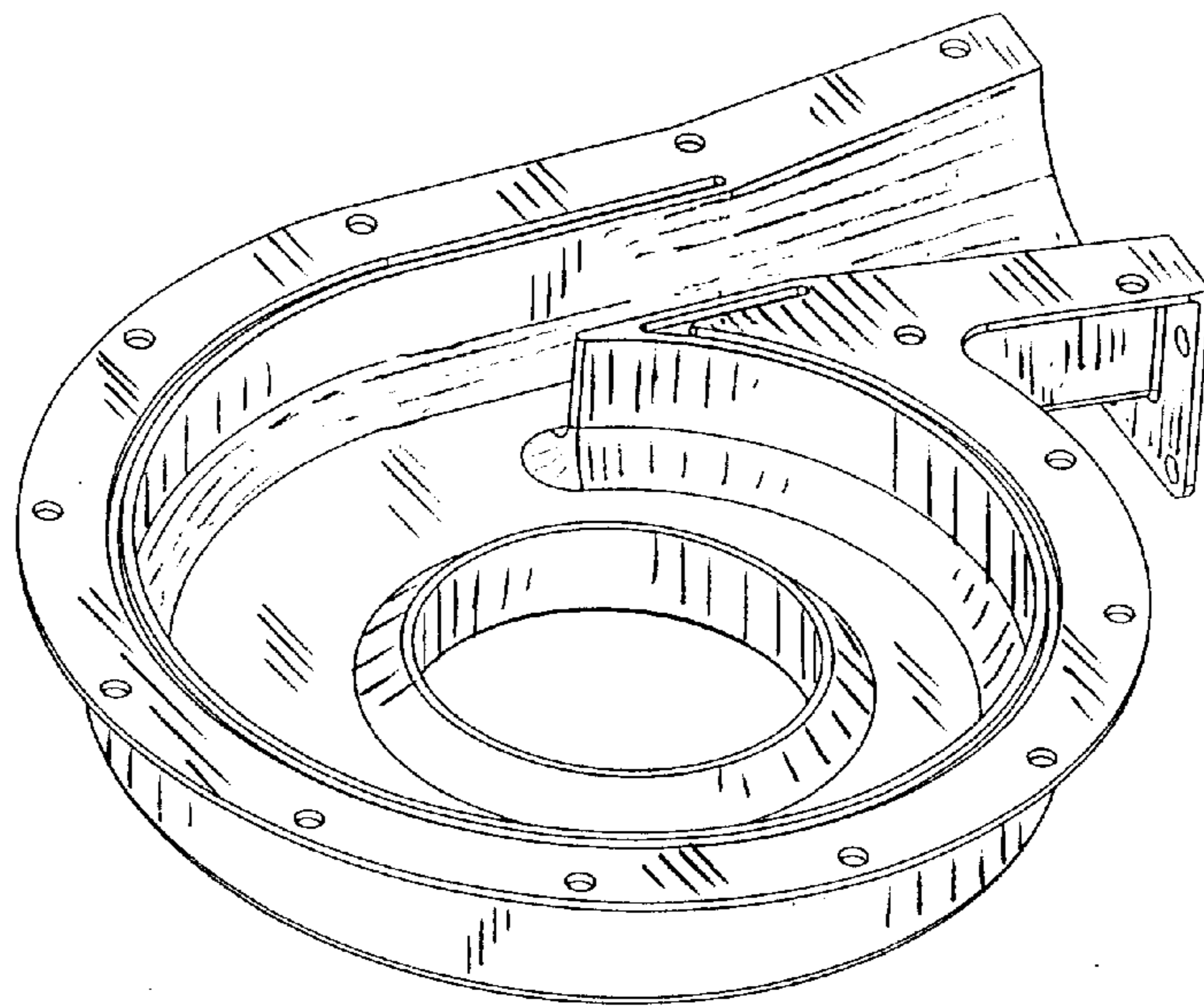

FIG. 2

FIG. 3

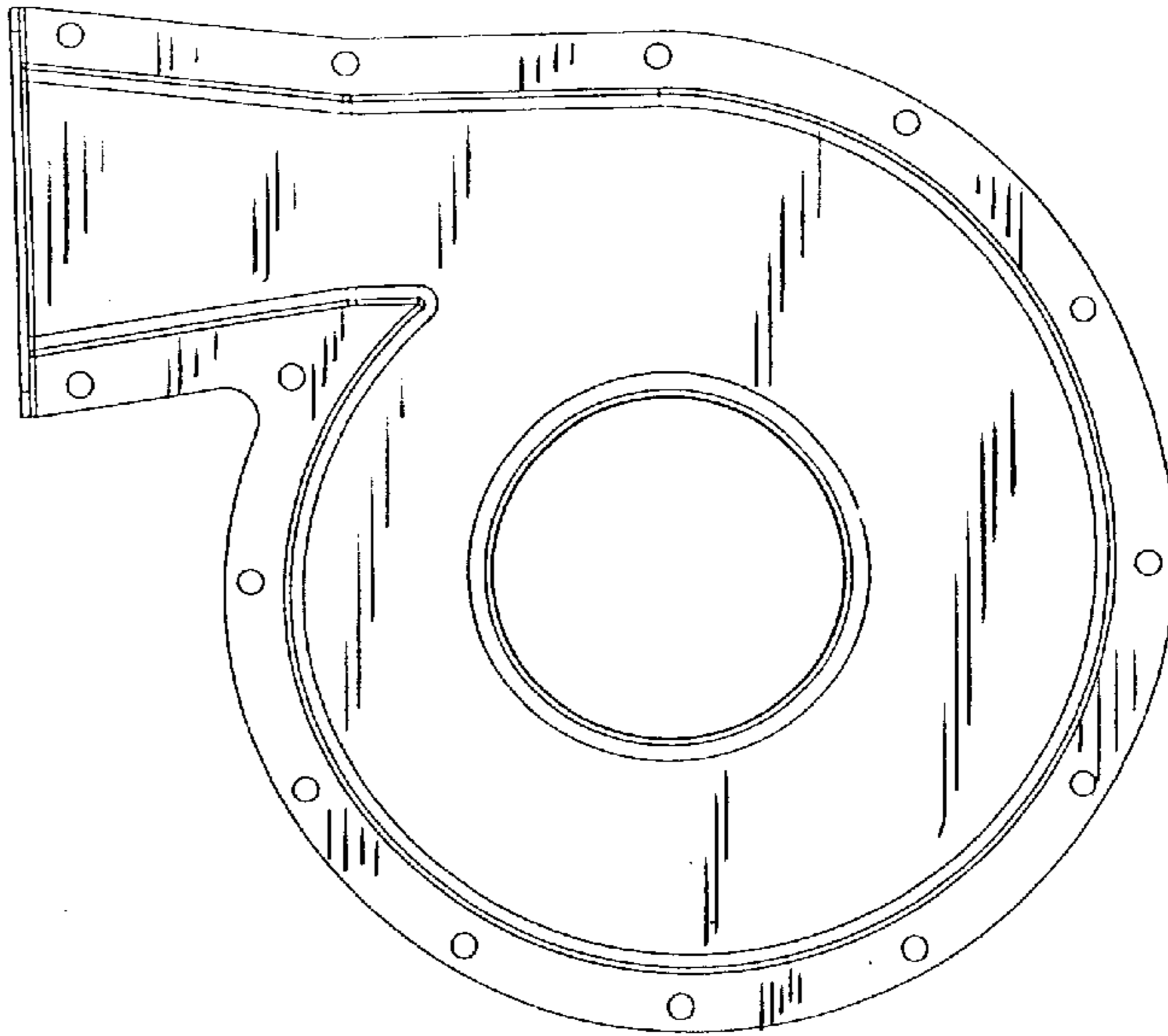

FIG. 4

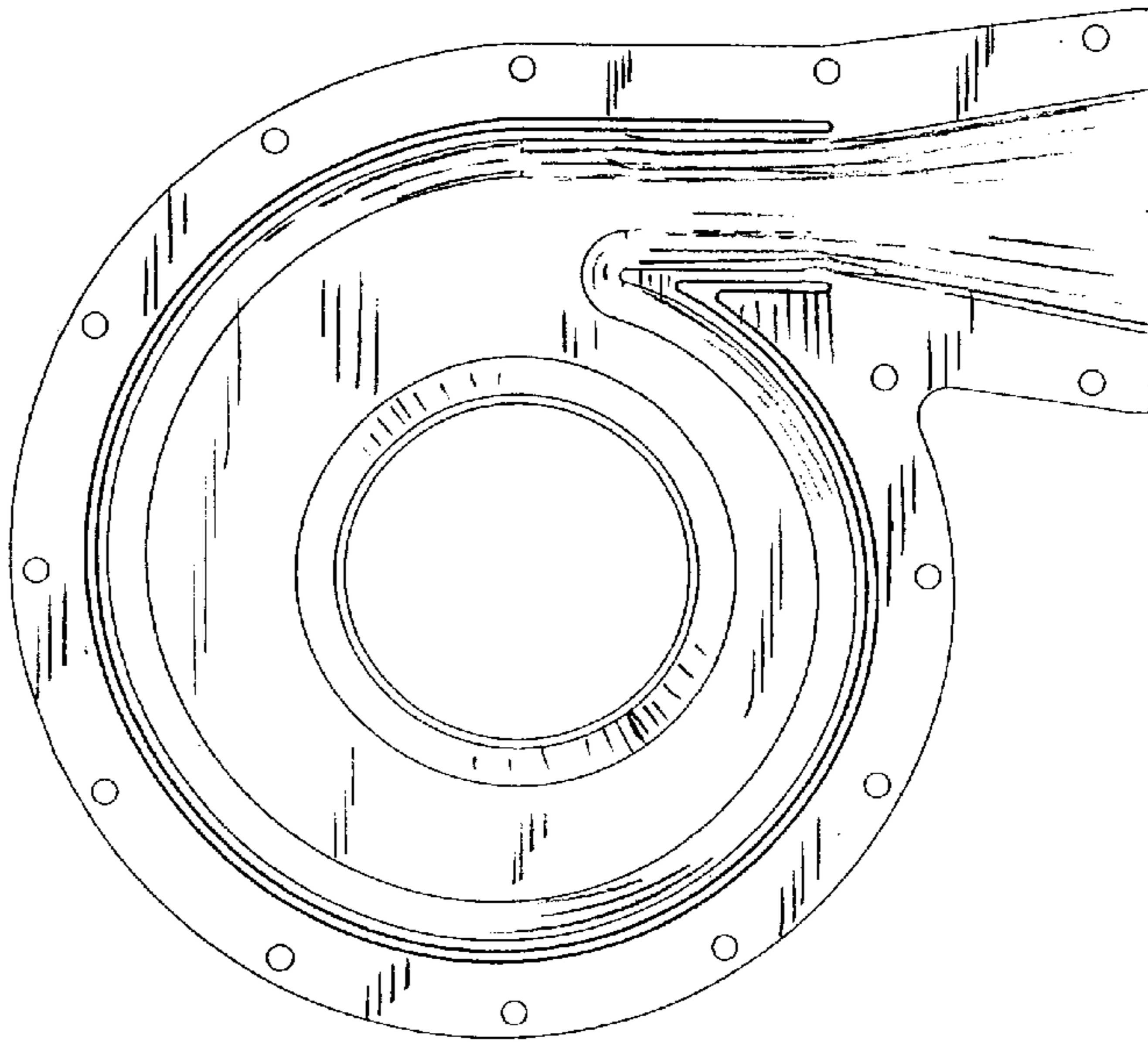

FIG. 5

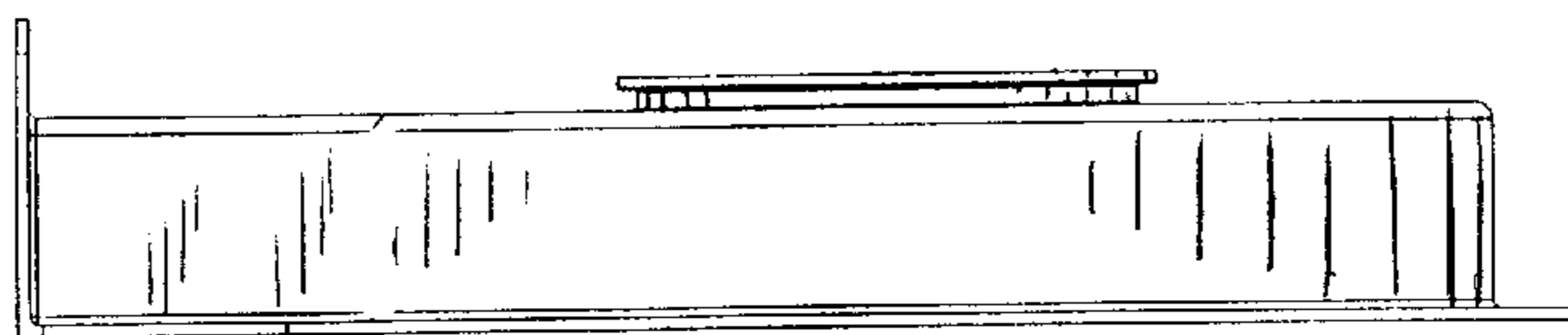
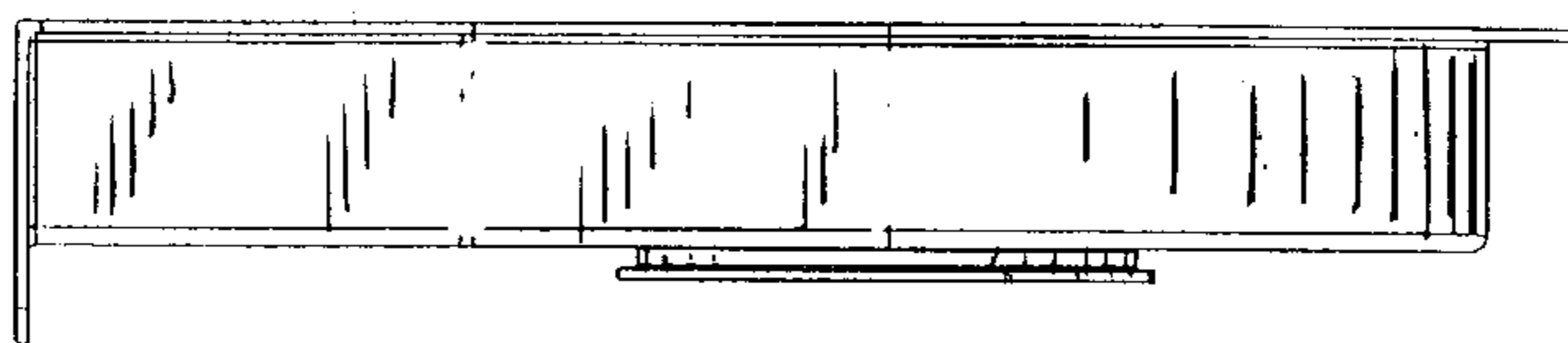

FIG. 6



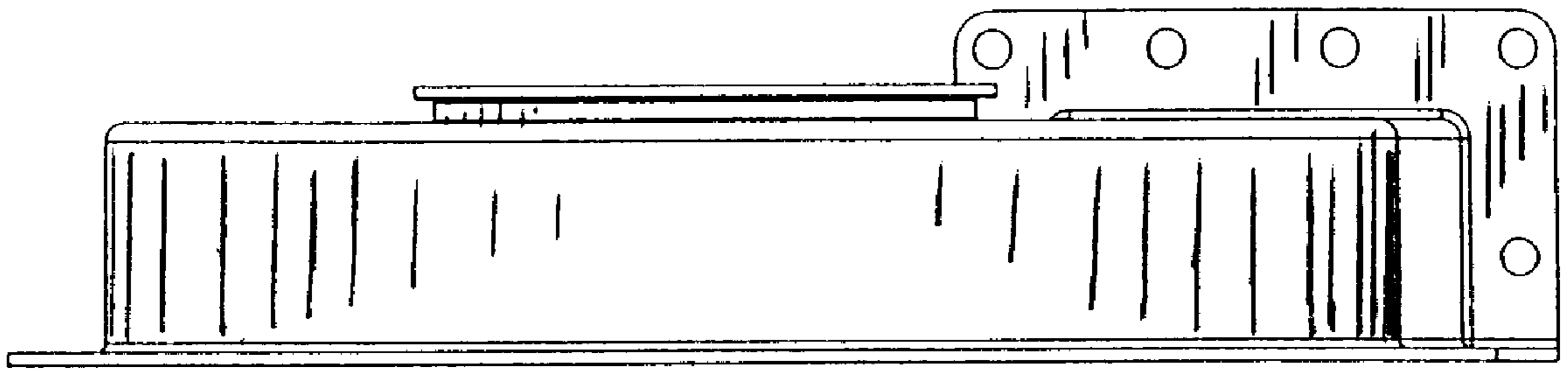

FIG. 7

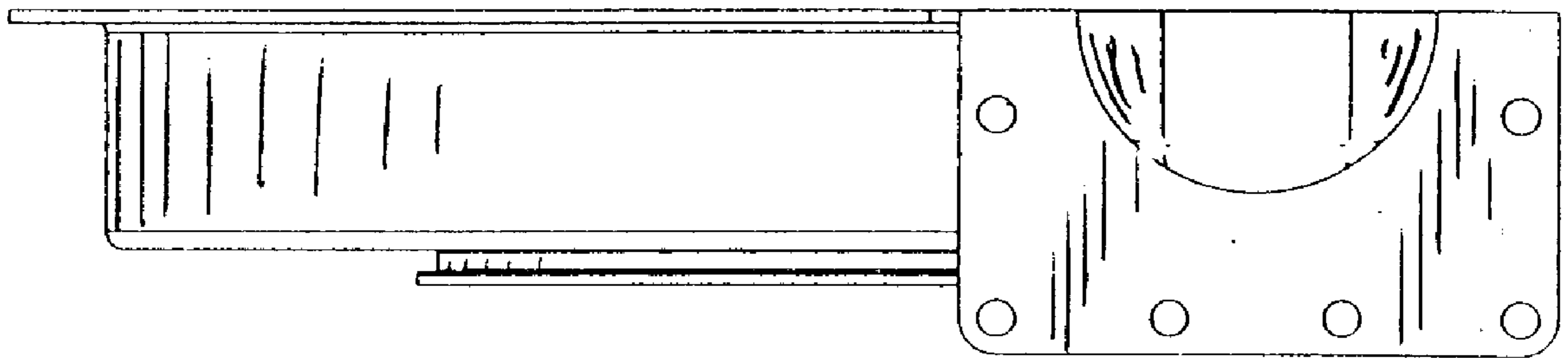

FIG. 8

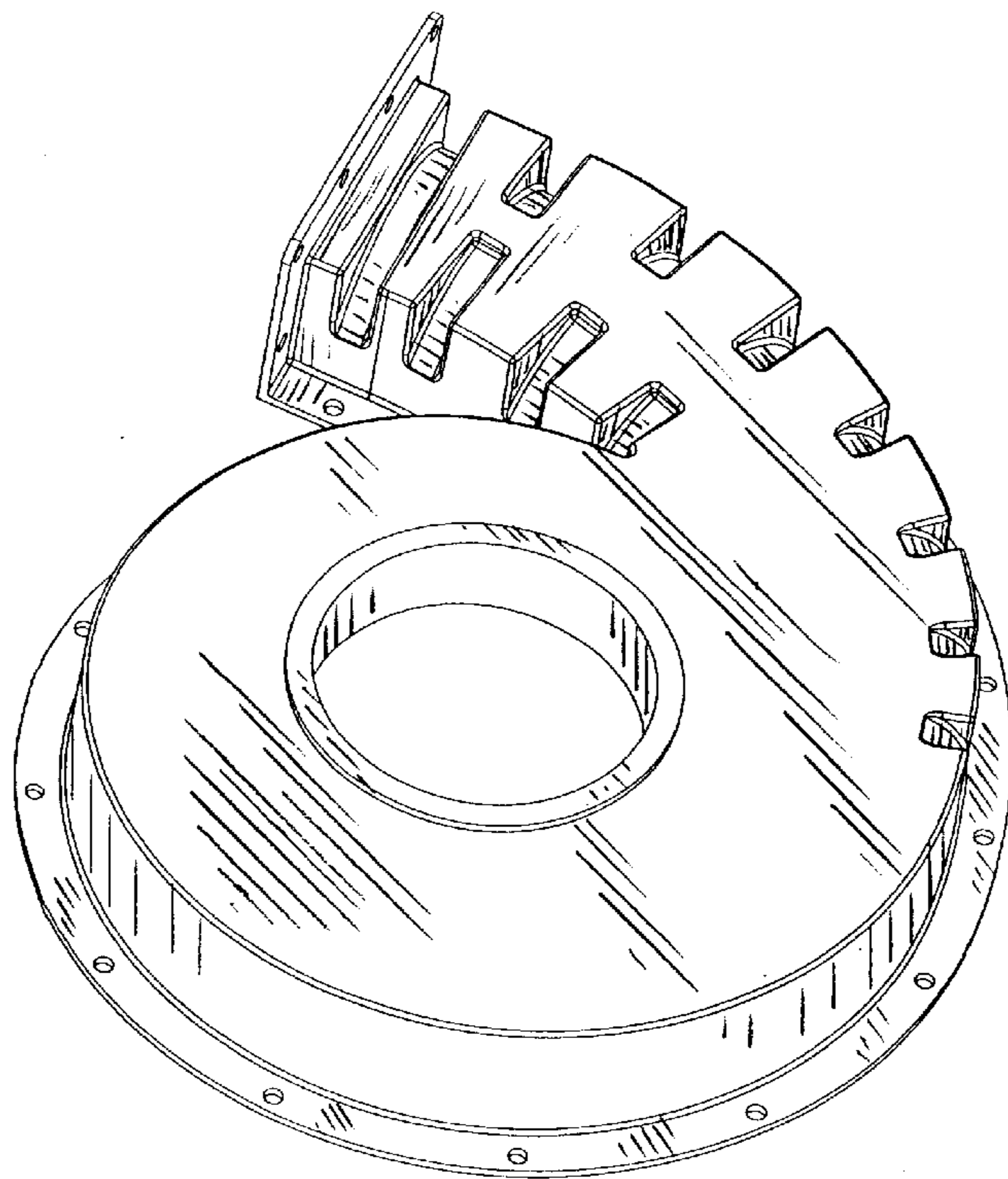

FIG. 9

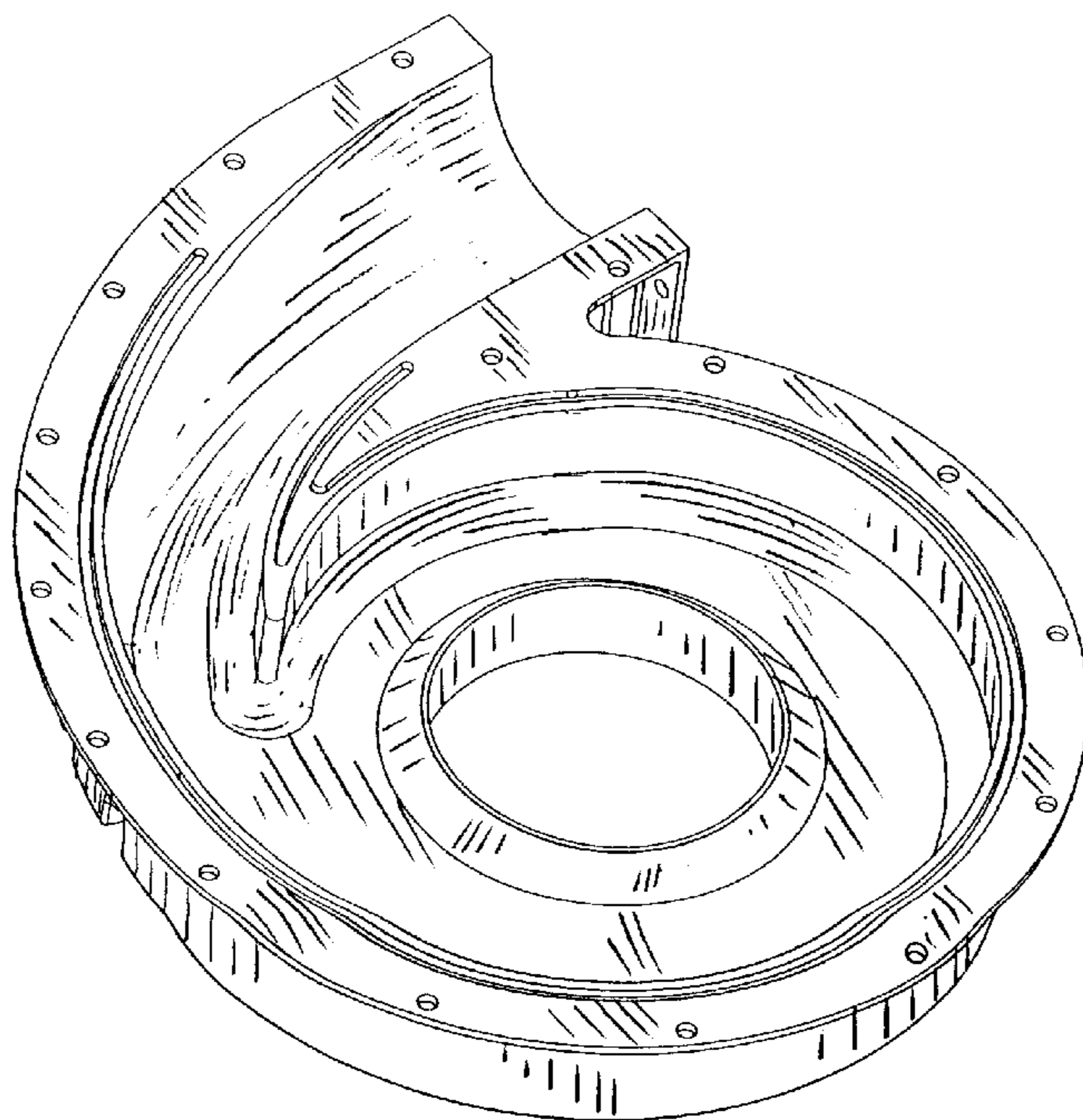

FIG. 10

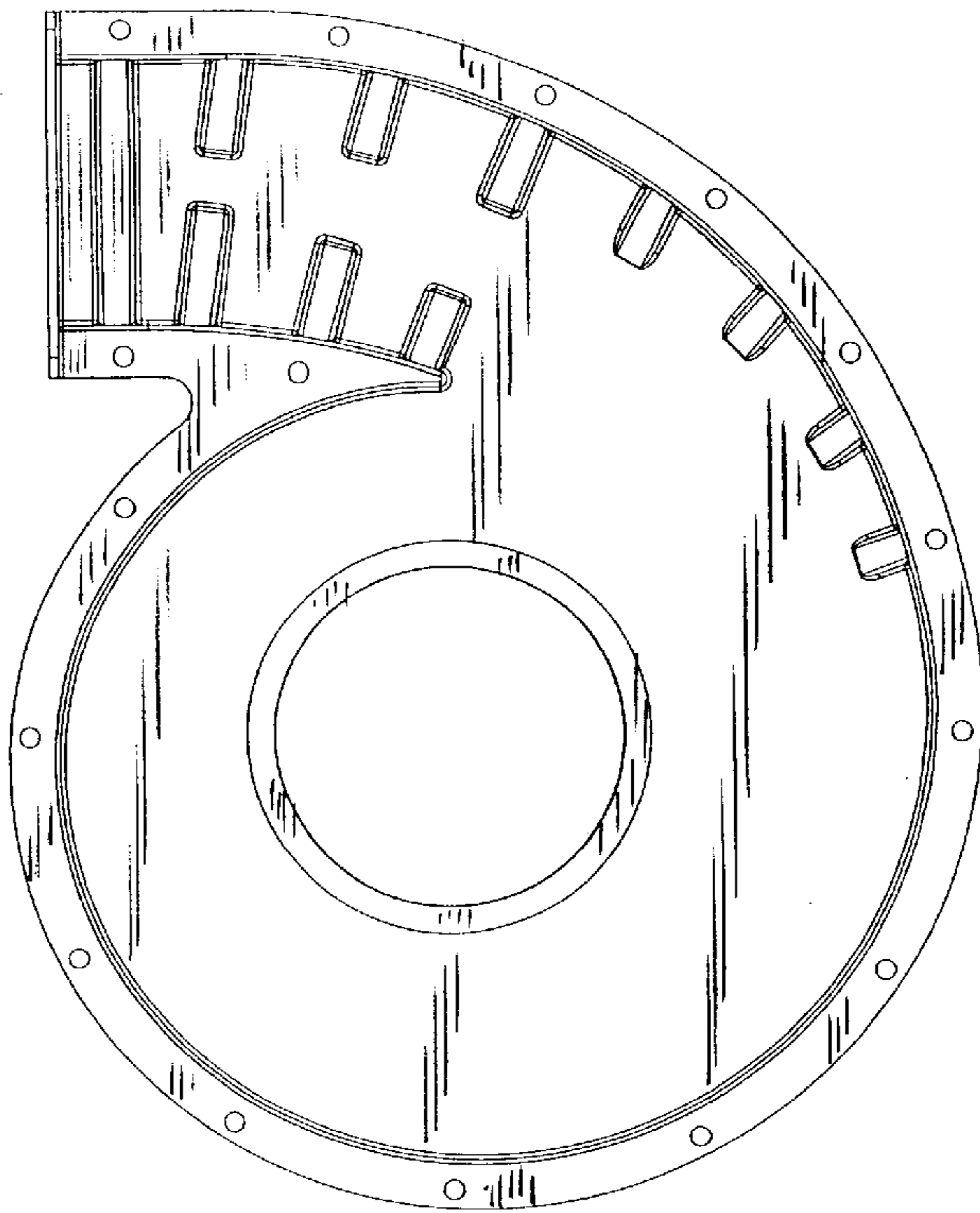

FIG. 11

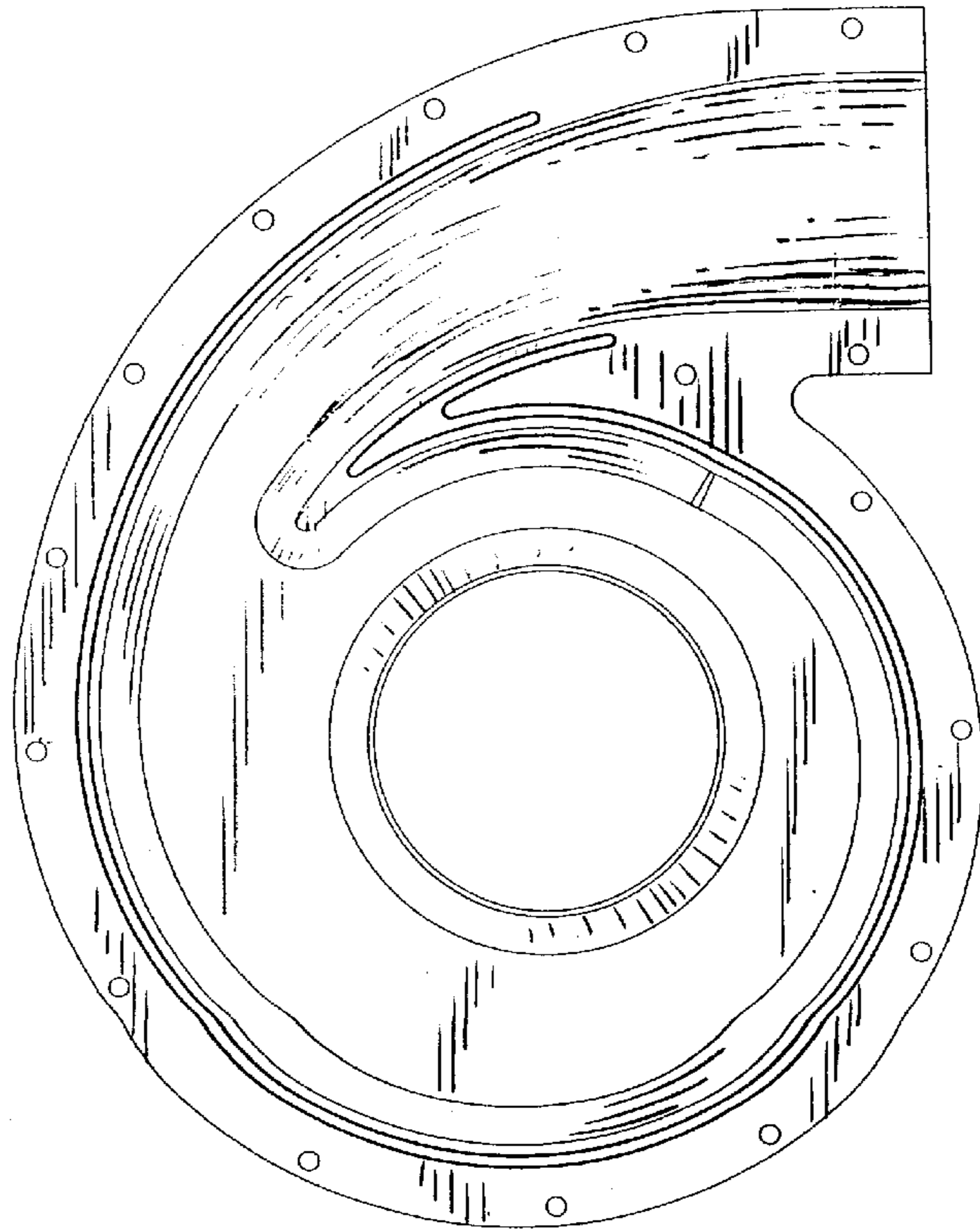

FIG. 12

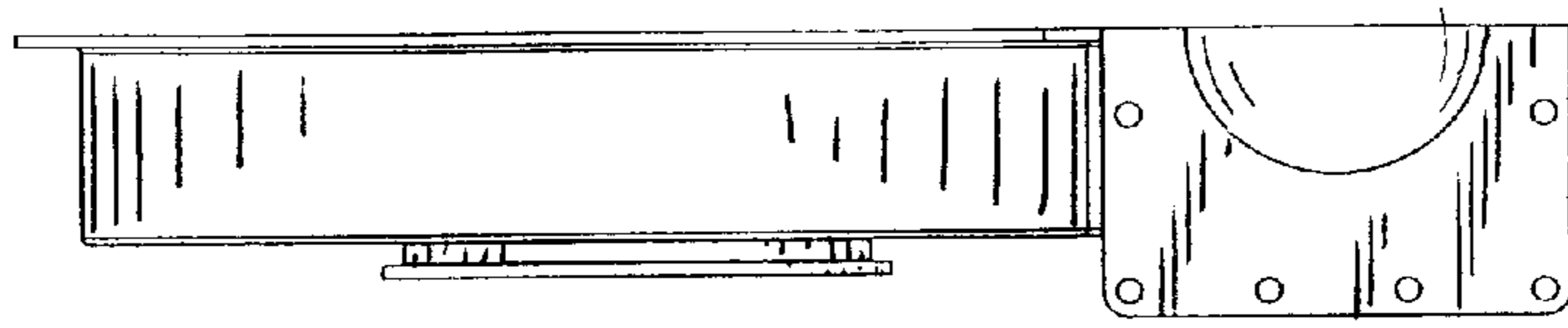

FIG. 13

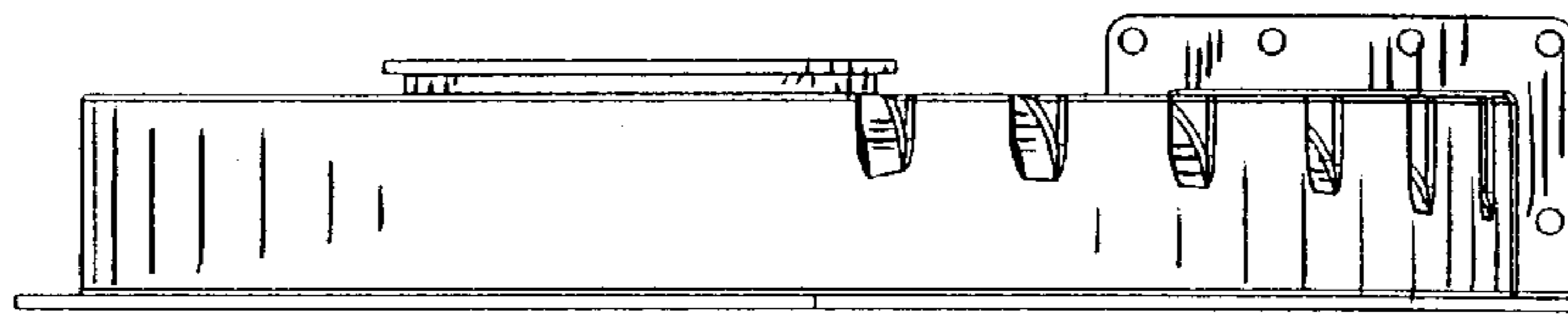

FIG. 14

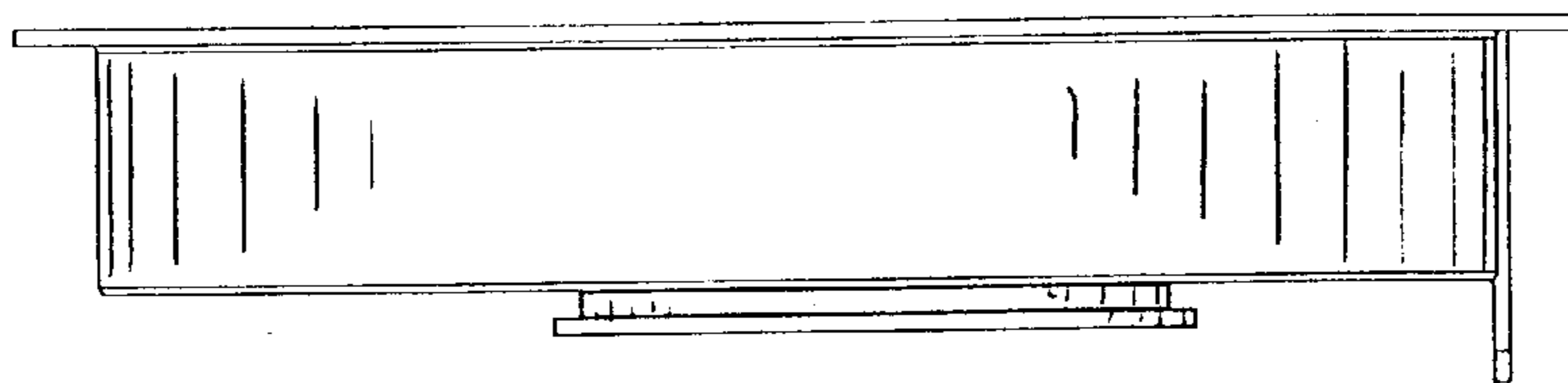

FIG. 15

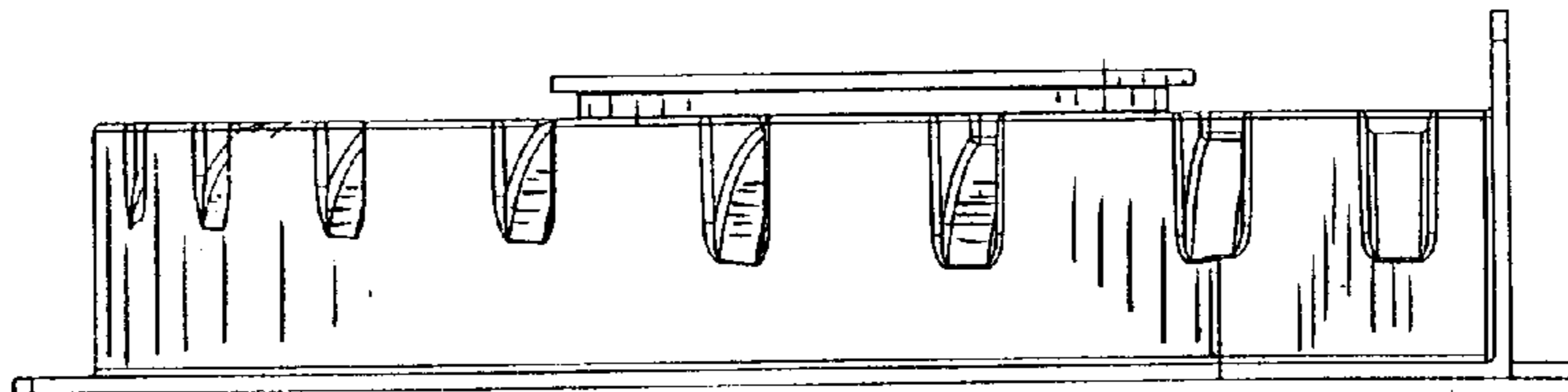

FIG. 16