



US00D415454S

United States Patent [19]
Blankenship et al.

[11] **Patent Number: Des. 415,454**

[45] **Date of Patent: ** Oct. 19, 1999**

[54] **TIRE TREAD**

Attorney, Agent, or Firm—D. A. Thomas

[75] Inventors: **Leonard F. Blankenship**, Sterling;
James G. Guspodin, Akron, both of
Ohio

[57] **CLAIM**

The ornamental design for a tire tread, as shown and described.

[73] Assignee: **Bridgestone/Firestone Research, Inc.**,
Akron, Ohio

DESCRIPTION

[**] Term: **14 Years**

FIG. 1 is a side perspective view of a tire tread showing our new design, it being understood that the tread pattern is repeated throughout the circumference of the tire tread, the opposite side being the same as that shown;

[21] Appl. No.: **29/094,938**

FIG. 2 is a front elevational view thereof;

[22] Filed: **Oct. 14, 1998**

FIG. 3 is a side elevational view of the right side thereof, the opposite side being identical thereto; and,

[51] **LOC (6) Cl.** **12-15**

[52] **U.S. Cl.** **D12/147**

[58] **Field of Search** D12/136-152;
152/209.1, 209.8, 209.9, 209.11, 209.12,
209.13, 209.16, 209.18, 209.19, 209.21,
209.28, 900, 901, 902, 903

FIG. 4 is an enlarged fragmentary front elevational view thereof.

[56] **References Cited**

The dark stippled surface shading represents the recessed portion of the tread grooves, having a depth as best shown in FIG. 2; the broken lines defining the inner bead of the sidewall and the peripheral boundary between the tire tread and the sidewall are for illustrative purposes only and form no part of the claimed design.

U.S. PATENT DOCUMENTS

D. 350,095 8/1994 Anderson et al. D12/147

OTHER PUBLICATIONS

Dayton Daytona Metric Radial Tire, 1997 Tread Design Guide, p. 23.

Primary Examiner—Robert M. Spear

1 Claim, 4 Drawing Sheets

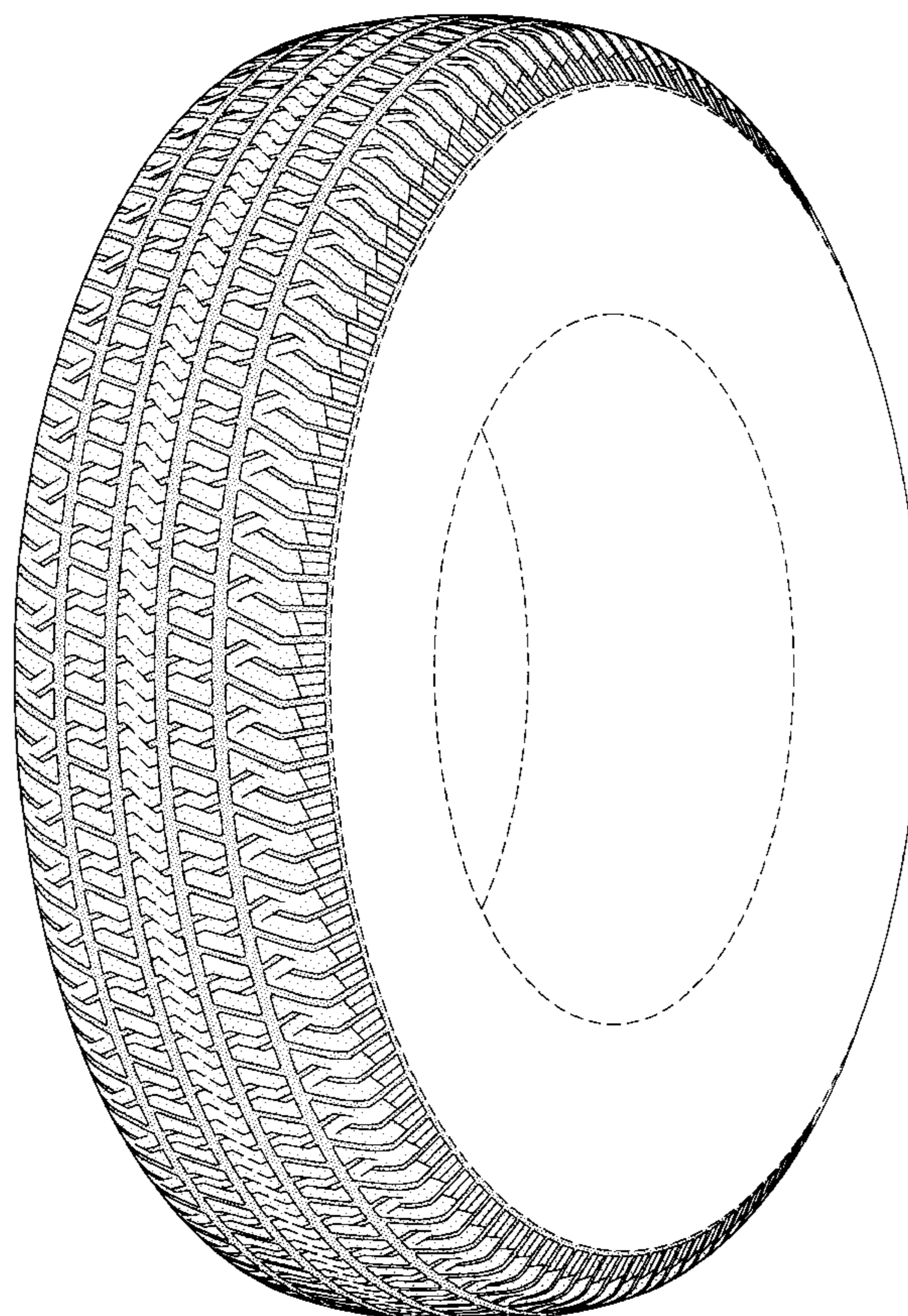

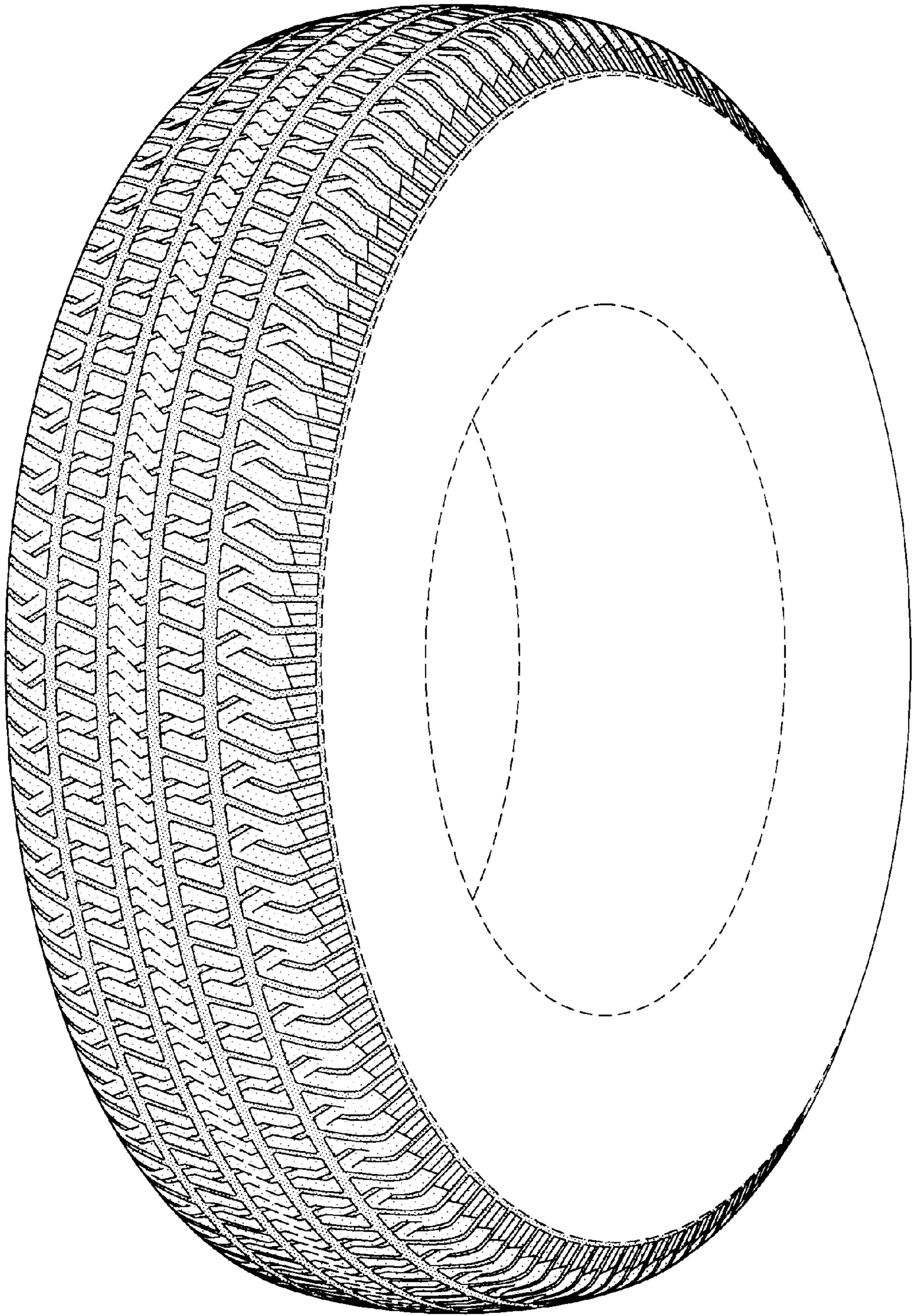

FIG-1

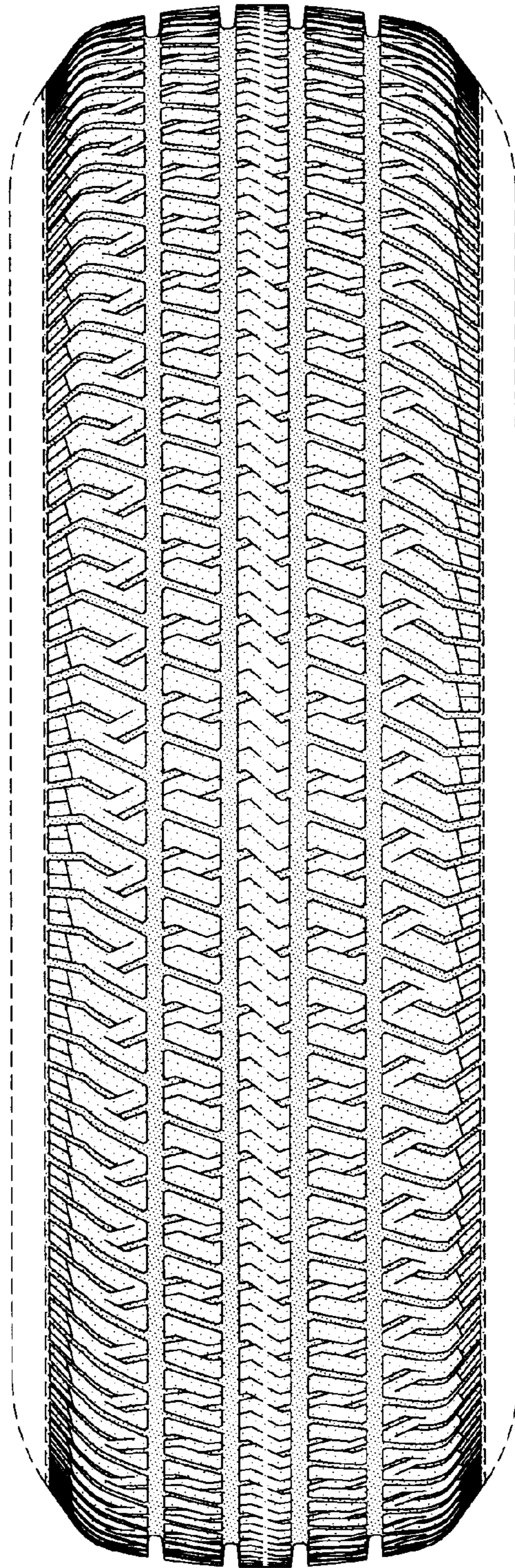

FIG-2

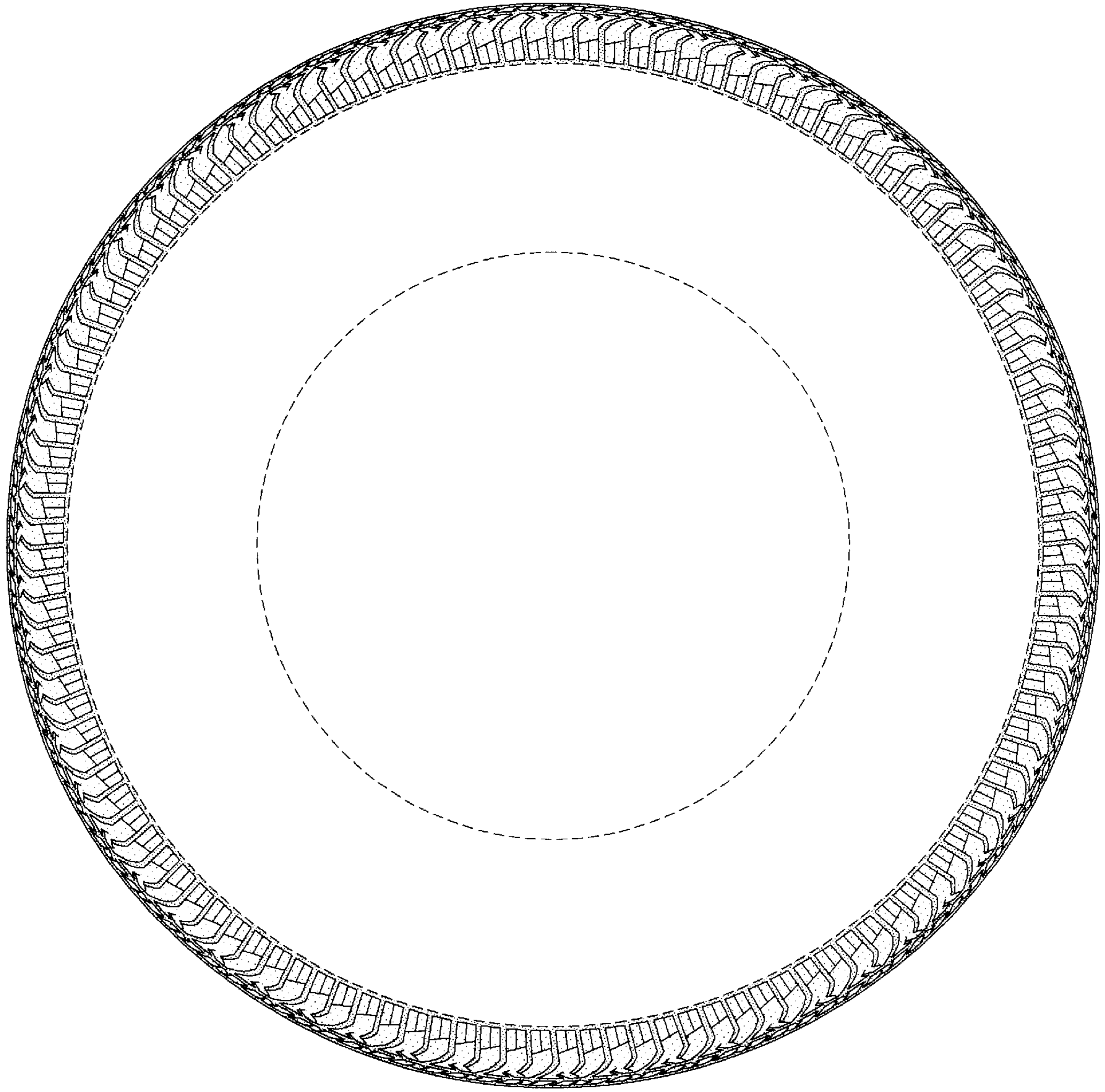

FIG-3

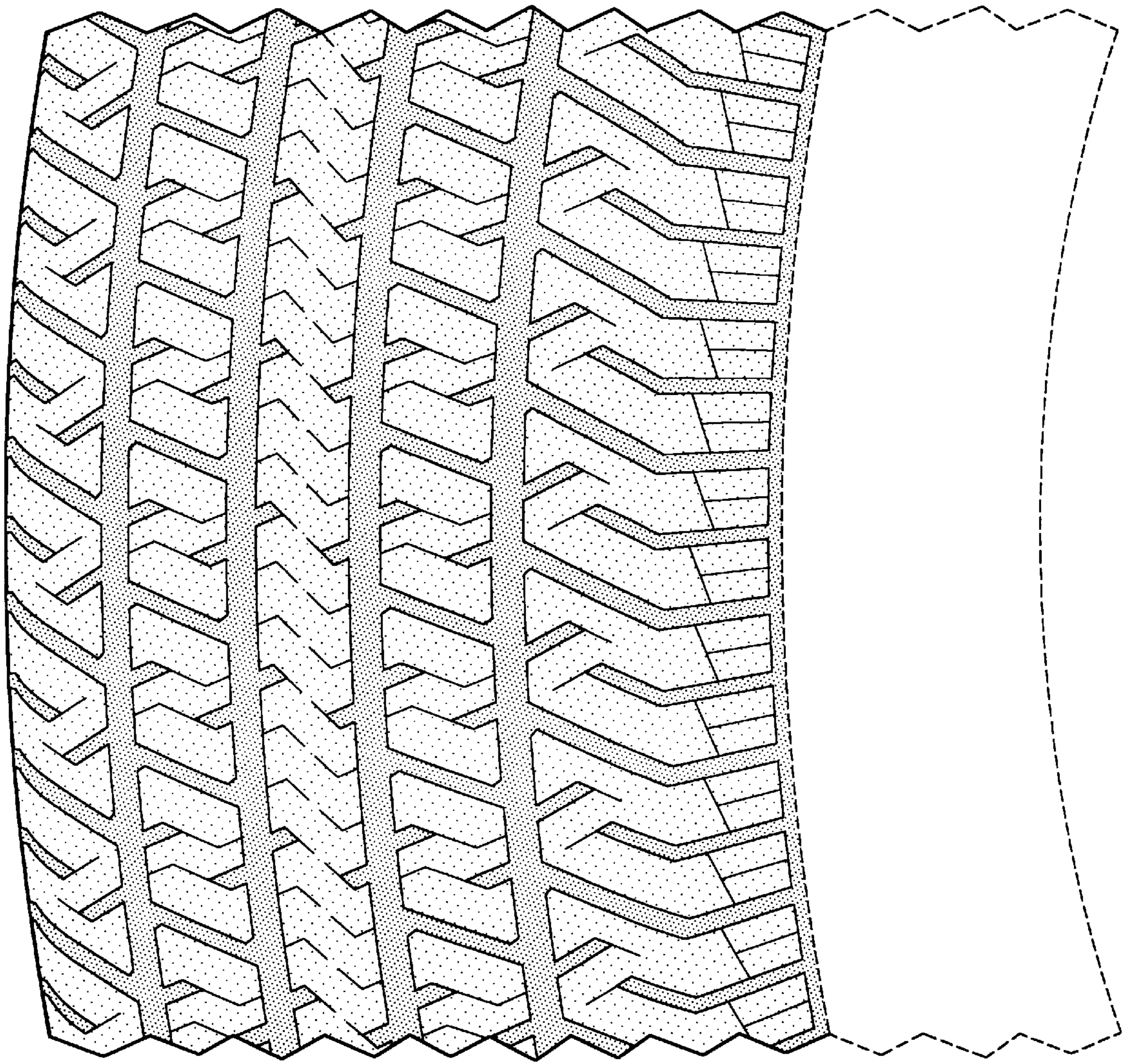

FIG-4