



US00D415287S

# United States Patent [19]

Davis

[11] Patent Number: Des. 415,287

[45] Date of Patent: \*\* \*Oct. 12, 1999

[54] RAIL

[75] Inventor: Harry H. Davis, Mooresville, N.C.

[73] Assignee: L.B. Plastics Limited, Darby, United Kingdom

[\*] Notice: This patent is subject to a terminal disclaimer.

[\*\*] Term: 14 Years

[21] Appl. No.: 29/092,109

[22] Filed: Aug. 12, 1998

[51] LOC (6) Cl. .... 25-02

[52] U.S. Cl. .... D25/38

[58] Field of Search ..... D25/38; 256/19, 256/34, 59, 21-22, 65

### [56] References Cited

#### U.S. PATENT DOCUMENTS

D. 344,807	3/1994	Abbatichio	.....	D25/38
3,313,527	4/1967	Eriksson	.....	256/21
3,506,243	4/1970	Seiler	.....	256/59
4,421,302	12/1983	Grimm et al.	.....	256/65
4,451,025	5/1984	Spera	.....	256/22

Primary Examiner—Doris Clark

Attorney, Agent, or Firm—Adams Law Firm, P.A.

### [57] CLAIM

I claim the ornamental design for a rail, as shown and described.

### DESCRIPTION

FIG. 1 is a fragmentary perspective view of the rail with its interior elements and associated environmental structure shown in phantom, the interior elements and environmental structure forming no part of the claimed design, the rail being broken away on one end to disclose indefinite length; FIG. 2 is a fragmentary perspective view of the rail with its interior elements shown in phantom, the interior elements forming no part of the claimed design, the rail being broken away on one end to disclose indefinite length; FIG. 3 is an end view of the rail with its interior elements shown in phantom, the interior elements forming no part of the claimed design, the rail being broken away on one end to disclose indefinite length; FIG. 4 is a fragmentary side view of the rail, the opposite side being a mirror image thereof, the rail being broken away on one end to disclose indefinite length; FIG. 5 is a fragmentary top plan view thereof, the rail being broken away on one end to disclose indefinite length; and, FIG. 6 is a fragmentary bottom plan view thereof, the rail being broken away on one end to disclose indefinite length.

1 Claim, 4 Drawing Sheets

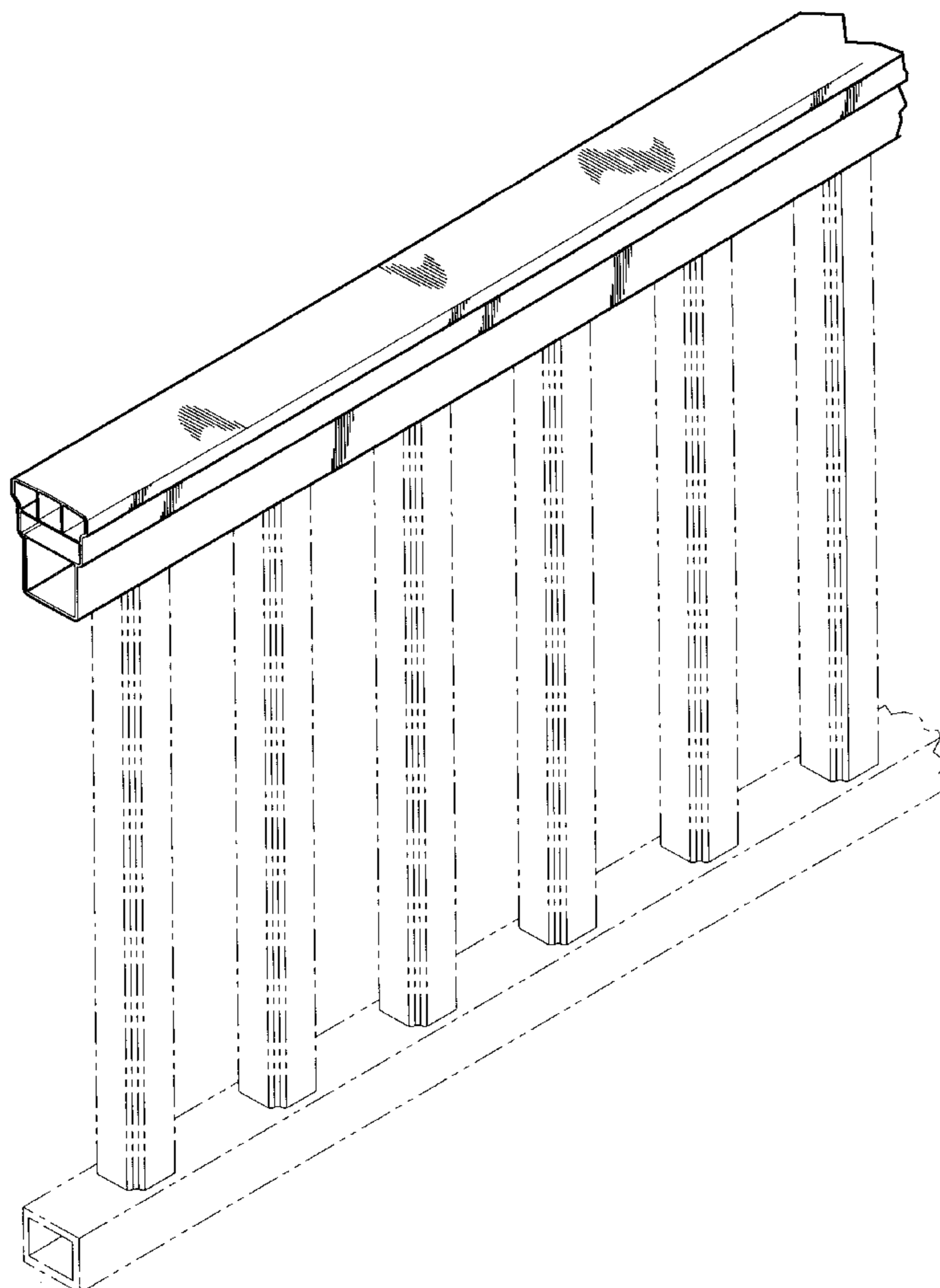

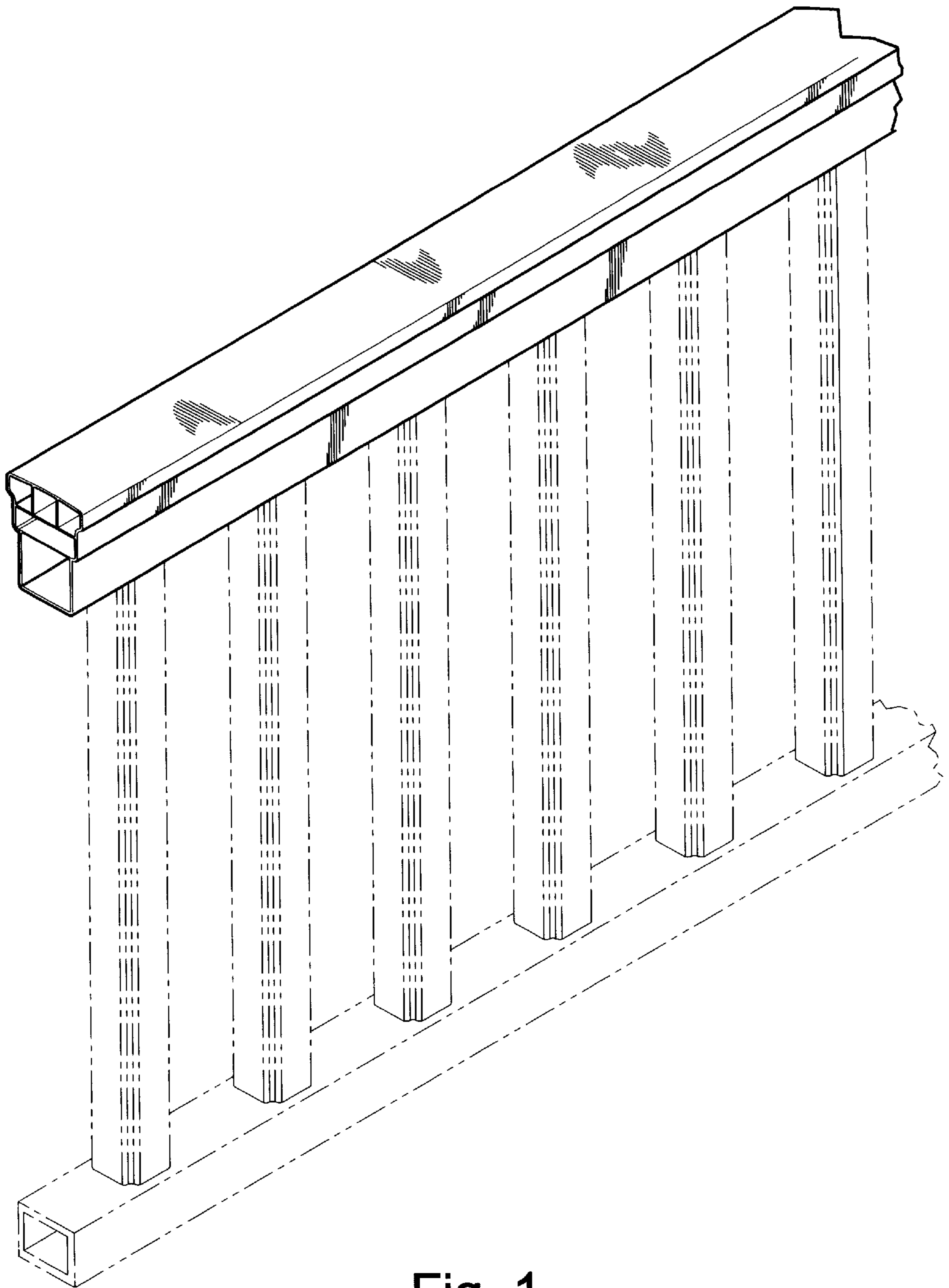

Fig. 1

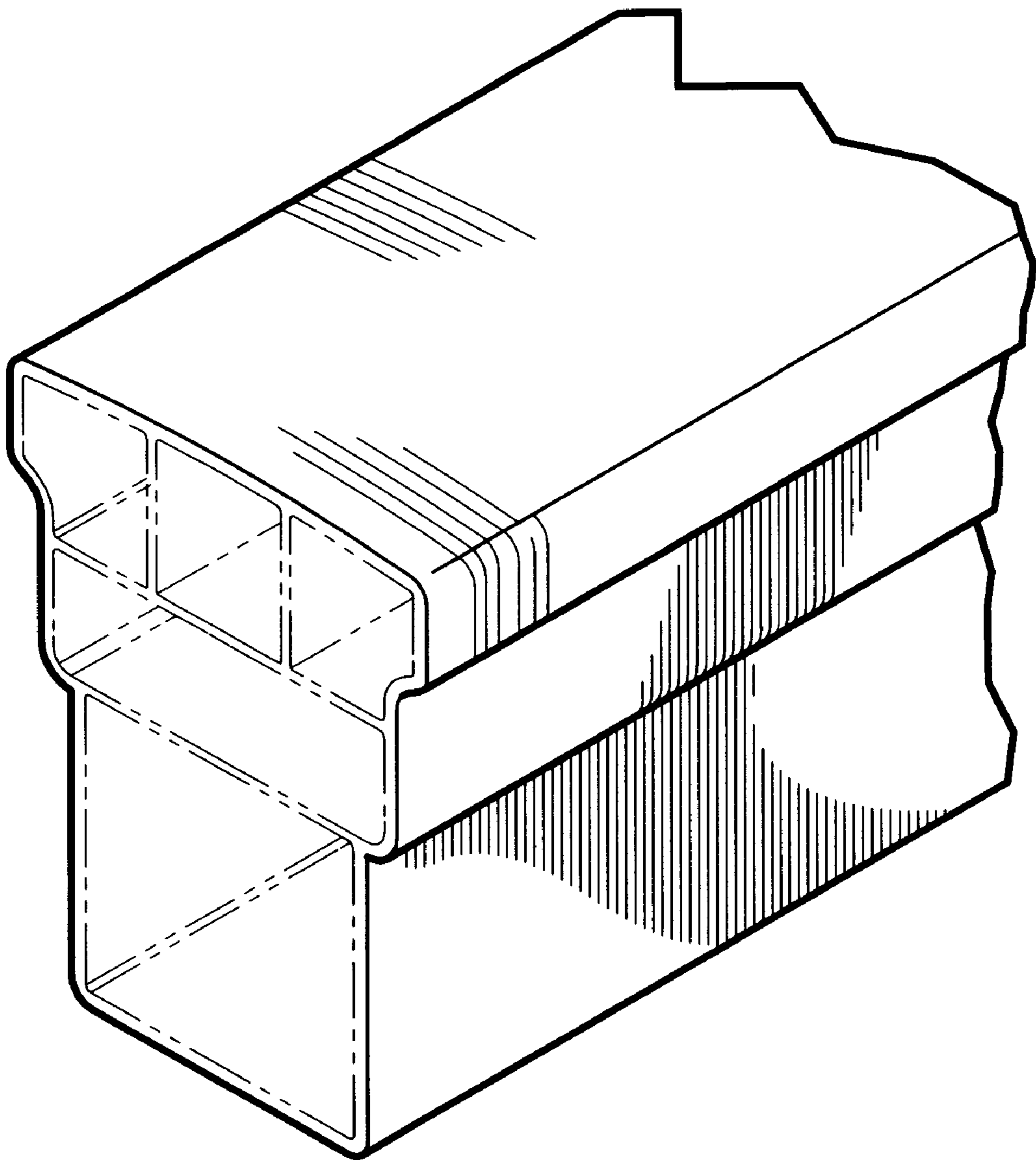

Fig. 2

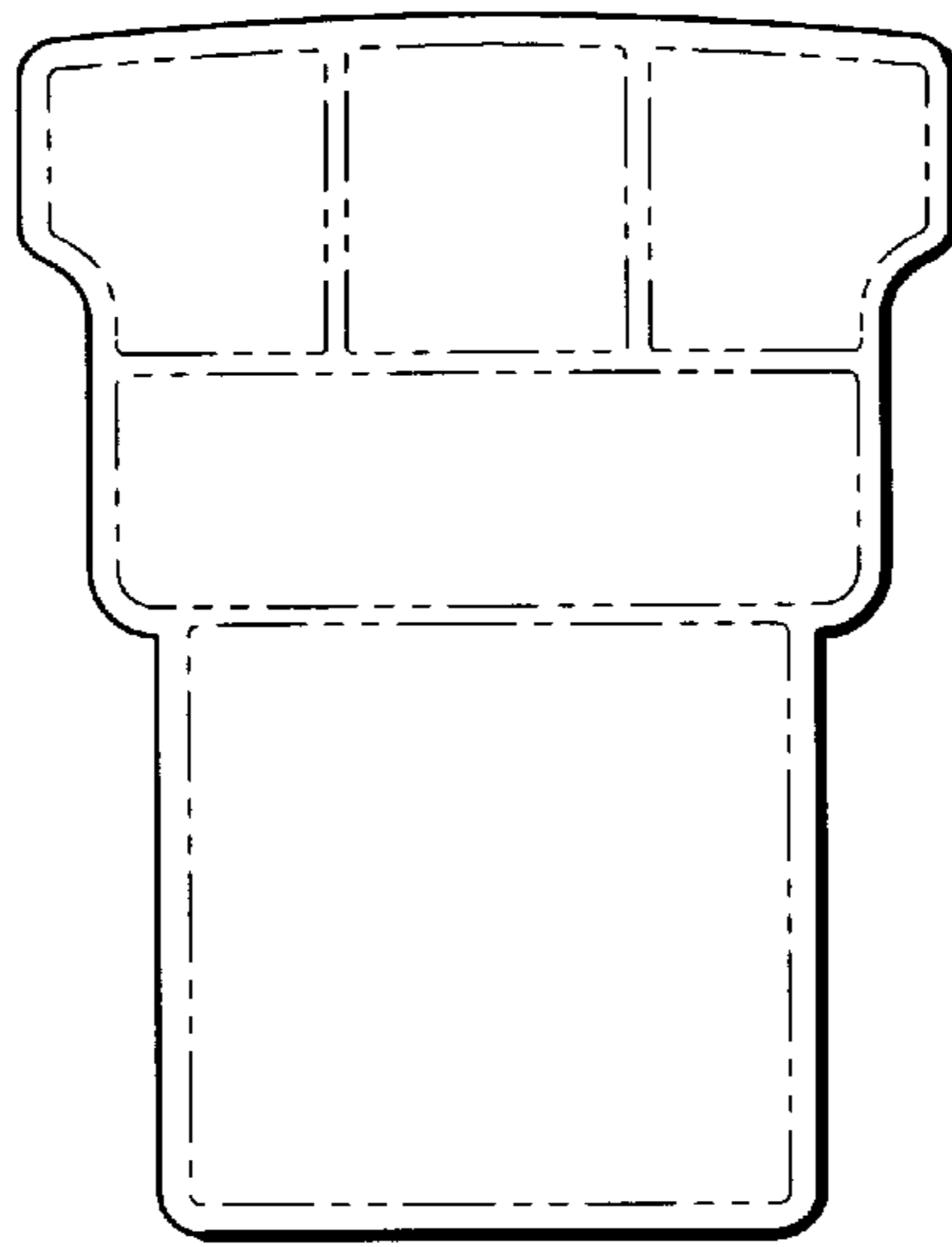

Fig. 3

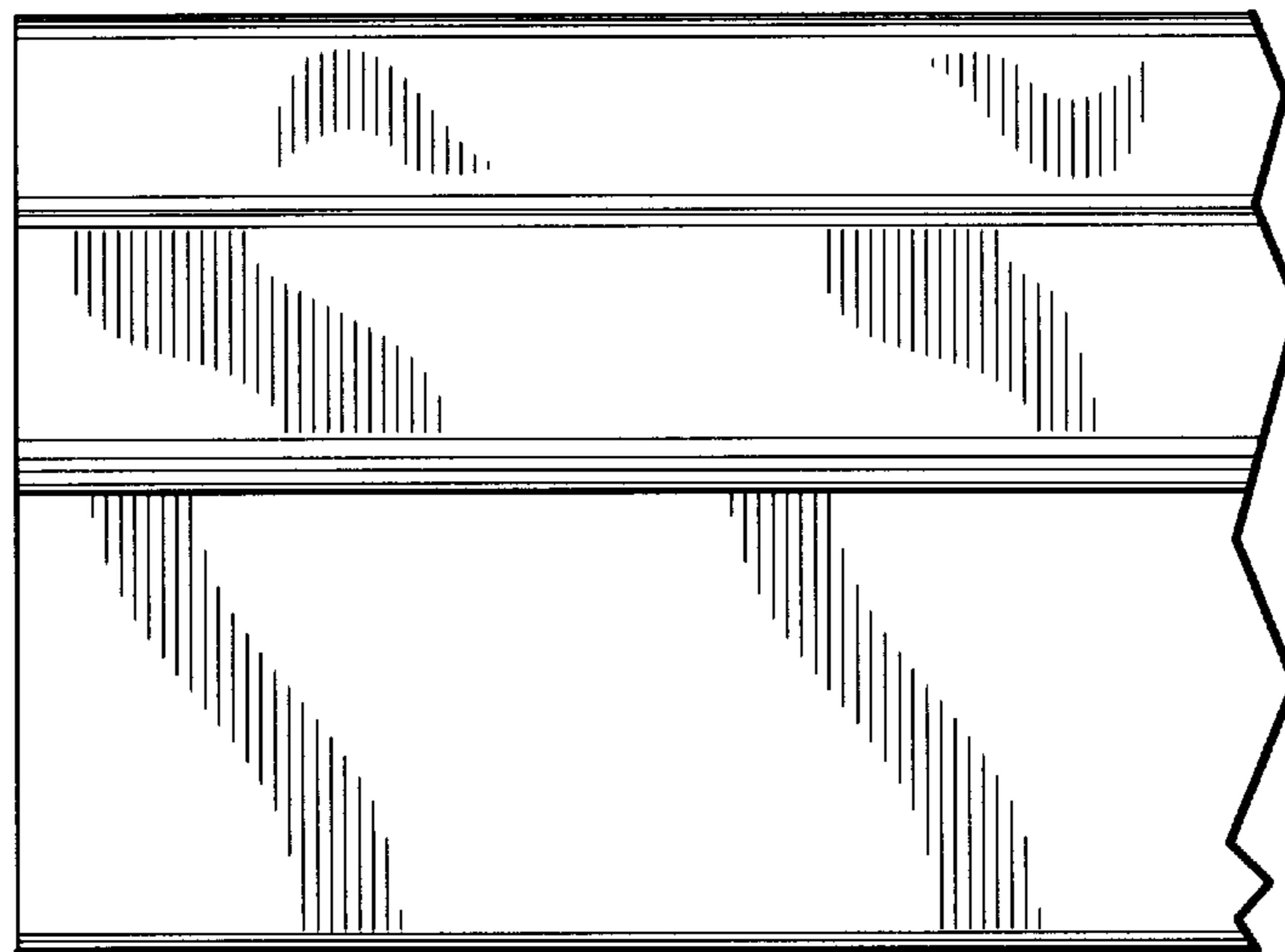

Fig. 4

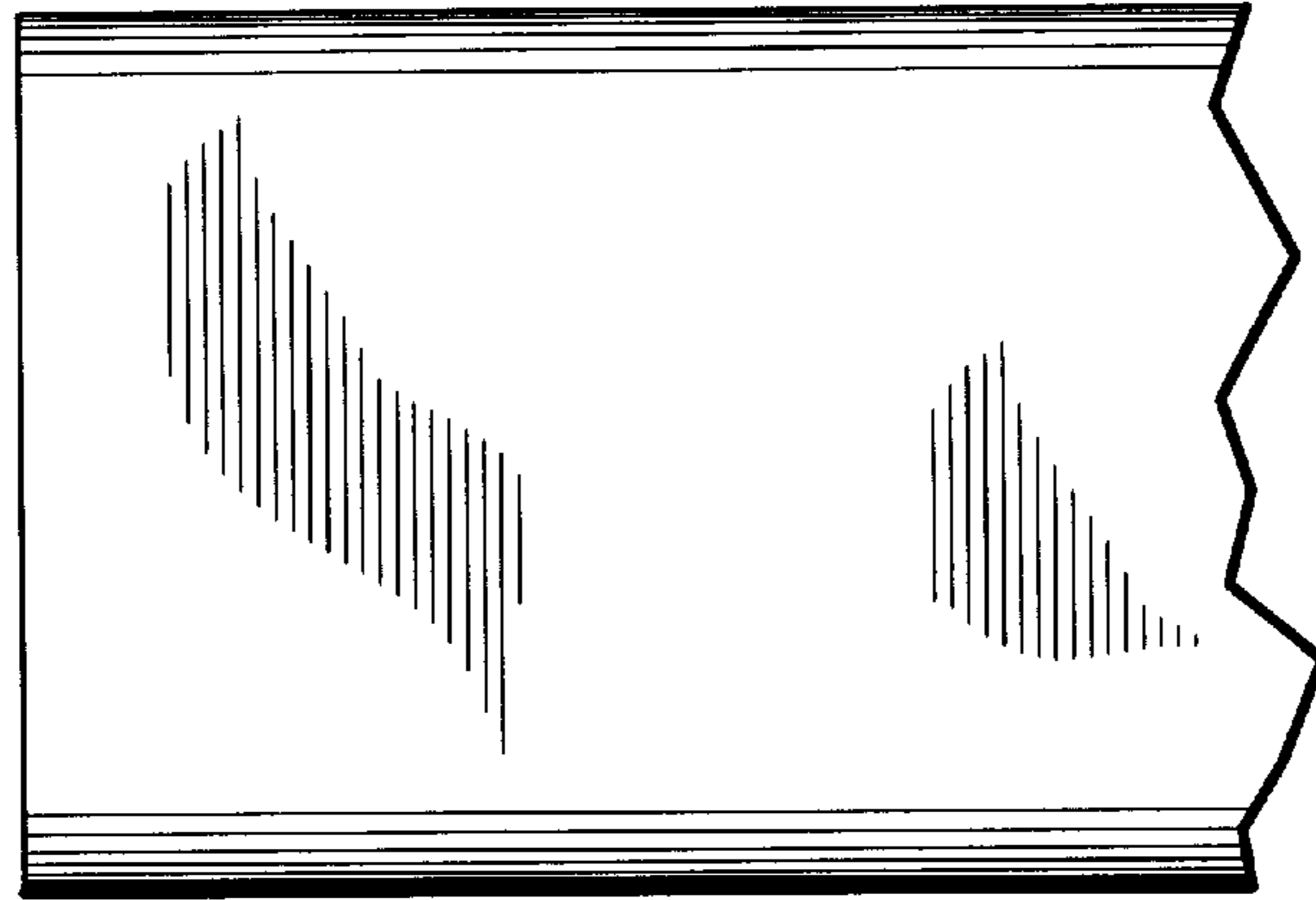

Fig. 5

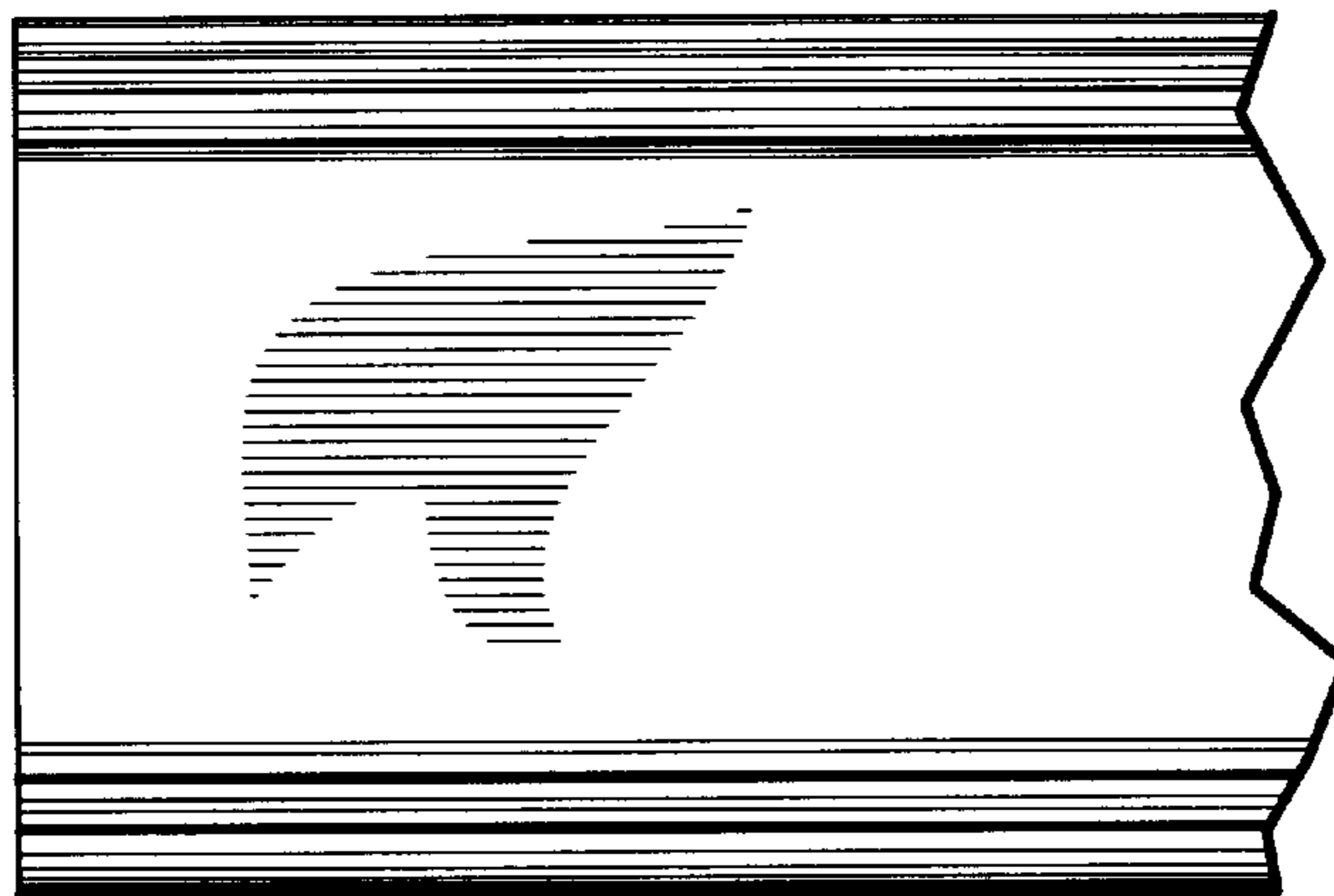

Fig. 6