



US00D414883S

# United States Patent [19]

[11] Patent Number: **Des. 414,883**

Kato et al.

[45] Date of Patent: **\*\* Oct. 5, 1999**

[54] **SELF-BALLASTED COMPACT FLUORESCENT LAMPS**

[75] Inventors: **Masayoshi Kato; Takeshi Matsumura; Shiro Iida**, all of Osaka, Japan

[73] Assignee: **Matsushita Electronics Corporation**, Japan

[\*\*] Term: **14 Years**

[21] Appl. No.: **29/098,281**

[22] Filed: **Dec. 24, 1998**

[51] **LOC (6) Cl.** ..... **26-04**

[52] **U.S. Cl.** ..... **D26/3**

[58] **Field of Search** ..... D26/1, 2, 3, 26; 313/313, 315, 318, 493; 315/53, 56, 57, 58

97301318 2/1998 China .  
 97301533 2/1998 China .  
 97301683 2/1998 China .  
 97301724 2/1998 China .  
 97301725 2/1998 China .  
 97302023 2/1998 China .  
 77685 6/1979 France .  
 DM/003871 6/1984 Hague Agreement .  
 DM/011712 9/1988 Hague Agreement .  
 DM/017294 8/1990 Hague Agreement .  
 DM/042173 7/1997 Hague Agreement .  
 631924 8/1984 Japan .  
 631926 8/1984 Japan .  
 631926 6/1985 Japan .  
 8-255592 10/1996 Japan .  
 2035326 11/1993 United Kingdom .  
 2062441 1/1997 United Kingdom .  
 2066733 6/1997 United Kingdom .

*Primary Examiner*—Marcus A. Jackson  
*Attorney, Agent, or Firm*—Saidman DesignLaw Group

[56] **References Cited**  
 U.S. PATENT DOCUMENTS

D. 291,358 8/1987 Witte ..... D26/3  
 D. 302,471 7/1989 Cassidy et al. .... D26/3  
 D. 304,377 10/1989 Fujita ..... D26/3  
 D. 334,244 3/1993 Shaffer et al. .... D26/3  
 D. 357,546 4/1995 Hermes ..... D26/3  
 D. 366,705 1/1996 Wang ..... D26/3  
 D. 379,673 6/1997 Sangen et al. .... D26/3

FOREIGN PATENT DOCUMENTS

96318751 1/1998 China .  
 97301218 2/1998 China .  
 97301221 2/1998 China .  
 97301222 2/1998 China .  
 97301223 2/1998 China .  
 97301224 2/1998 China .

[57] **CLAIM**

The ornamental design for a self-ballasted compact fluorescent lamps, as shown and described.

**DESCRIPTION**

FIG. 1 is a perspective view of the top, front and right side of a self-ballasted compact fluorescent lamps showing our new design;  
 FIG. 2 is a front view thereof;  
 FIG. 3 is a right side thereof;  
 FIG. 4 is a top plan view thereof;  
 FIG. 5 is a bottom view thereof;  
 FIG. 6 is a rear view thereof; and,  
 FIG. 7 is a left side view thereof.

**1 Claim, 2 Drawing Sheets**

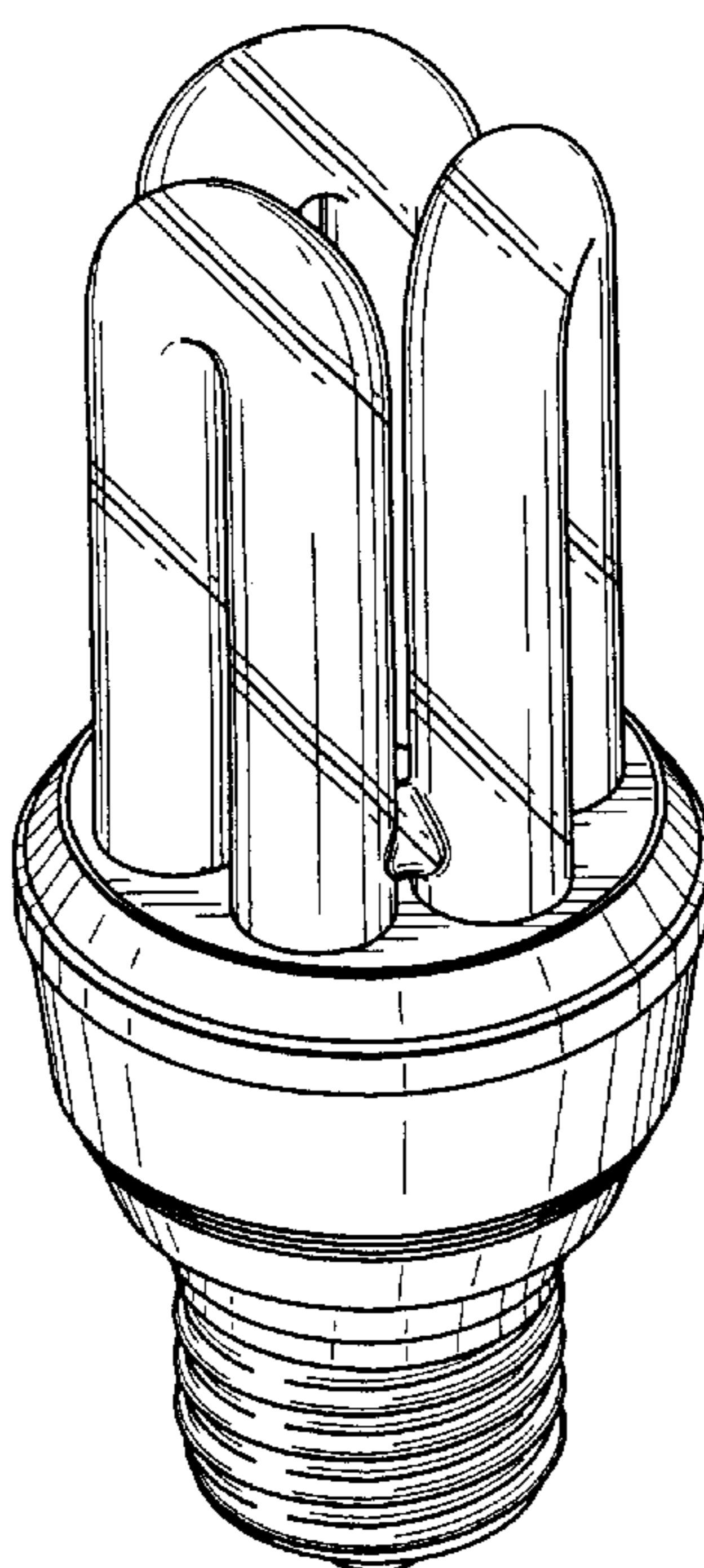

FIG. 3

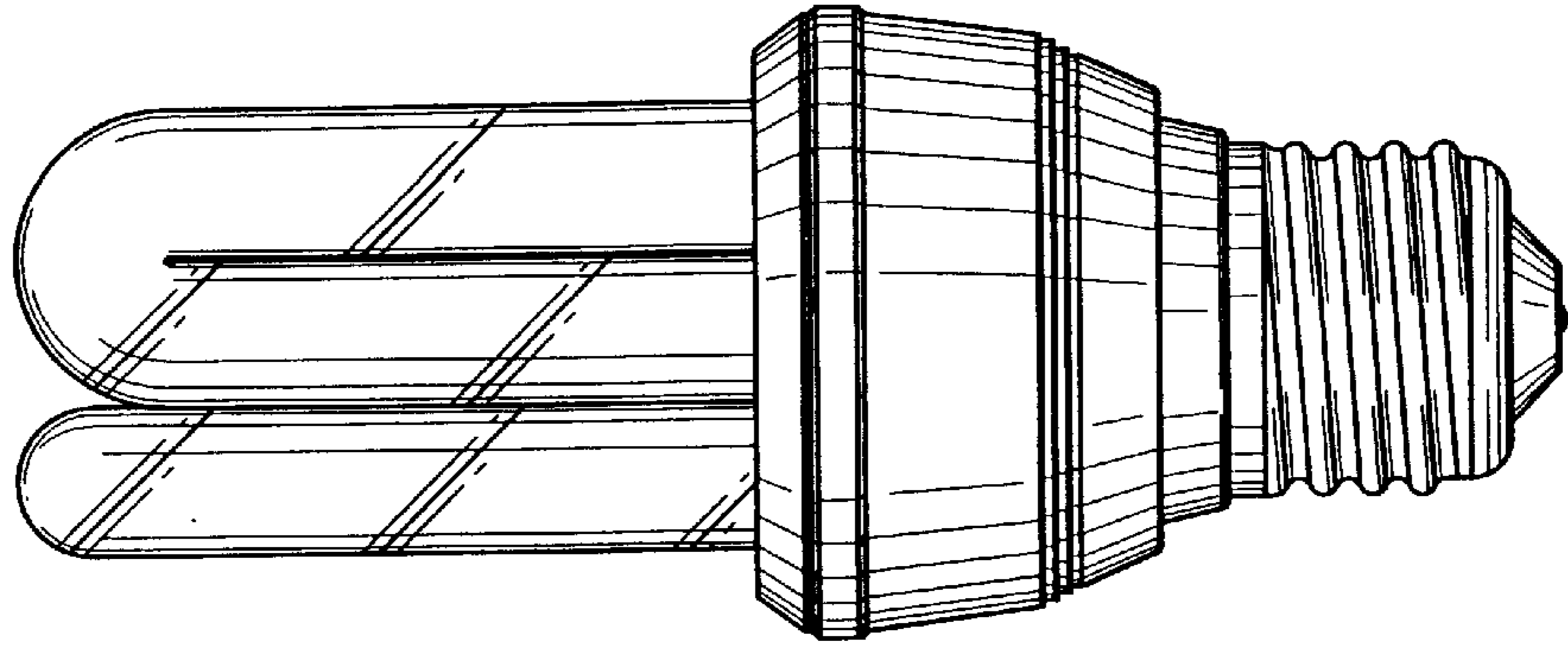

FIG. 2

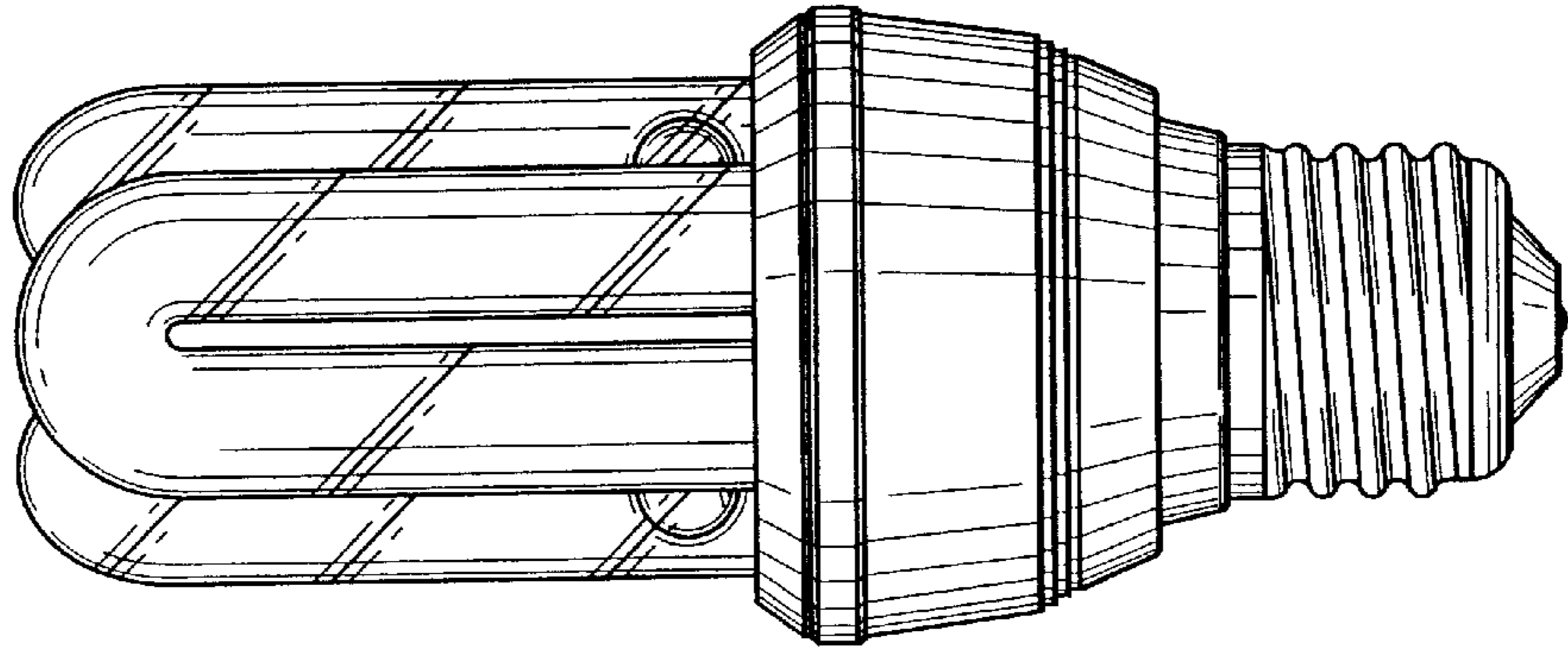
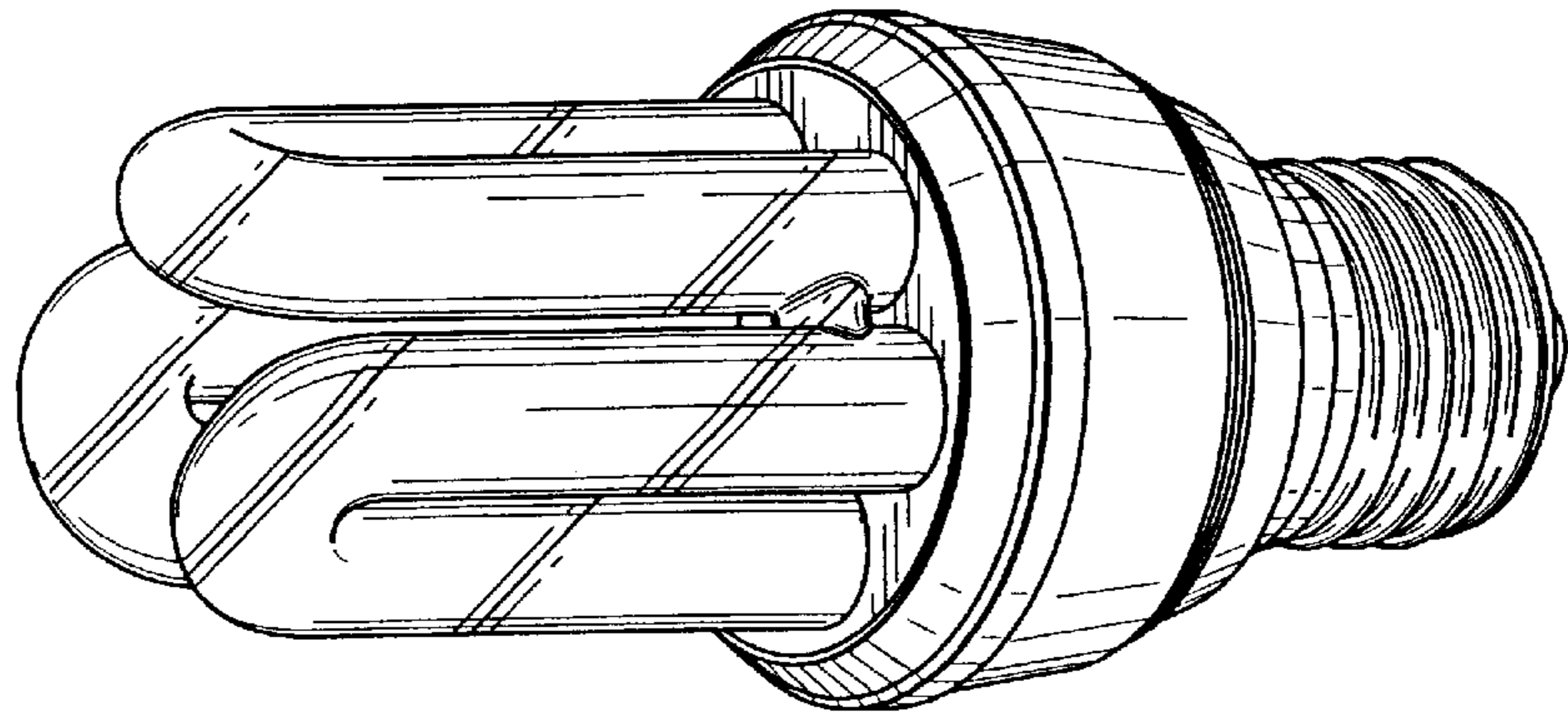
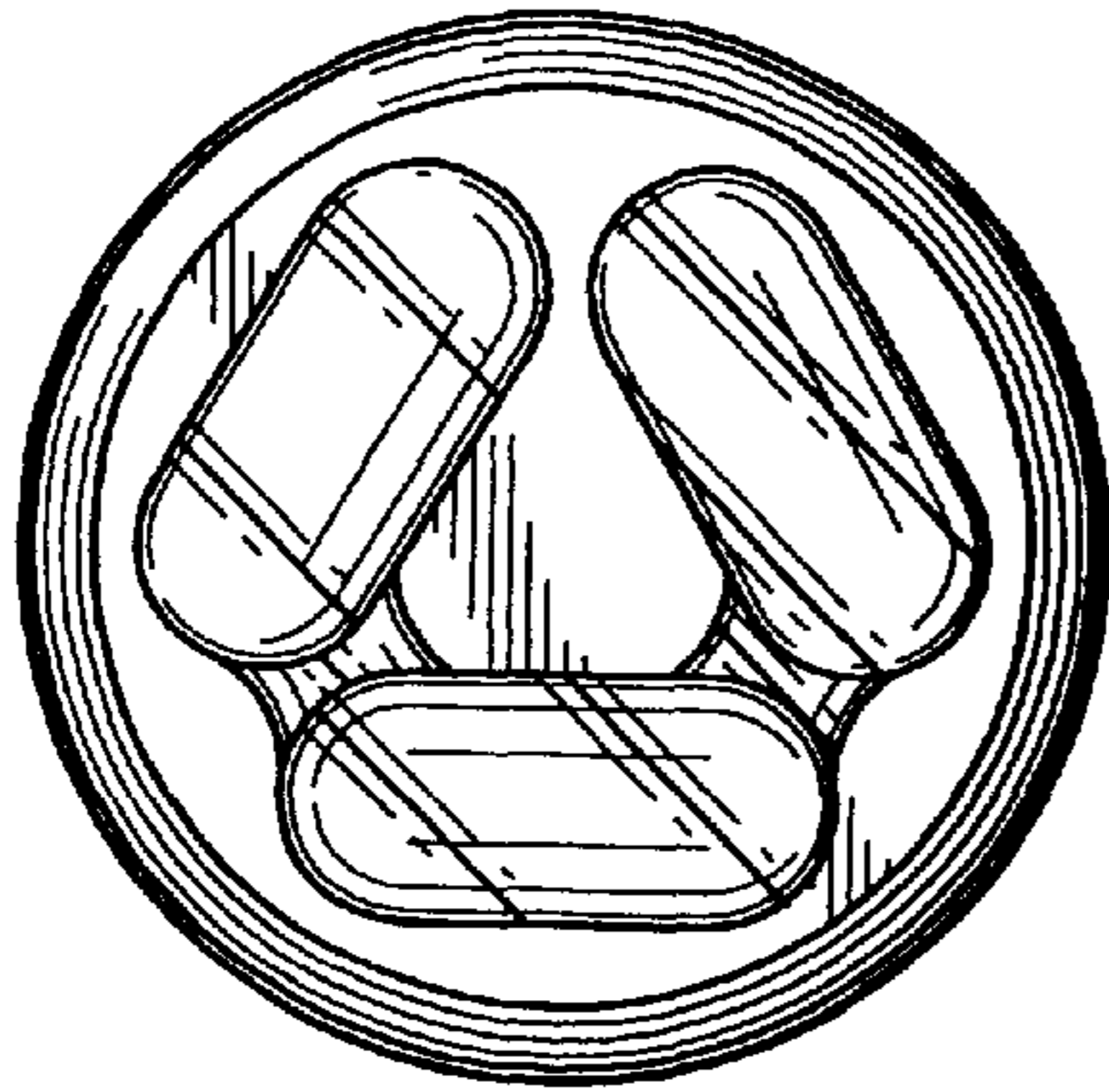

FIG. 1



*FIG. 4*



*FIG. 5*

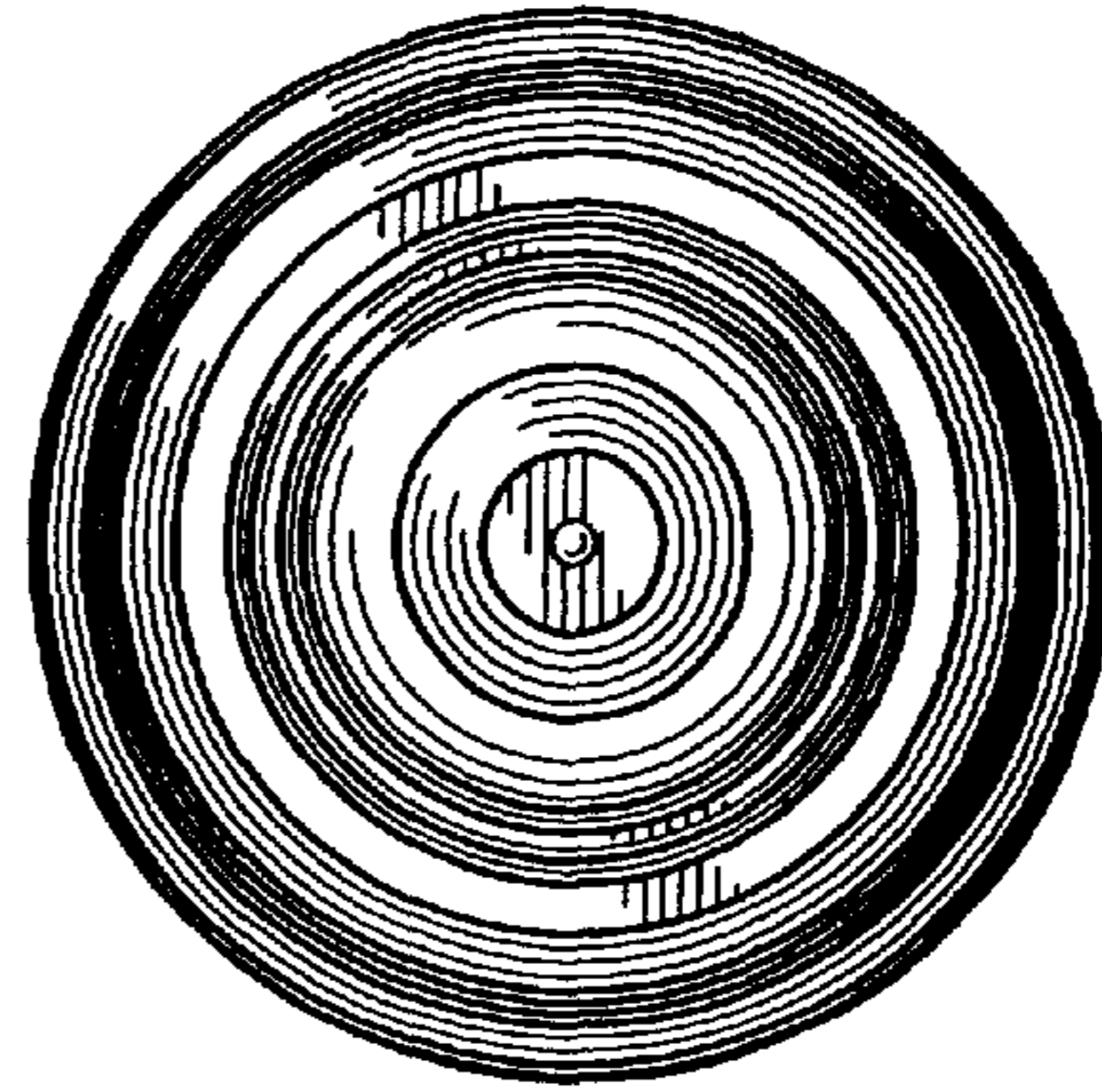

*FIG. 6*

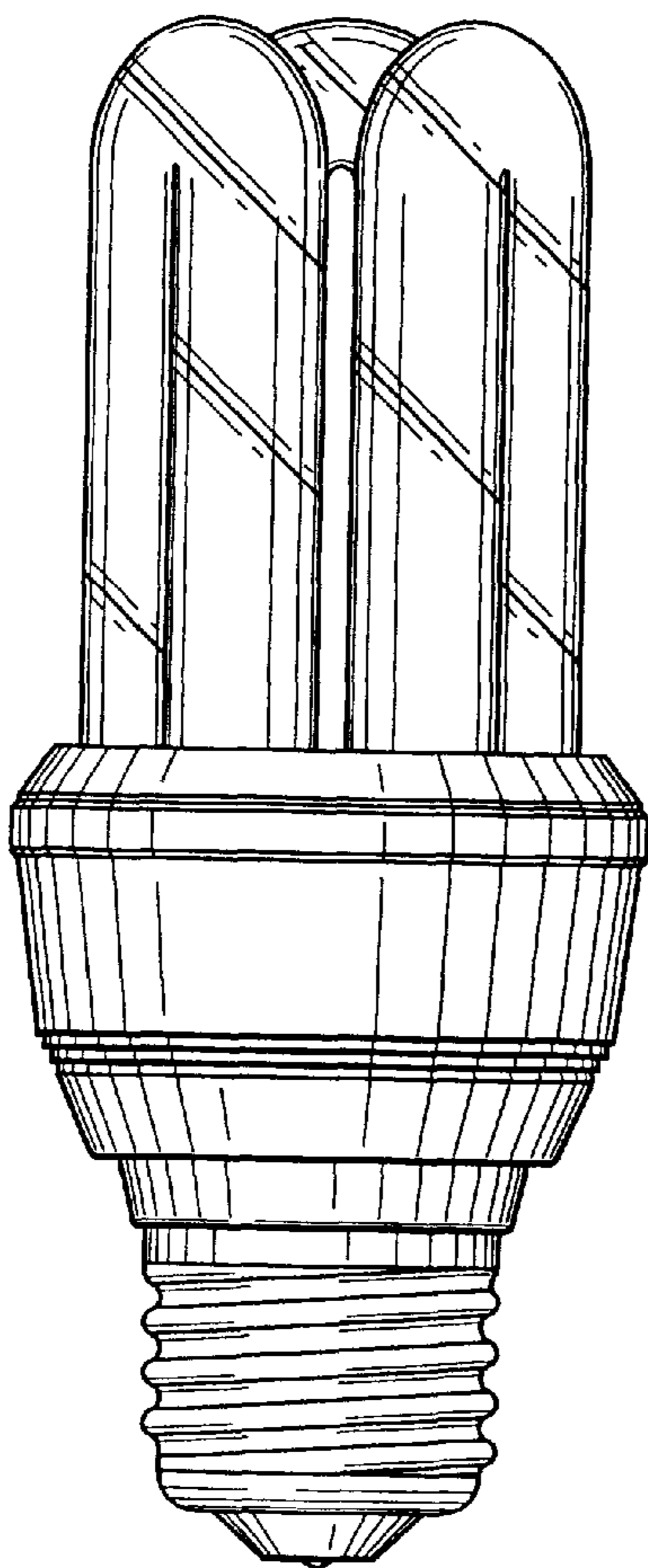

*FIG. 7*

