



US00D414816S

**United States Patent** [19]  
**Saunders**

[11] **Patent Number: Des. 414,816**

[45] **Date of Patent: \*\* Oct. 5, 1999**

[54] **CYCLE ADVERTISING DISPLAY**

[76] Inventor: **Gary C Saunders**, 186-23 Brinkerhoff Ave., St. Albans, N.Y. 11412

[\*\*] Term: **14 Years**

[21] Appl. No.: **29/067,464**

[22] Filed: **Mar. 4, 1997**

[51] **LOC (6) Cl.** ..... **20-03**

[52] **U.S. Cl.** ..... **D20/41**

[58] **Field of Search** ..... 40/590, 584, 606;  
D20/42, 43, 10, 41; 359/550

[56] **References Cited**

**U.S. PATENT DOCUMENTS**

1,852,315	4/1932	Lamb	.....	40/606
3,586,348	6/1971	Rich, Jr.	.....	359/550 X
3,945,336	3/1976	Harris	.....	40/590 X
4,862,823	9/1989	Hughes	.....	40/608 X

*Primary Examiner*—Susan J. Lucas  
*Assistant Examiner*—Jennifer Rivard  
*Attorney, Agent, or Firm*—Schweitzer Cornman Gross & Bondell LLP

[57] **CLAIM**

The ornamental design for a cycle advertising display, as shown and described.

**DESCRIPTION**

FIG. 1 is a front elevational view of the cycle advertising display showing my new design; FIG. 2 is a side elevational view thereof, the opposite side being a mirror image thereof; FIG. 3 is a top plan view thereof; and, FIG. 4 is the side elevational view thereof. The broken line disclosure of the bicycle is shown for illustrative purposes only and forms no part of the claimed design.

**1 Claim, 2 Drawing Sheets**

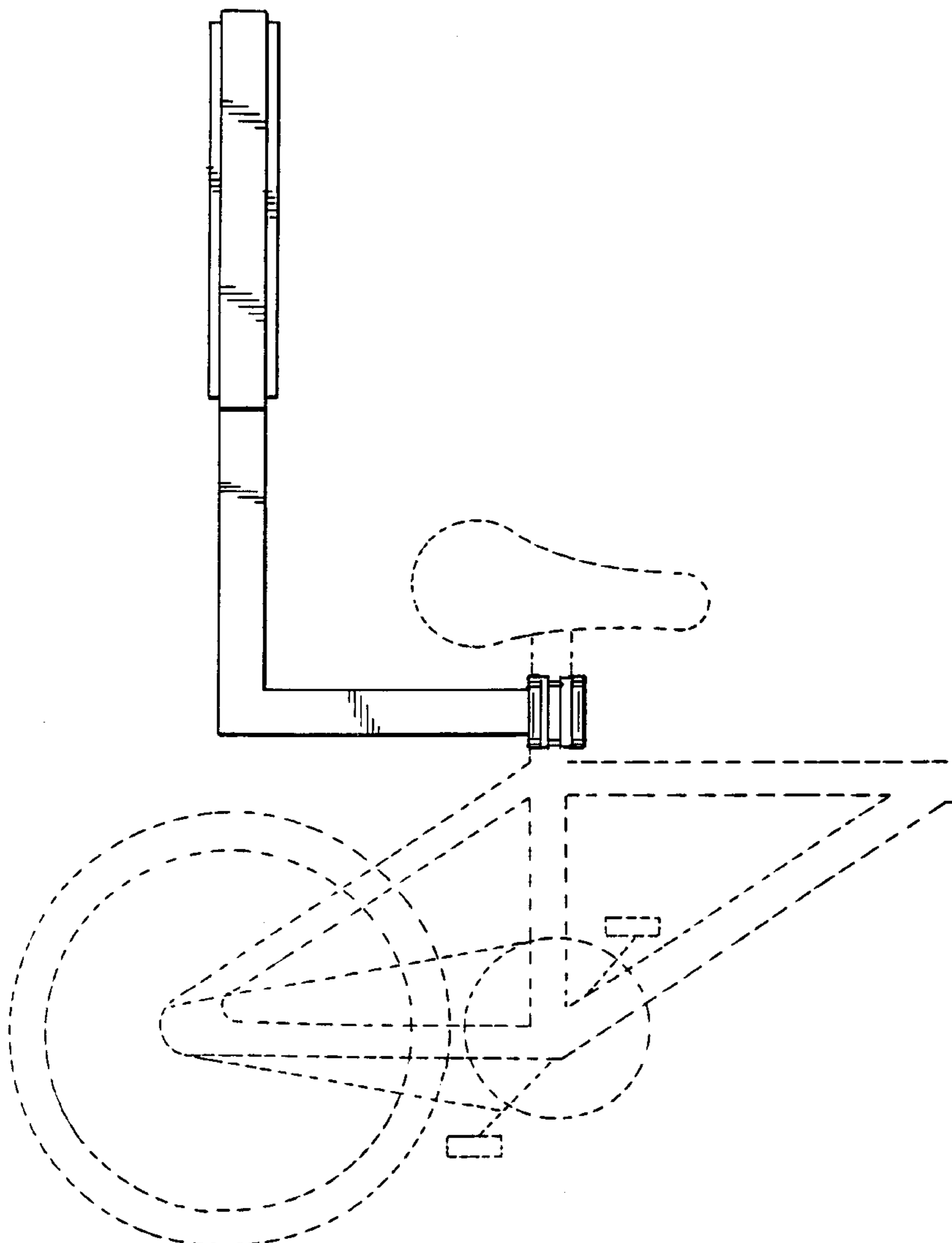

FIG. 2



FIG. 1

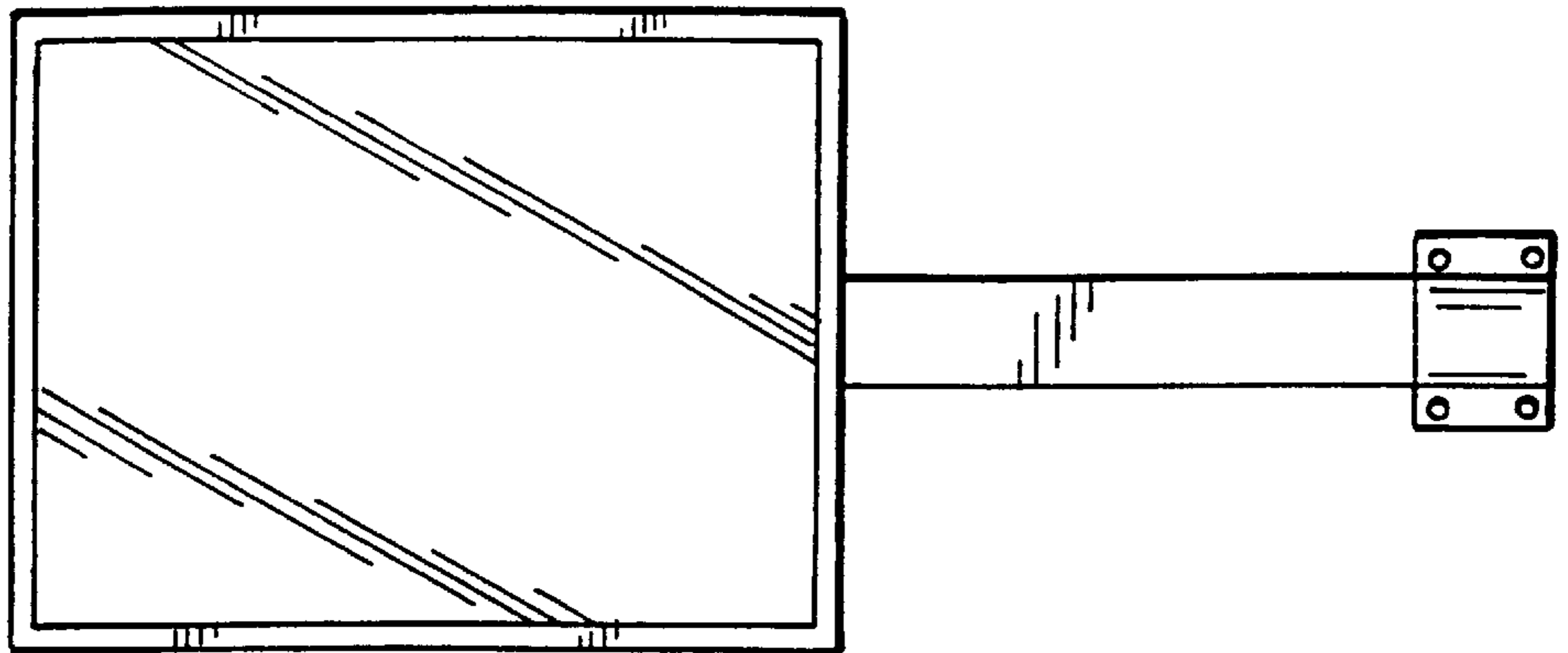

FIG. 4

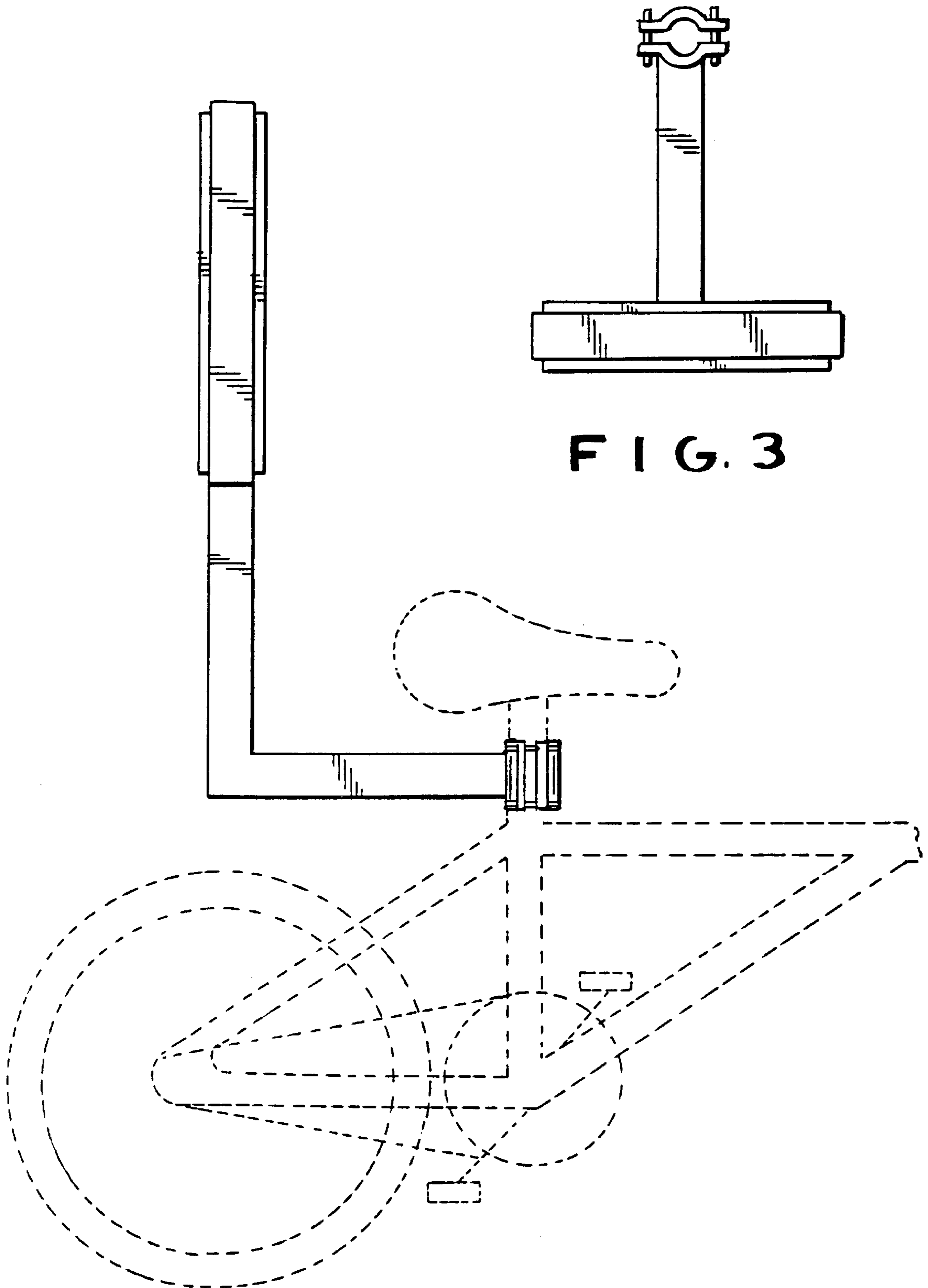

FIG. 3