



US00D414810S

# United States Patent [19]

[11] **Patent Number: Des. 414,810**

**Kwok**

[45] **Date of Patent: \*\* Oct. 5, 1999**

[54] **STATIONERY CAR**

[75] Inventor: **Tat Cheong Kwok**, Chaiwan, The Hong Kong Special Administrative Region of the People's Republic of China

[73] Assignee: **Kwok's Brother Manufacturing Limited**, Chaiwan, The Hong Kong Special Administrative Region of the People's Republic of China

[\*\*] Term: **14 Years**

[21] Appl. No.: **29/097,849**

[22] Filed: **Dec. 15, 1998**

[51] **LOC (6) Cl.** ..... **19-06**

[52] **U.S. Cl.** ..... **D19/82; D19/83; D19/97; D19/75; D3/271; D21/548**

[58] **Field of Search** ..... D21/424, 533, D21/548-550; D19/35, 36, 65, 69, 75, 77, 78, 81-85, 86, 95, 100, 97, 96; 206/214, 224, 371, 457, 358; D3/206, 270, 271

[56] **References Cited**

**U.S. PATENT DOCUMENTS**

D. 79,822 11/1929 Larrabee ..... D19/82 X

D. 197,934	4/1964	Weaver	.....	D19/69
D. 309,474	7/1990	Murai	.....	D19/75
D. 316,273	4/1991	Tsuji	.....	D19/82 X
D. 354,311	1/1995	Tarozzi	.....	D19/82
D. 364,893	12/1995	Willard et al.	.....	D19/82
4,753,346	6/1988	Tsuji	.....	206/371
5,441,149	8/1995	Willard et al.	.....	206/214

*Primary Examiner*—Martie K. Holtje  
*Attorney, Agent, or Firm*—Sheridan Ross, P.C.

[57] **CLAIM**

The ornamental design for a stationery car, as shown and described.

**DESCRIPTION**

FIG. 1 is a front view in elevation of the stationery car of the present invention;  
FIG. 2 is a rear view in elevation of the stationery car of the present invention;  
FIG. 3 is a right side view in elevation of the stationery car of the present invention;  
FIG. 4 is left side view in elevation of the stationery car of the present invention;  
FIG. 5 is a bottom plan view of the stationery car of the present invention; and,  
FIG. 6 is a top plan view of the stationery car of the present invention.

**1 Claim, 3 Drawing Sheets**

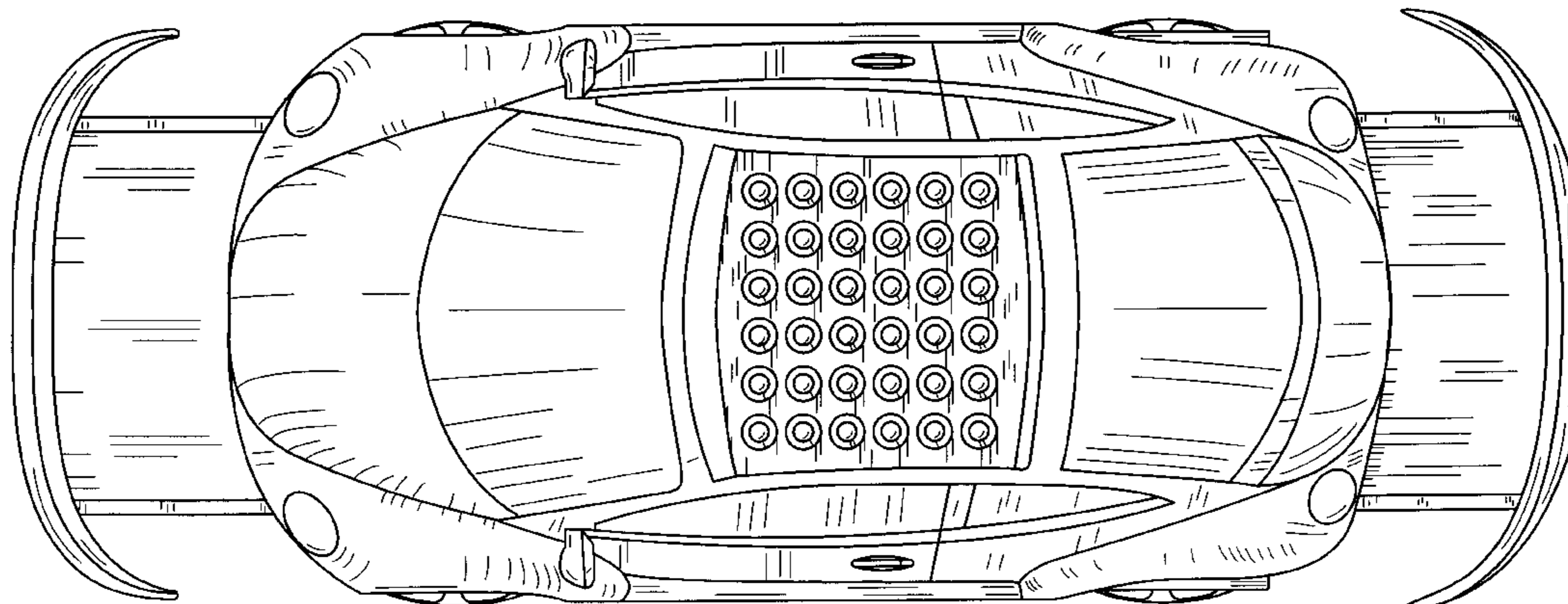
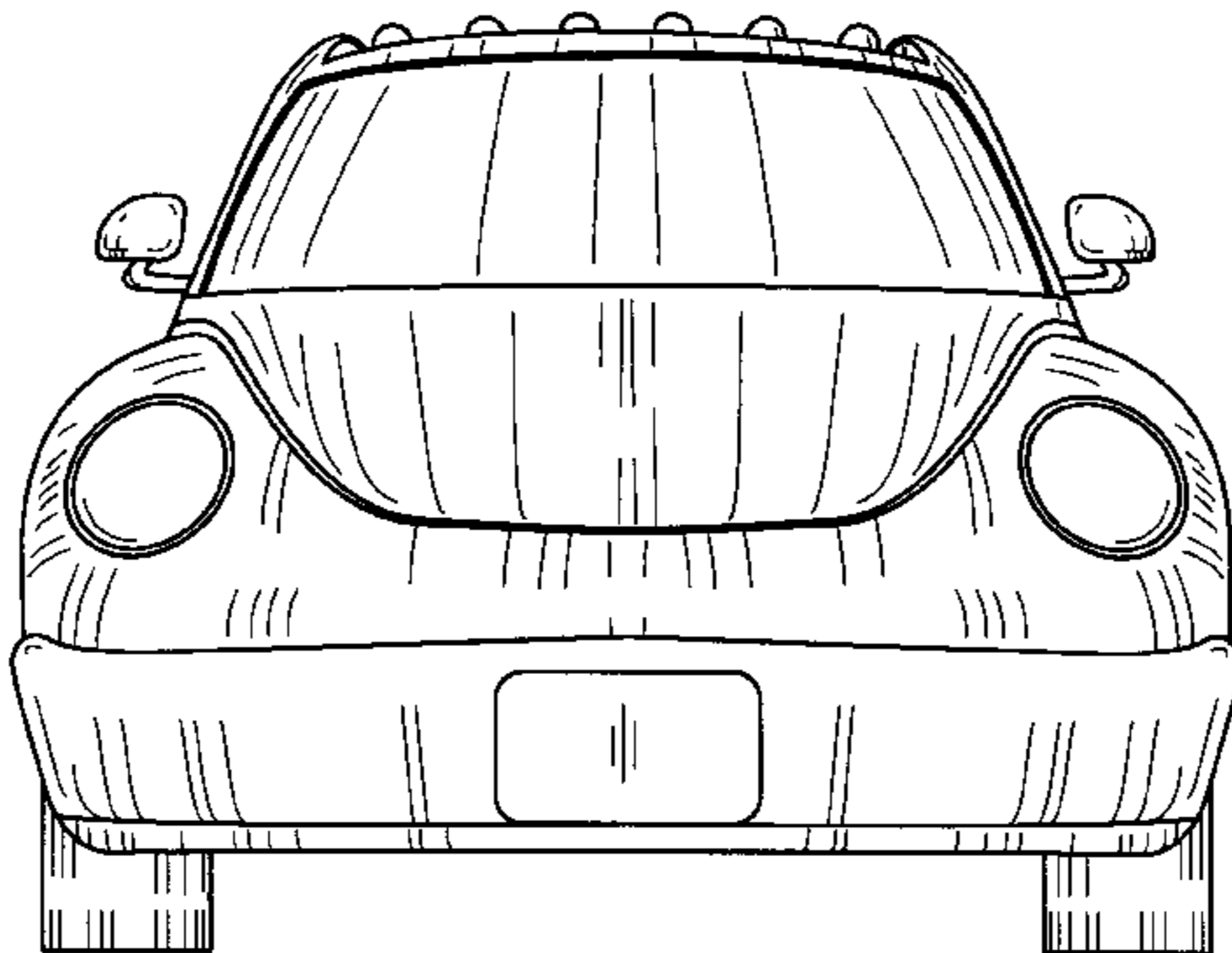

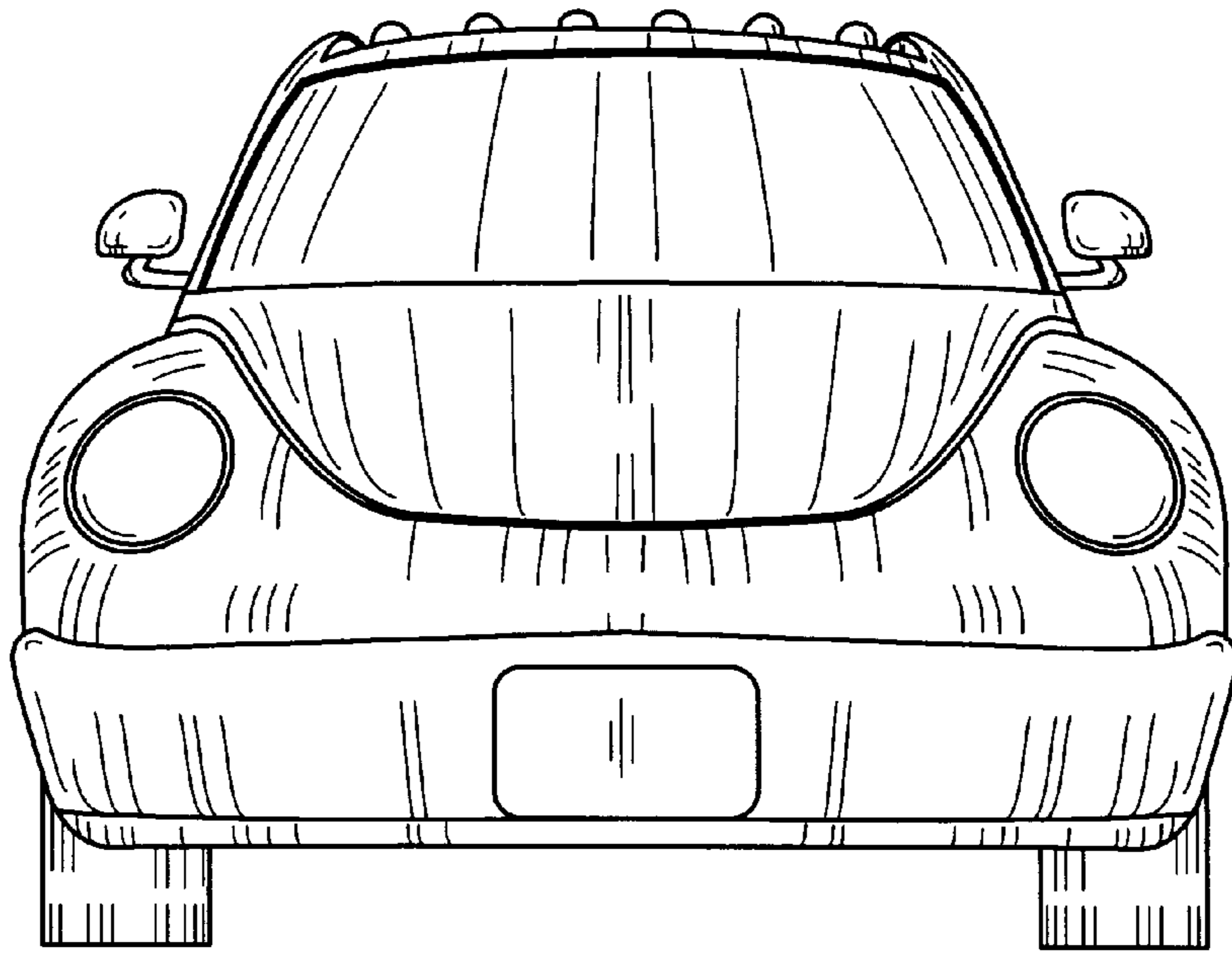

Fig. 1

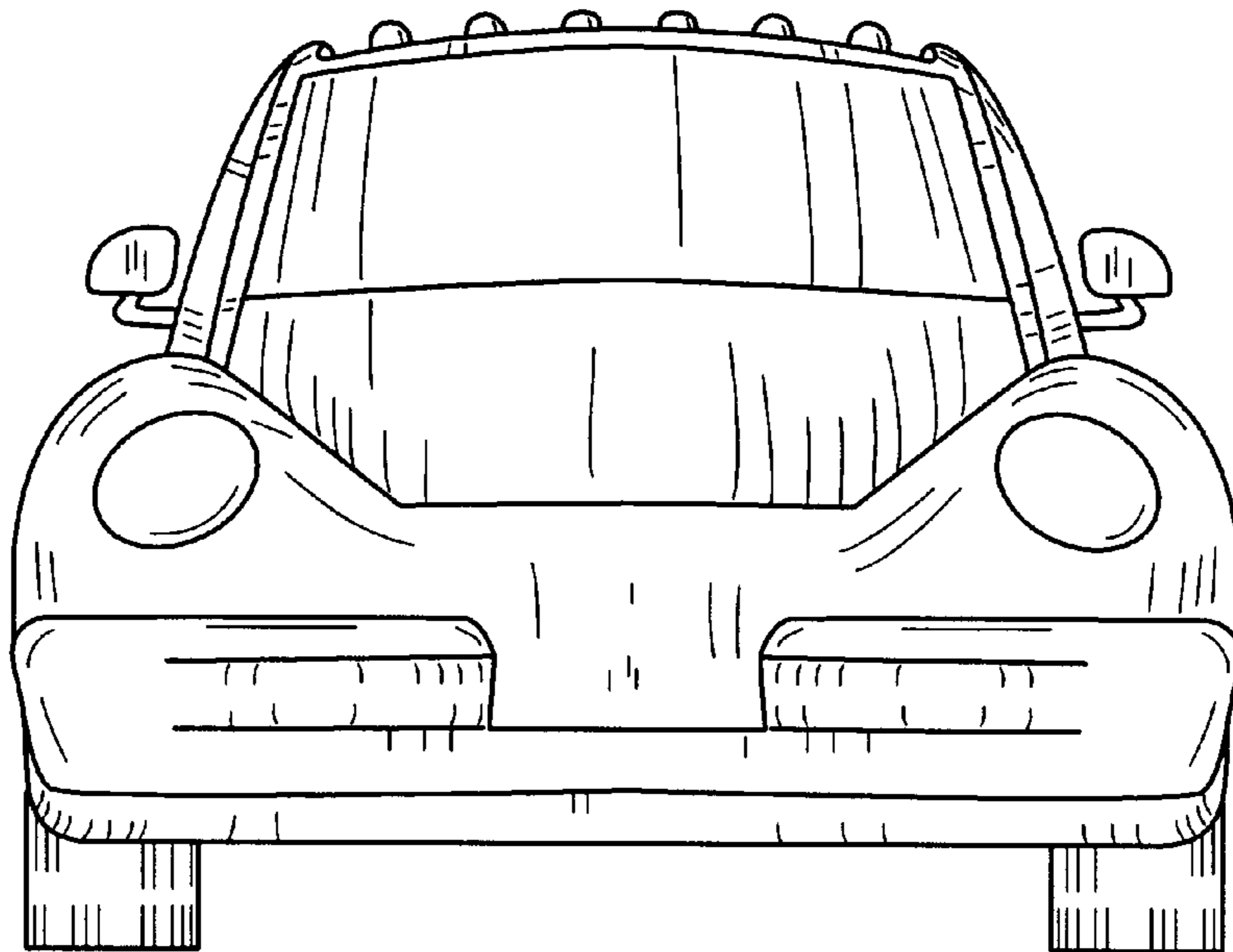

Fig. 2

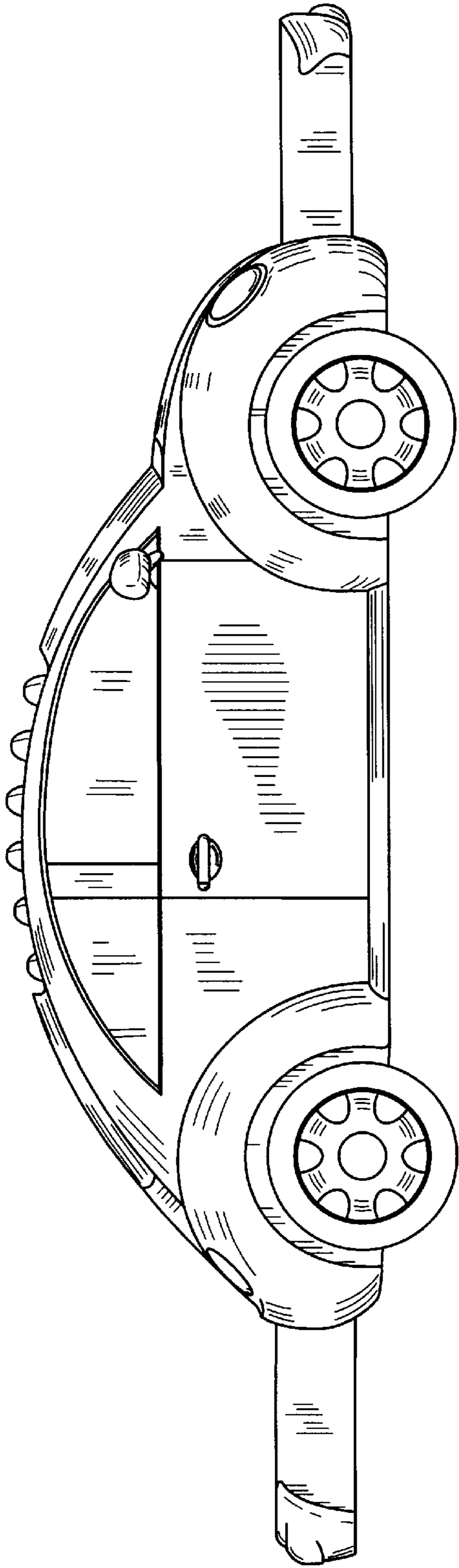

Fig. 3

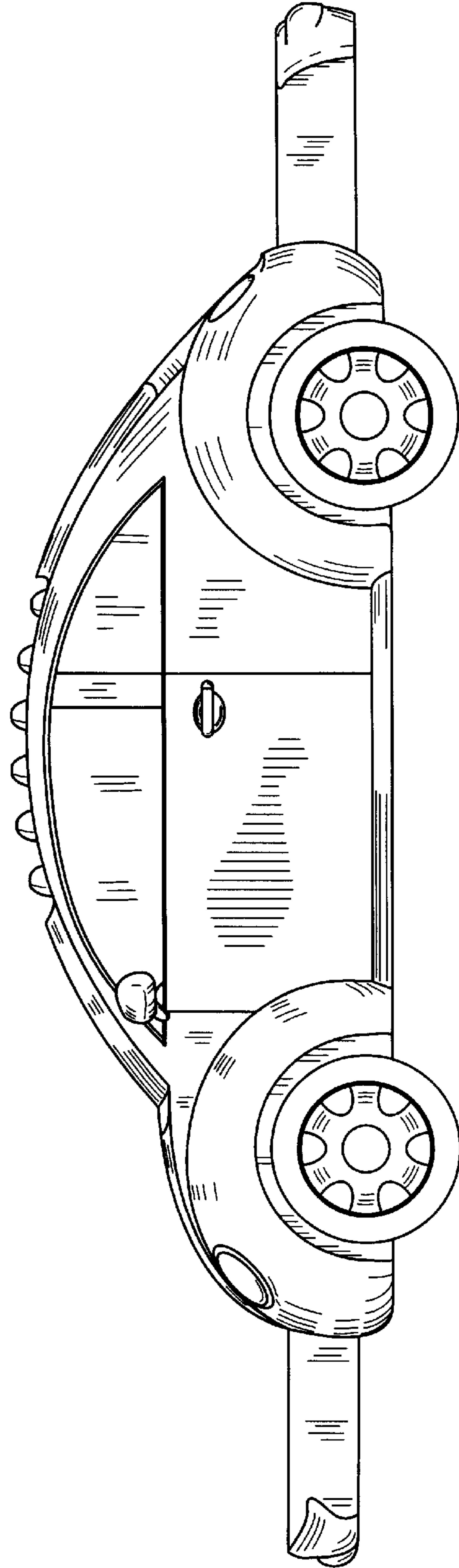

Fig. 4

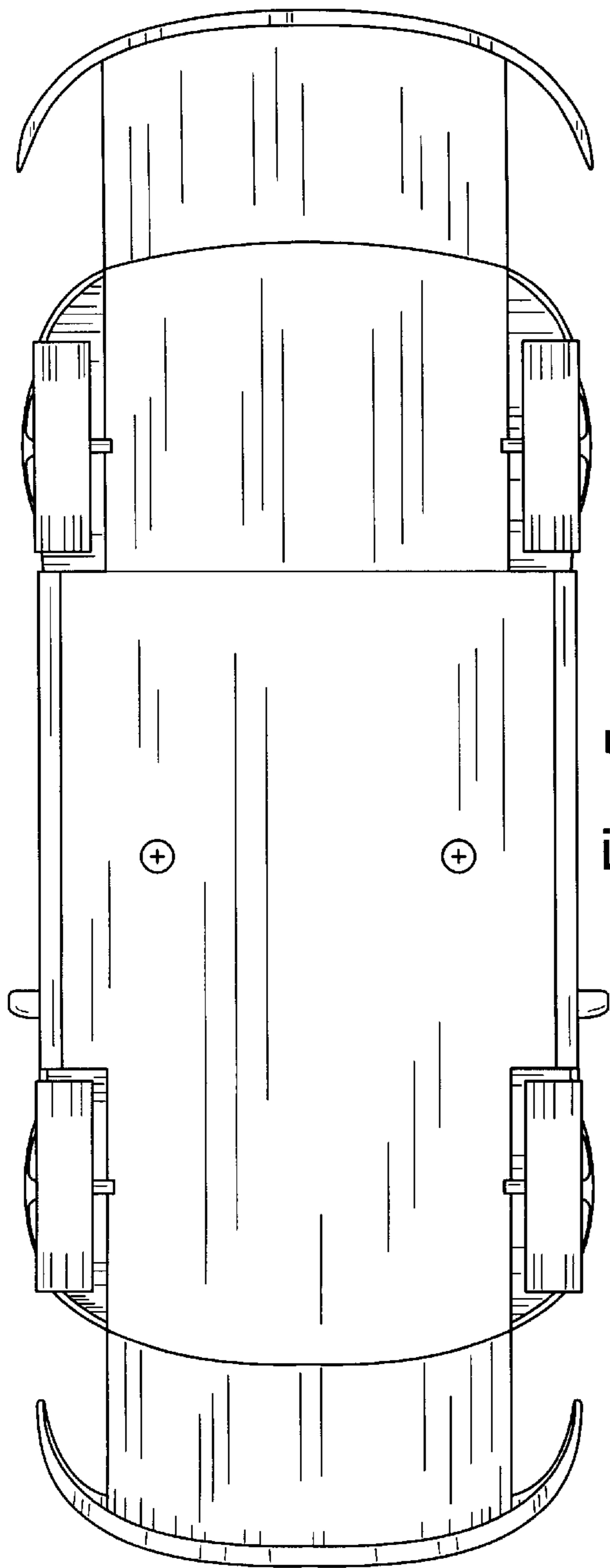

Fig. 5

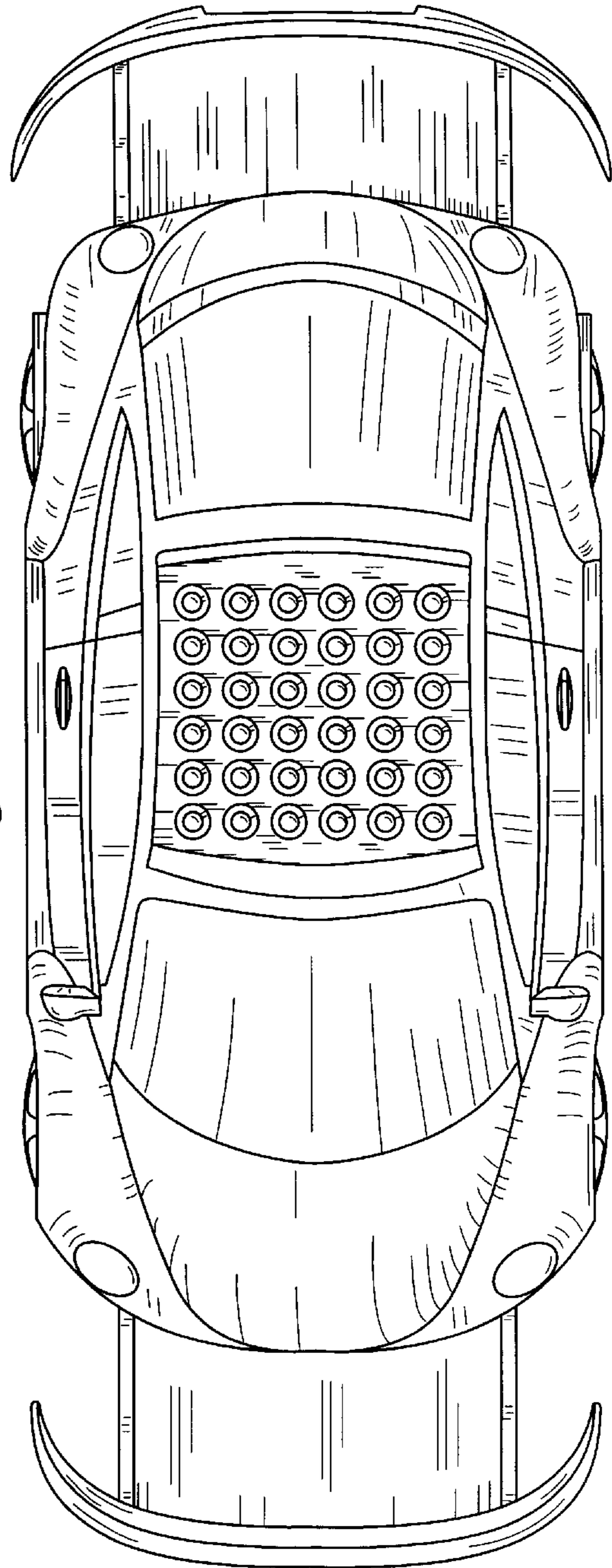

Fig. 6