



US00D414790S

United States Patent [19]
Lannoch

[11] **Patent Number: Des. 414,790**

[45] **Date of Patent: ** Oct. 5, 1999**

[54] **RXF-GEAR**

[75] Inventor: **Hans-Jürgen Lannoch,**
Linkenheim-Hochstetten, Germany

[73] Assignee: **Sew-Eurodrive GmbH & Co.,**
Bruchsal, Germany

[**] Term: **14 Years**

[21] Appl. No.: **29/085,856**

[22] Filed: **Mar. 31, 1998**

[51] **LOC (6) Cl.** **15-09**

[52] **U.S. Cl.** **D15/148**

[58] **Field of Search** D15/148, 149;
474/144, 82; 74/606, 606 A, 609

[56] **References Cited**

U.S. PATENT DOCUMENTS

D. 330,559 10/1992 Dornhoff D15/148

Primary Examiner—Antoine Duval Davis
Attorney, Agent, or Firm—Antonelli, Terry, Stout & Kraus,
LLP

[57] **CLAIM**

I claim the ornamental design for an RXF-gear, as shown.

DESCRIPTION

FIG. 1 is a front elevational view of the RXF-gear of the present invention;
FIG. 2 is a rear elevational view thereof;
FIG. 3 is a right side elevational view thereof;
FIG. 4 is a left side elevational view thereof;
FIG. 5 is a top plan view thereof;
FIG. 6 is a bottom plan view thereof;
FIG. 7 is a rear and right side perspective view thereof; and,
FIG. 8 is a front and right side perspective view thereof wherein the RXF-gear is rotated in a vertical plane 180°C. from the view shown in FIG. 7;

1 Claim, 4 Drawing Sheets

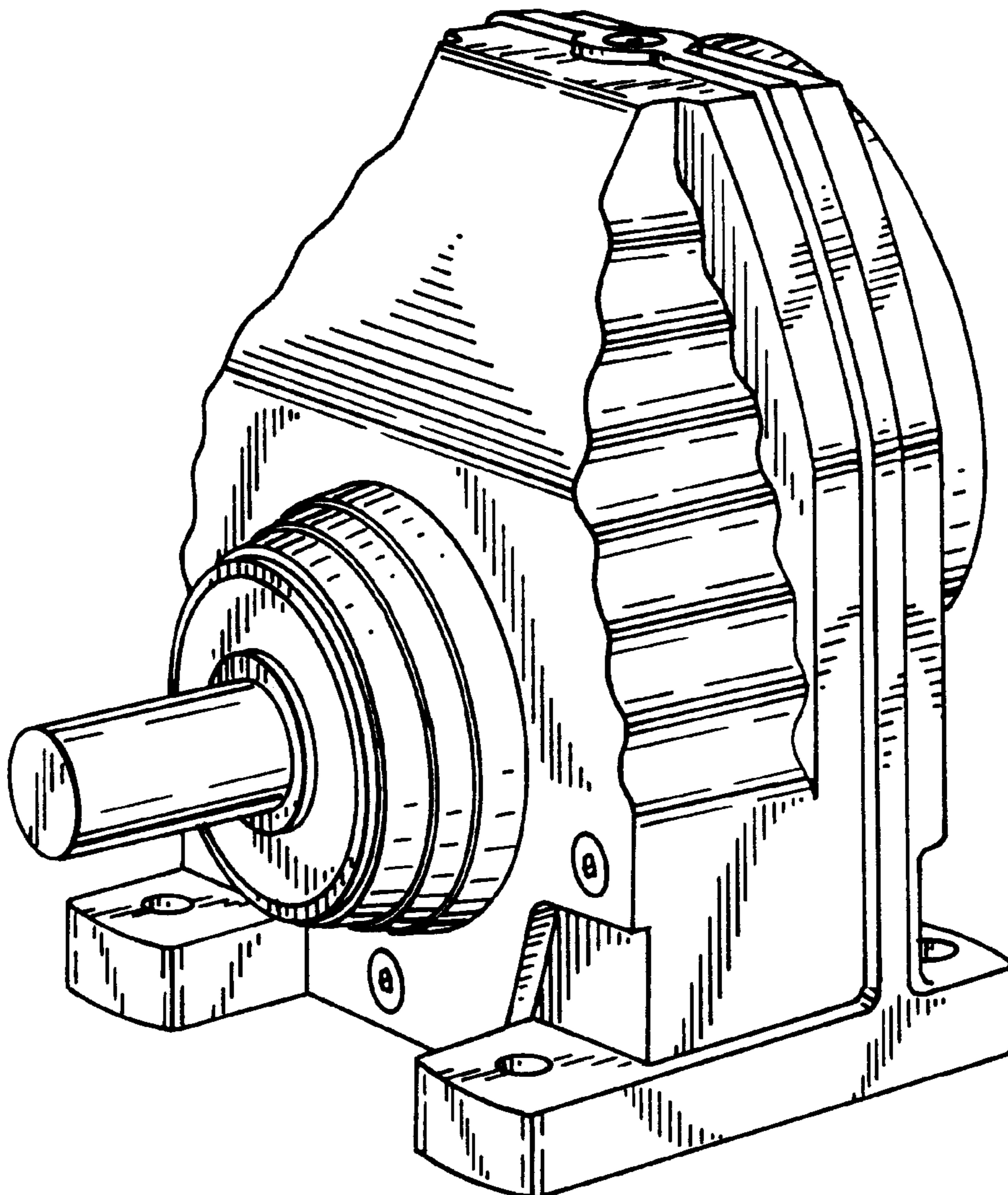

FIG. 2

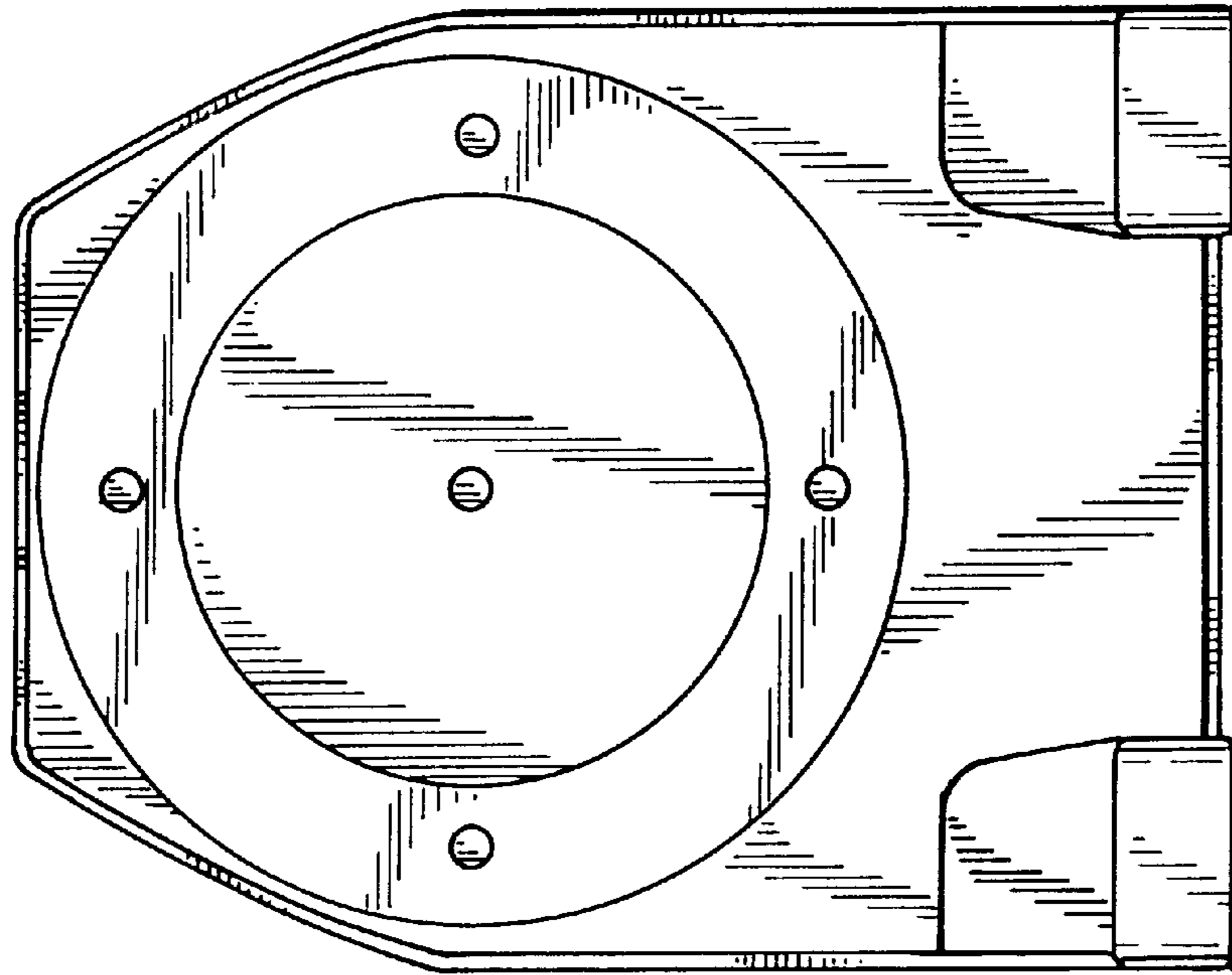

FIG. 1

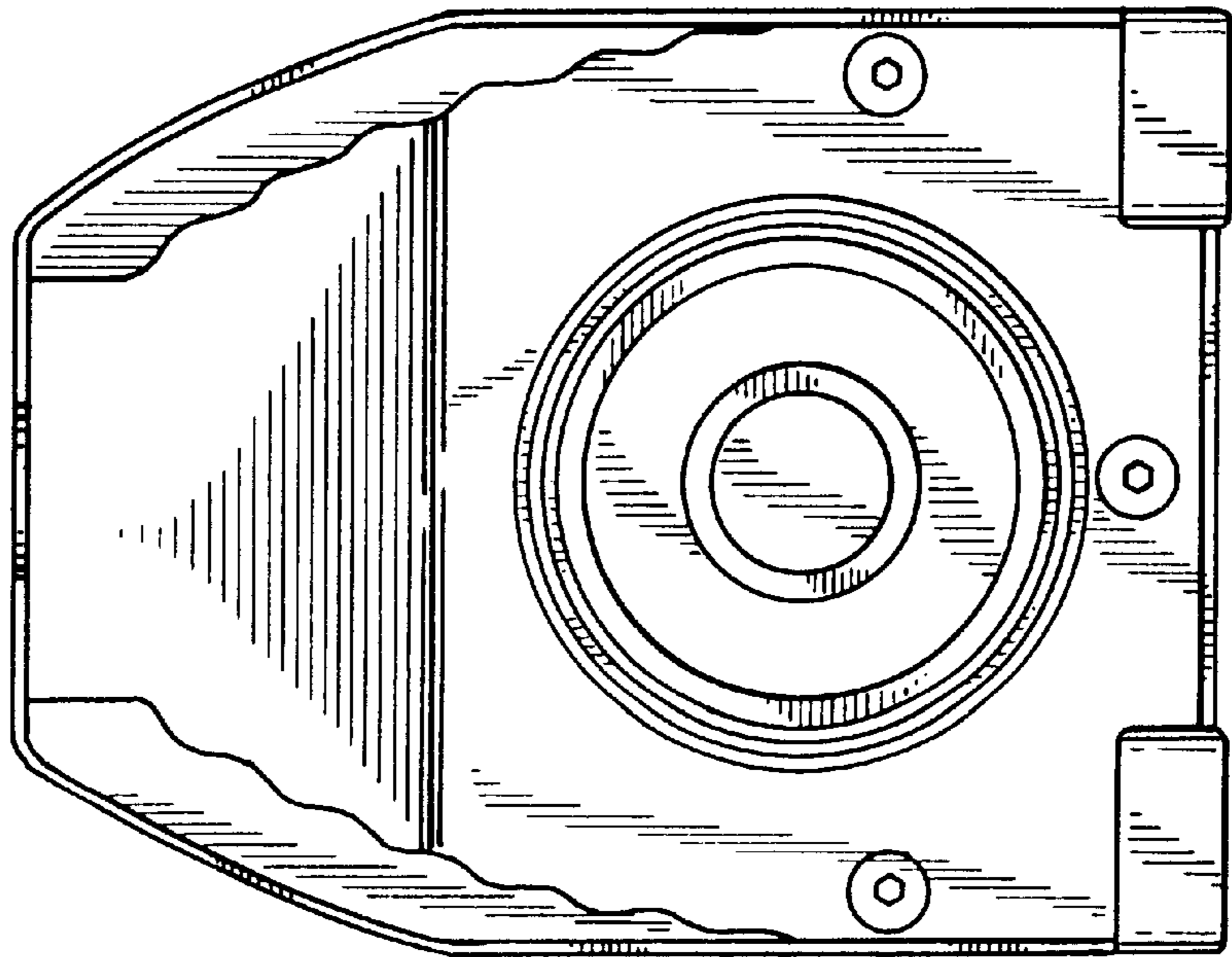

FIG. 4

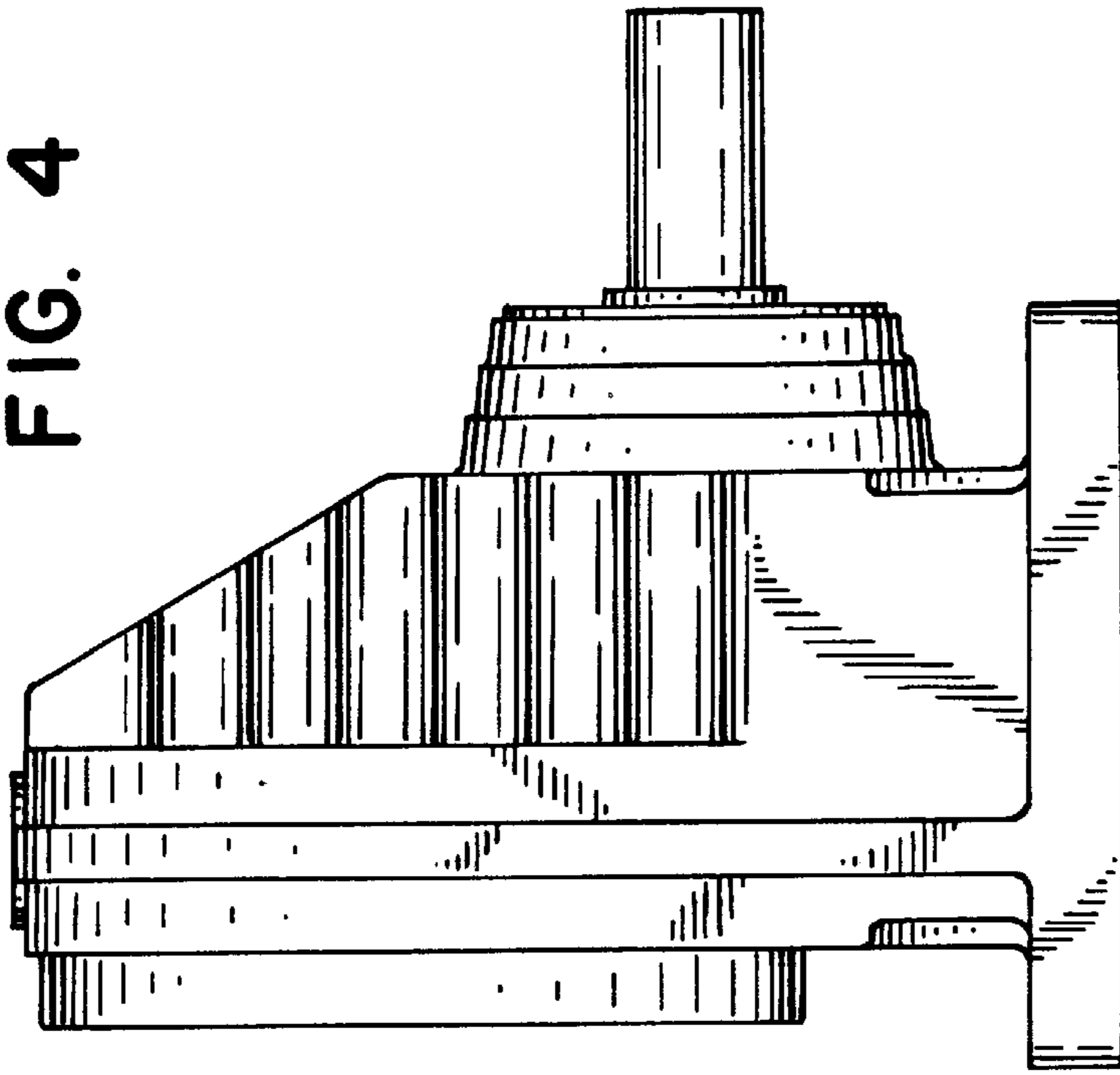

FIG. 3

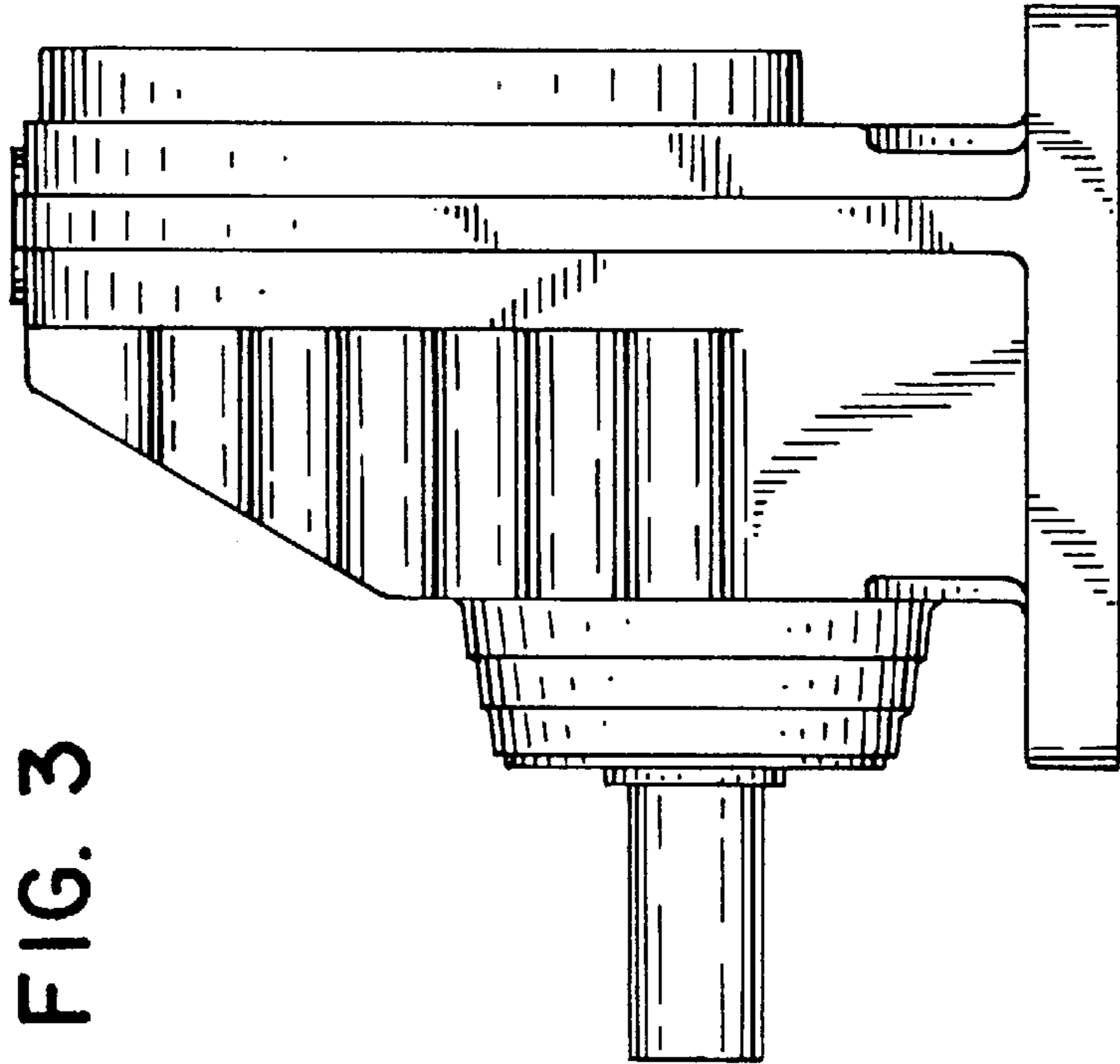

FIG. 6

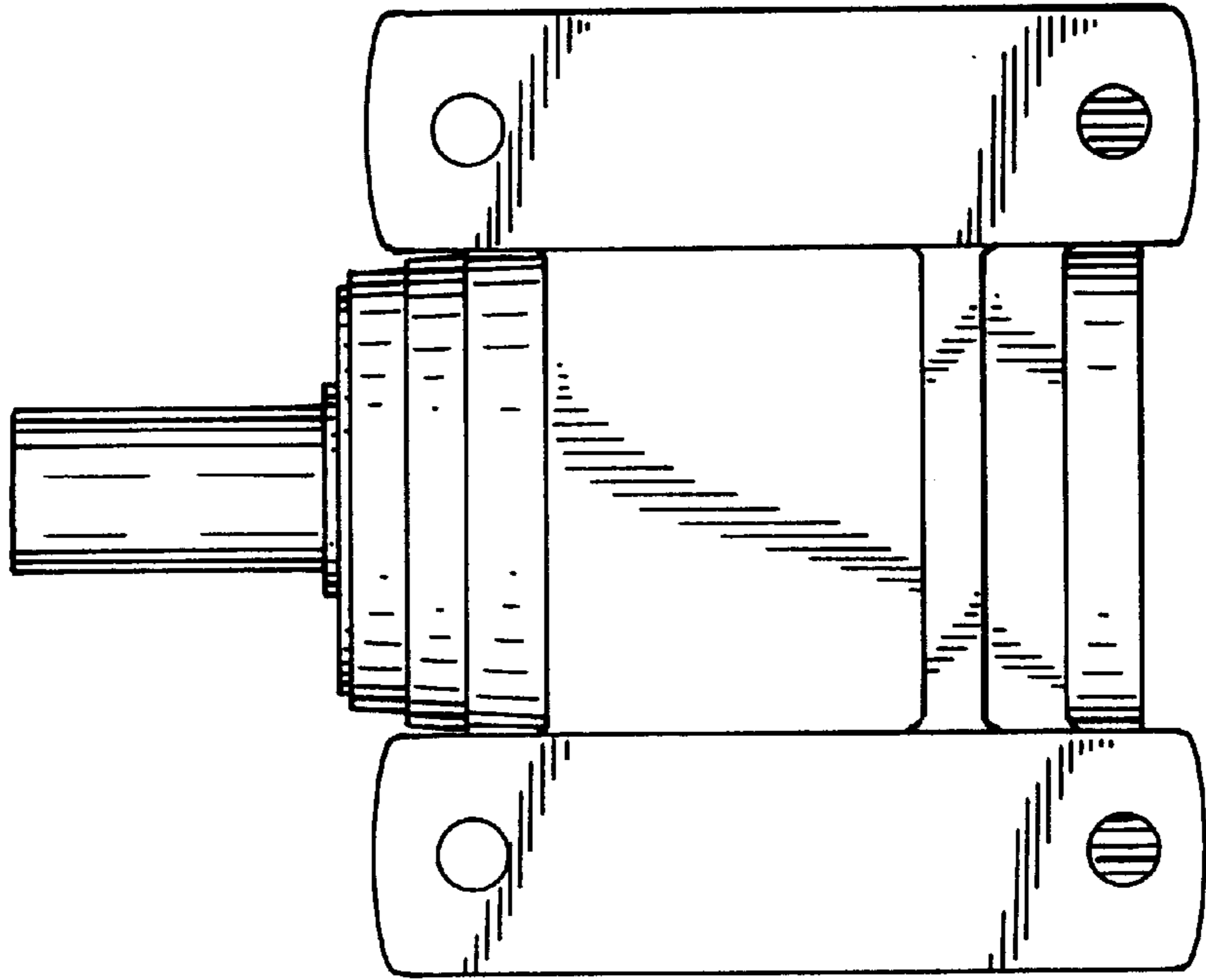

FIG. 5

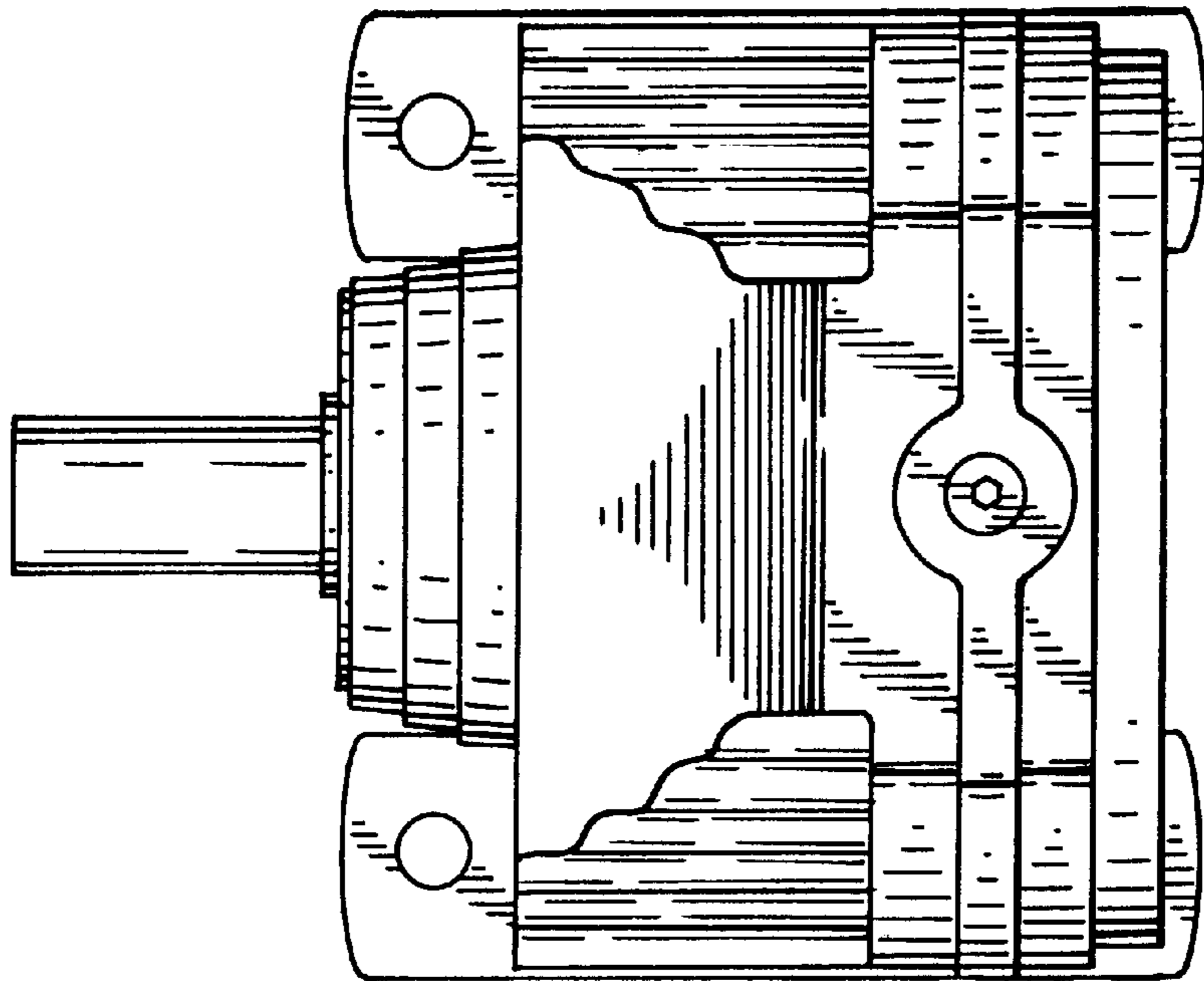

FIG. 8

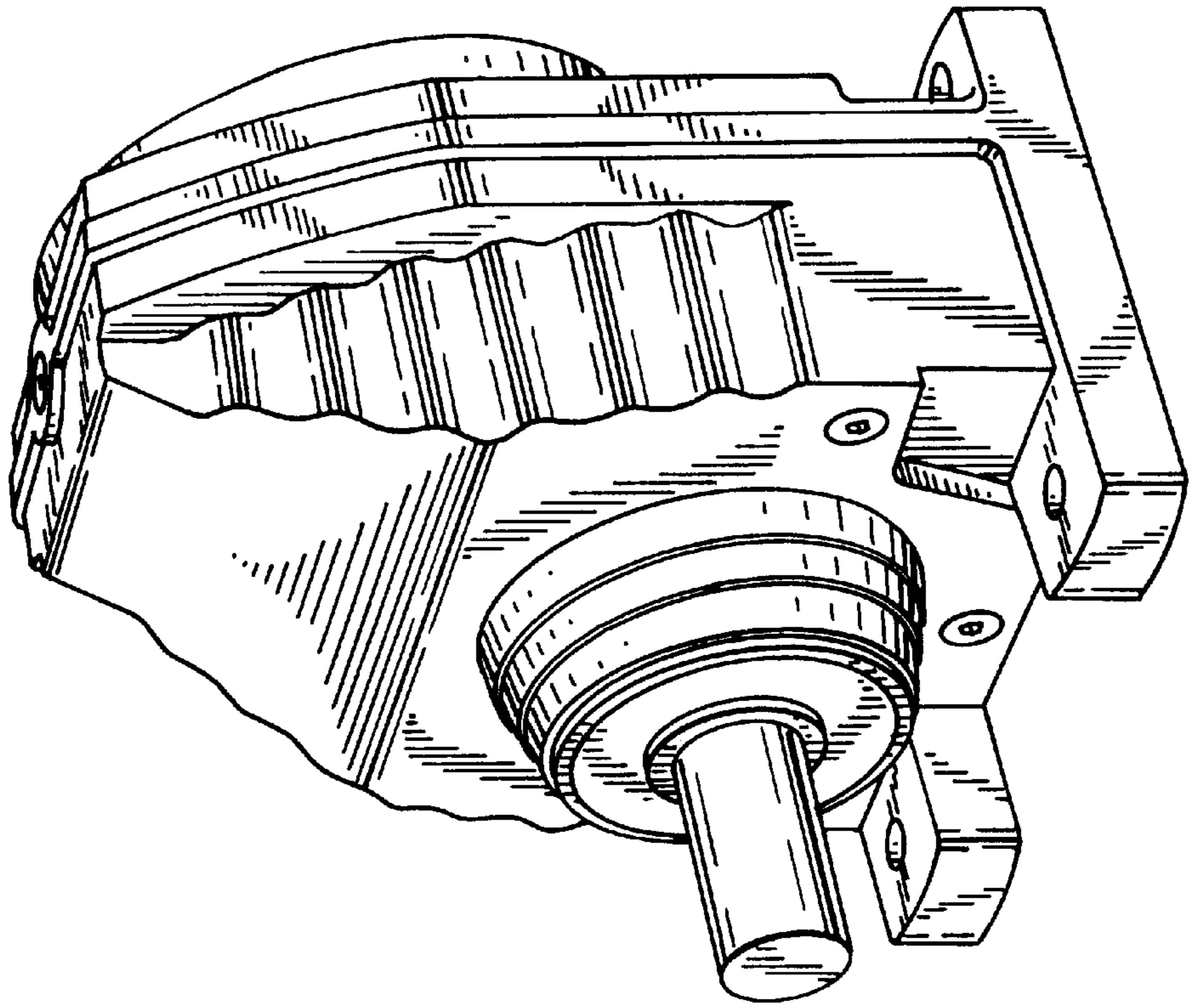

FIG. 7

