



US00D414779S

United States Patent [19]

[11] **Patent Number: Des. 414,779**

McSpadden et al.

[45] **Date of Patent: ** *Oct. 5, 1999**

[54] **FUEL DISPENSING UNIT**

OTHER PUBLICATIONS

[75] Inventors: **John S. McSpadden**, Greensboro, N.C.; **Cheryl Felix**, Bedford; **Charles C. Keane**, Hingham, both of Mass.

“BP Apollo—NZ Trial Site Review” (Aug. 14, 1998).

“Loyalty Builders”. No Date.

“V390” (1994).

“V390U” (1994).

[73] Assignee: **Gilbarco Inc.**, Greensboro, N.C.

“Customer Interface Terminal”. No Date.

[*] Notice: This patent is subject to a terminal disclaimer.

“Horizon 2000 Series Dispenser”. No Date.

“The Premier Series H422B: with Insight” (Aug. 1997).

[**] Term: **14 Years**

“Dispensers”. No Date.

“The Advantage Series Model Guide” by Gilbarco Inc. (1996).

[21] Appl. No.: **29/089,944**

“Multidispenser Advantage”. No Date.

“Universal Univision” by Universal Epsco, Inc. (1995).

[22] Filed: **Jun. 26, 1998**

“Centurion—A Sophisticated and Reliable Dispenser” by Schlumberger Electronics Transaction (1997).

[51] **LOC (6) Cl. 15-02**

[52] **U.S. Cl. D15/9.2**

[58] **Field of Search** D15/9.1, 9.2; 137/234.6; 222/26, 28, 23, 71, 74, 372; 141/198; 251/129.04

Primary Examiner—Ralf Seifert

Attorney, Agent, or Firm—Jenkins & Wilson, P.A.

[56] **References Cited**

[57] **CLAIM**

The ornamental design for a fuel dispensing unit, as shown and described.

U.S. PATENT DOCUMENTS

DESCRIPTION

D. 196,263	9/1963	Romanowski	D15/9.2
D. 244,563	5/1977	Taylor et al.	D52/2
D. 262,970	2/1982	Rowan et al.	D15/9.2
D. 262,971	2/1982	Robinson, Jr. et al.	D15/9.2
D. 264,471	5/1982	Rowan et al.	D15/9.2
D. 265,092	6/1982	Robinson, Jr. et al.	D15/9.2
D. 306,719	3/1990	Austin et al.	D14/105
D. 309,144	7/1990	Austin et al.	D15/9.2
D. 316,471	4/1991	Austin et al.	D99/43
D. 334,199	3/1993	Ballew	D15/9.2
5,630,528	5/1997	Nanaji	222/71
5,651,478	7/1997	Tatsuno	222/71

FIG. 1 is a right front perspective view of a fuel dispenser showing our new design;

FIG. 2 is a front elevational view thereof;

FIG. 3 is a right side elevational view wherein the left side is similar in appearance to the right side;

FIG. 4 is a left rear perspective view thereof; and,

FIG. 5 is a top plan view thereof.

1 Claim, 3 Drawing Sheets

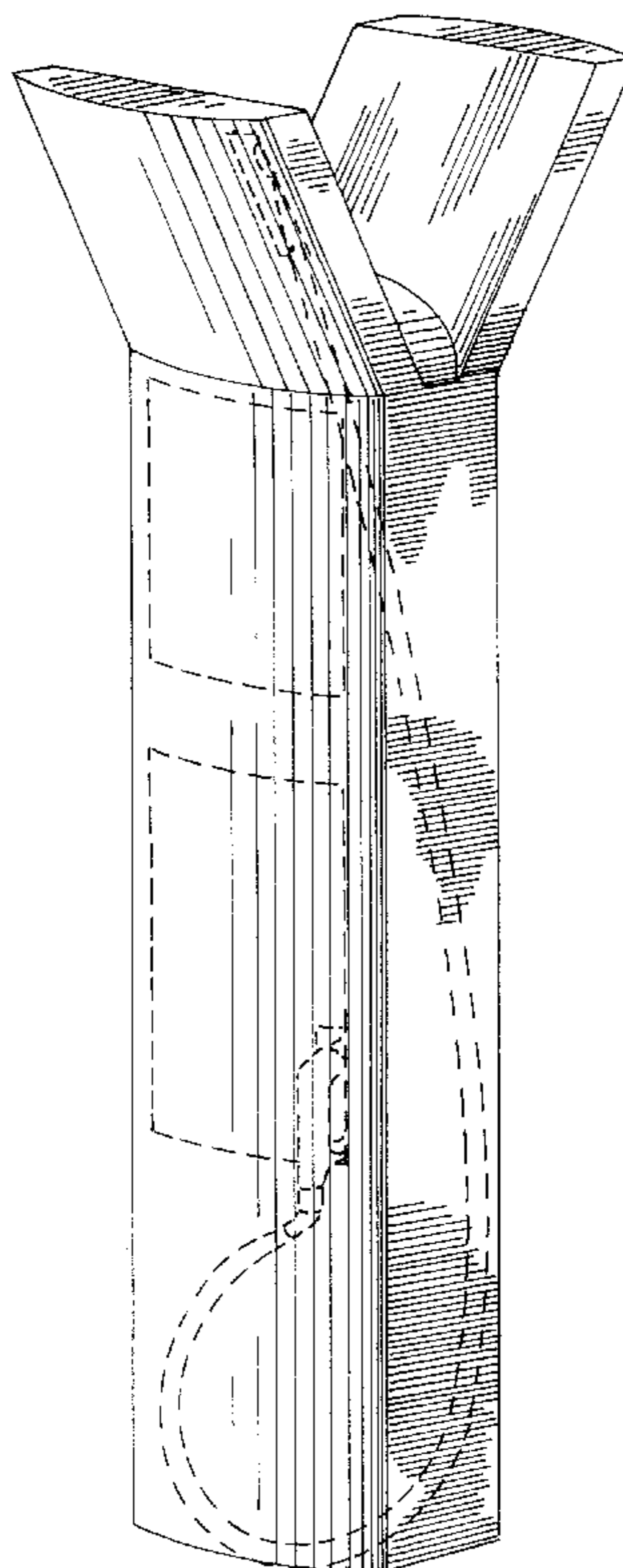

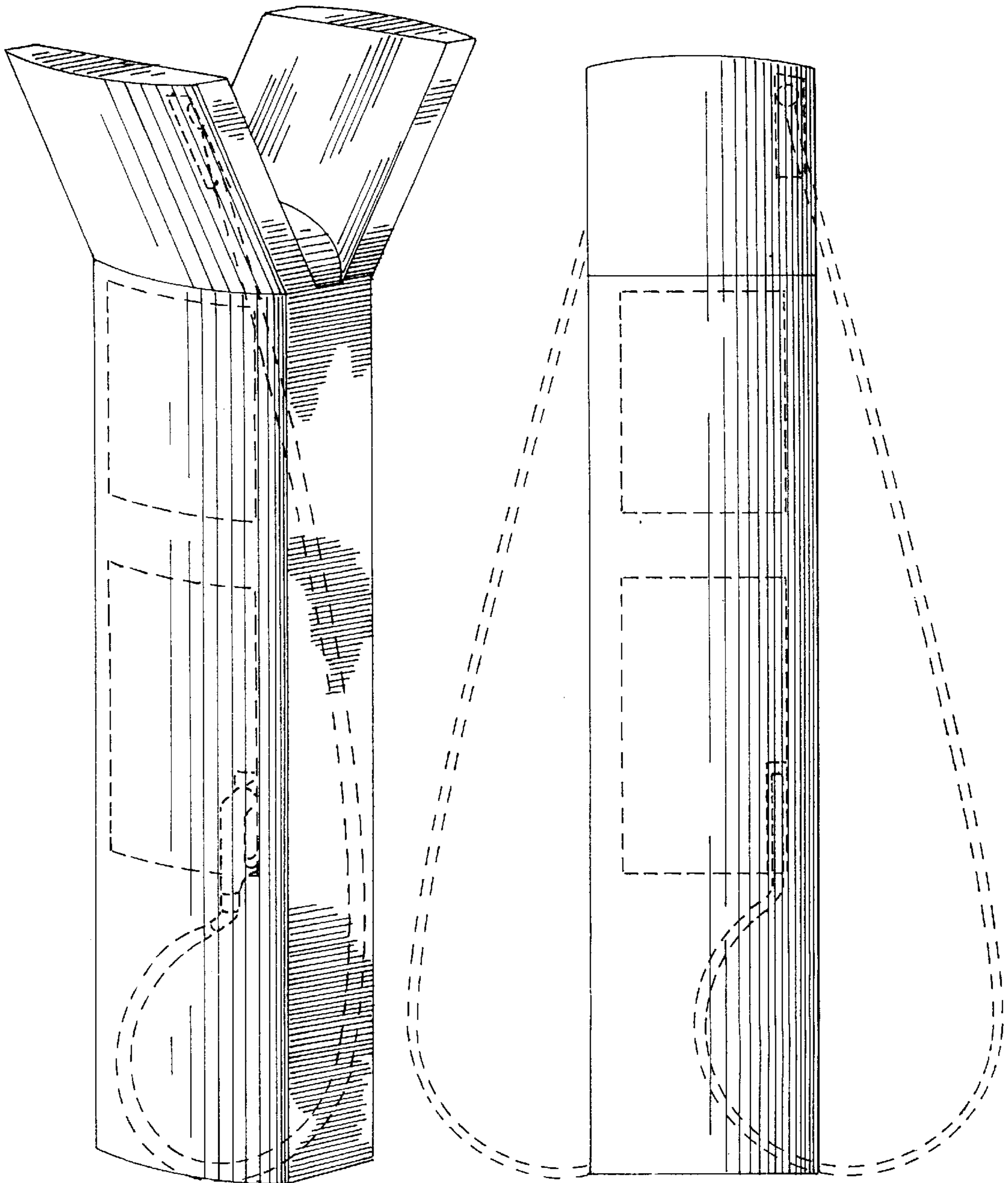

FIG. 1

FIG. 2

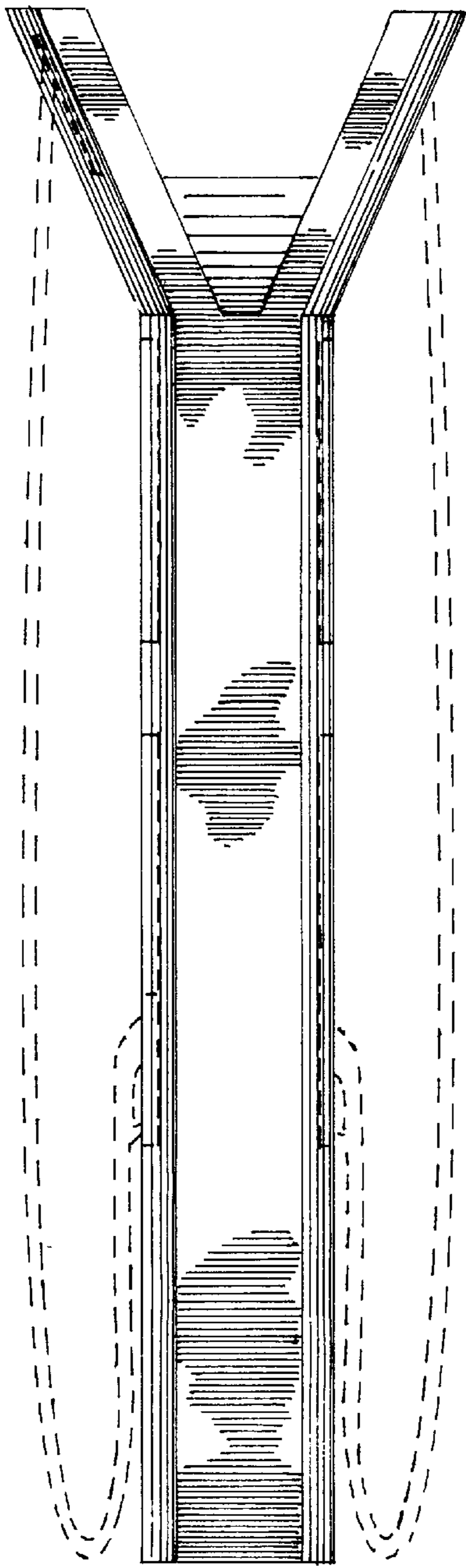

FIG.3

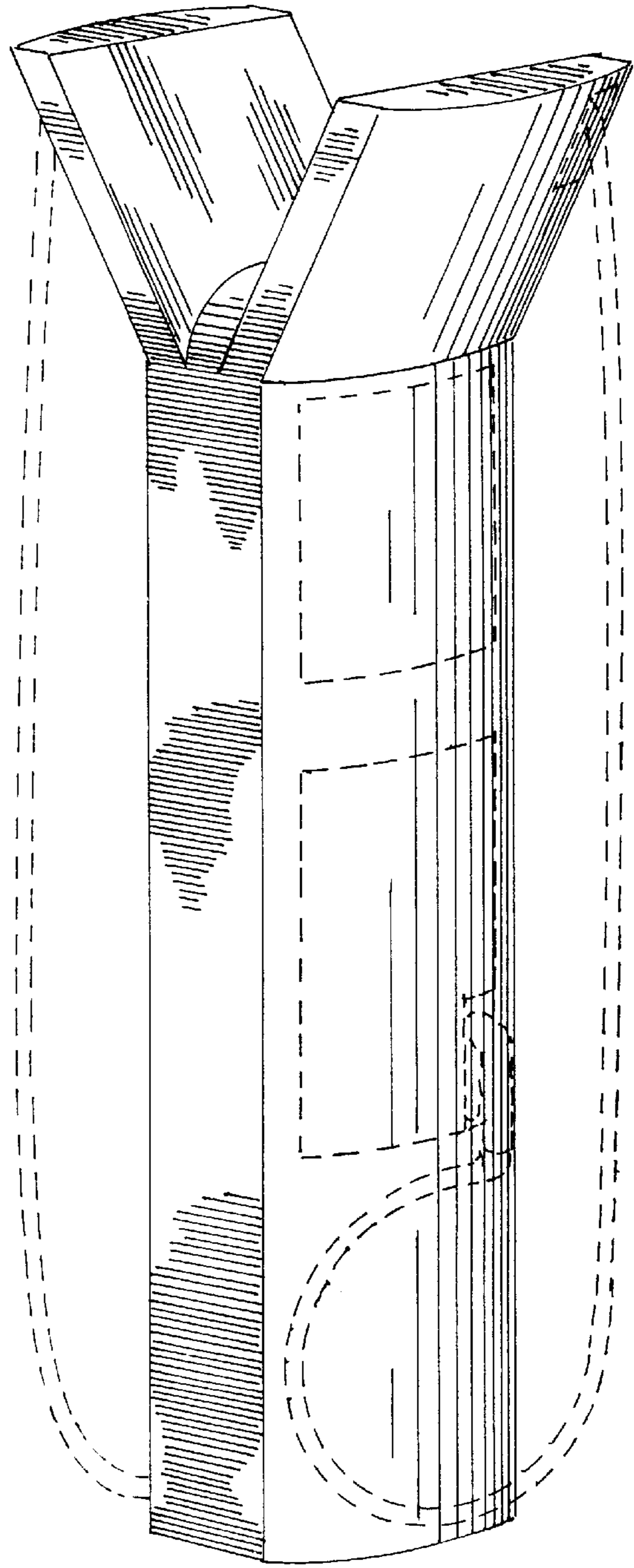

FIG.4

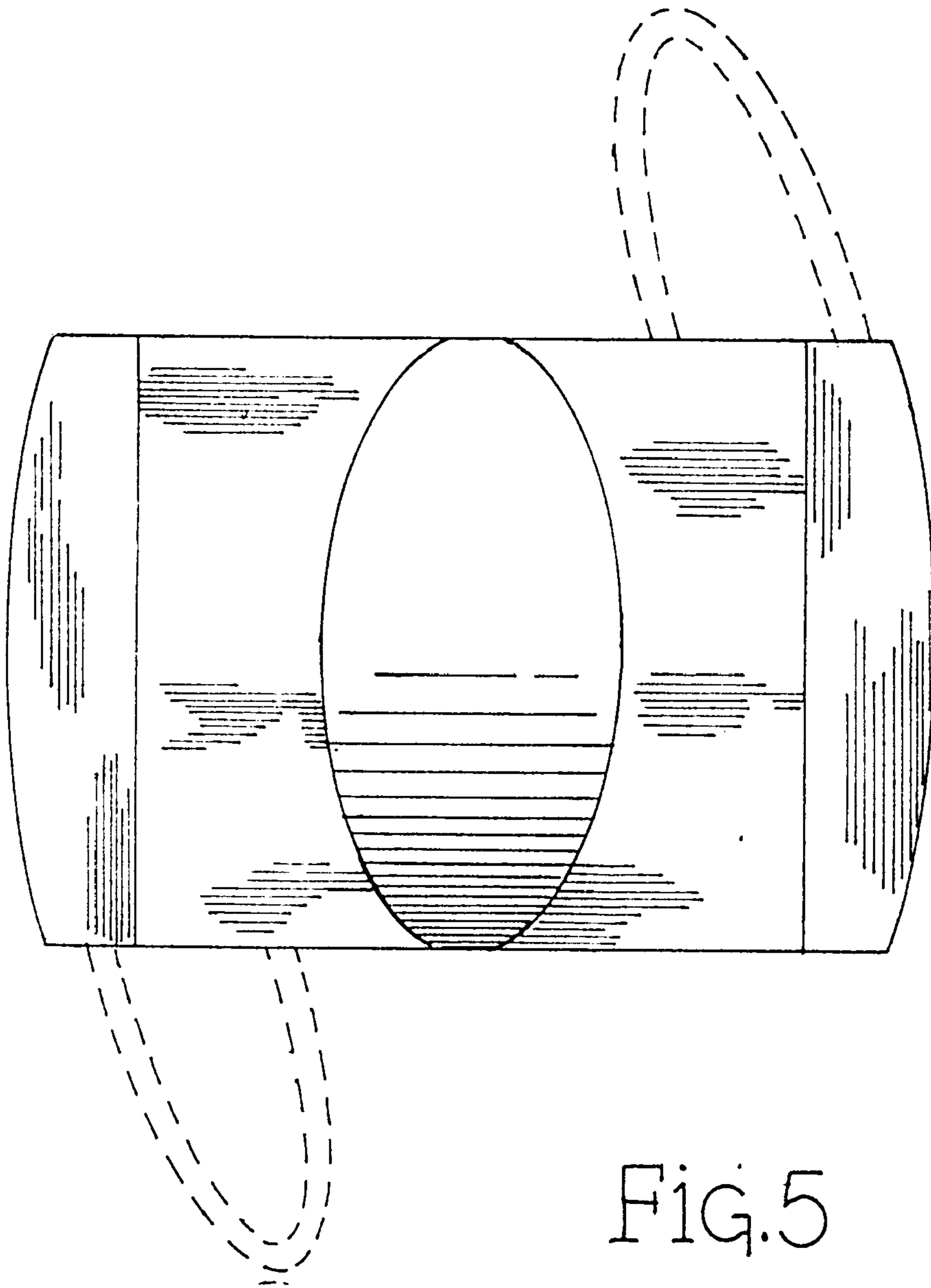

FIG. 5