



US00D414732S

United States Patent [19] Redmond

[11] **Patent Number: Des. 414,732**
[45] **Date of Patent: ** Oct. 5, 1999**

[54] **HITCH ASSEMBLY FOR TRAILER**

[76] Inventor: **Joseph R. Redmond**, 143 Winchell Dr.,
Syracuse, N.Y. 13209-1447

[**] Term: **14 Years**

[21] Appl. No.: **29/098,380**

[22] Filed: **Dec. 28, 1998**

Related U.S. Application Data

[63] Continuation-in-part of application No. 29/081,167, Dec.
23, 1997, Pat. No. Des. 407,358.

[51] **LOC (6) Cl.** **12-16**

[52] **U.S. Cl.** **D12/162**

[58] **Field of Search** D12/162, 400,
D12/408; 280/414.1, 414.2, 476.1, 504,
505, 433, 434, 491.1-491.4, 423.1, 425.1,
425.2

[56] **References Cited**

U.S. PATENT DOCUMENTS

D. 354,263 1/1995 Clark et al. D12/162

D. 357,888 5/1995 Geddes D12/408 X
D. 365,315 12/1995 Parker, Jr. D12/162
D. 399,803 10/1998 Hilmen D12/162
3,717,364 2/1973 McClive 280/414.1

Primary Examiner—Doris V. Coles
Assistant Examiner—Stacia Sinuik
Attorney, Agent, or Firm—Dougherty & Associates

[57] **CLAIM**

The ornamental design for hitch assembly for trailer, as shown and described.

DESCRIPTION

FIG. 1 is a perspective view of my hitch assembly for trailer showing my new design;
FIG. 2 is a reduced top view thereof;
FIG. 3 is a reduced left side view of FIG. 2;
FIG. 4 is a reduced front elevational view thereof, the rear view being a mirror image;
FIG. 5 is a reduced right side elevational view thereof; and,
FIG. 6 is a reduced bottom view thereof.
The broken line showing of environment is for illustrative purposes only and forms no part of the claimed design.

1 Claim, 2 Drawing Sheets

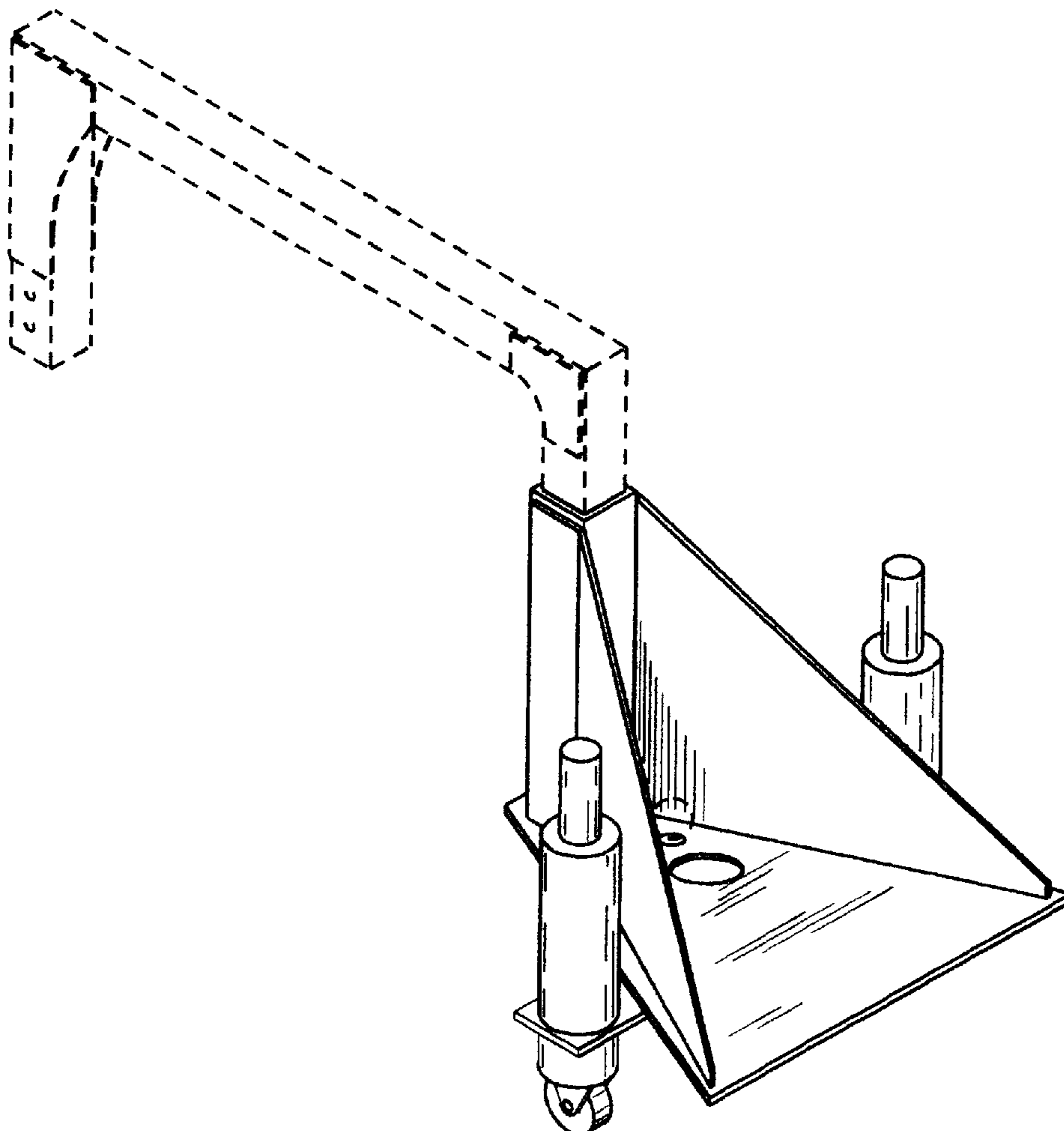

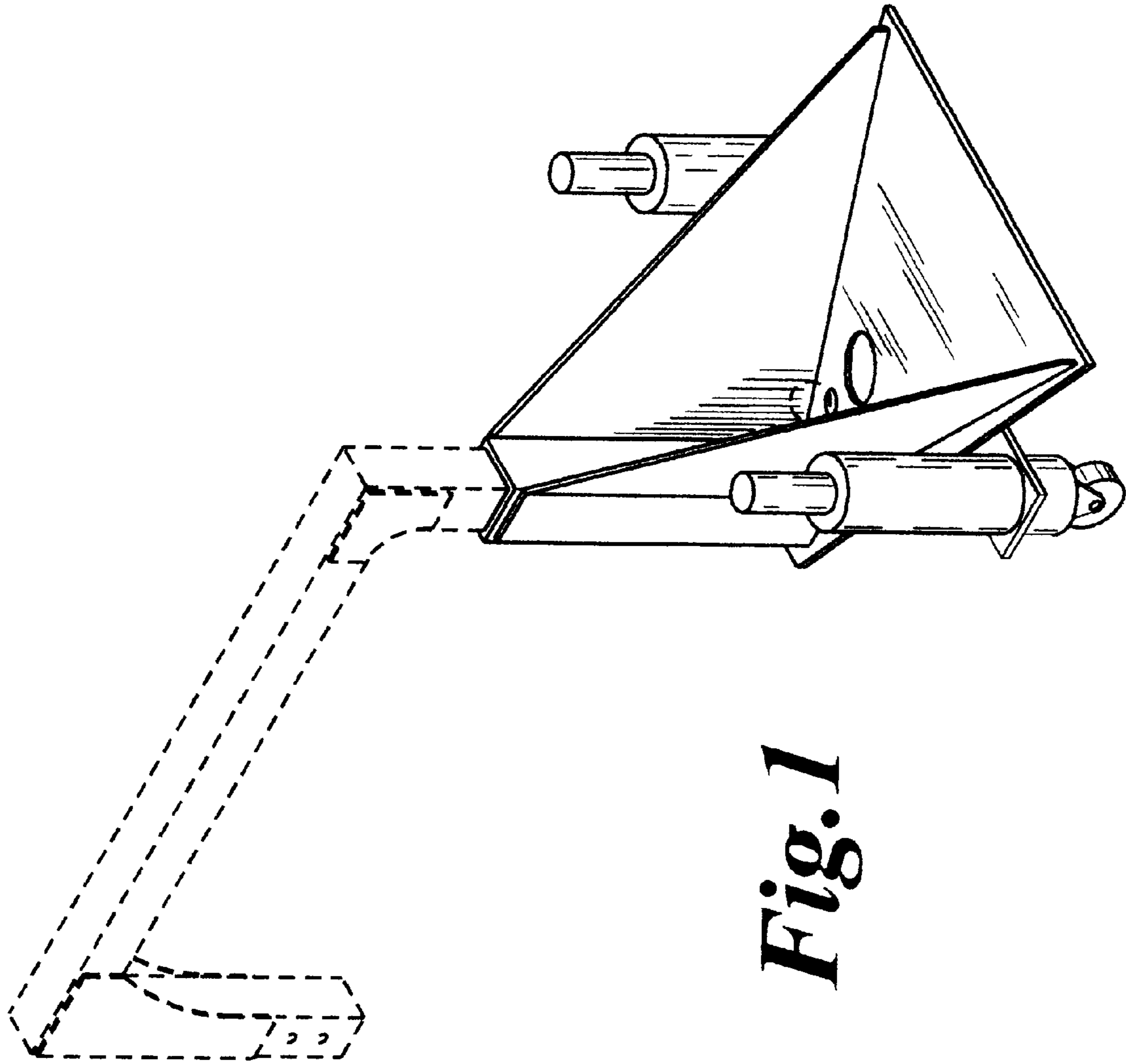

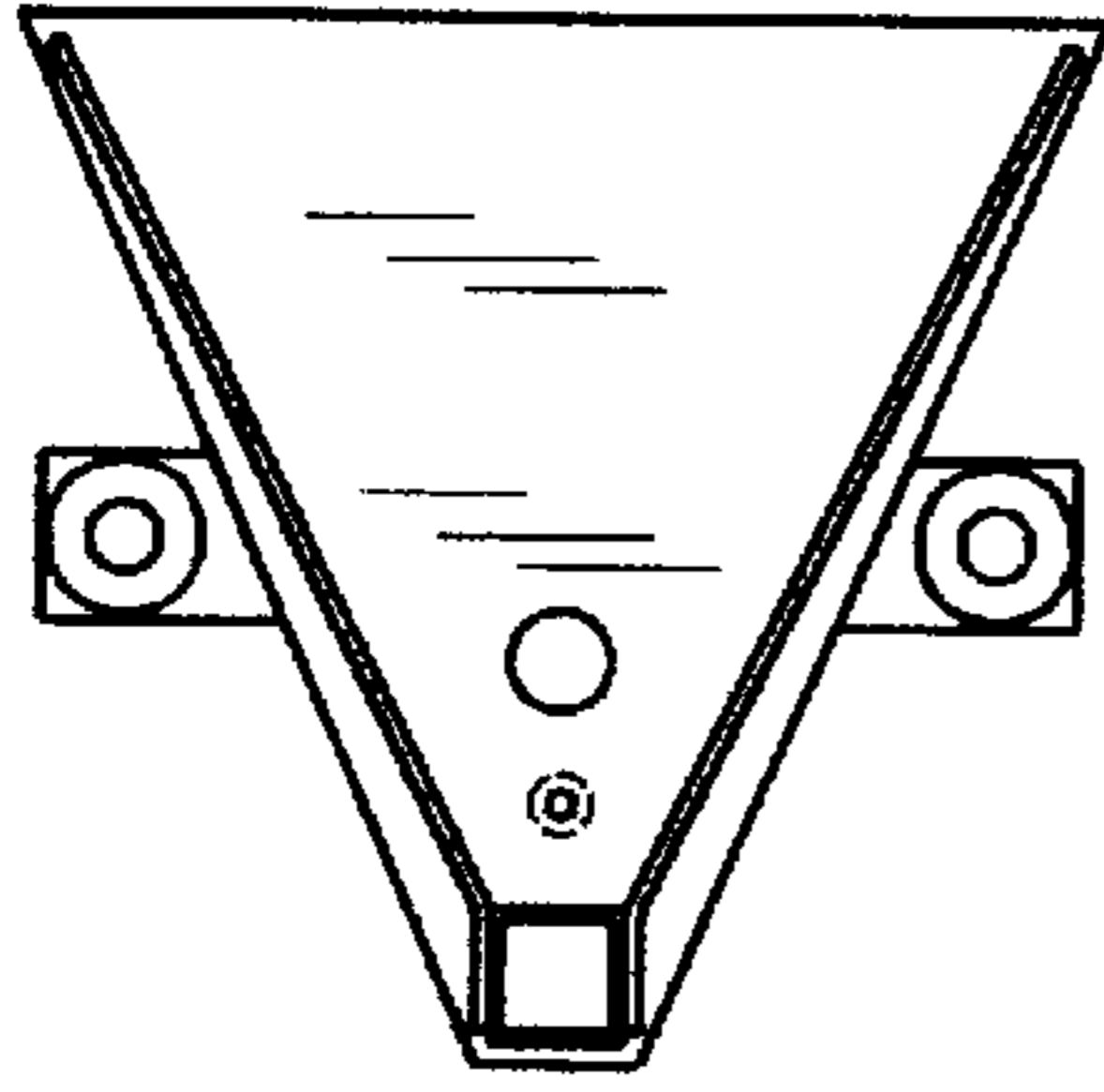

Fig. 2

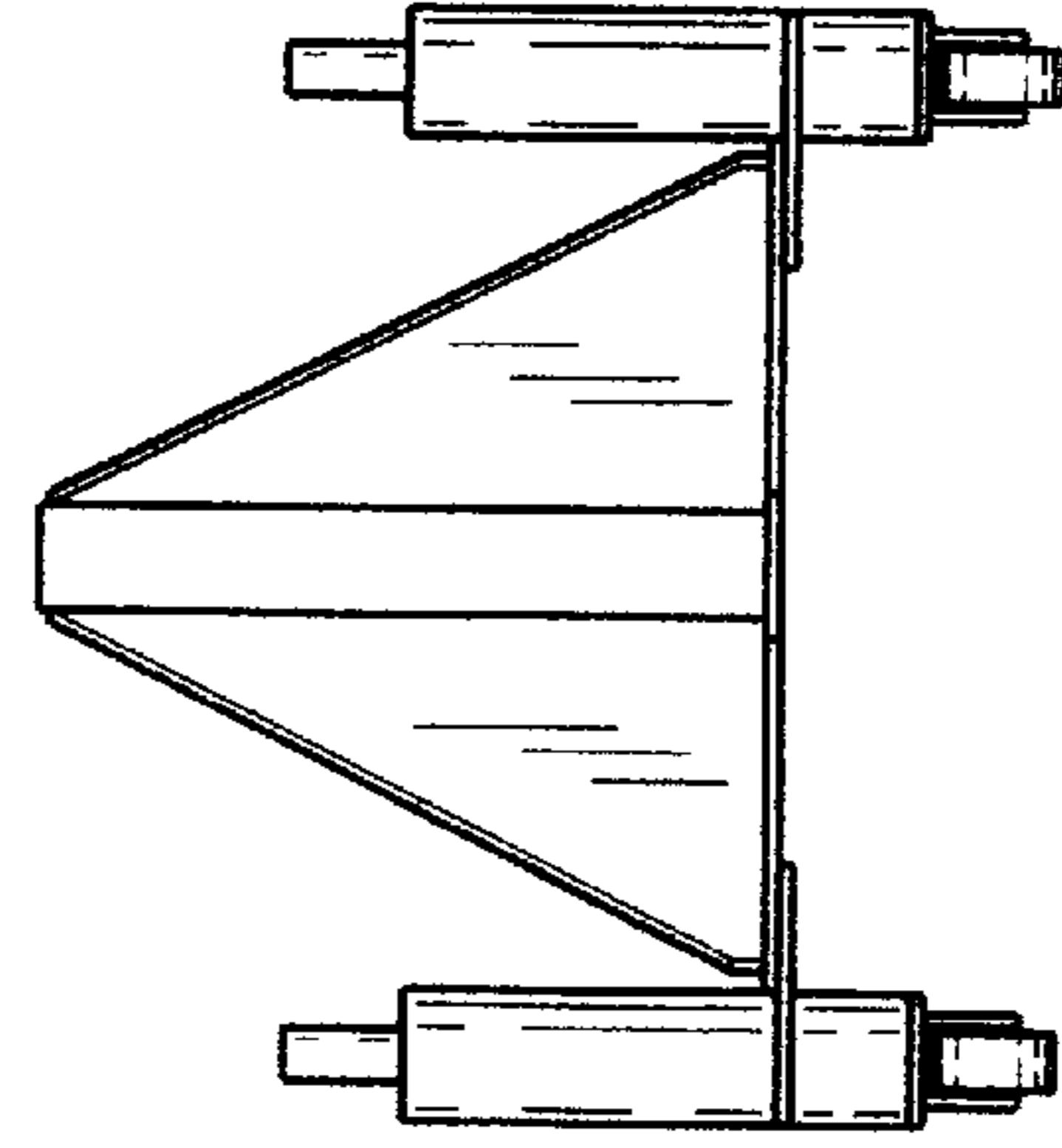

Fig. 3

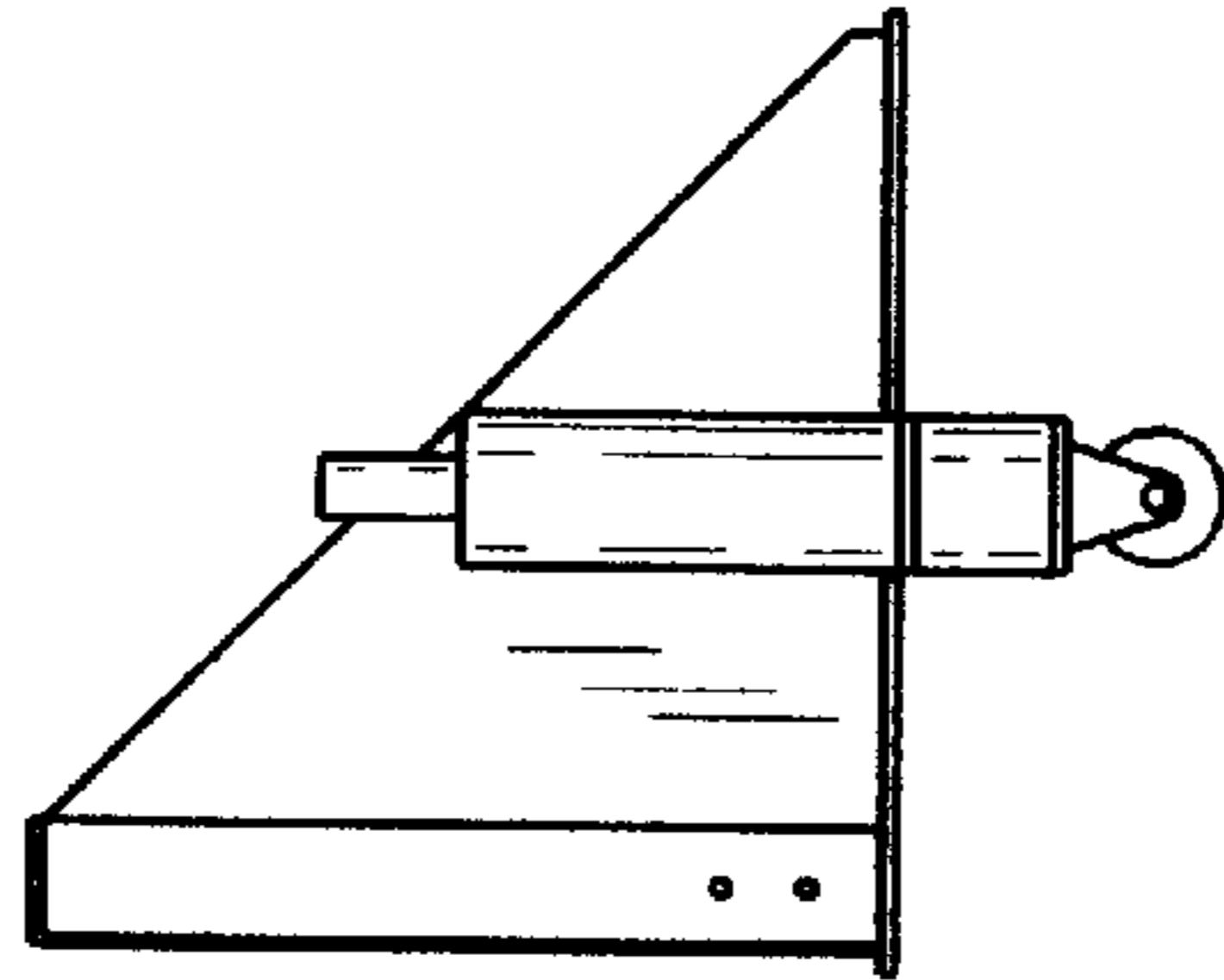

Fig. 4

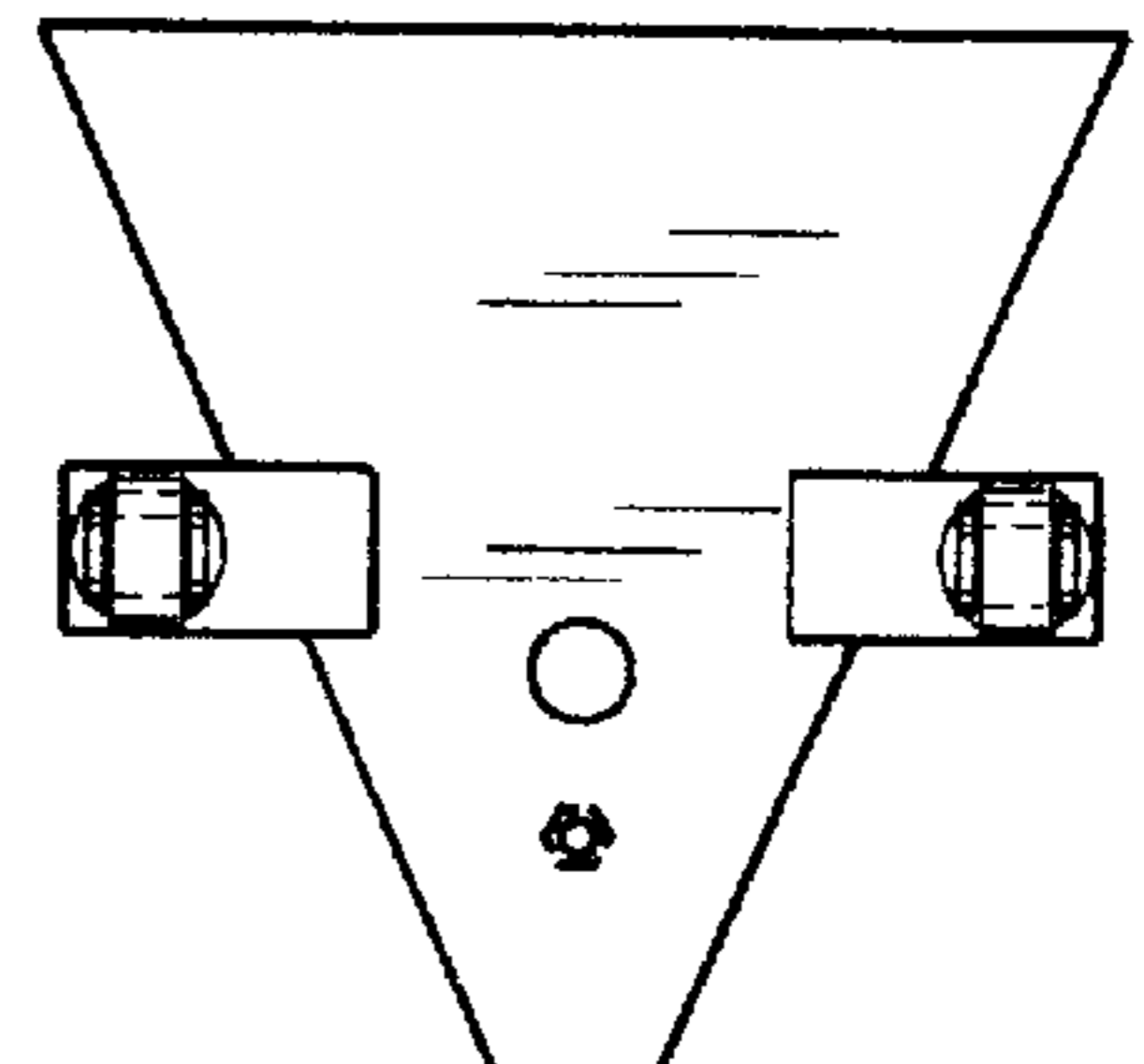

Fig. 6

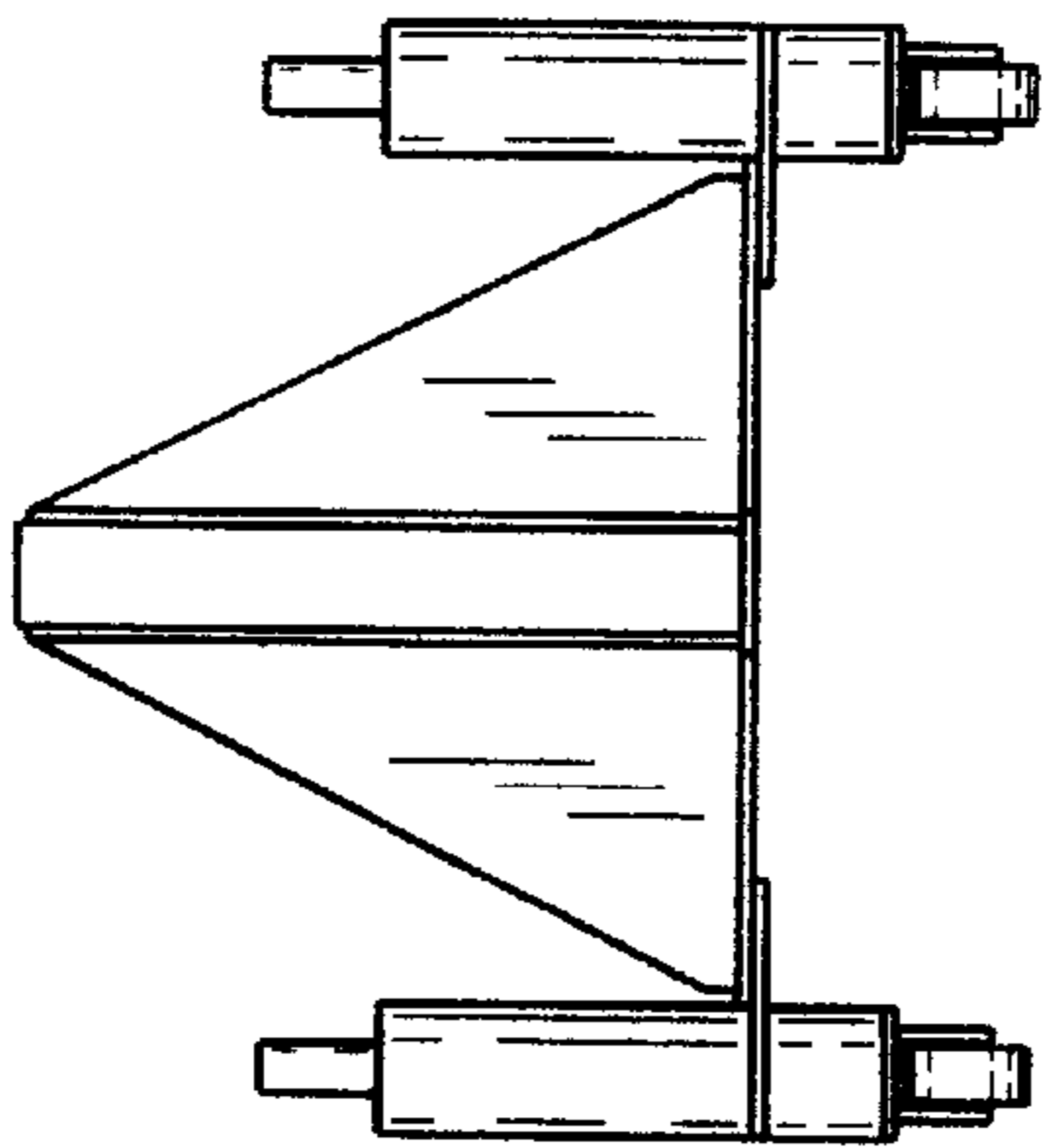

Fig. 5