



US00D414617S

United States Patent [19]

[11] **Patent Number: Des. 414,617**

Foussianes

[45] **Date of Patent: ** Oct. 5, 1999**

[54] **CHAIR**

[76] Inventor: **Nicholas B. Foussianes**, 3150 N. Lake Shore Dr., Unit 26C, Chicago, Ill. 60657

[**] Term: **14 Years**

[21] Appl. No.: **29/095,983**

[22] Filed: **Nov. 3, 1998**

[51] **LOC (6) Cl. 06-01**

[52] **U.S. Cl. D6/372; D6/379**

[58] **Field of Search D6/334, 371, 372, D6/373, 374, 379, 380, 500, 501, 502; 297/451.3, 451.7**

[56] **References Cited**

U.S. PATENT DOCUMENTS

D. 150,076	6/1948	Logan	D6/372
D. 245,952	10/1977	Lüthy	D6/372
D. 251,578	4/1979	Ruf	D6/372
D. 278,285	4/1985	Lowrey	D6/372
D. 366,776	2/1996	Pasin	D6/372

OTHER PUBLICATIONS

Wassily Model B3, 1925—Marcel Breuer—Published—1000 Chairs by Charlotte & Peter Fiell © 1997 Benedict Taschen Verlag GmbH.

Model No. S33, 1926 —Mart Stam—Published—1000 Chairs by Charlotte & Peter Fiell © 1997 Benedict Taschen Verlag GmbH.

Model No. MR10, 1927 Ludwig Mies Van Der Rohe A Critical Biography by Franz Schulze © 1985 Franz Schulze. Brno, 1929/1930—Ludwig Mies Van Der Rohe—Published—1000 Chairs by Charlotte & Peter Fiell © 1997 Benedict Taschen Verlag GmbH.

Model MR 50, 1929/1930—Ludwig Miles Van Der Rohe—A Critical Biography by Franz Schulze © 1985 Franz Schulze.

Model B5, 1926,1927—Marcel Breuer—Published—1000 Chairs by Charlotte & Peter Fiell © 1997 Benedict Taschen Verlag GmbH.

Cantilever Stool, 1927—Marcel Breuer—Published—1000 Chairs by Charlotte & Peter Fiell © 1997 Benedict Taschen Verlag GmbH.

Model B33, 1927/1928—Marcel Breuer—Published—1000 Chairs by Charlotte & Peter Fiell © 1997 Benedict Taschen Verlag GmbH.

Model B55, 1928/1929—Marcel Breuer—Published—1000 Chairs by Charlotte & Peter Fiell © Benedict Taschen Verlag GmbH.

Model B35, 1928/1929—Marcel Breuer—Published—1000 Chairs by Charlotte & Peter Fiell © 1997 Benedict Taschen Verlag GmbH.

Non-Conformist, 1926—Eileen Gray—Published—1000 Chairs by Charlotte & Peter Fiell © 1997 Benedict Taschen Verlag GmbH.

Roquebrune, 1932—Eileen Gray—Published—1000 Chairs by Charlotte & Peter Fiell © Benedict Taschen Verlag GmbH.

Primary Examiner—Gary D. Watson

Attorney, Agent, or Firm—Wildman, Harrold, Allen & Dixon; Thomas J. Ring

[57] **CLAIM**

The ornamental design for a chair, as shown.

DESCRIPTION

FIG. 1 is a perspective view of a chair embodying my novel design.

FIG. 2 is a top plan view of the chair.

FIG. 3 is a front elevational view of the chair.

FIG. 4 is a side elevational view of the chair taken from the left in FIG. 3.

FIG. 5 is a side elevational view of the chair taken from the right in FIG. 3; and,

FIG. 6 is a rear elevational view of the chair.

1 Claim, 3 Drawing Sheets

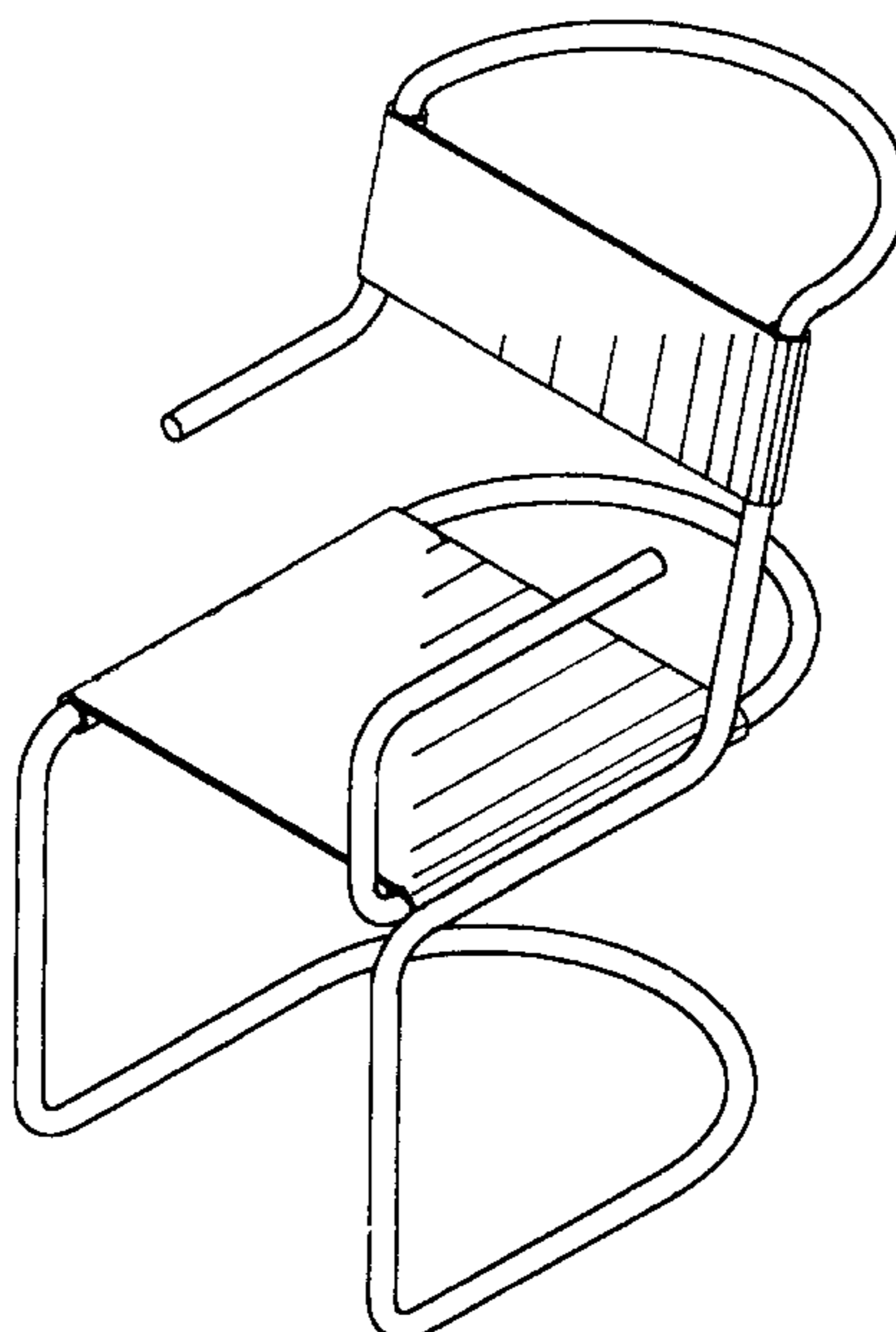

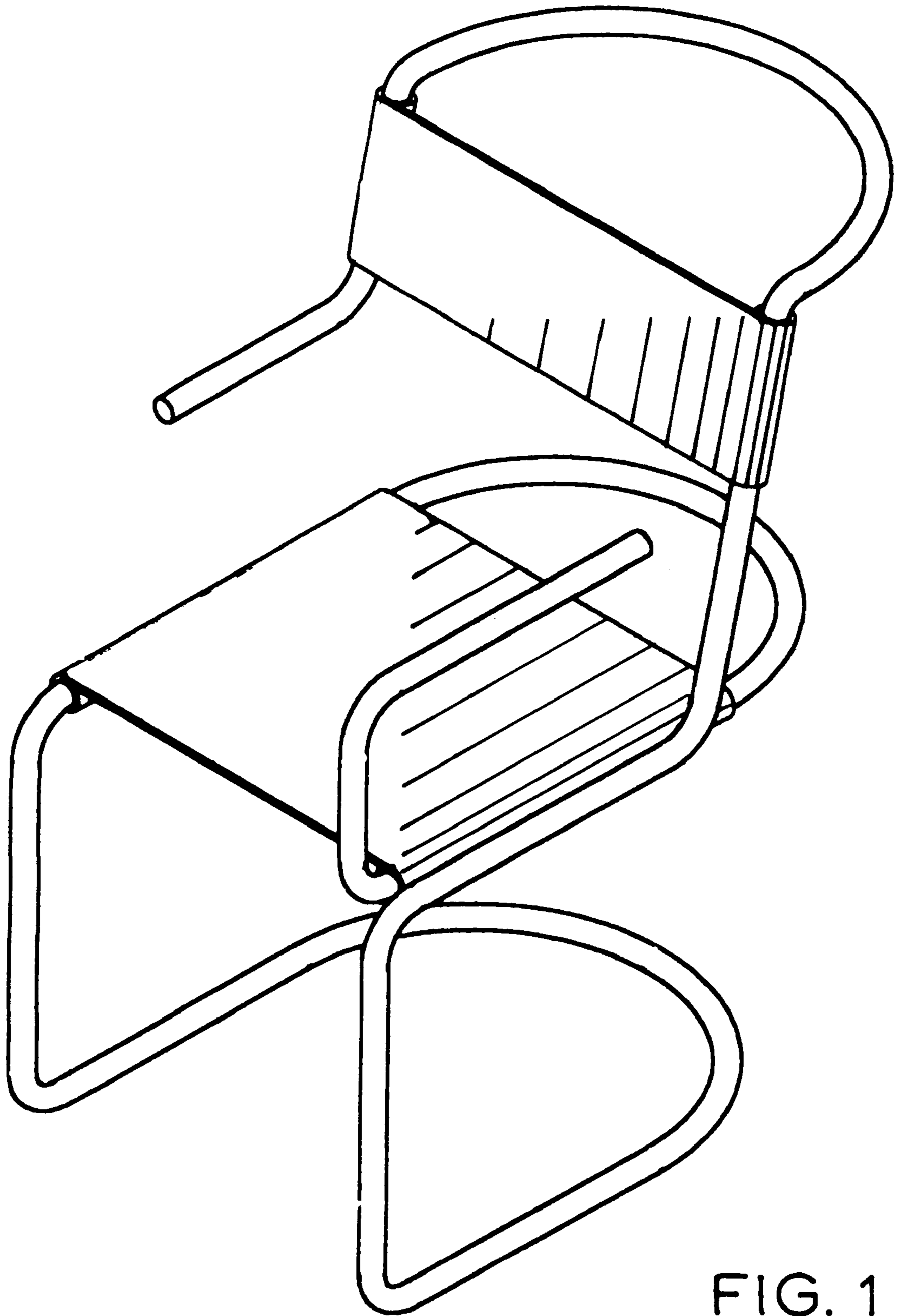

FIG. 1

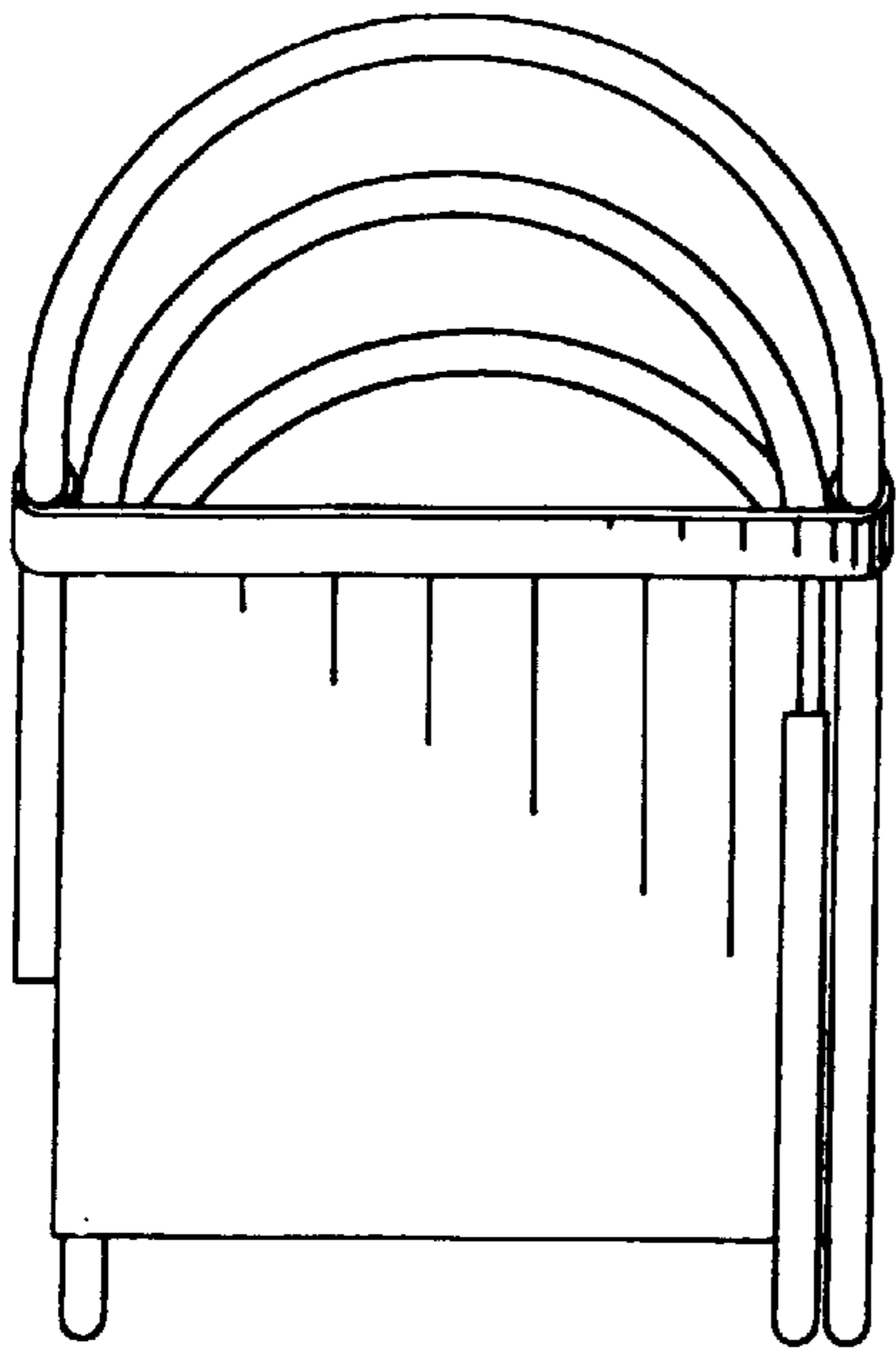

FIG. 2

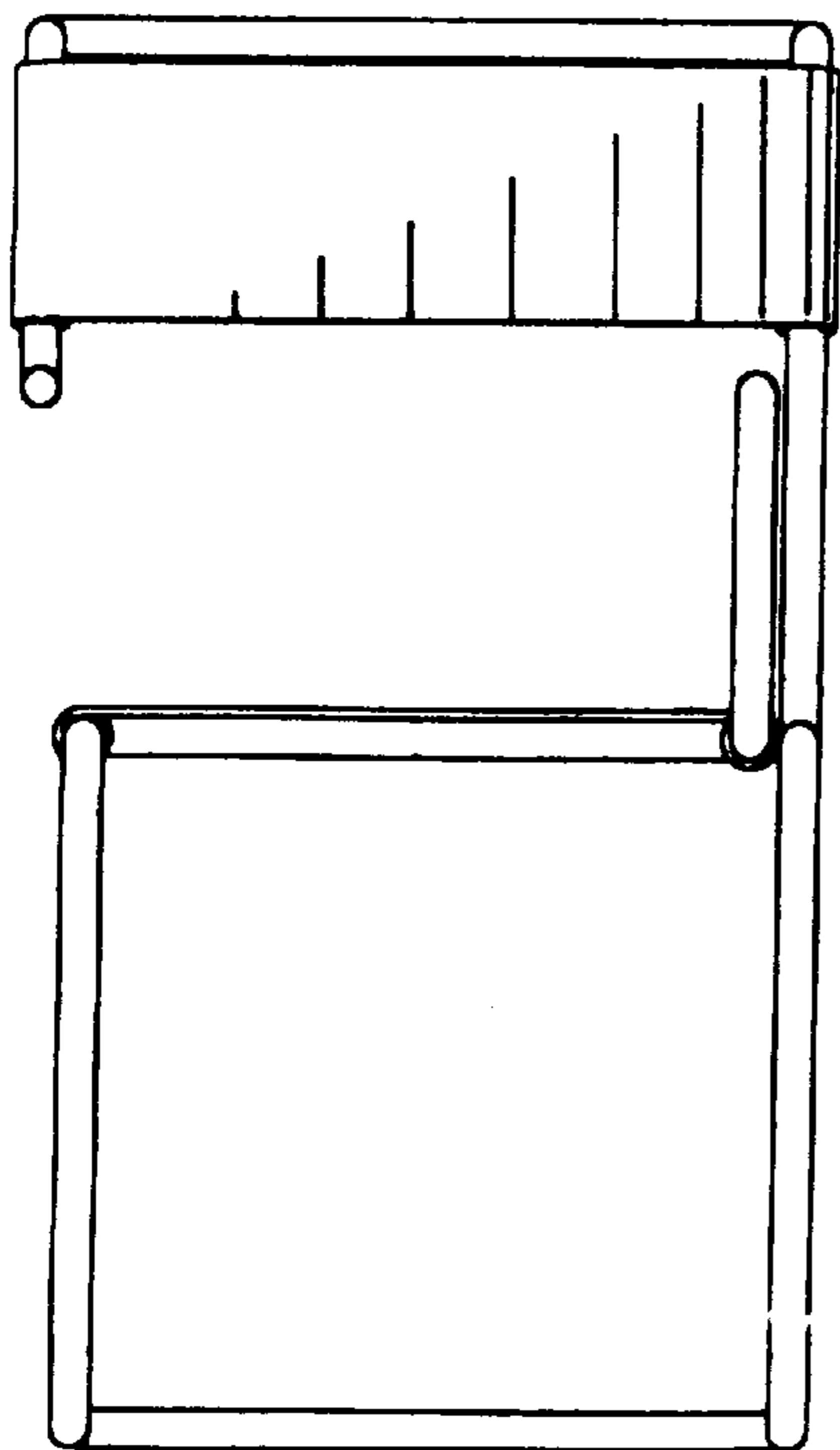

FIG. 3

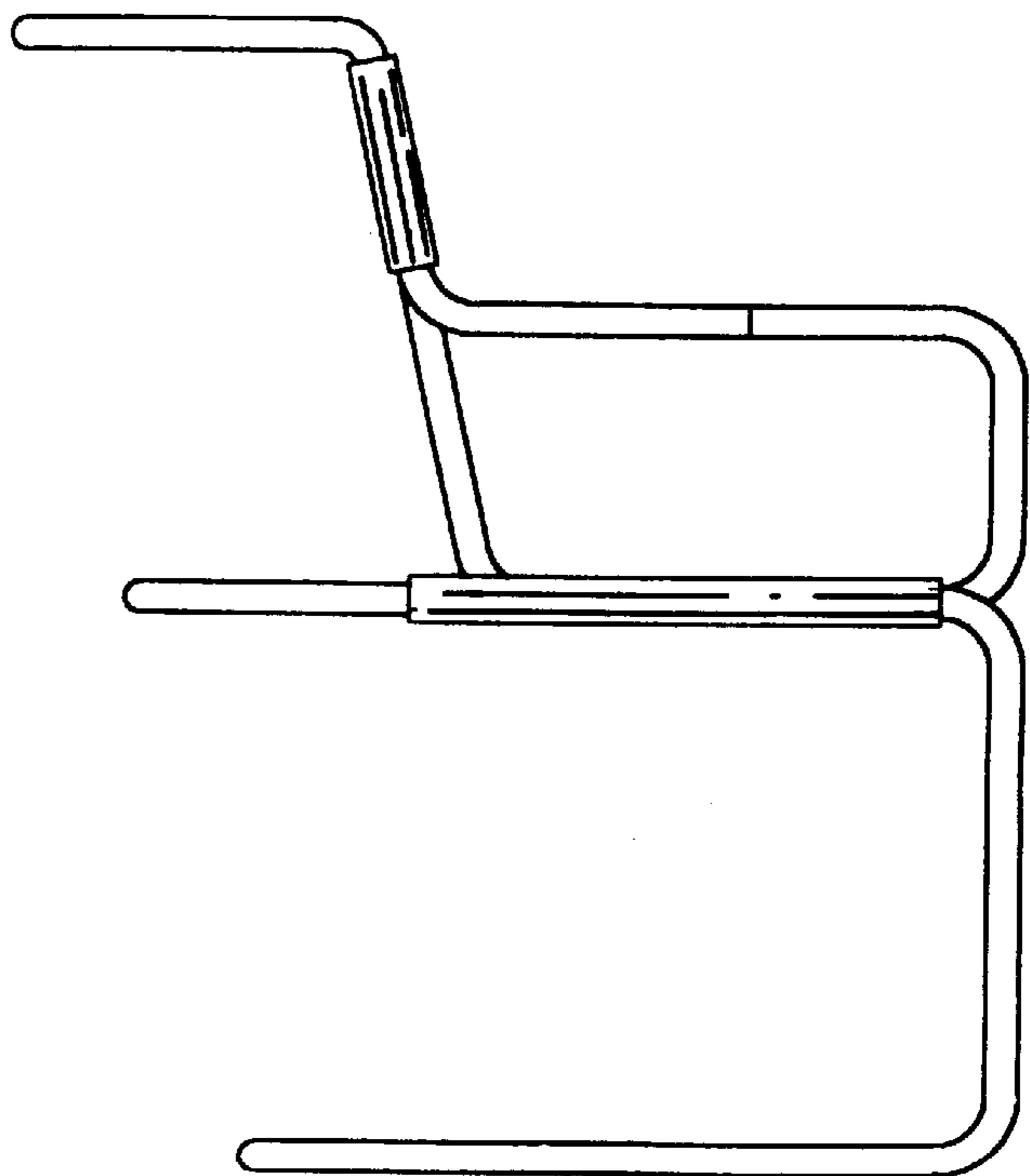

FIG. 4

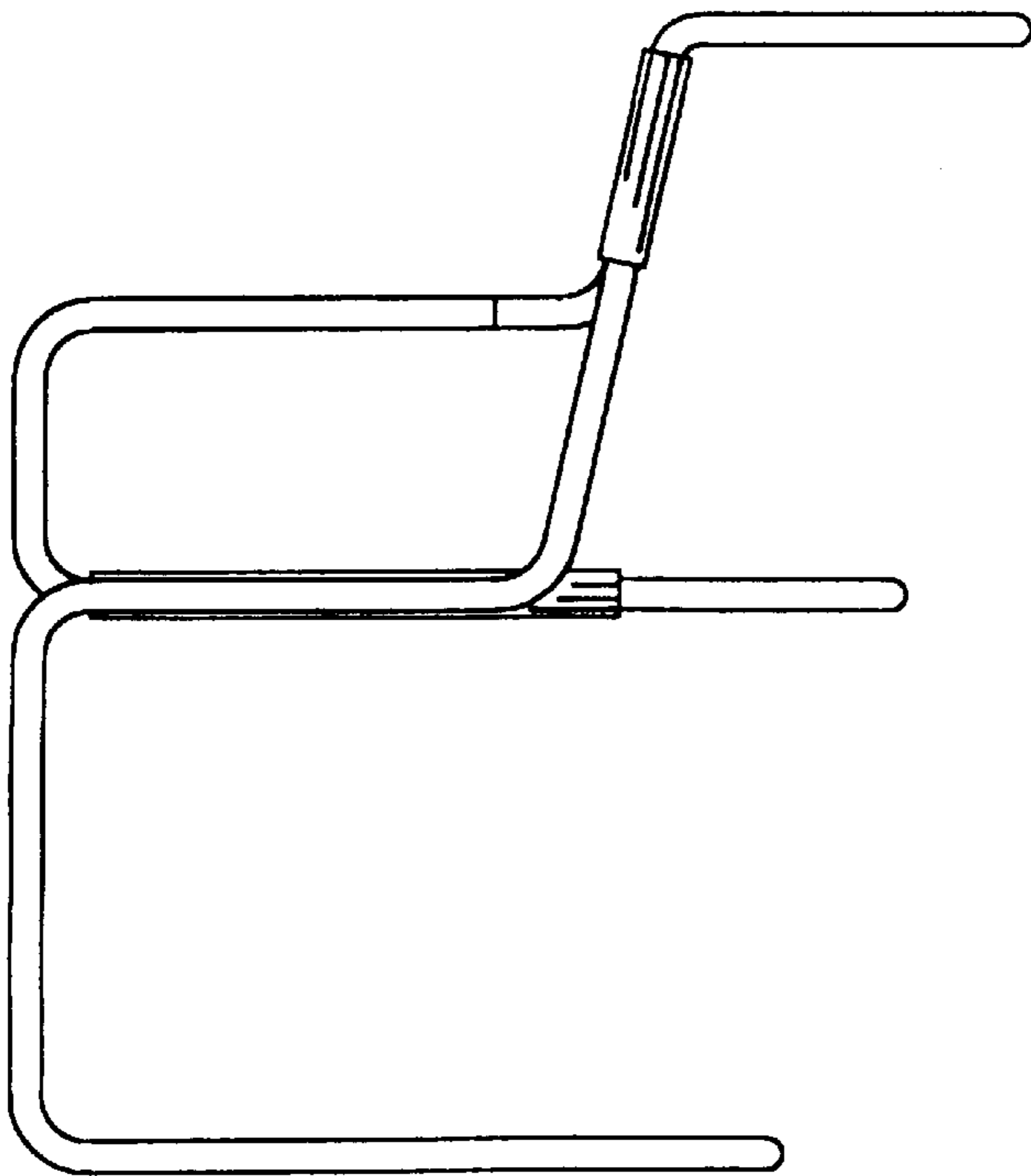

FIG. 5

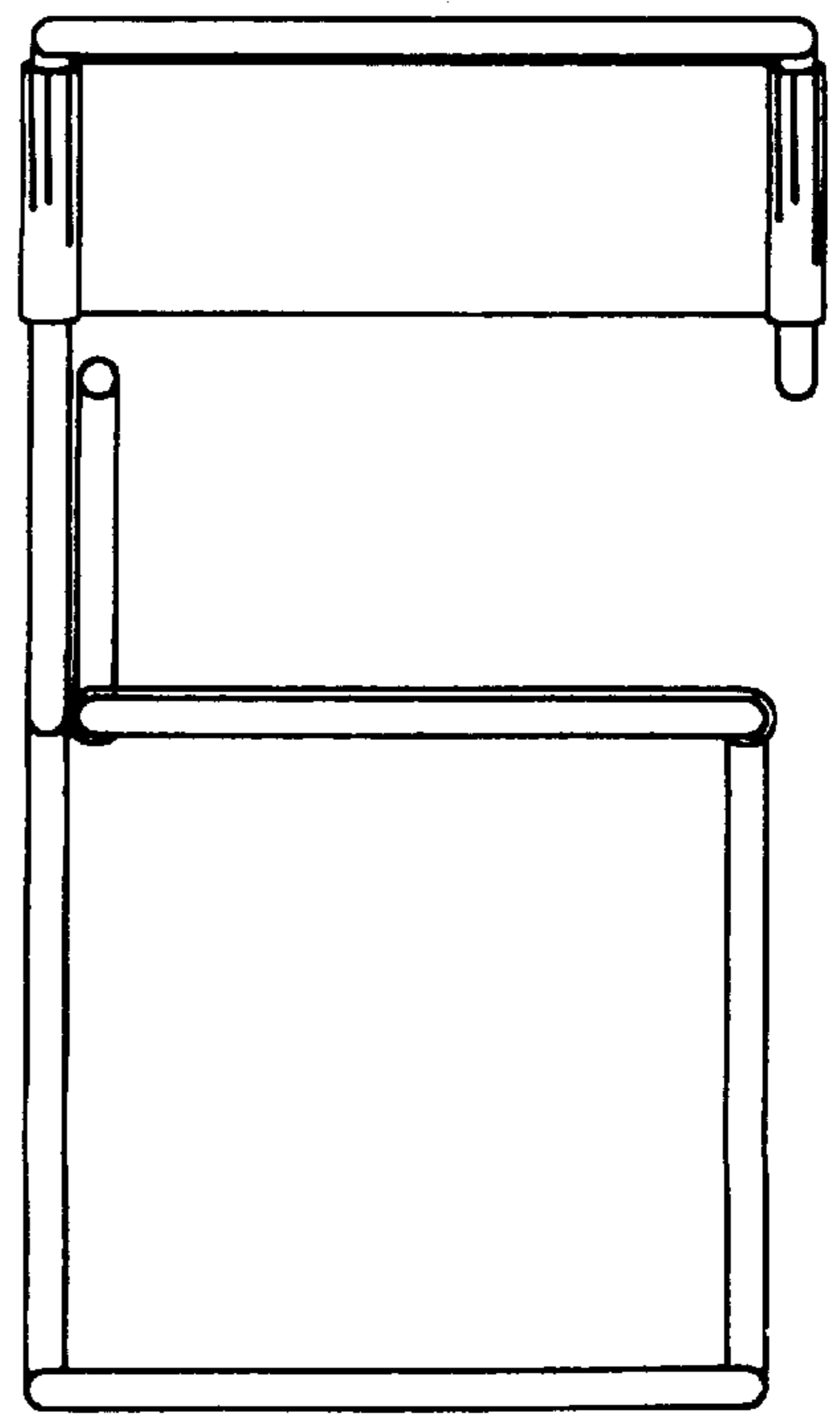

FIG. 6