



US00D414138S

United States Patent [19]
McKinney

[11] **Patent Number: Des. 414,138**

[45] **Date of Patent: ** Sep. 21, 1999**

- [54] **UTILITY DUMP TRUCK BODY**
- [75] Inventor: **Bobby Ray McKinney**, Fort Payne, Ala.
- [73] Assignee: **The Heil Co.**, Chattanooga, Tenn.
- [**] Term: **14 Years**
- [21] Appl. No.: **29/082,871**
- [22] Filed: **Jan. 15, 1998**
- [51] **LOC (6) Cl.** **12-08**
- [52] **U.S. Cl.** **D12/98; D12/15**
- [58] **Field of Search** D12/1, 14-15, D12/98, 93; 296/1 A, 24.1; 298/11, 23 R, 22 R, 22 P; 414/477

- 3,656,800 4/1972 Timmons et al. 296/50
- 3,740,097 6/1973 Parker et al. 298/1 A
- 4,019,781 4/1977 Ray 298/22 J
- 4,741,575 5/1988 Sloan 298/12

Primary Examiner—Nelson C. Holtje
Attorney, Agent, or Firm—Alan Ruderman; Miller & Martin, LLP

[57] **CLAIM**

The ornamental design for a utility dump truck body, as shown and described.

DESCRIPTION

FIG. 1 is a rear perspective view of a utility dump truck body embodying my new design;
FIG. 2 is a side elevational view of one side thereof, the other side being a mirror image;
FIG. 3 is a rear elevational view thereof;
FIG. 4 is a front elevational view thereof;
FIG. 5 is a bottom plan view thereof; and,
FIG. 6 is a top plan view thereof.

- [56] **References Cited**
- U.S. PATENT DOCUMENTS
- D. 346,571 5/1994 Lewellen et al. D12/98
- D. 351,817 10/1994 Lewellen et al. D12/98
- D. 385,224 10/1997 Aros et al. D12/98
- D. 386,722 11/1997 Dunphy D12/93

1 Claim, 5 Drawing Sheets

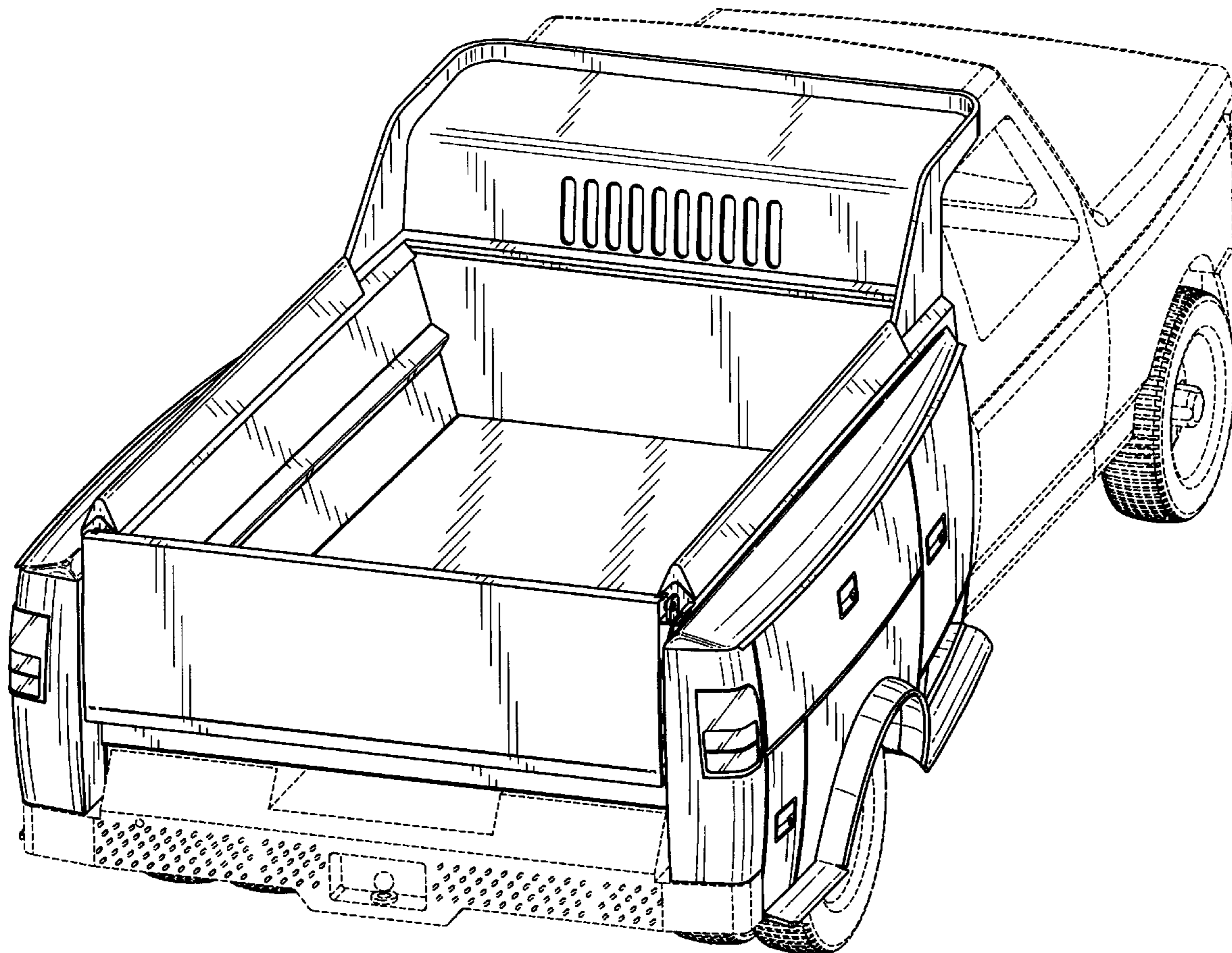

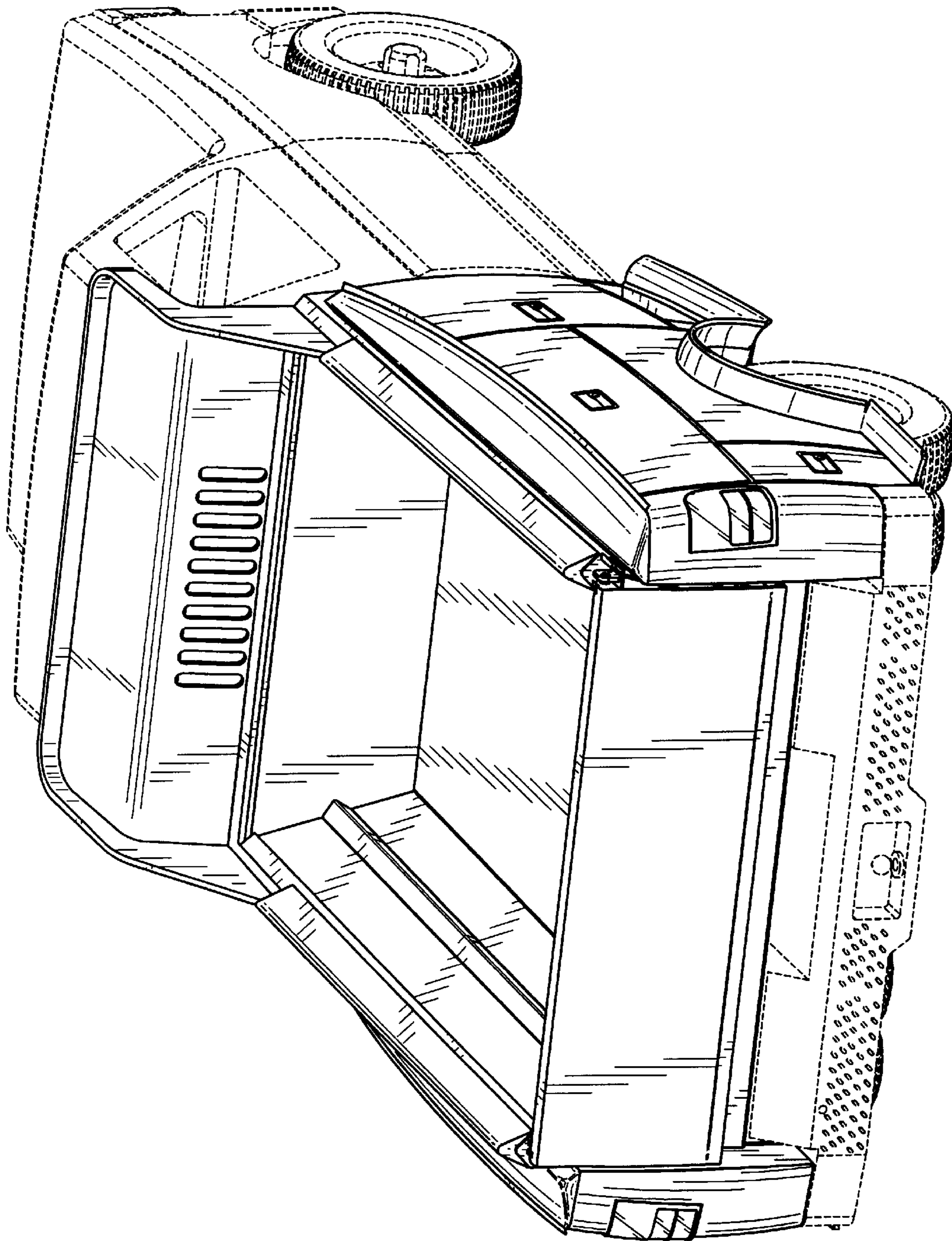

FIG. 1

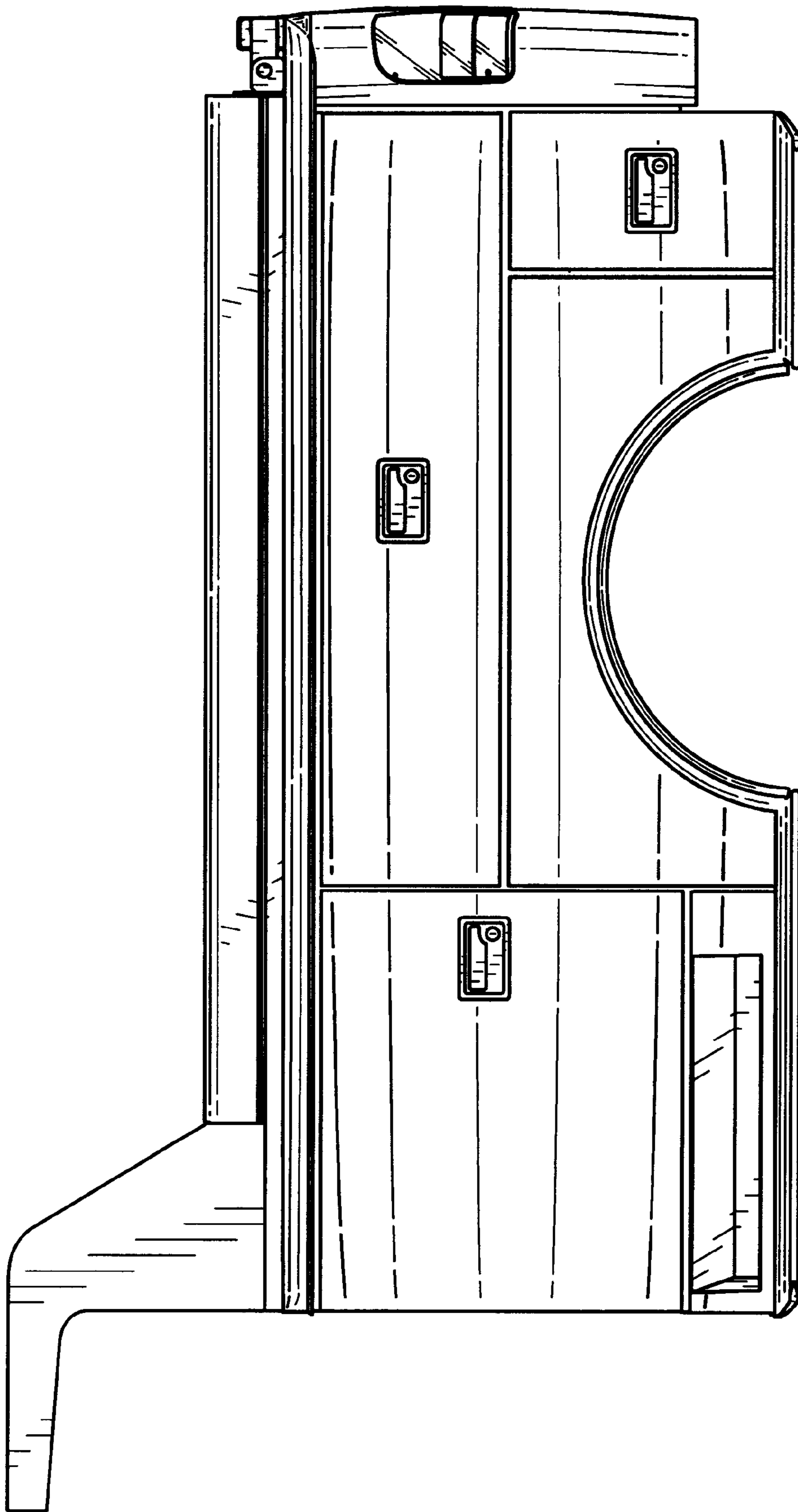

FIG. 2

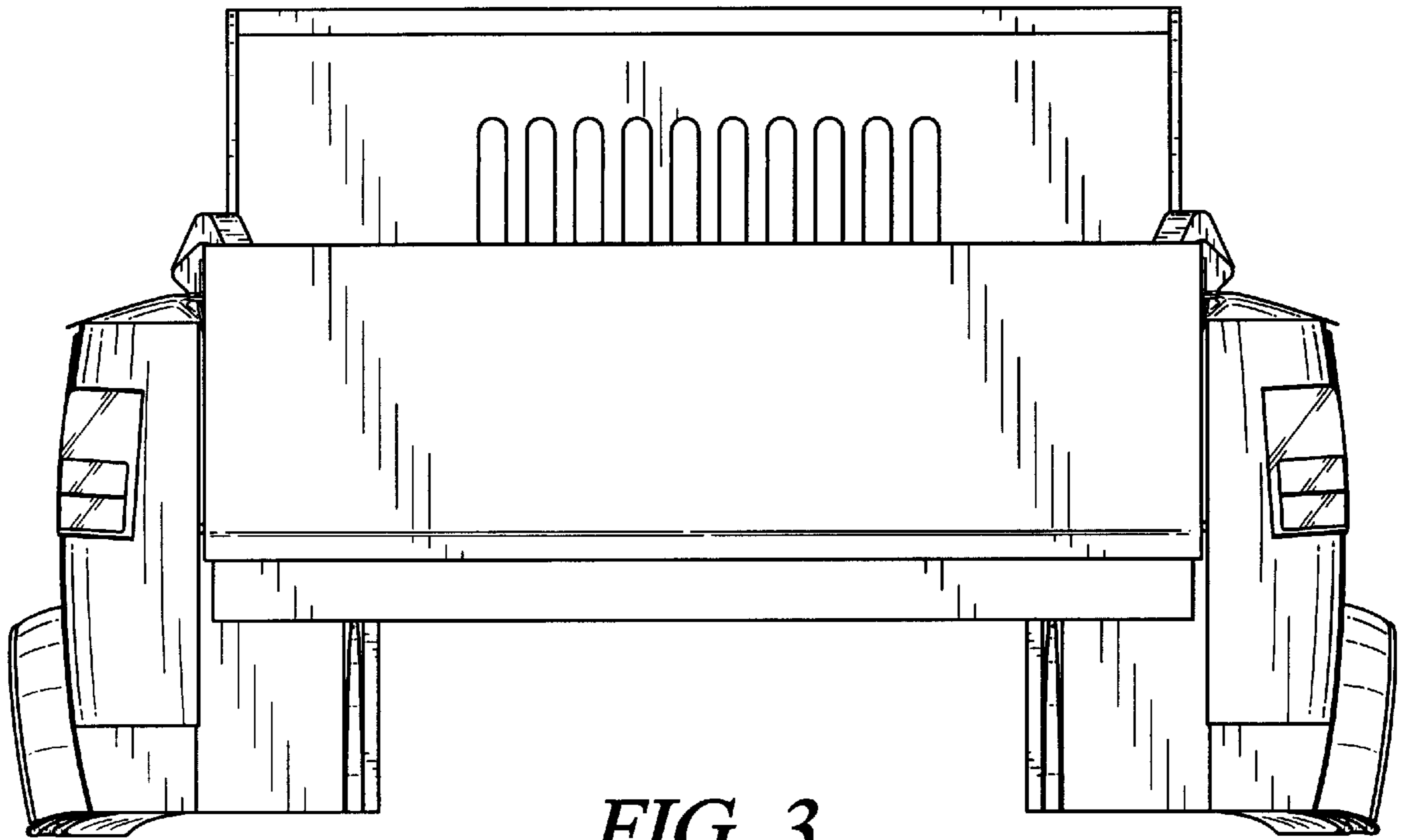

FIG. 3

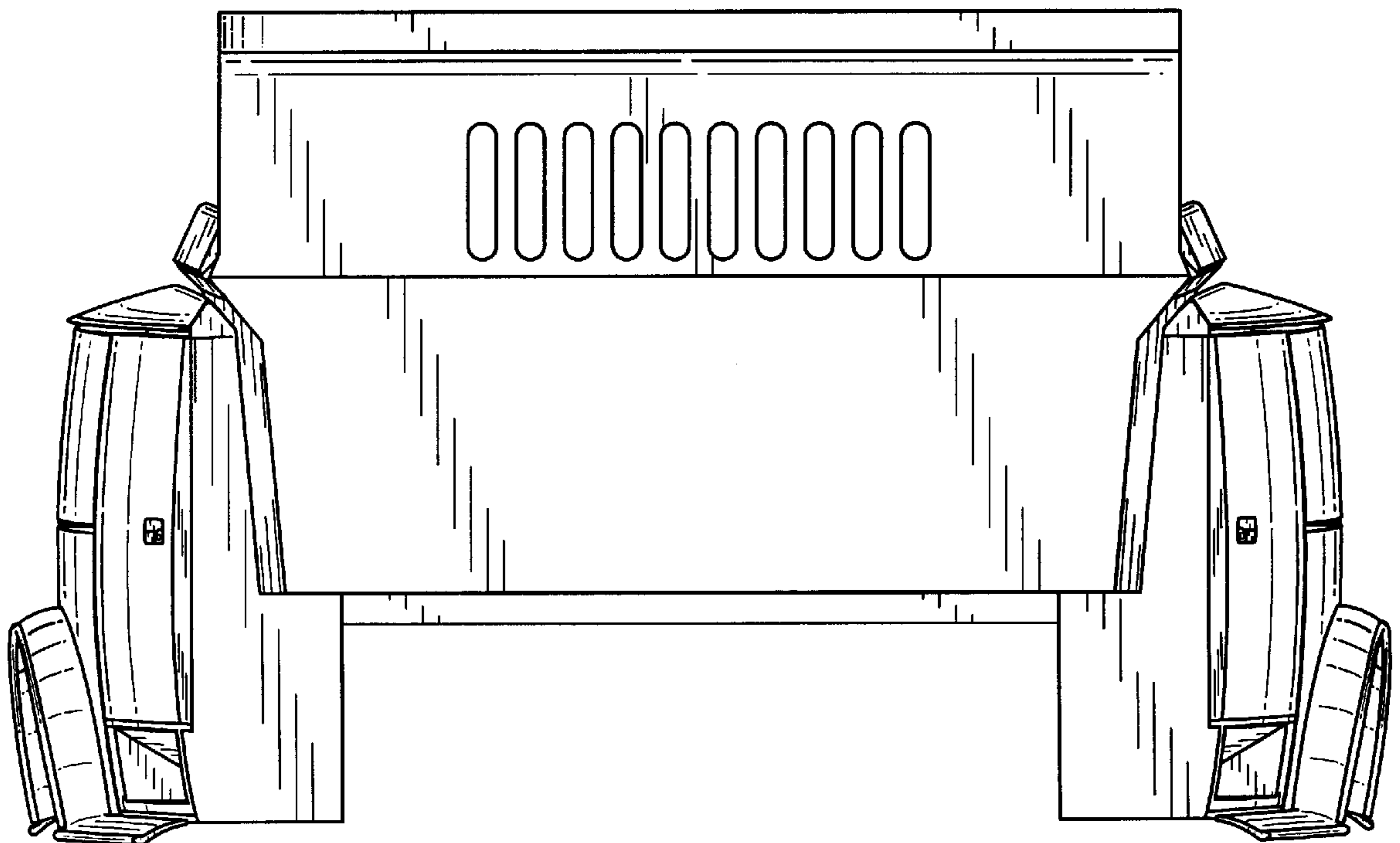

FIG. 4

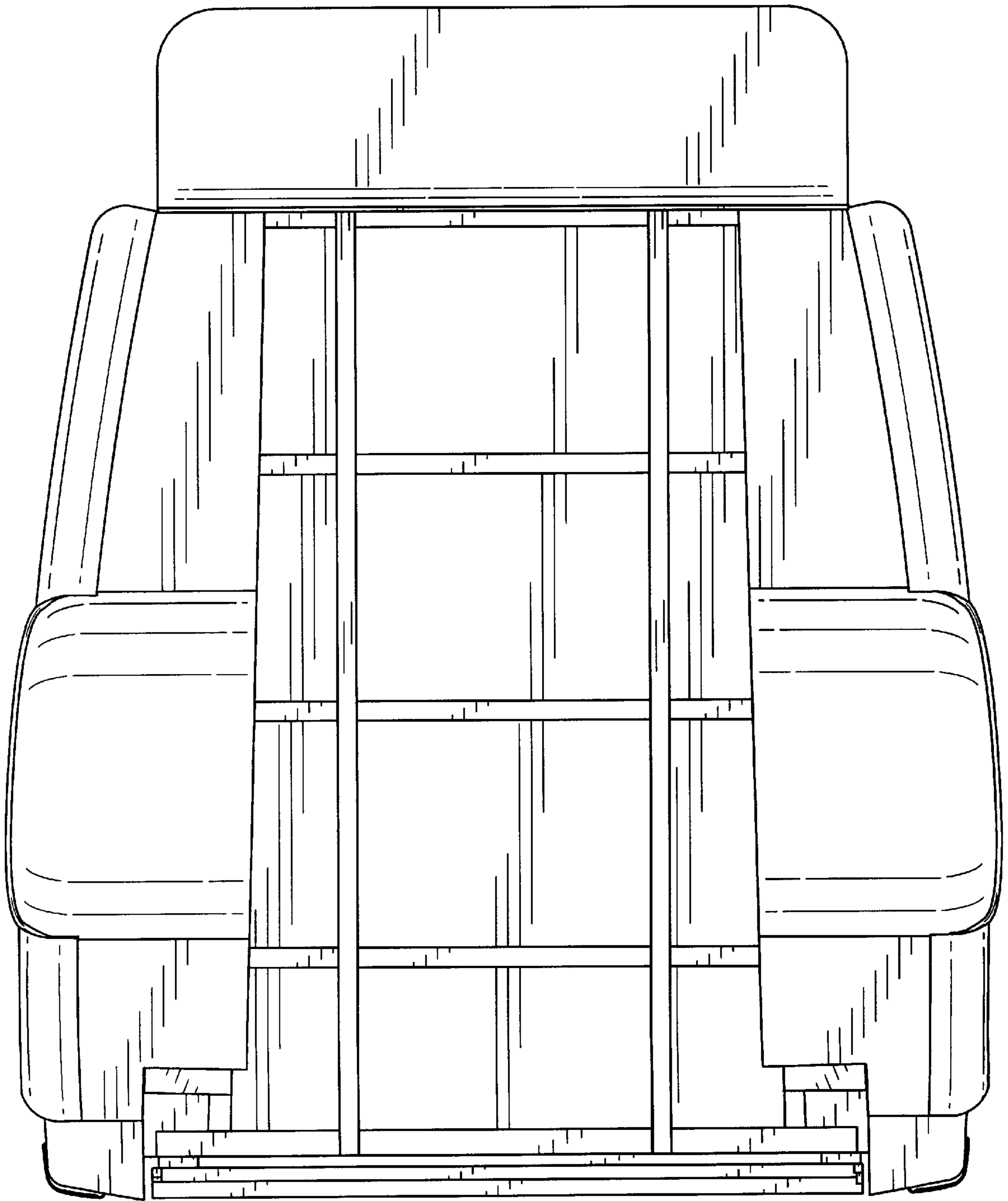

FIG. 5

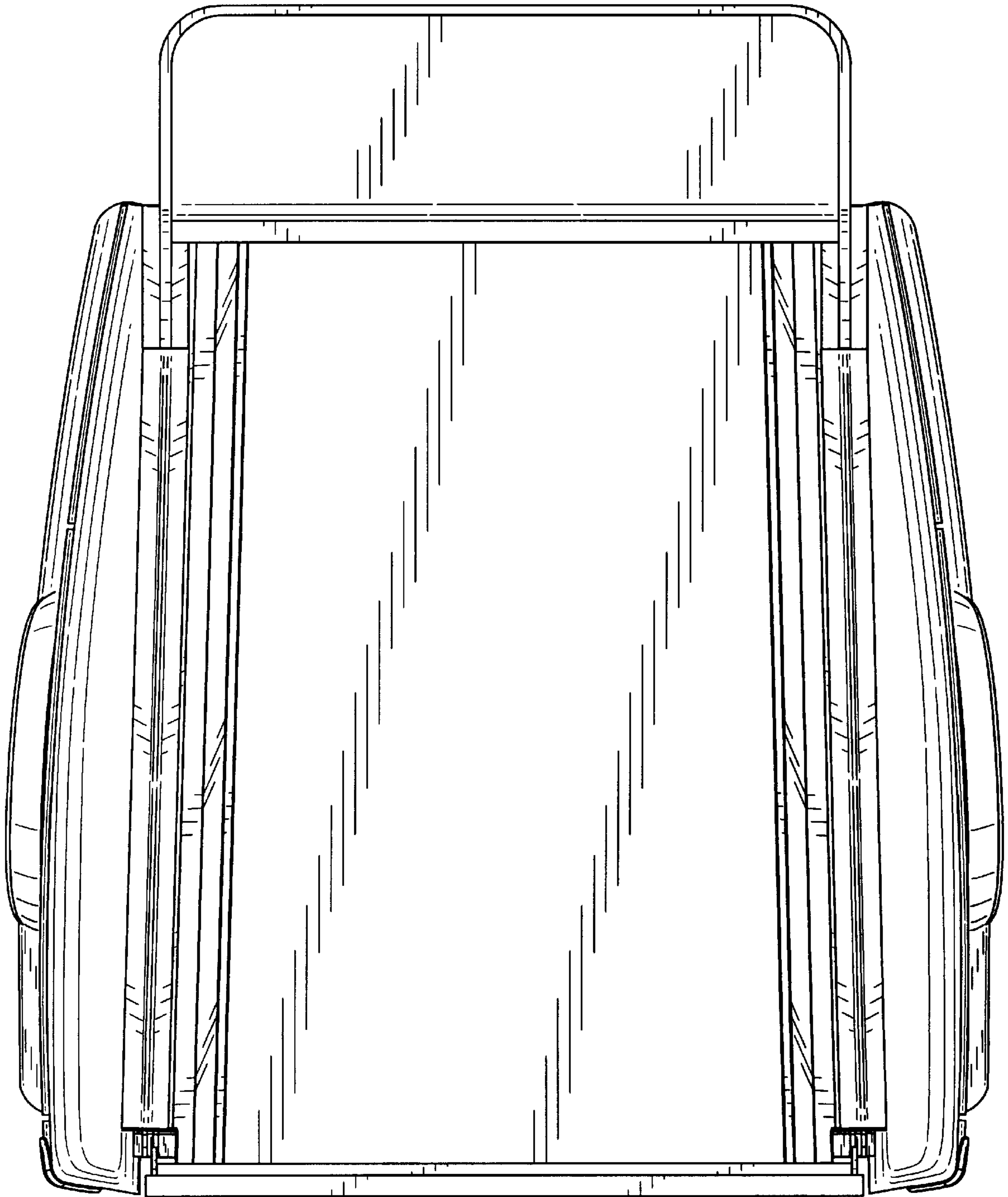

FIG. 6