



US00D414111S

United States Patent [19]
Herrmann

[11] **Patent Number: Des. 414,111**
[45] **Date of Patent: ** Sep. 21, 1999**

[54] **BOTTLE WITH CAP**
[75] Inventor: **Lutz Herrmann**, Hamburg, Germany
[73] Assignee: **The Procter & Gamble Company**,
Cincinnati, Ohio
[**] Term: **14 Years**

D. 45,248 2/1914 Whitney et al. D9/500
D. 84,683 7/1931 Davis D9/503
D. 209,480 12/1967 Wallace D9/500
D. 256,776 9/1980 Monnet D9/503
D. 406,066 2/1999 Crawford D9/557

Primary Examiner—Dominic Simone
Attorney, Agent, or Firm—Jack L. Oney, Jr.

[21] Appl. No.: **29/084,571**
[22] Filed: **Mar. 5, 1998**

[57] **CLAIM**

The ornamental design for a bottle with cap, as shown and described.

[30] **Foreign Application Priority Data**

Sep. 9, 1997 [GB] United Kingdom 2068938

DESCRIPTION

[51] **LOC (6) Cl.** **09-01**
[52] **U.S. Cl.** **D9/503**
[58] **Field of Search** D9/500, 503, 545,
D9/557, 435, 455; 215/381, 383, 384

FIG. 1 is a side elevational view of a bottle with cap embodying our new design, with the other side elevational view thereof being the same;
FIG. 2 is a perspective view thereof;
FIG. 3 is a bottom view thereof; and,
FIG. 4 is a top view thereof.

[56] **References Cited**

U.S. PATENT DOCUMENTS

D. 39,921 4/1909 Boldt D9/500

1 Claim, 1 Drawing Sheet

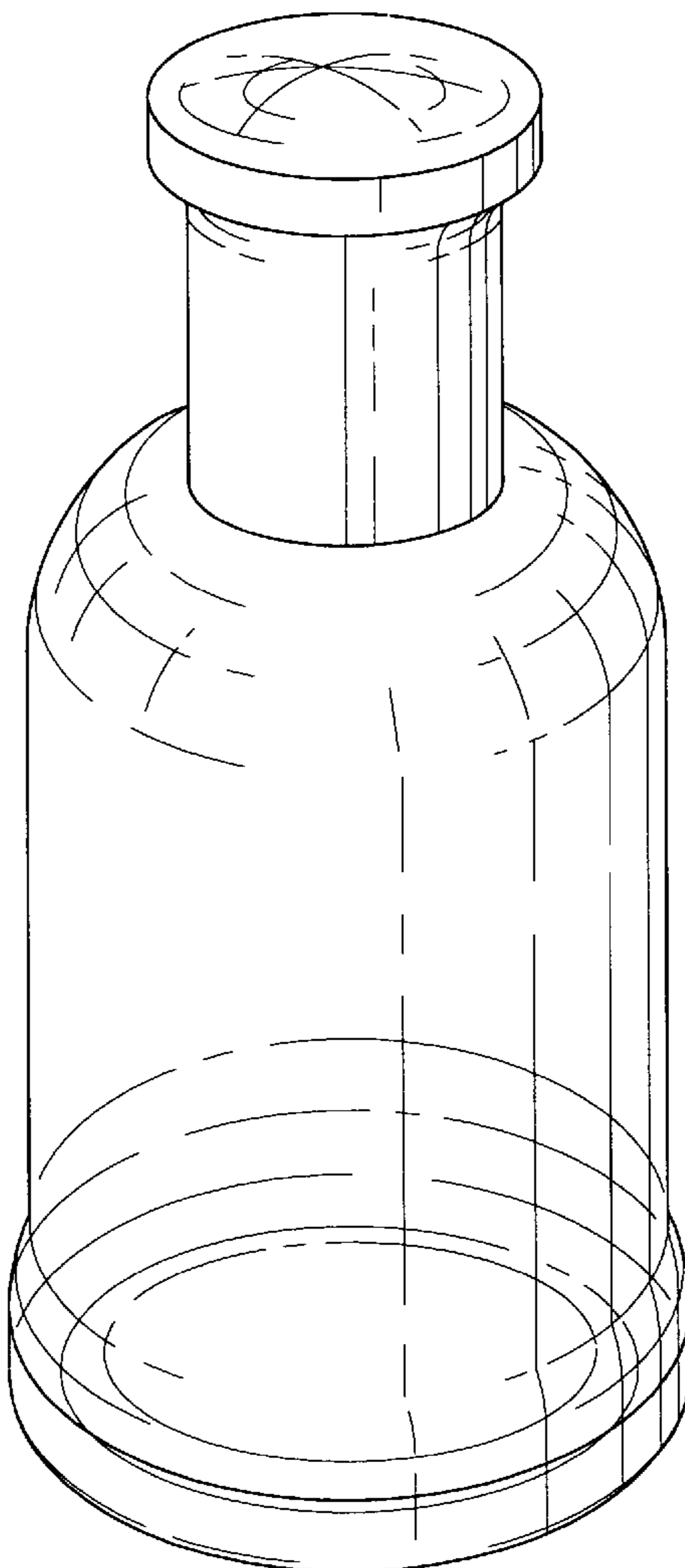

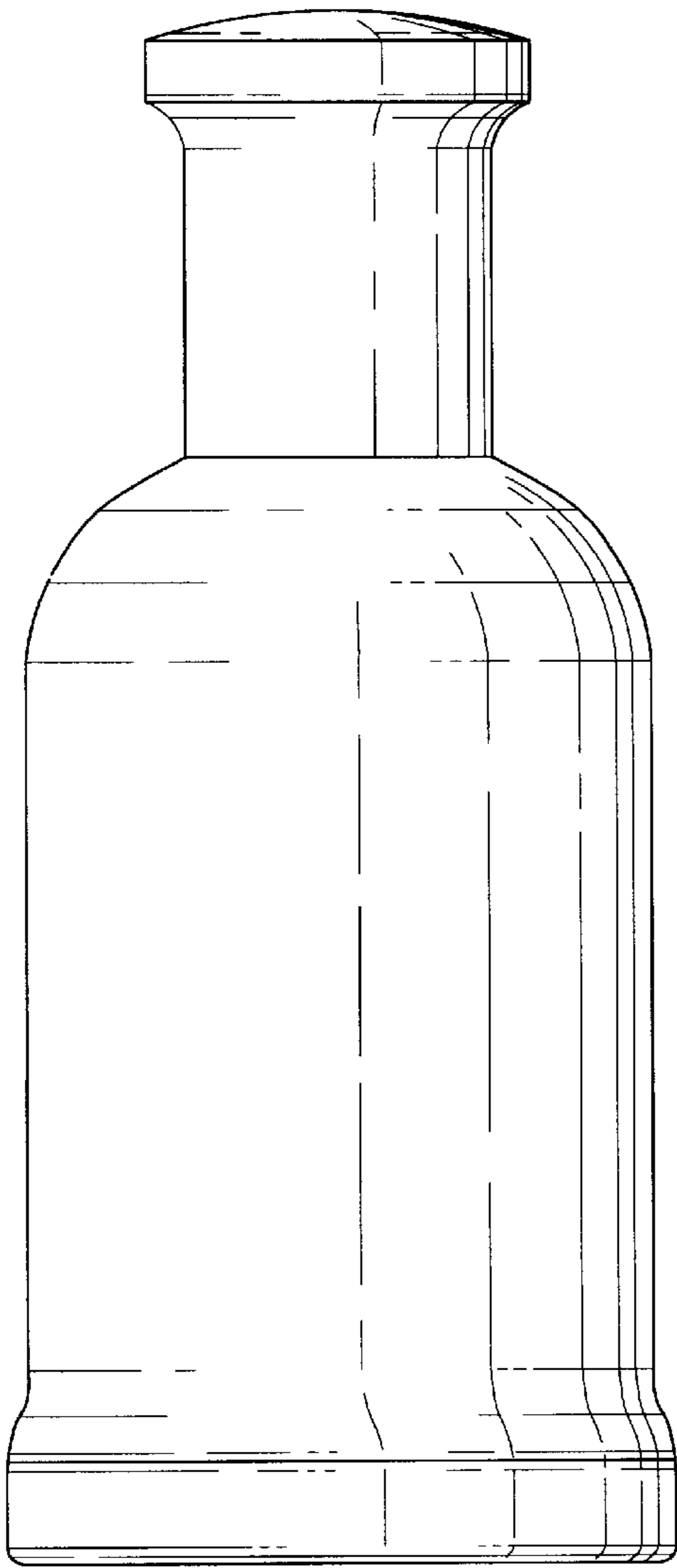

FIG. 1

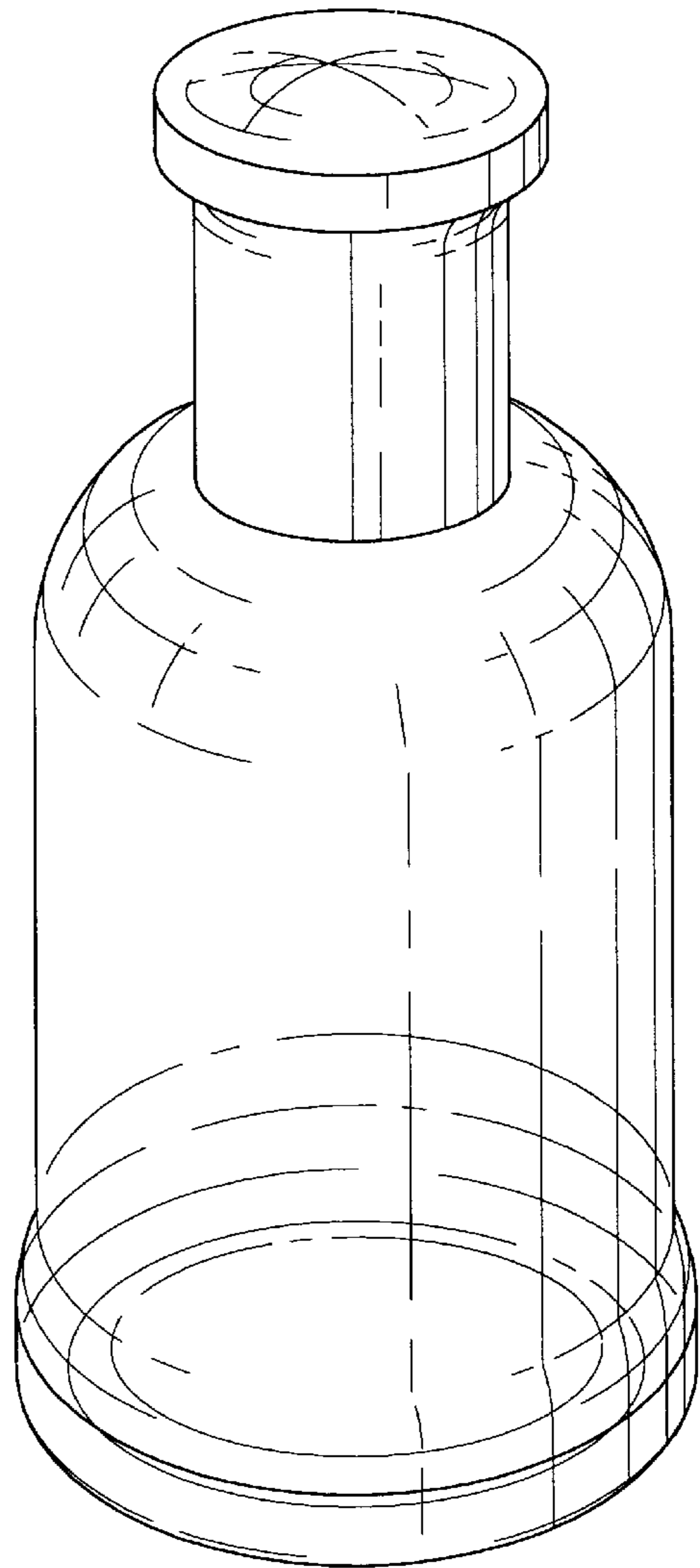

FIG. 2

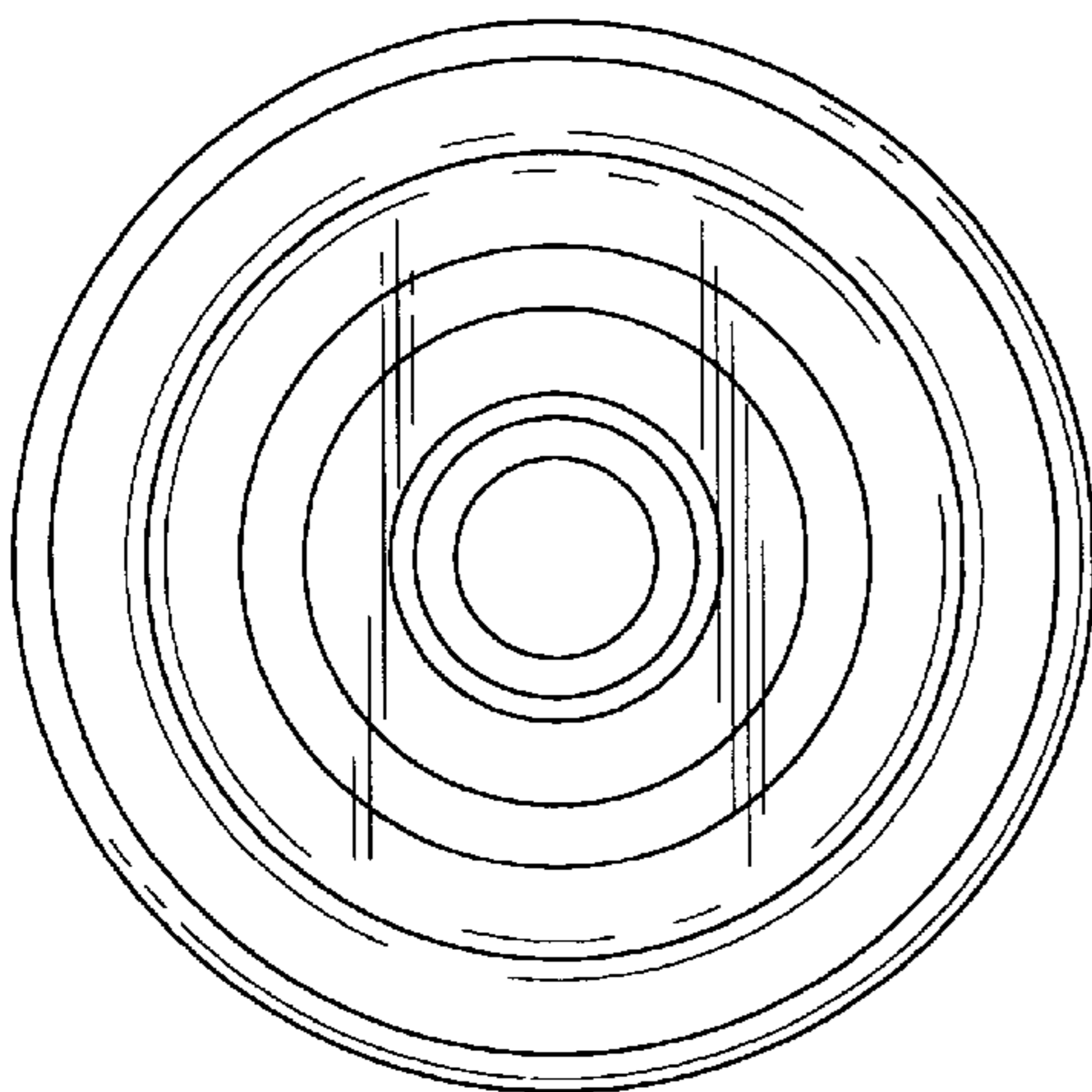

FIG. 3

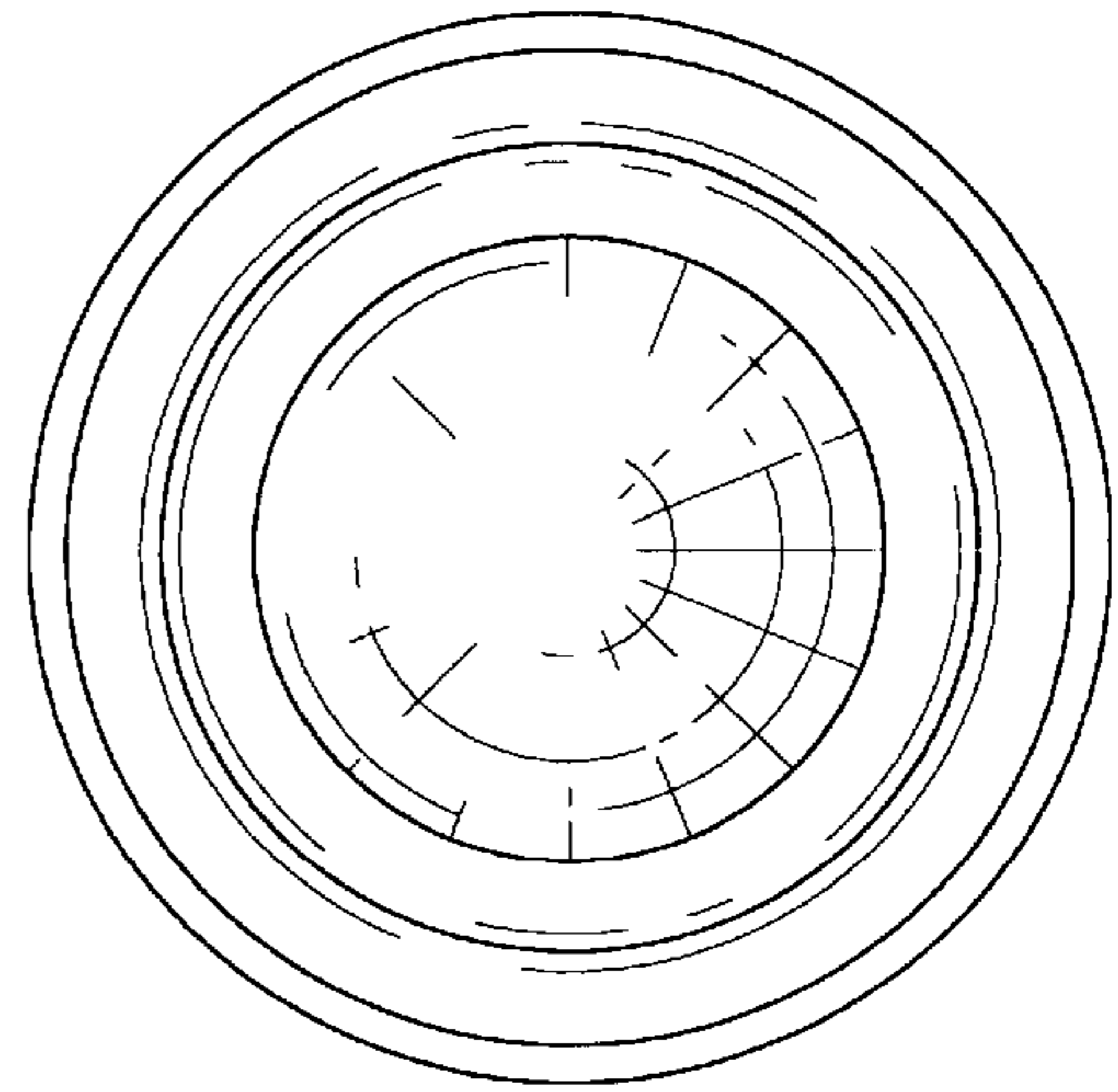

FIG. 4