



US00D414054S

**United States Patent** [19]  
**Hurd**

[11] **Patent Number: Des. 414,054**

[45] **Date of Patent: \*\* Sep. 21, 1999**

[54] **SMALL MOBILE BOOKCASE WITH OPPOSING SHELVES AND STORAGE BOX**

D. 329,251 9/1992 Olswold et al. .  
1,760,854 5/1930 Wright ..... 280/47.35  
5,343,816 9/1994 Sideris .

[76] Inventor: **Harry Hurd**, 309 Moss Run, Raleigh, N.C. 27614

*Primary Examiner*—Doris V. Coles  
*Assistant Examiner*—Linda Brooks

[\*\*] Term: **14 Years**

[57] **CLAIM**

[21] Appl. No.: **29/083,249**

The ornamental design for a small mobile bookcase with opposing shelves and storage box, as shown and described.

[22] Filed: **Feb. 5, 1998**

**DESCRIPTION**

[51] **LOC (6) Cl.** ..... **06-04**

[52] **U.S. Cl.** ..... **D6/436**

[58] **Field of Search** ..... D6/430, 432, 436-439, D6/477-479; D34/12, 17, 19-21; 211/85.8; 312/249.8, 249.11-249.13; 280/47.19, 47.35, 79.3; 180/16, 59, 60, 91, 149

FIG. 1 is a top, front, and left side perspective view of the small mobile bookcase with opposing shelves and storage box;

FIG. 2 is a bottom, rear, and right side perspective view of the small mobile bookcase with opposing shelves and storage box;

FIG. 3 is an enlarged front elevational view of the small mobile bookcase with opposing shelves and storage box;

FIG. 4 is a top view of the small mobile bookcase with opposing shelves and storage box of FIG. 3; and,

FIG. 5 is a back elevational view of the small mobile bookcase with opposing shelves and storage box of FIG. 3.

[56] **References Cited**

**U.S. PATENT DOCUMENTS**

- D. 117,446 11/1939 Butzner .
- D. 189,816 2/1961 Rhoads ..... D34/20
- D. 239,474 4/1976 Underwood et al. .
- D. 315,995 4/1991 Miller ..... D6/436
- D. 322,184 12/1991 Prevedello et al. .... D6/436

**1 Claim, 1 Drawing Sheet**

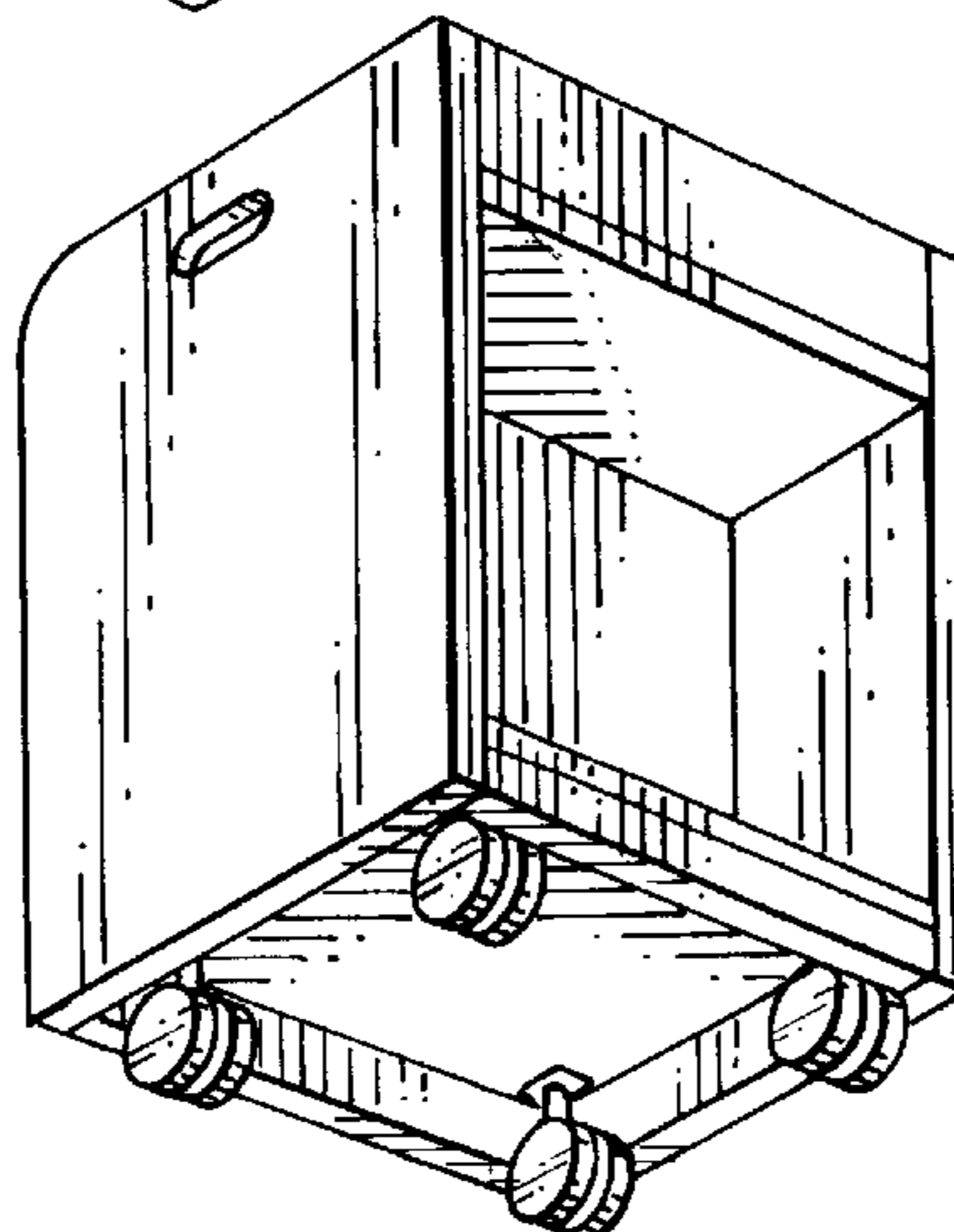
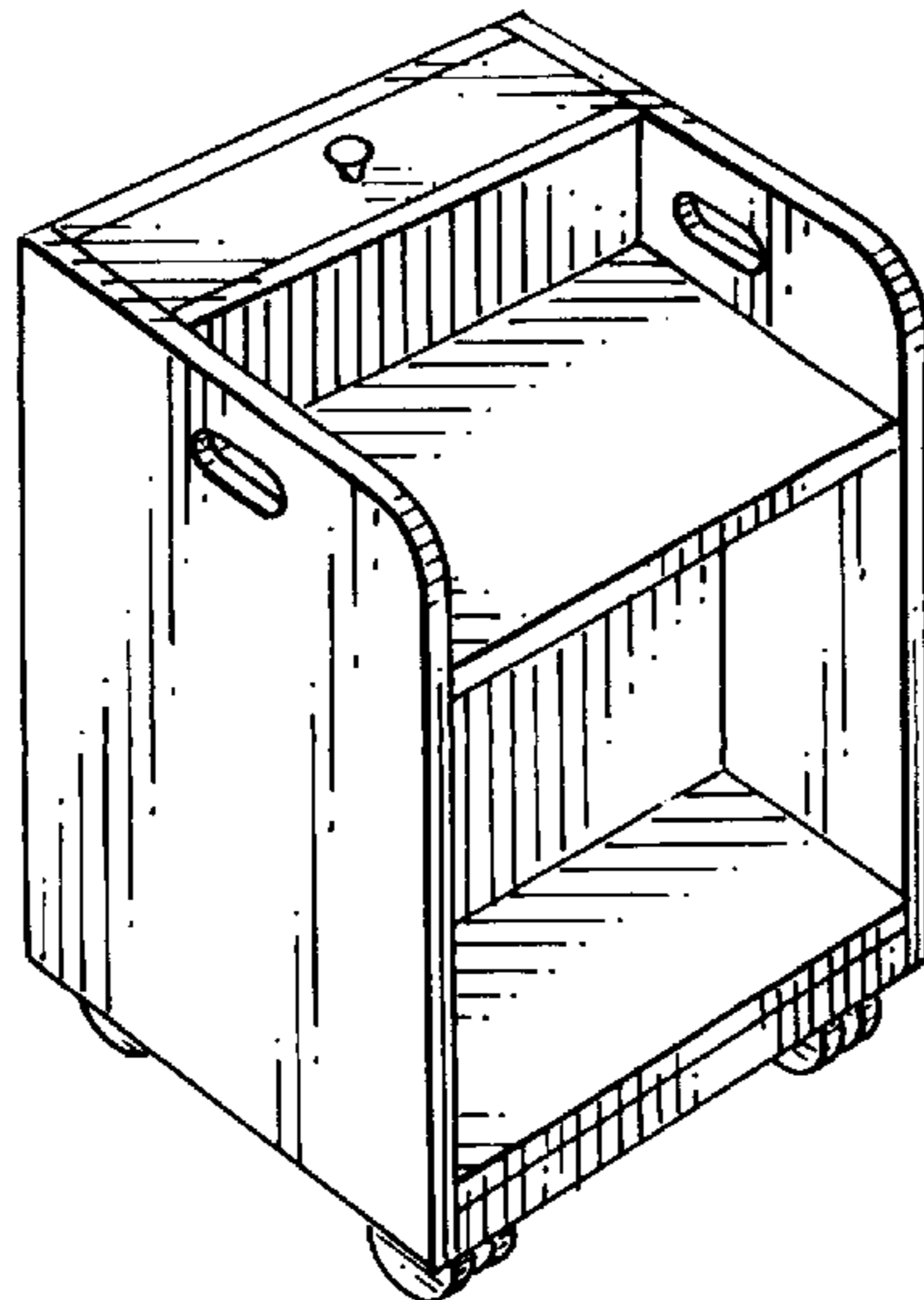

FIG. 1

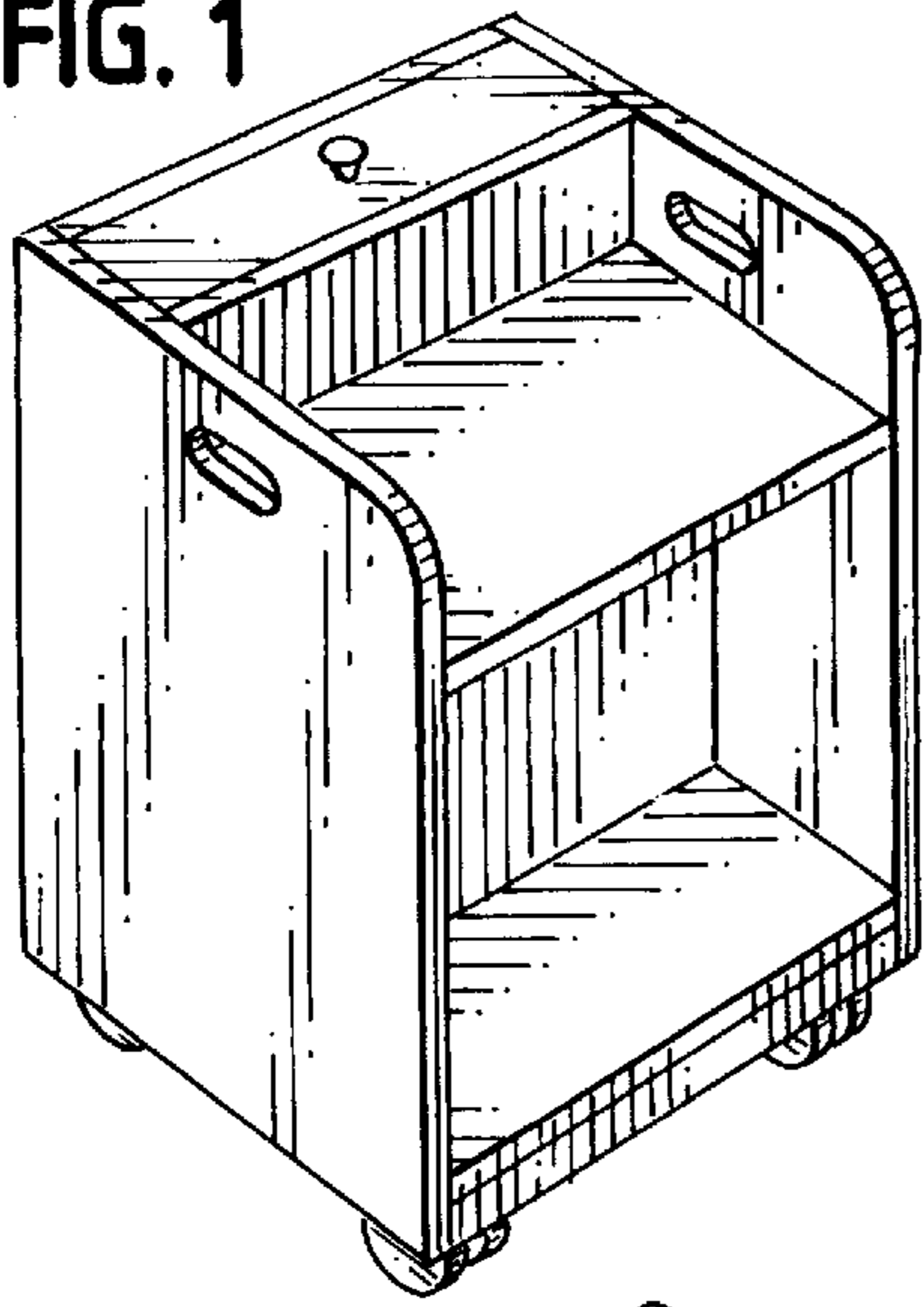

FIG. 2

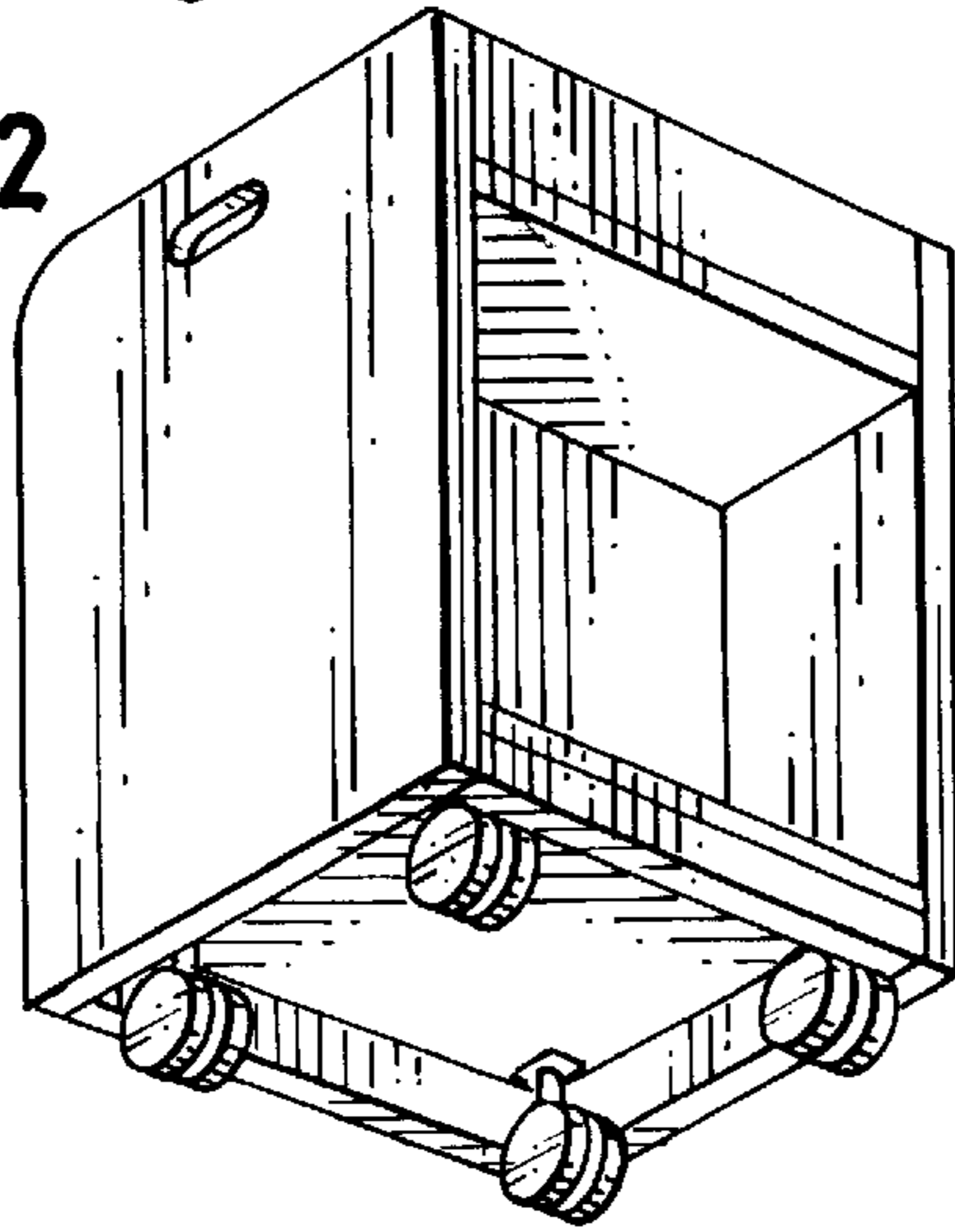

FIG. 4

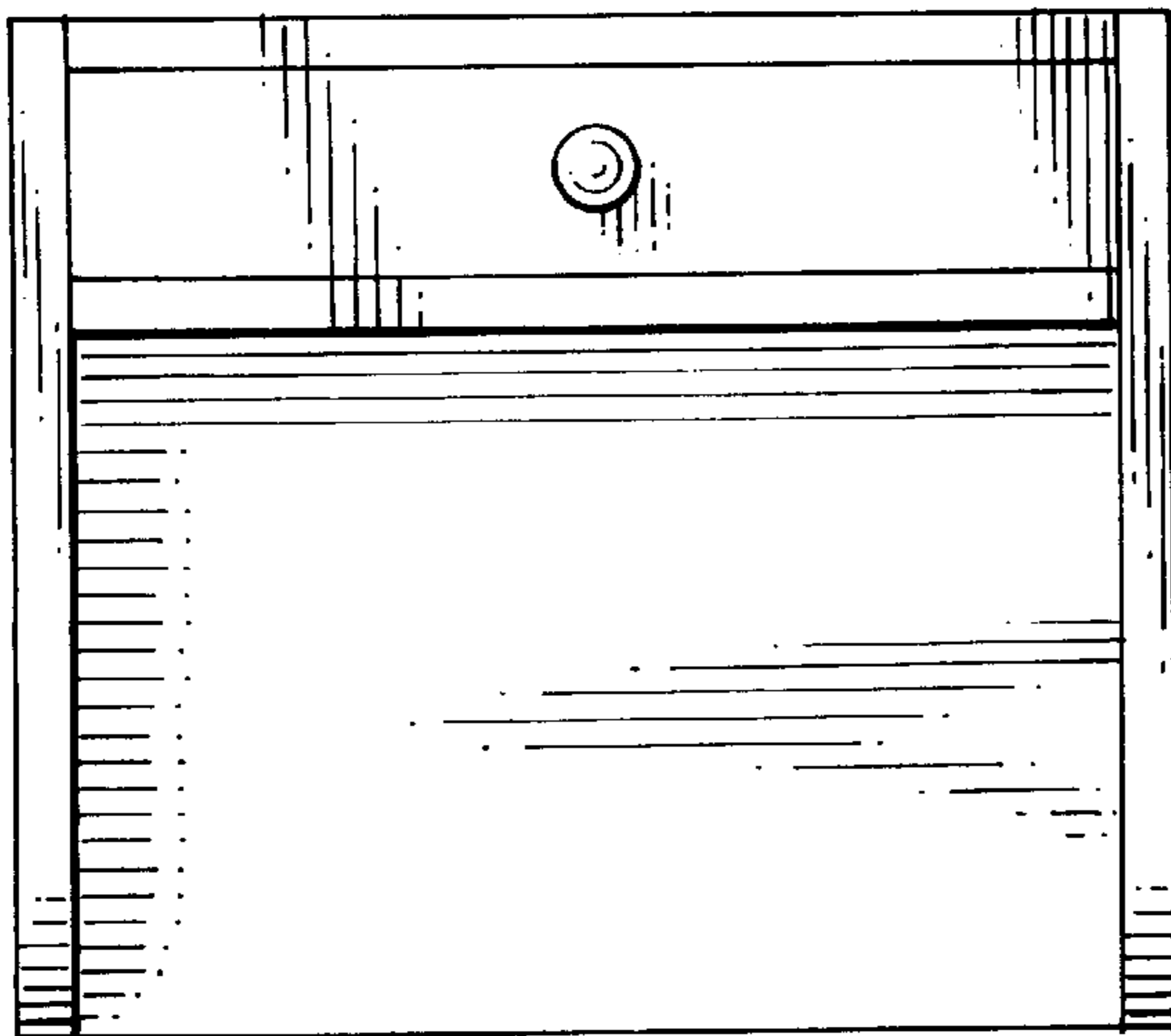

FIG. 3

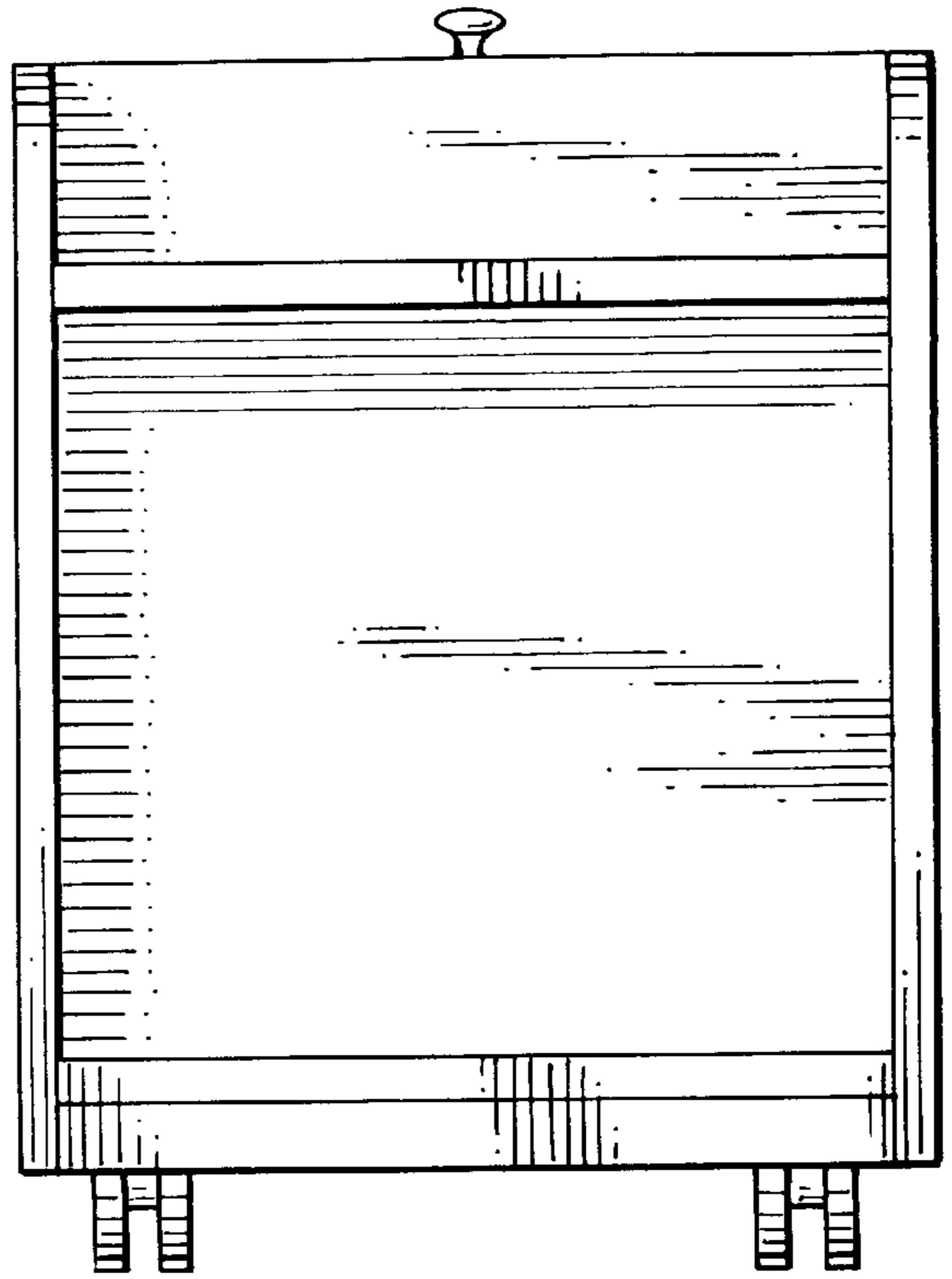

FIG. 5

