



US00D414008S

United States Patent [19] Jackson

[11] Patent Number: Des. 414,008

[45] Date of Patent: ** Sep. 14, 1999

[54] SAND BAG HOLDER

[76] Inventor: Fred L. Jackson, P.O. Box 114, Lytle Creek, Calif. 92358

[**] Term: 14 Years

[21] Appl. No.: 29/099,379

[22] Filed: Jan. 20, 1999

[51] LOC (6) Cl. 09-09

[52] U.S. Cl. D34/6; D34/1

[58] Field of Search D34/1, 2, 5, 6, D34/10; 248/95, 97, 100; 220/908, 909

5,323,990 6/1994 Graves 248/97

5,597,145 1/1997 Meyers et al. 248/97

5,738,314 4/1998 Davis 248/97

5,868,364 2/1999 Macmillan 248/97

Primary Examiner—Susan J. Lucas
 Assistant Examiner—Cynthia Ramirez
 Attorney, Agent, or Firm—Goldstein & Canino

[56] **References Cited**
 U.S. PATENT DOCUMENTS

645,199	3/1900	Brooks	248/95
742,578	10/1903	Brown	248/95
1,414,575	5/1922	McCart	248/97
2,172,529	9/1939	Barker	248/97
2,783,010	2/1957	Ferguson	248/94
4,273,167	6/1981	Stillwell	248/97 X
4,570,423	2/1986	DeLong	248/97 X
4,832,292	5/1989	Backham	248/95
4,948,075	8/1990	Allen	248/97
5,090,756	2/1992	Pfister	248/95 X
5,169,101	12/1992	Wenzel et al.	248/97

[57] **CLAIM**
 The ornamental design for a sand bag holder, as shown and described.

DESCRIPTION

FIG. 1 is a diagrammatic perspective view of the sand bag holder in full lines with a sand bag shown in broken lines representing environmental association matter being for illustrative purposes only and forming no part of the claimed invention;

FIG. 2 is a front elevational view of the sand bag holder, the rear elevational view being a mirror image of the front view thereof.

FIG. 3 is a right side elevational view thereof, the left side elevational view being a mirror image of the right side view.

FIG. 4 is a top plan view of the sand bag holder; and, FIG. 5 is a bottom plan view thereof.

1 Claim, 5 Drawing Sheets

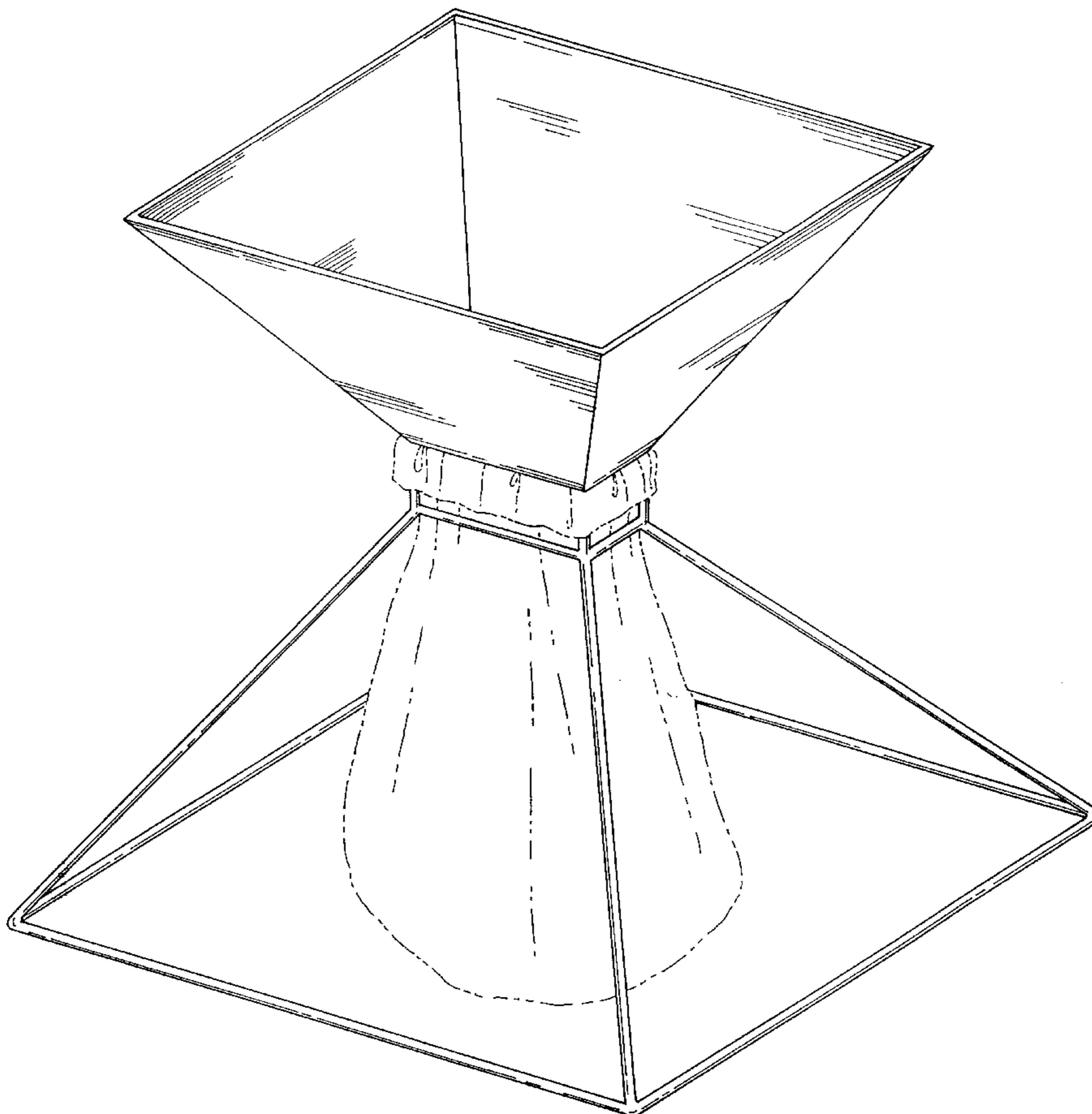

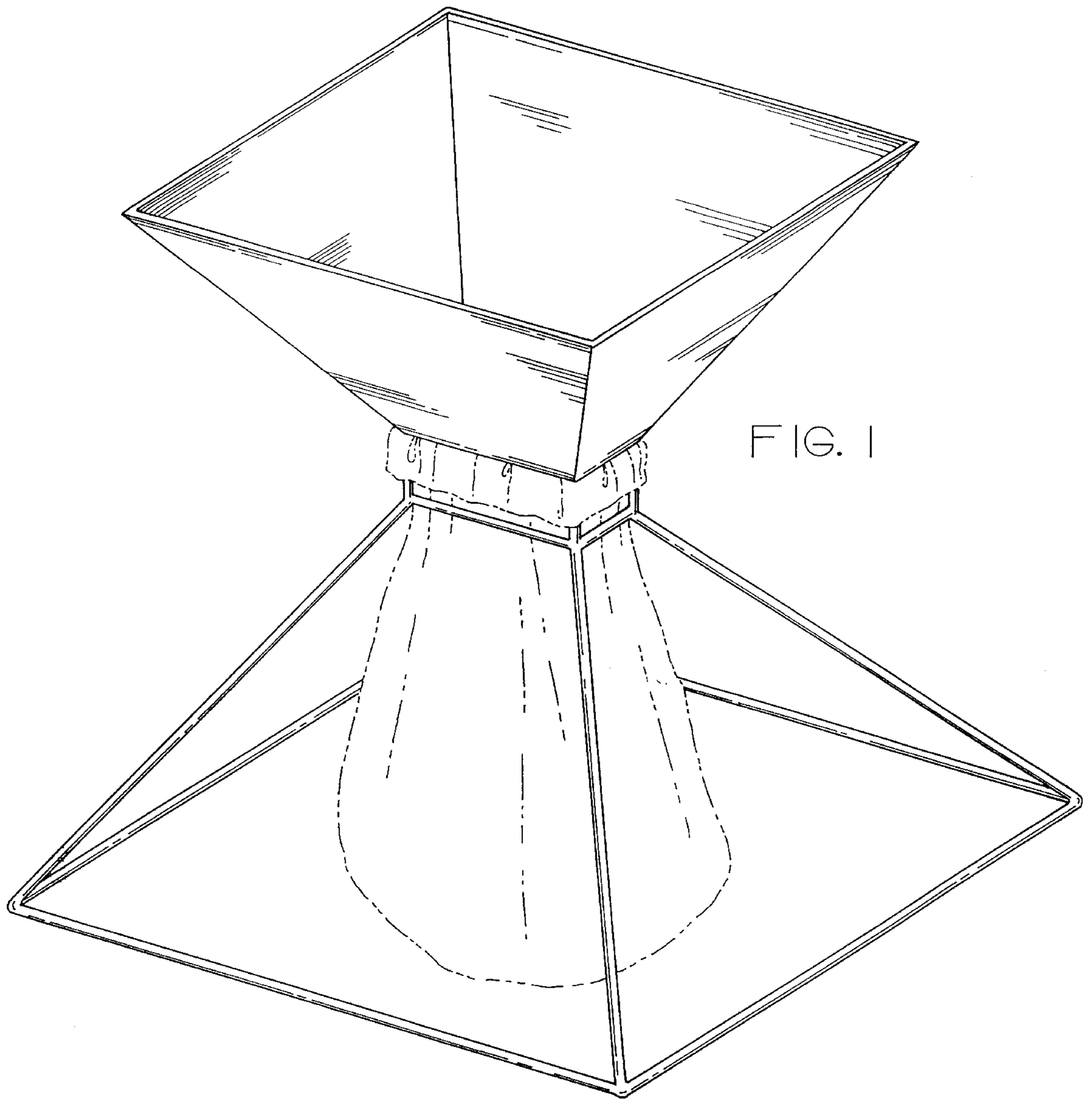

FIG. 2

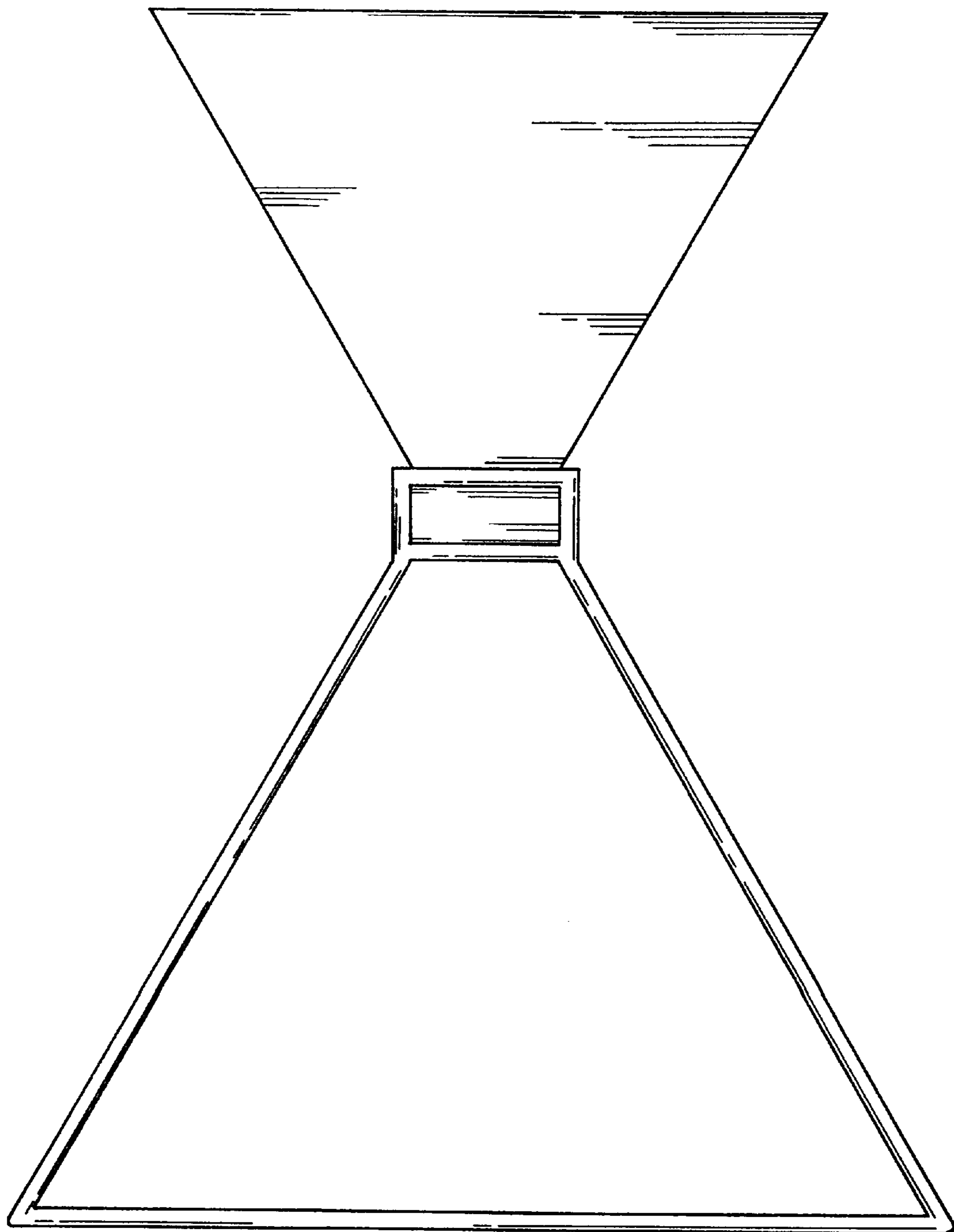

FIG. 3

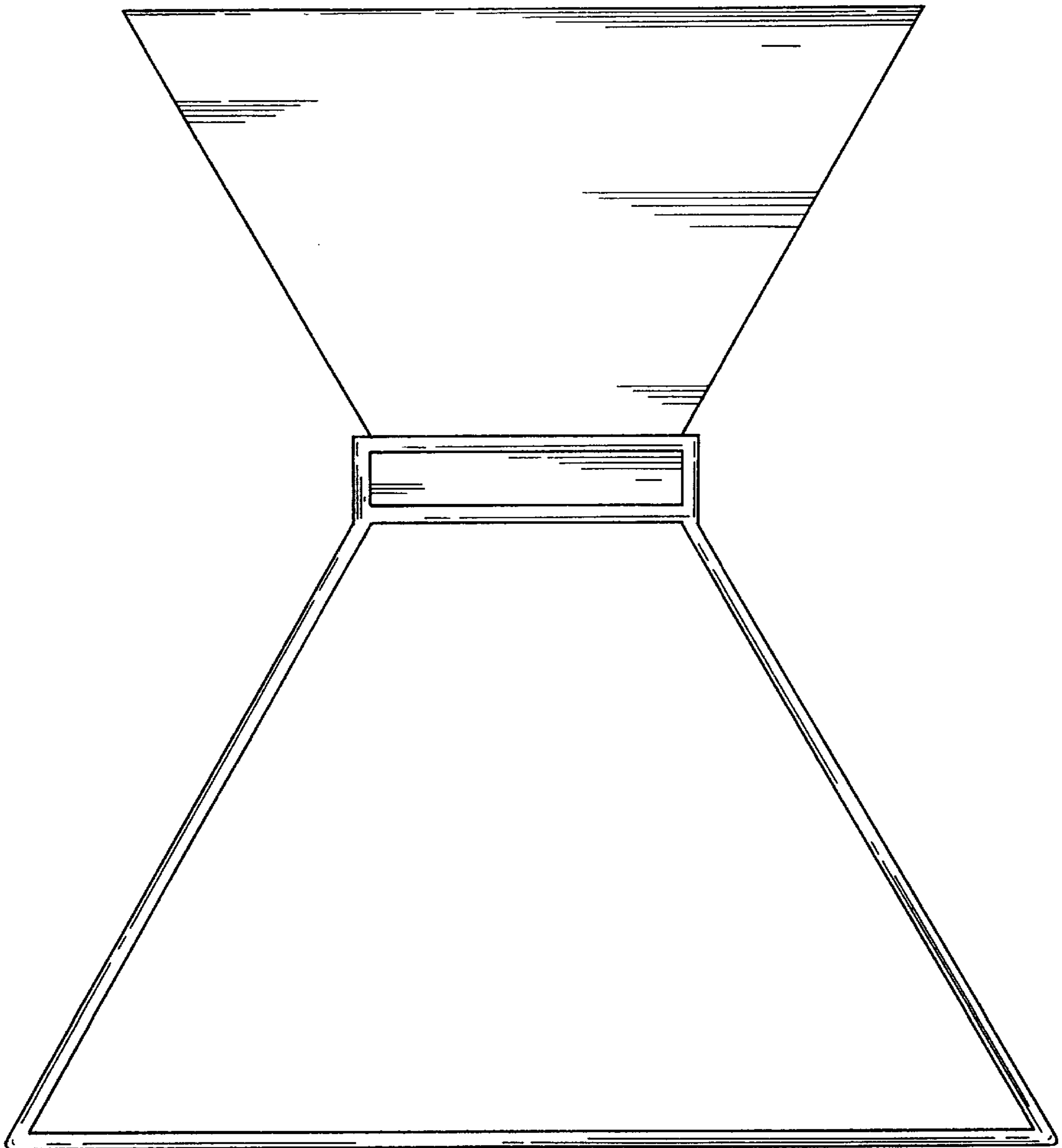

FIG. 4

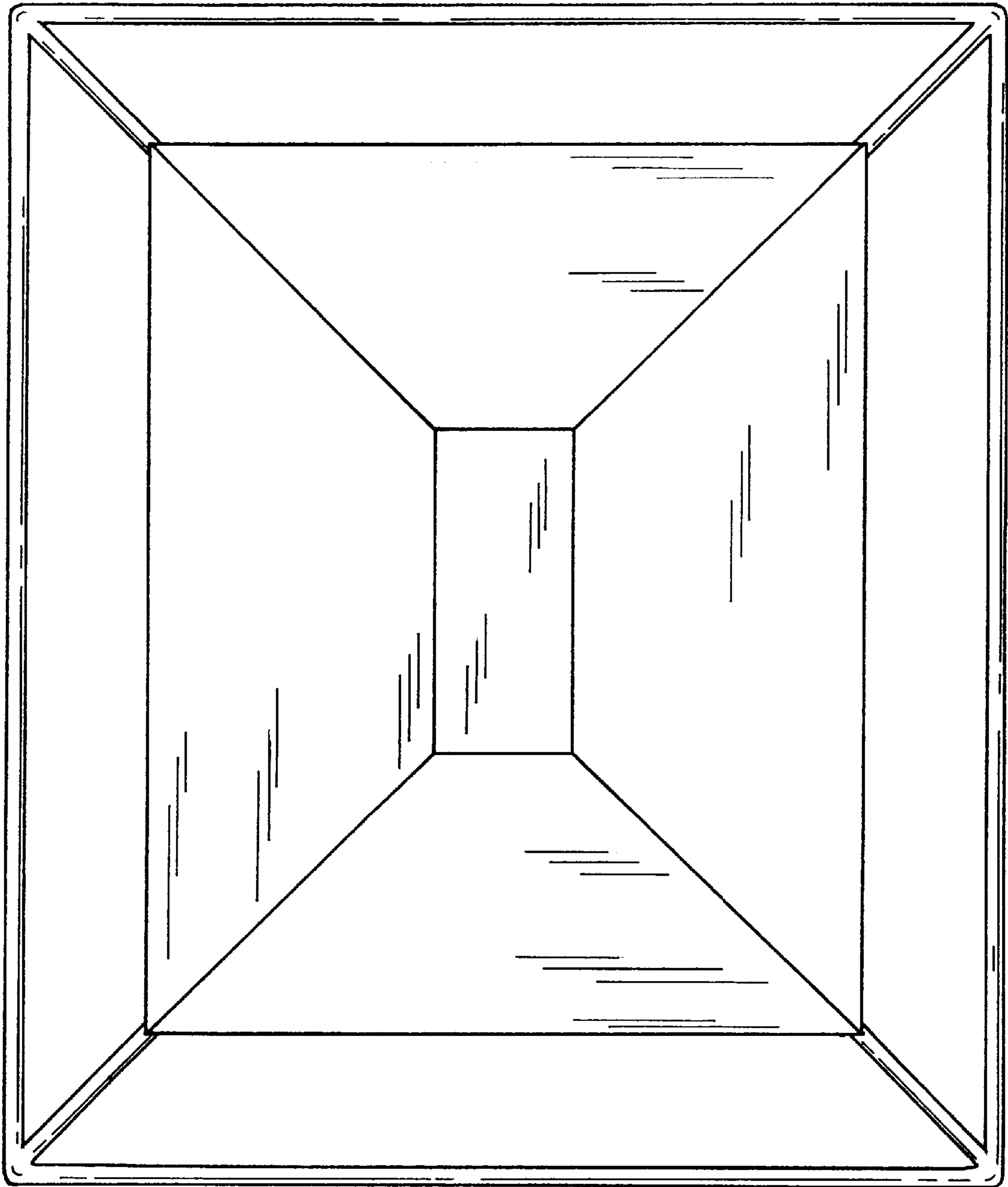

FIG. 5

