



US00D413847S

United States Patent [19]

Hartmann et al.

[11] **Patent Number: Des. 413,847**

[45] **Date of Patent: ** *Sep. 14, 1999**

[54] **SLIMLINE LICENSE PLATE FRAME**

[75] Inventors: **Jerome J. Hartmann**, Carlisle;
Thomas R. Steinhagen, West Des Moines, both of Iowa

[73] Assignee: **Cobbs Manufacturing Company**, Des Moines, Iowa

[*] Notice: This patent is subject to a terminal disclaimer.

[**] Term: **14 Years**

[21] Appl. No.: **29/078,592**

[22] Filed: **Oct. 28, 1997**

[51] **LOC (6) Cl.** **12-16**

[52] **U.S. Cl.** **D12/193**

[58] **Field of Search** D12/193, 400;
D6/300, 303-306, 310-314; 40/200, 207,
208, 209, 210, 591; 224/522, 524, 527;
280/727, 769

[56] **References Cited**

U.S. PATENT DOCUMENTS

D. 271,011 10/1983 Bott D12/193

1,201,786 10/1916 Willwerscheid 40/209
2,012,346 8/1935 Meehan 40/209
2,211,923 8/1940 Dittmar 40/200
2,921,395 1/1960 Fishman 40/200

Primary Examiner—Robert M. Spear

[57] **CLAIM**

The ornamental design for a slimline license plate frame, as shown and described.

DESCRIPTION

FIG. 1 is a front elevational view of the slimline license plate frame.

FIG. 2 is a top view thereof, the bottom view being a mirror image.

FIG. 3 is a left end view thereof, the right end view being a mirror image.

FIG. 4 is a rear elevational view thereof; and,

FIG. 5 is a front perspective view thereof.

1 Claim, 2 Drawing Sheets

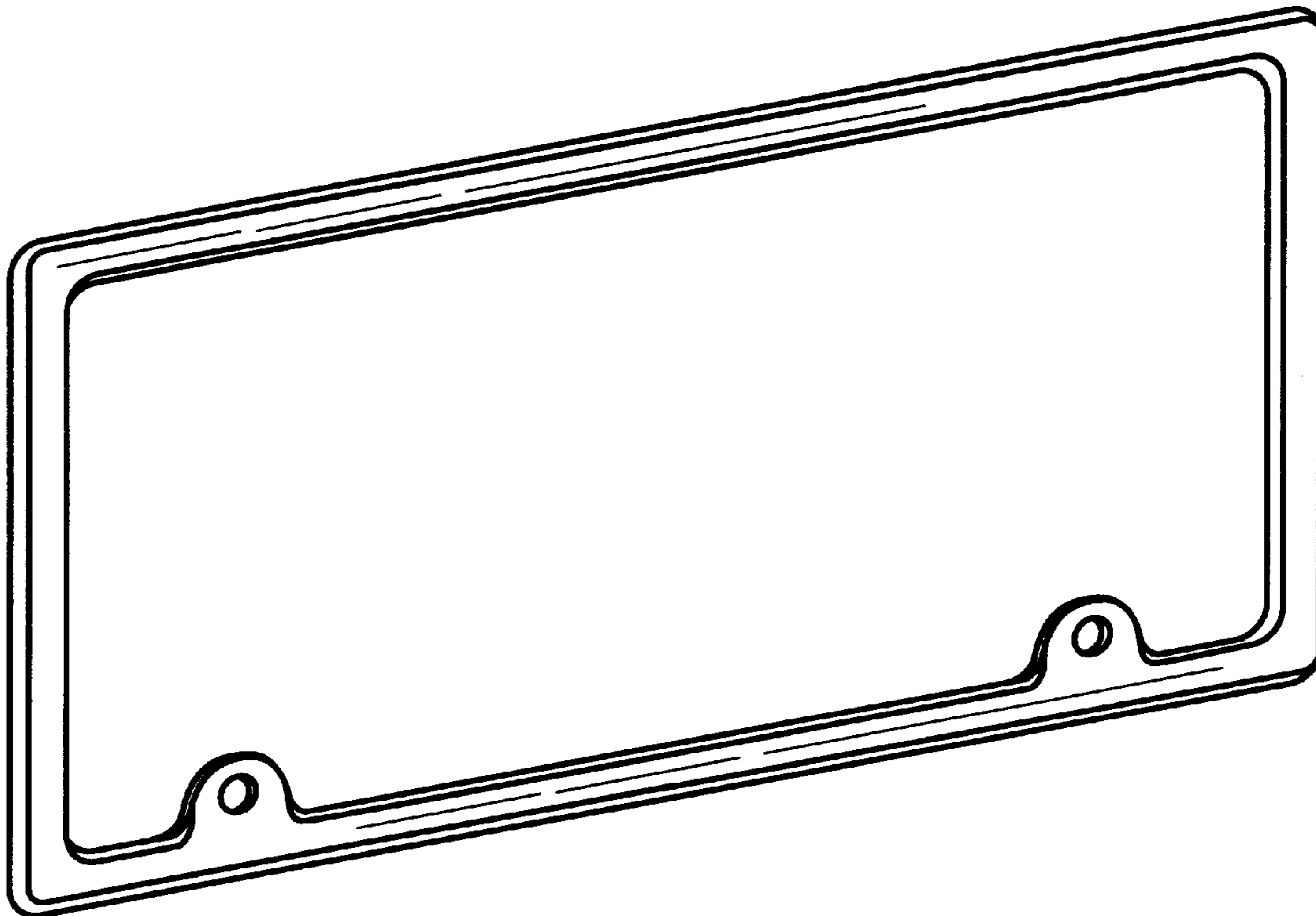

Fig 1

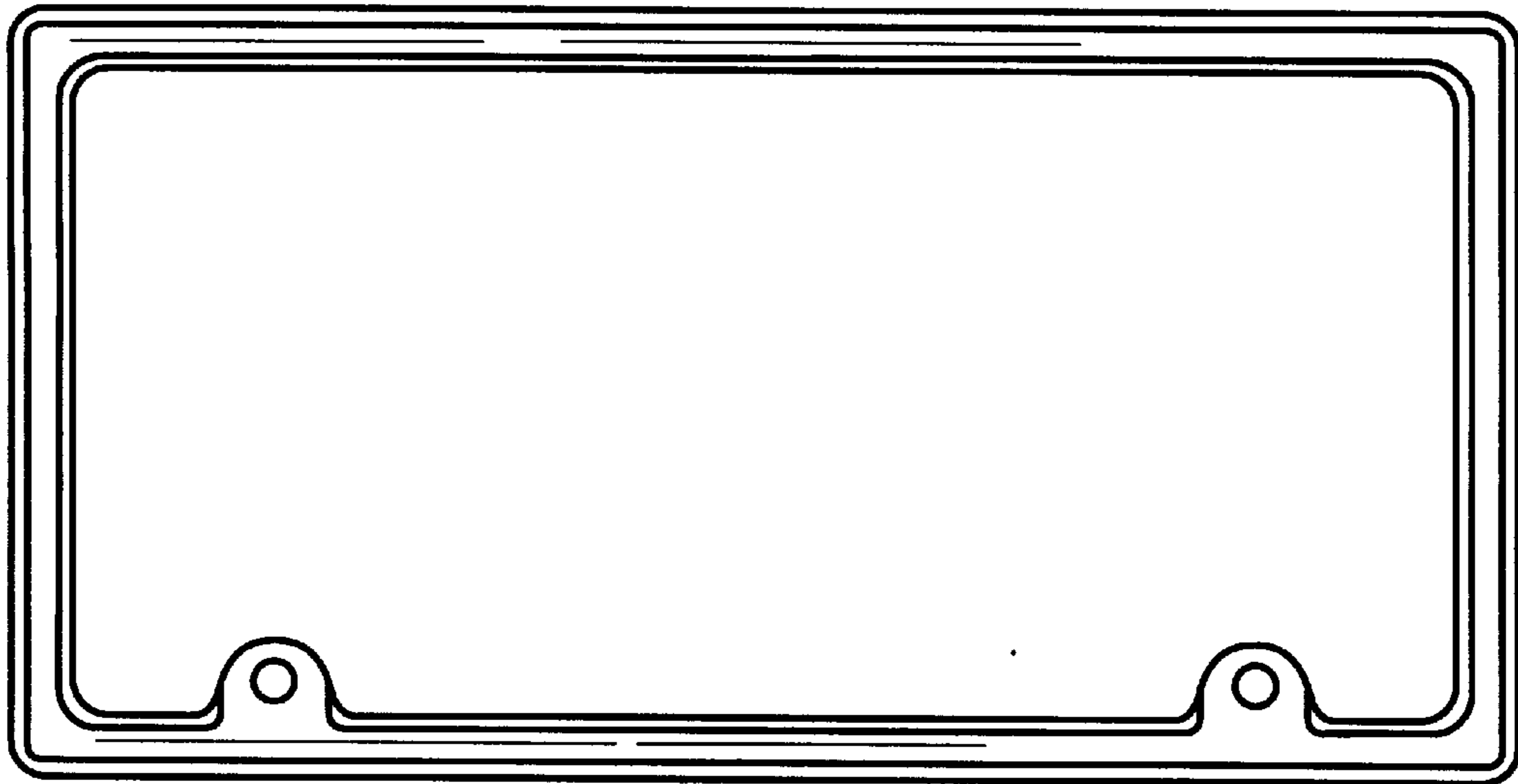

Fig 2

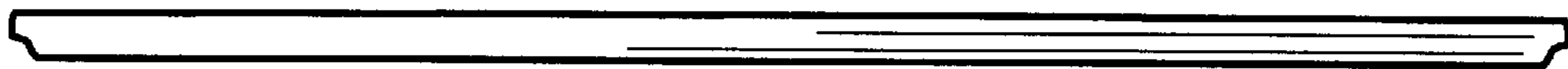

Fig 3



Fig 4

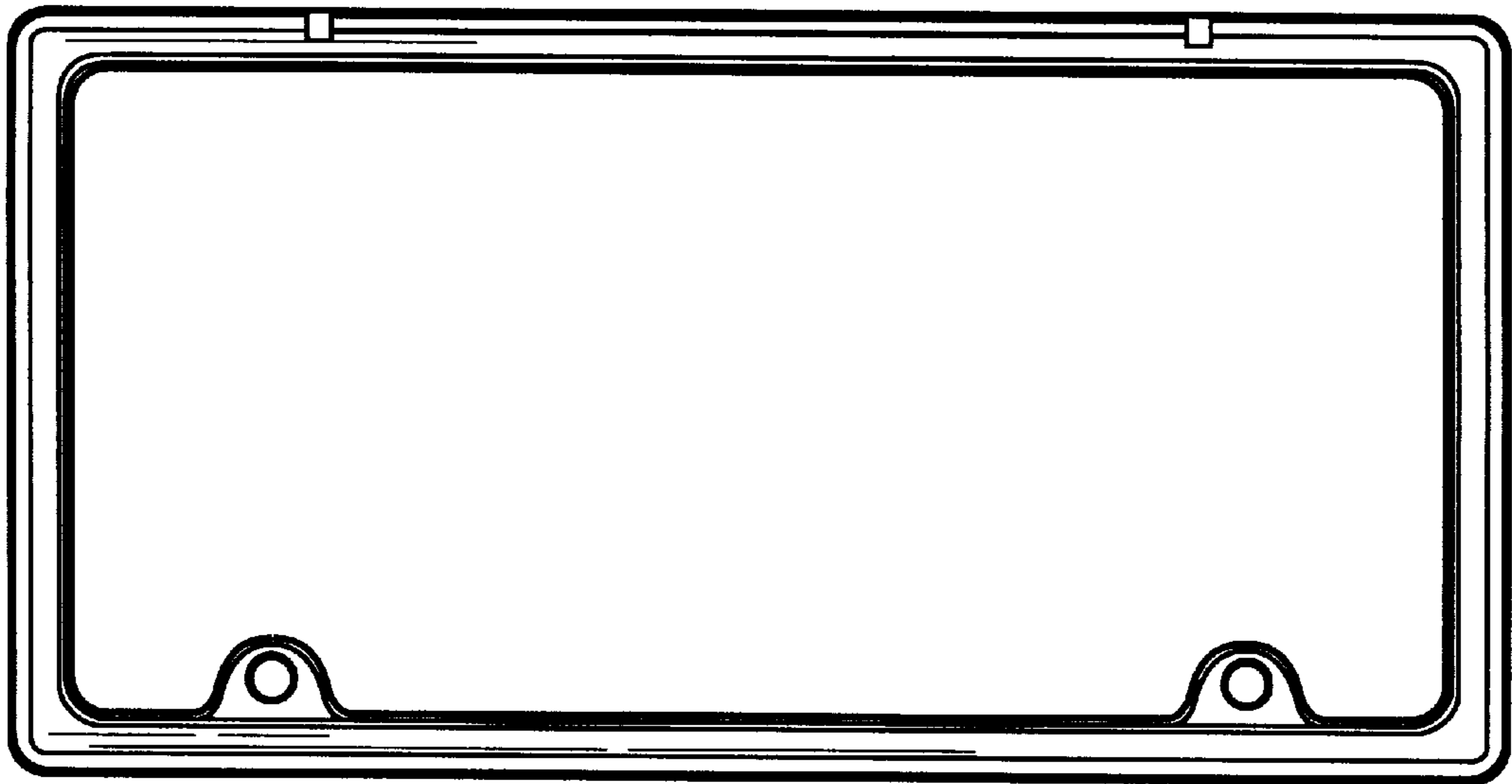

Fig 5

