



US00D413722S

United States Patent [19]

[11] Patent Number: Des. 413,722

Altenbach et al.

[45] Date of Patent: ** Sep. 14, 1999

[54] **KEY POUCH**

[76] Inventors: **Richard Altenbach; Dawn M. Simmons**, both of 19634 Valley View Dr., Topanga, Calif. 90290

[**] Term: **14 Years**

[21] Appl. No.: **29/079,121**

[22] Filed: **Nov. 10, 1997**

[51] **LOC (6) Cl.** **03-01**

[52] **U.S. Cl.** **D3/212**

[58] **Field of Search** D3/207-212; 206/37.1, 206/37.3, 37.4, 38.1, 3.7; 70/457, 456 B, 456 R; 150/900, 149; 24/116 R, 299, 3.6

[56] **References Cited**

U.S. PATENT DOCUMENTS

D. 27,911	11/1897	Hilliard	D3/212
D. 238,525	1/1976	Watts	D3/208
D. 307,979	5/1990	Purvis	D3/208
946,119	1/1910	Field	D3/212
1,110,760	9/1914	Easton	D3/212
1,365,111	1/1921	Lawrence	D3/212
5,042,649	8/1991	McNutt	D3/212

Primary Examiner—Ralf Seifert

Attorney, Agent, or Firm—Blakely Sokoloff Taylor & Zafman

[57] **CLAIM**

The ornamental design for a key pouch, as shown and described.

DESCRIPTION

FIG. 1 is a perspective view of the device installed on a steering column having a substantially square cross section of an automobile in a closed position in which the environment is shown in shadow line.

FIG. 2 is a perspective view of the device installed on the steering column of the automobile as in FIG. 1, but in an open position.

FIG. 3 is a right side elevation view with the elastic strap at rest and the pouch in a closed position.

FIG. 4 is a bottom plan view thereof.

FIG. 5 is a top plan view thereof.

FIG. 6 is a left side elevation view thereof.

FIG. 7 is a rear elevation view thereof.

FIG. 8 is a front elevation view thereof.

FIG. 9 is a right side elevation view with the elastic strap at rest and the pouch in an open position.

FIG. 10 is a left side elevation view with the elastic strap at rest and the pouch in an open position; and,

FIG. 11 is a perspective view of a key pouch showing a second embodiment of my new design.

The broken line showing of a steering column and associated elements, in FIGS. 1 and 2, is for illustrative purposes only and forms no part of the claimed design.

1 Claim, 5 Drawing Sheets

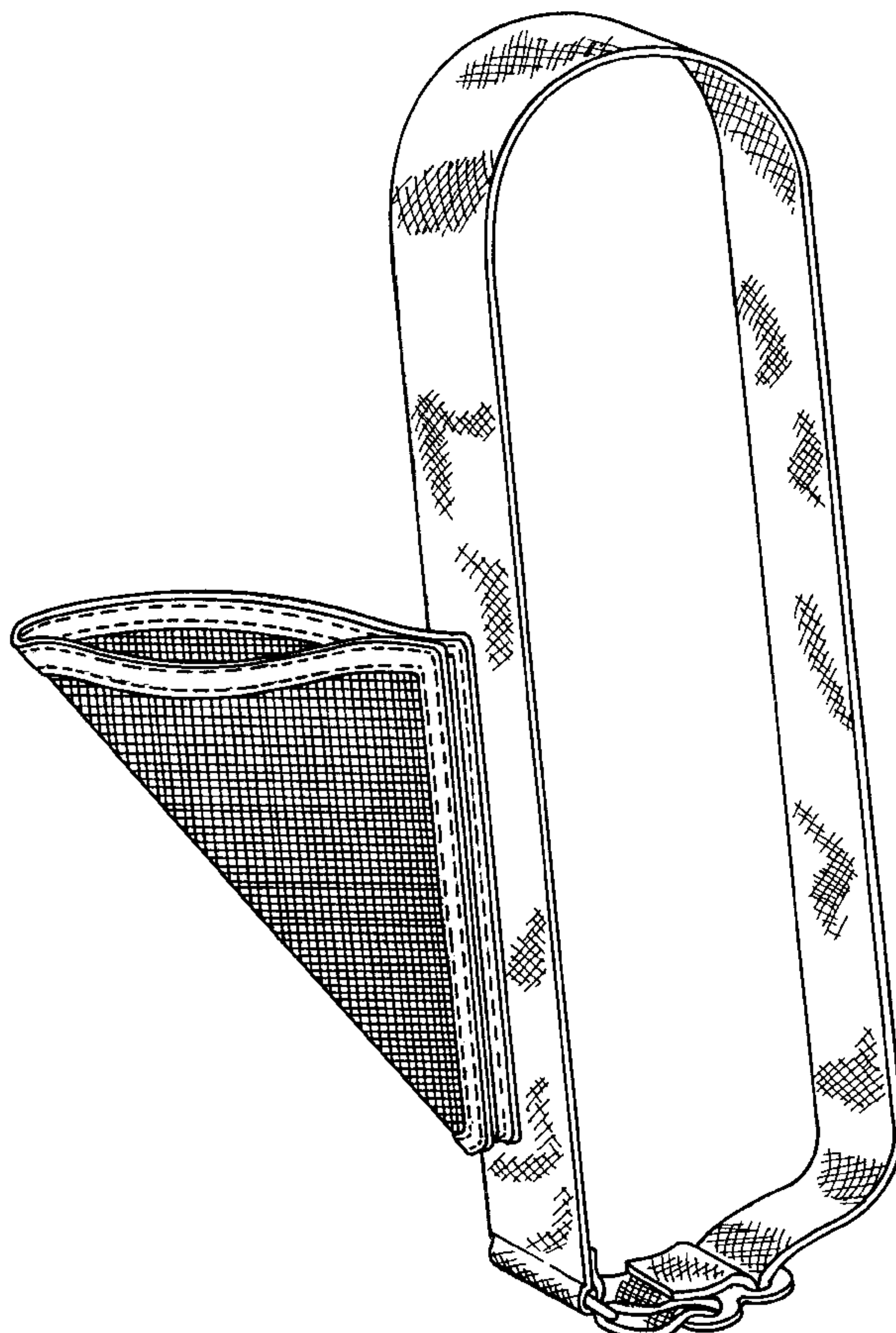

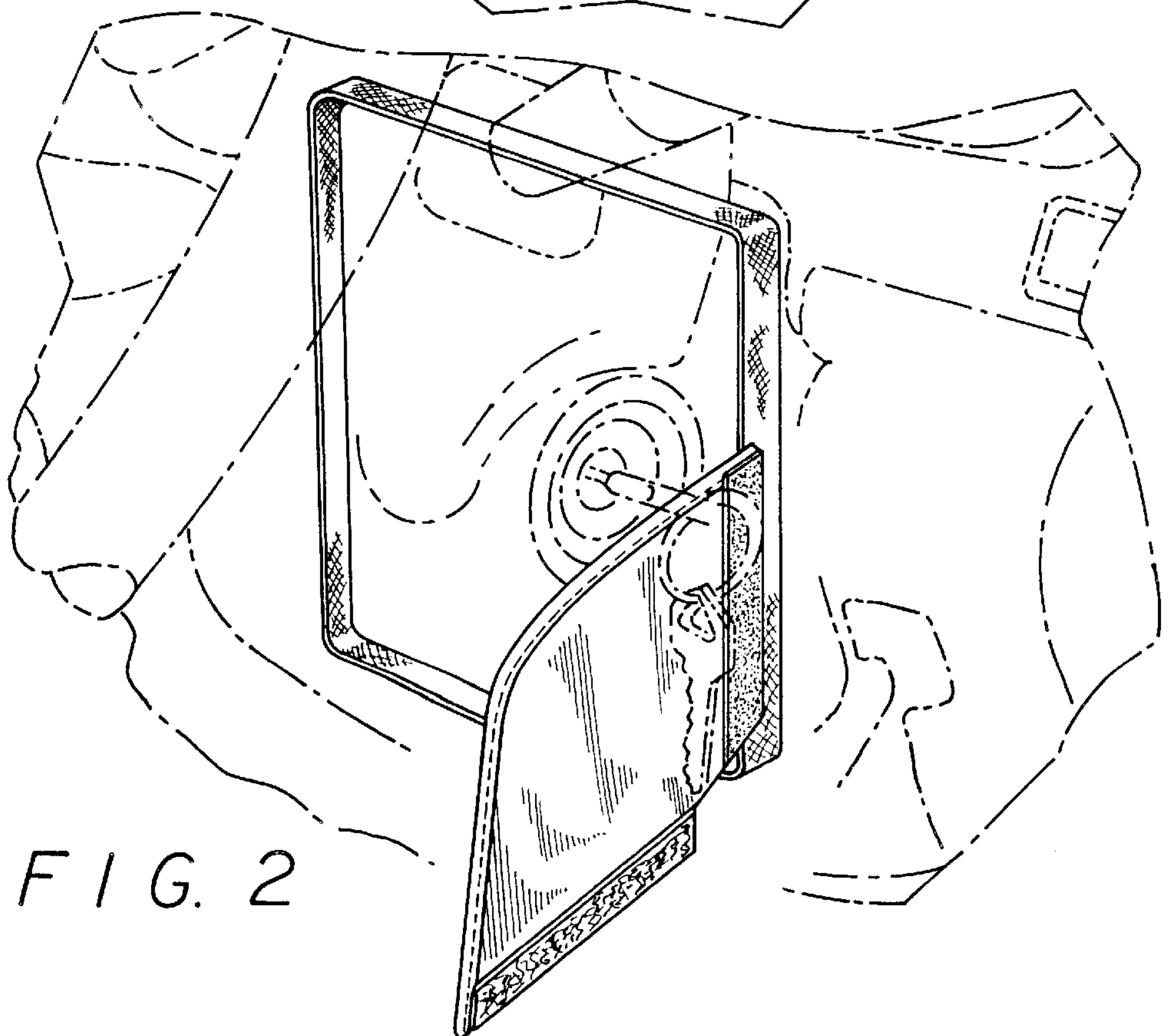
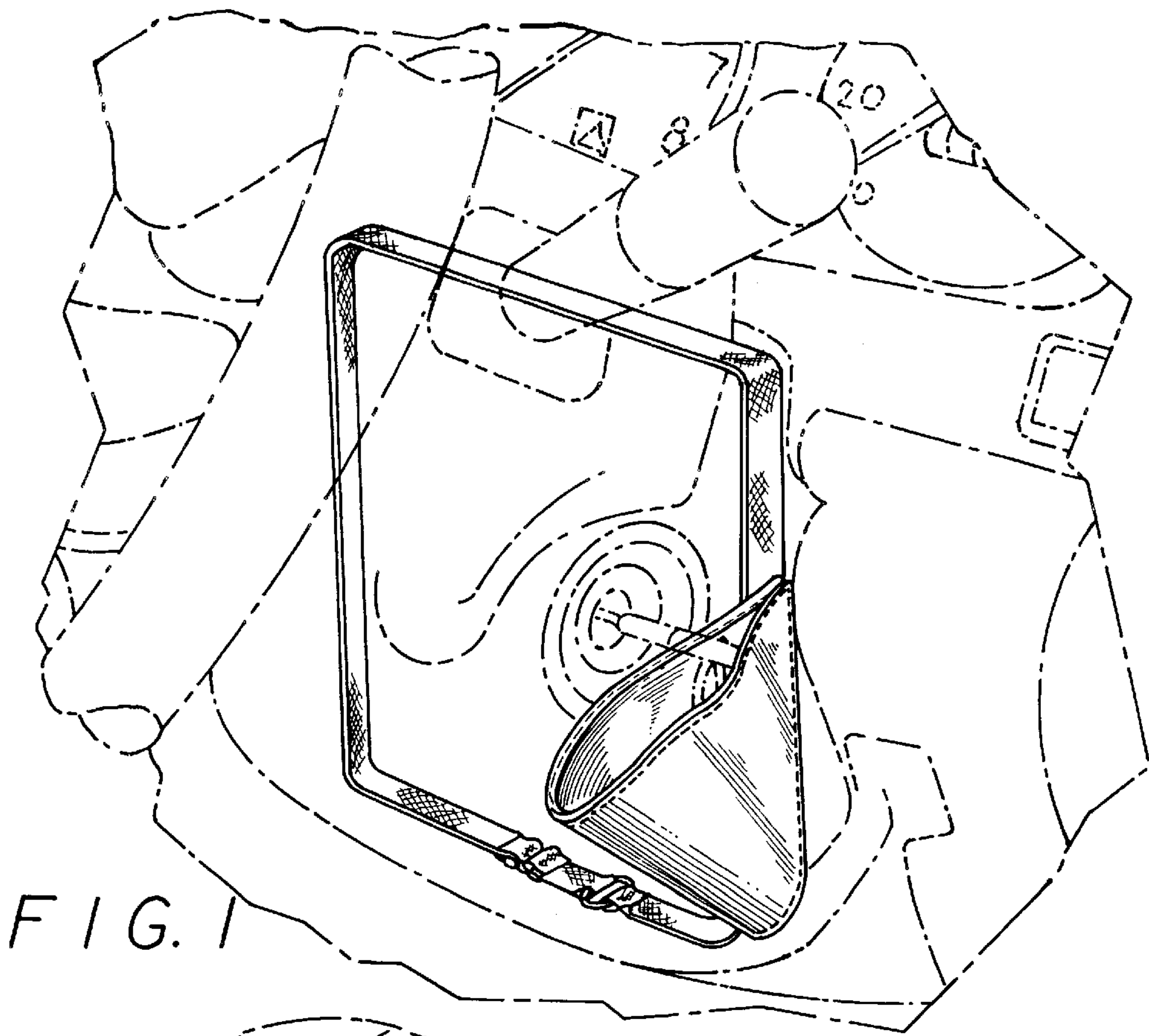

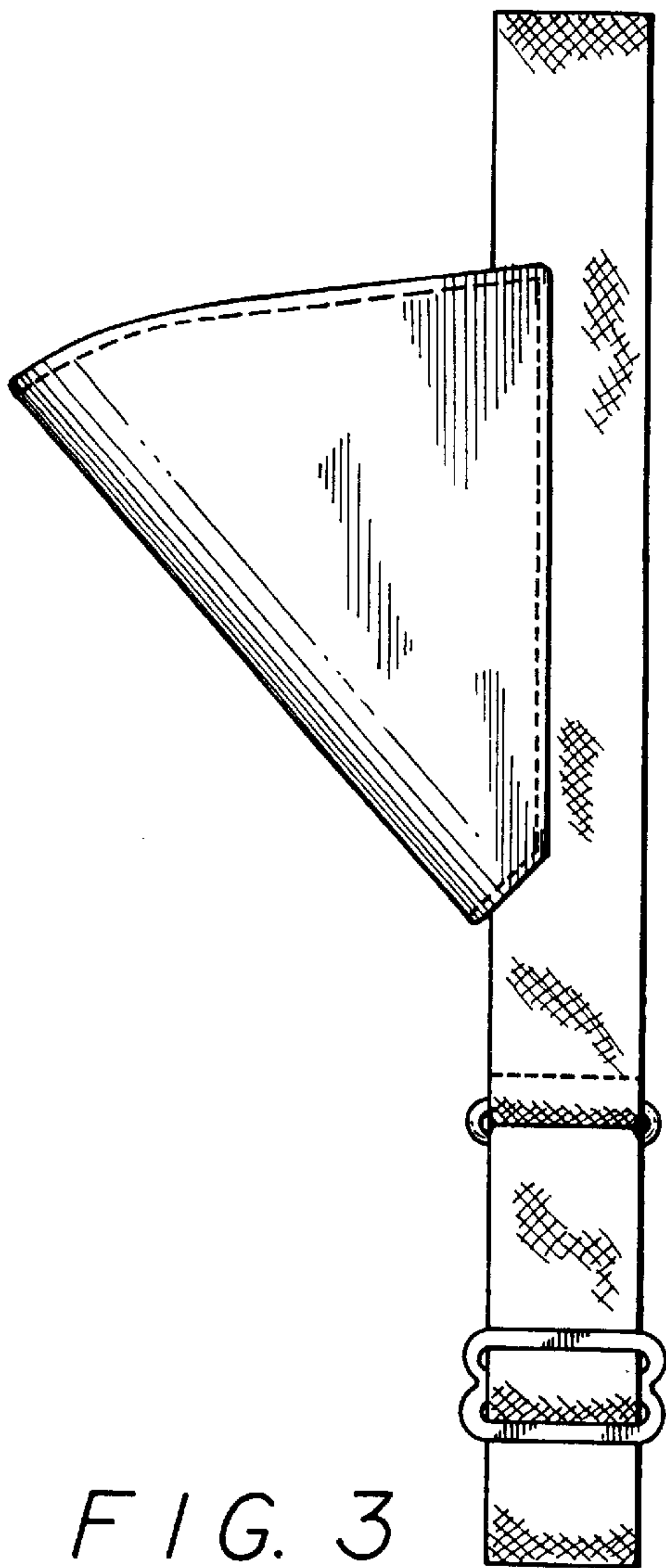

FIG. 3

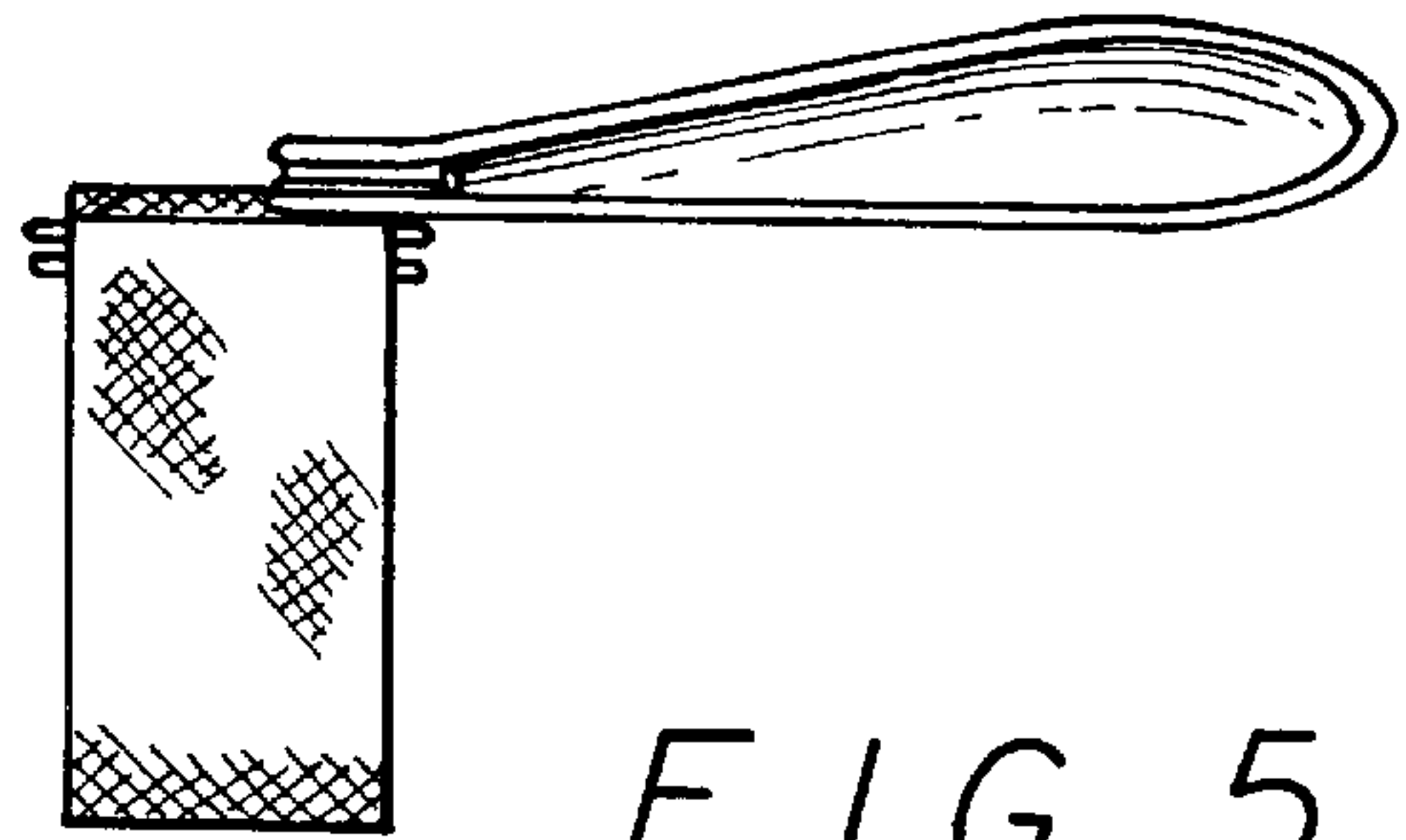

FIG. 5

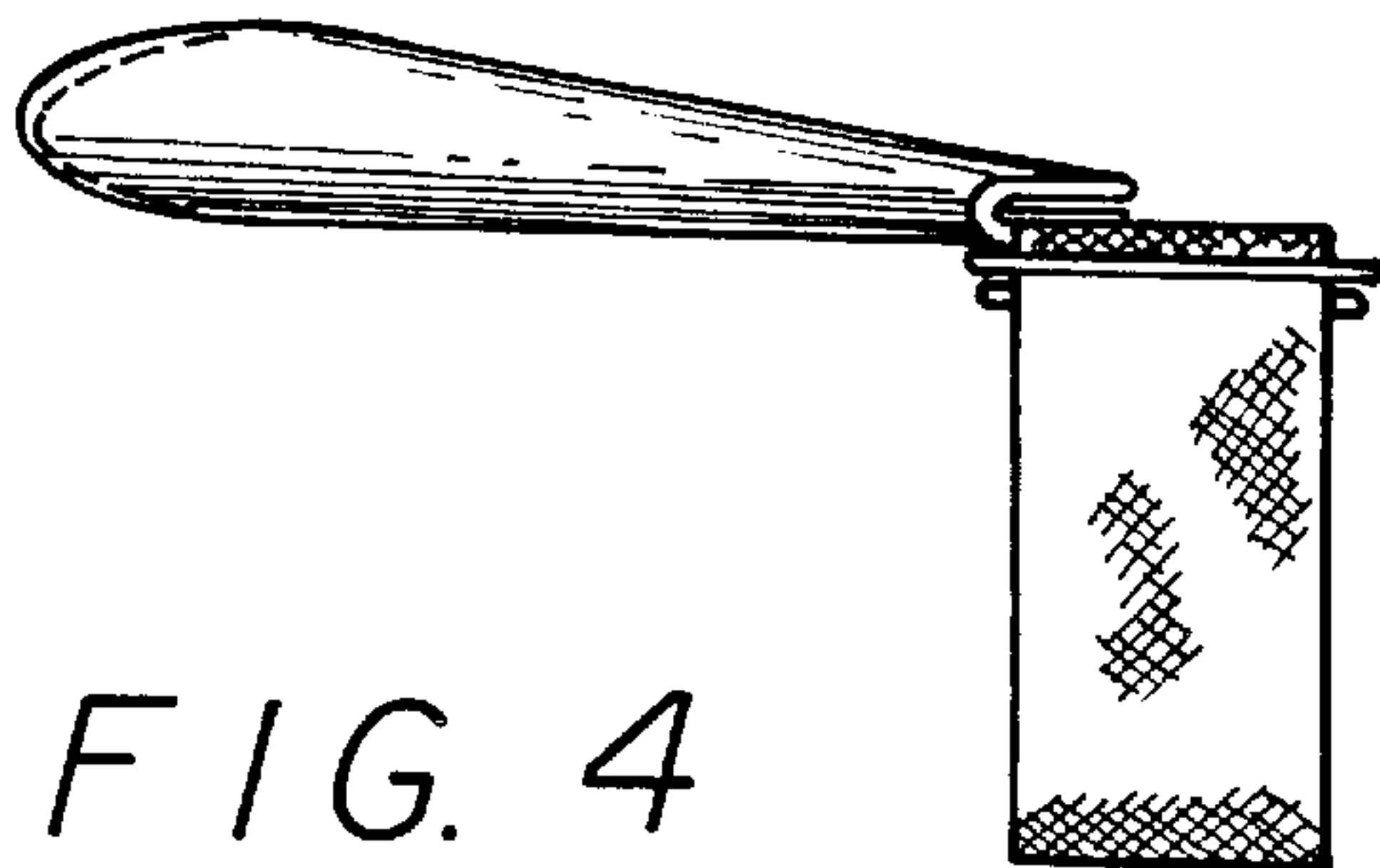

FIG. 4

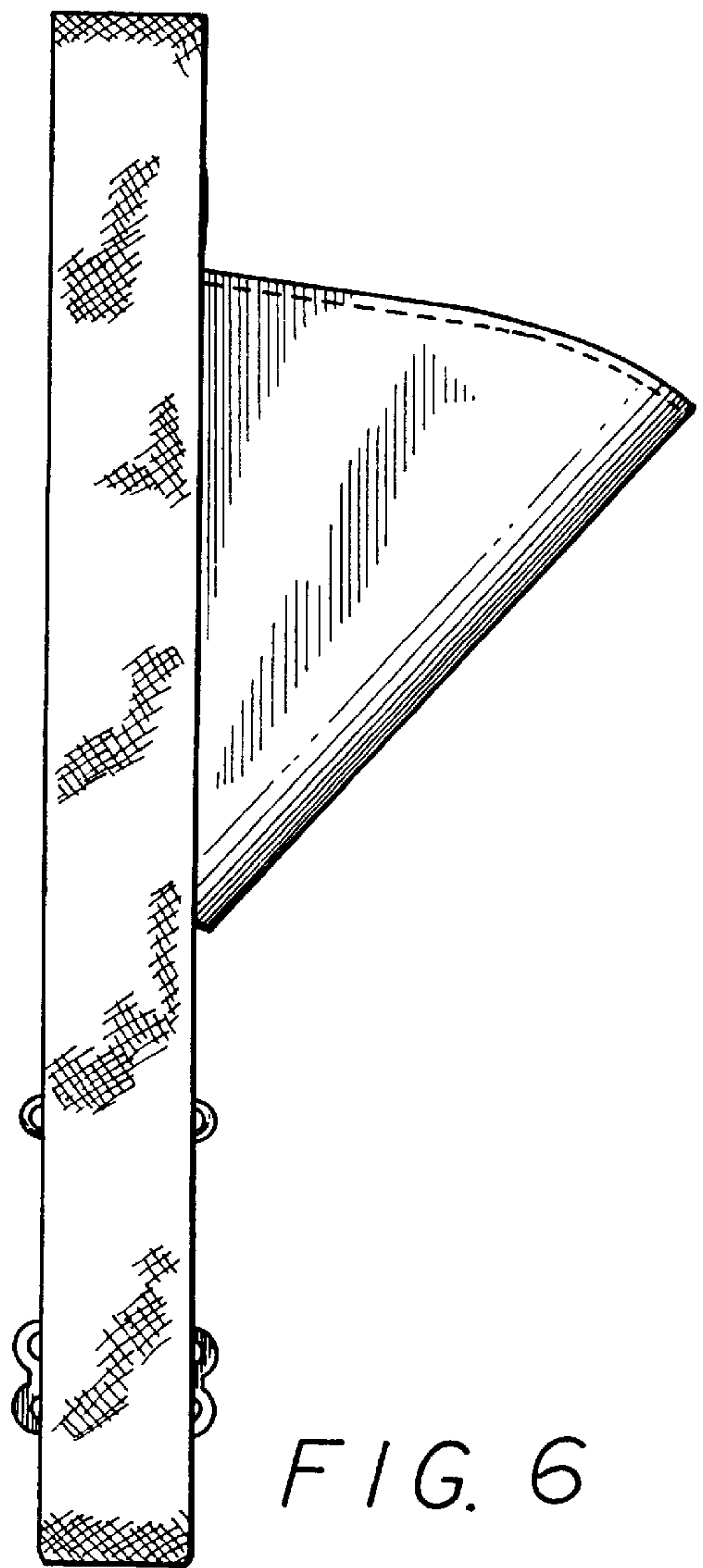

FIG. 6

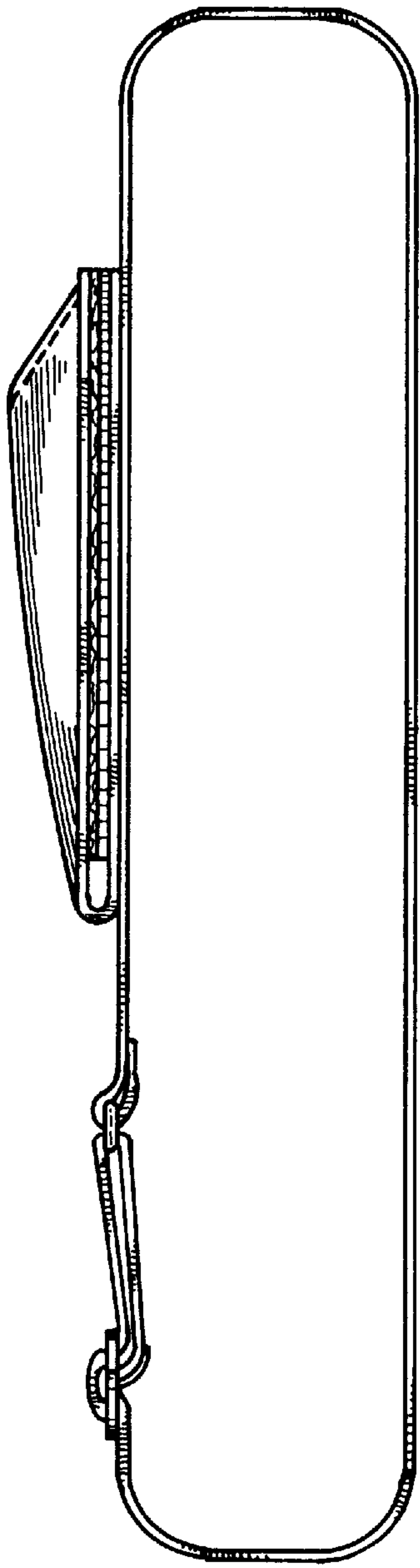

FIG. 7

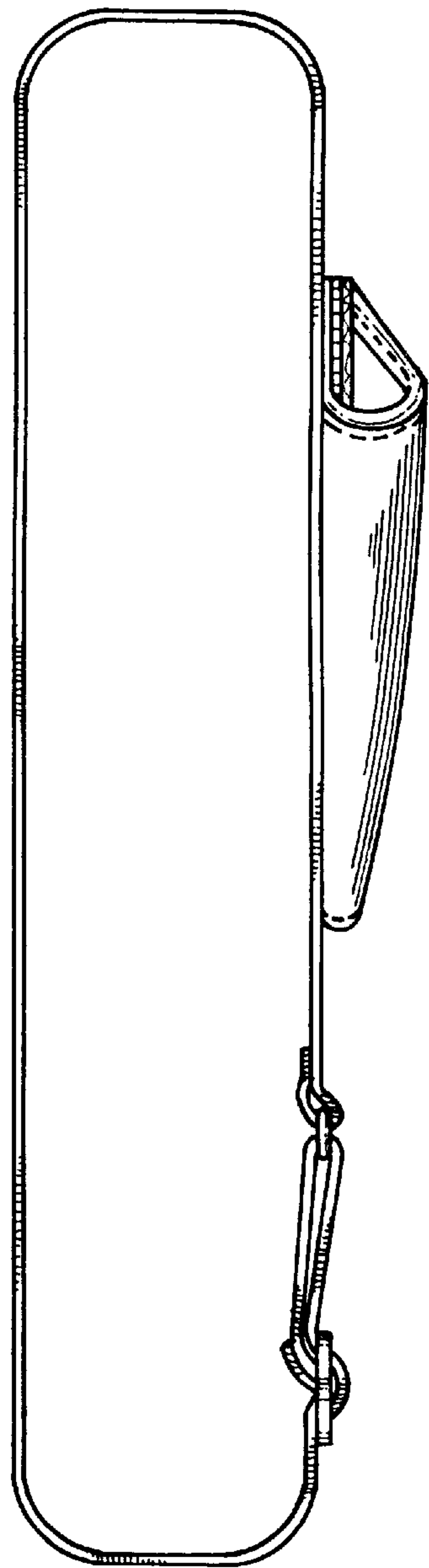

FIG. 8

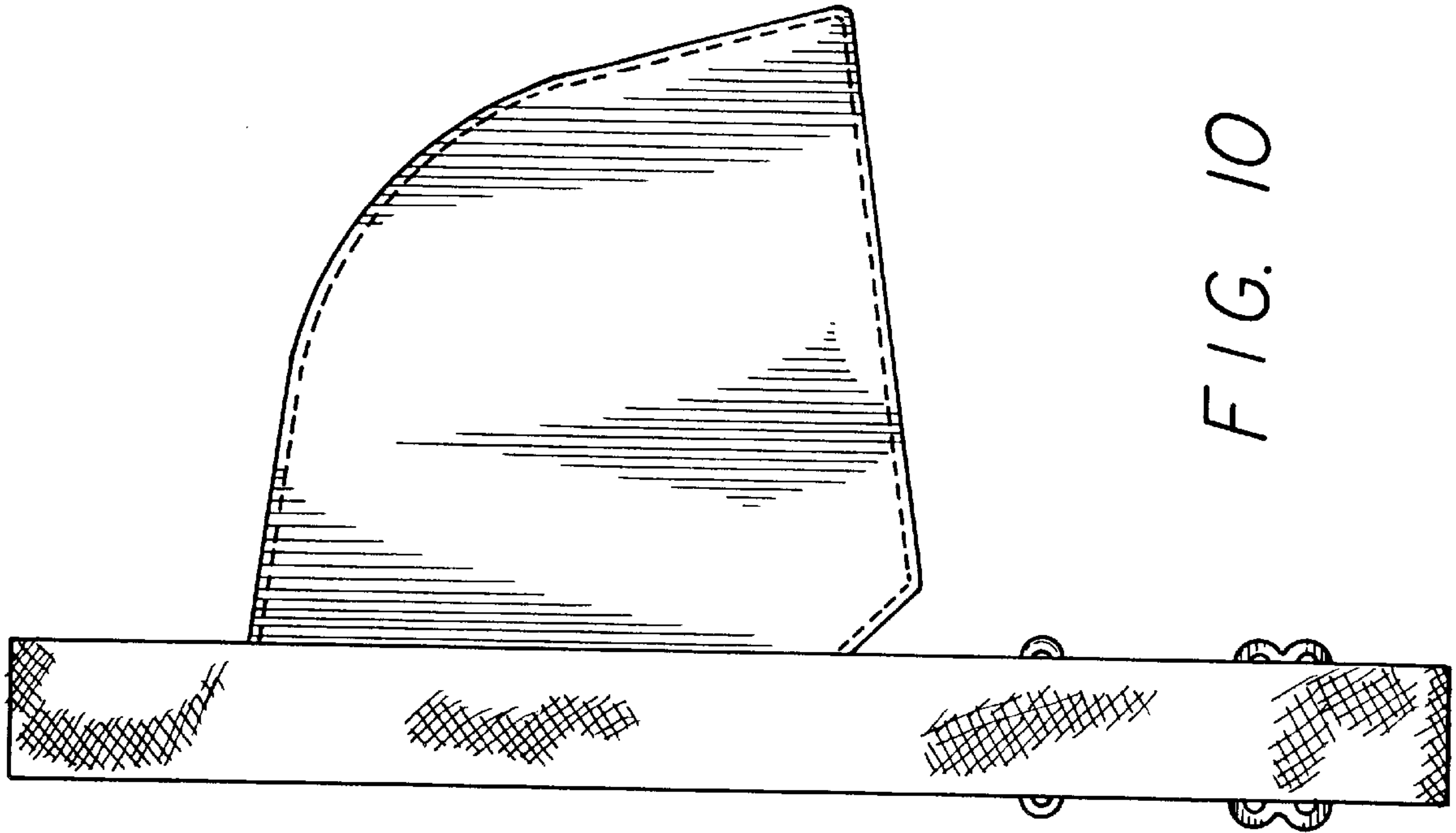

FIG. 10

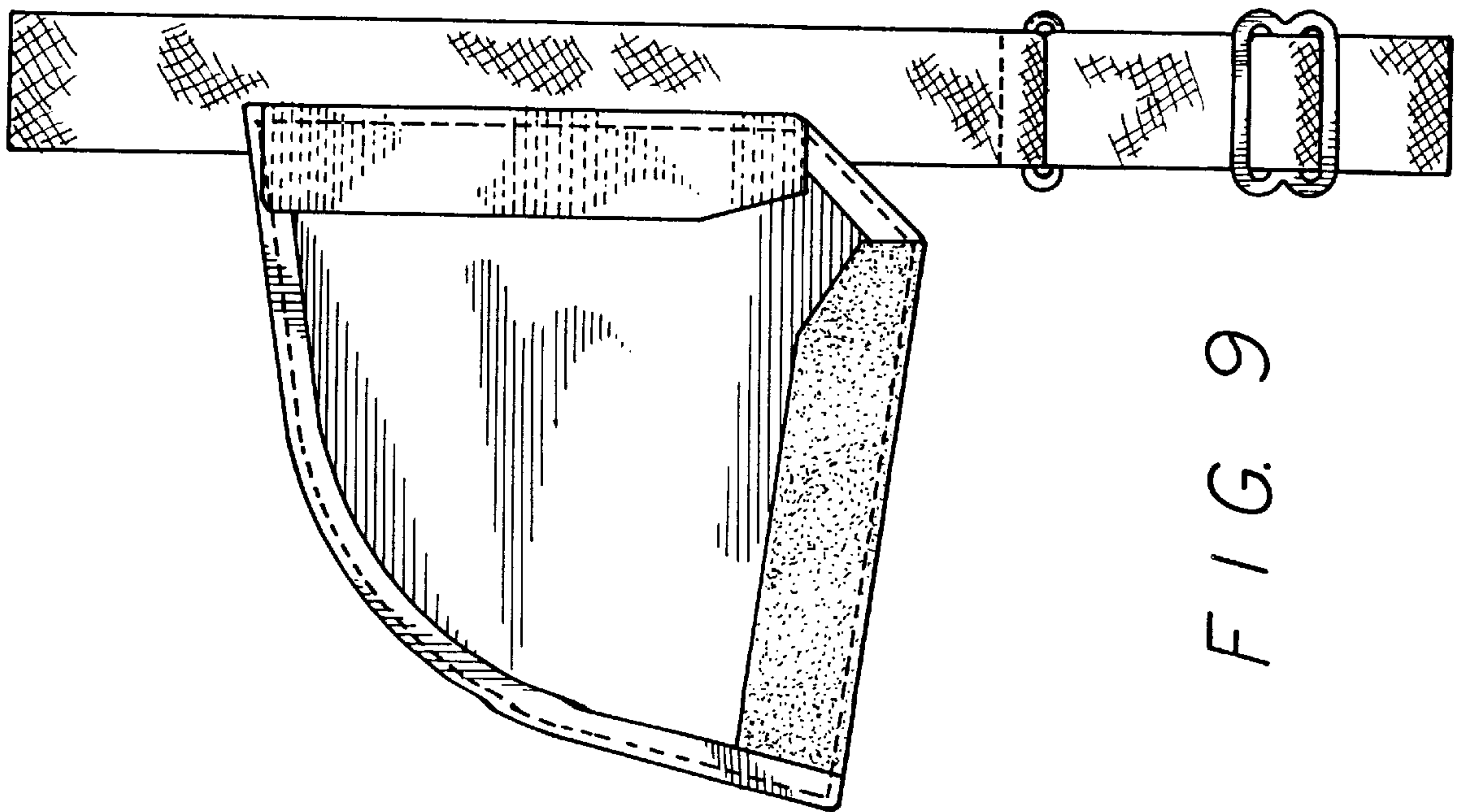

FIG. 9

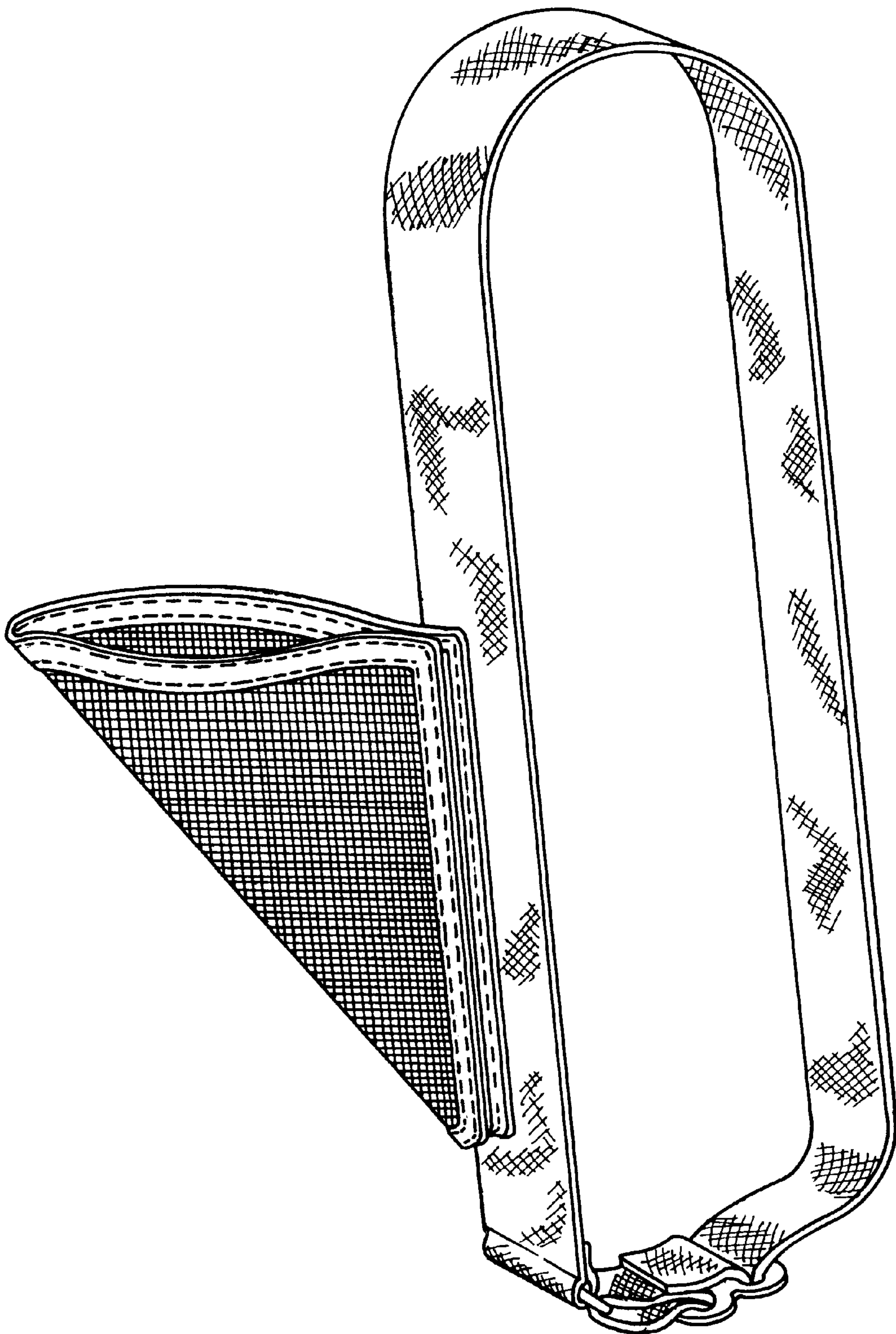

FIG. II