



US00D413561S

United States Patent [19]

Kulla et al.

[11] **Patent Number: Des. 413,561**

[45] **Date of Patent: ** Sep. 7, 1999**

[54] **LOWER SIDE MOLDING OF AN AUTOMOBILE**

D. 323,480 1/1992 Taylor D12/167
D. 351,820 10/1994 Knapp, Jr. D12/190

[75] Inventors: **Matthias Kulla**, Stuttgart; **Otto Geffert**, Besigheim, both of Germany

[73] Assignee: **Dr. Ing. h.c.F. Porsche AG**, Weissach, Germany

[**] Term: **14 Years**

[21] Appl. No.: **29/067,389**

[22] Filed: **Feb. 28, 1997**

[30] **Foreign Application Priority Data**

Aug. 30, 1996 [DE] Germany M 96 07 429

[51] **LOC (6) Cl.** **12-16**

[52] **U.S. Cl.** **D12/190; D12/167; D12/196**

[58] **Field of Search** D12/167, 190, D12/196; 280/770; 293/128; 296/193, 209

[56] **References Cited**

U.S. PATENT DOCUMENTS

D. 160,461 10/1950 Bannister D12/190
D. 161,991 2/1951 Allen D12/190
D. 289,891 5/1987 Bielby D12/190

OTHER PUBLICATIONS

Front cover of Washington D.C. Auto '94 Magazine (National Capital Area International Auto Show Buyers Guide, Jan. 1994.

Primary Examiner—Robert M. Spear
Attorney, Agent, or Firm—Evenson, McKeown, Edwards & Lenahan, P.L.L.C.

[57] **CLAIM**

The ornamental design for a lower side molding of an automobile, as shown and described.

DESCRIPTION

FIG. 1 shows a side view of a lower side molding of an automobile according to our novel design; and, FIG. 2 shows a side perspective view of a lower side molding of an automobile according to our novel design. The broken lines are for illustration only and form no part of the claimed design.

The portions of the lower side molding not depicted in the drawings are not visible to a purchaser or user and therefore form no part of the claimed design.

1 Claim, 1 Drawing Sheet

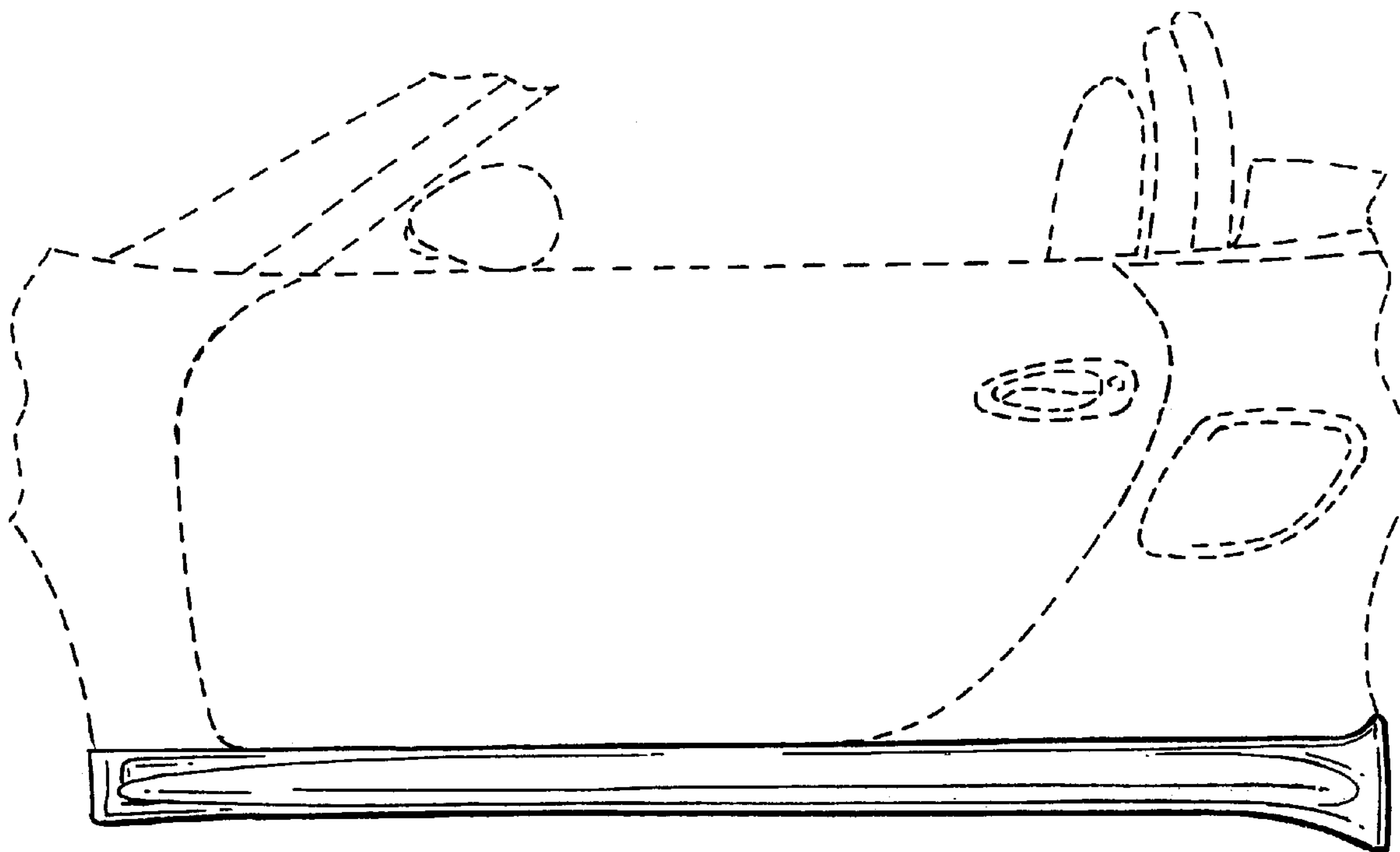

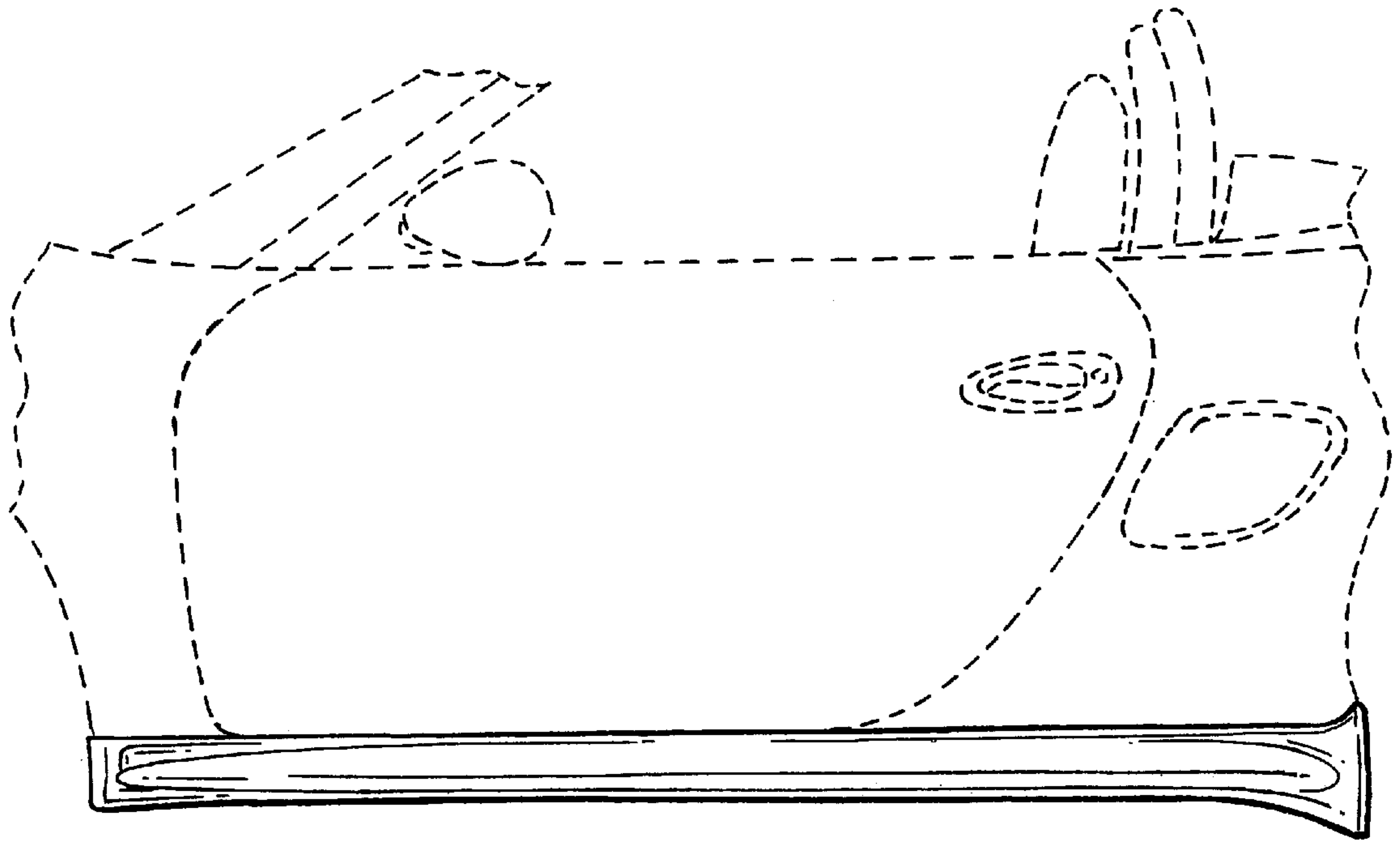

FIG. 1

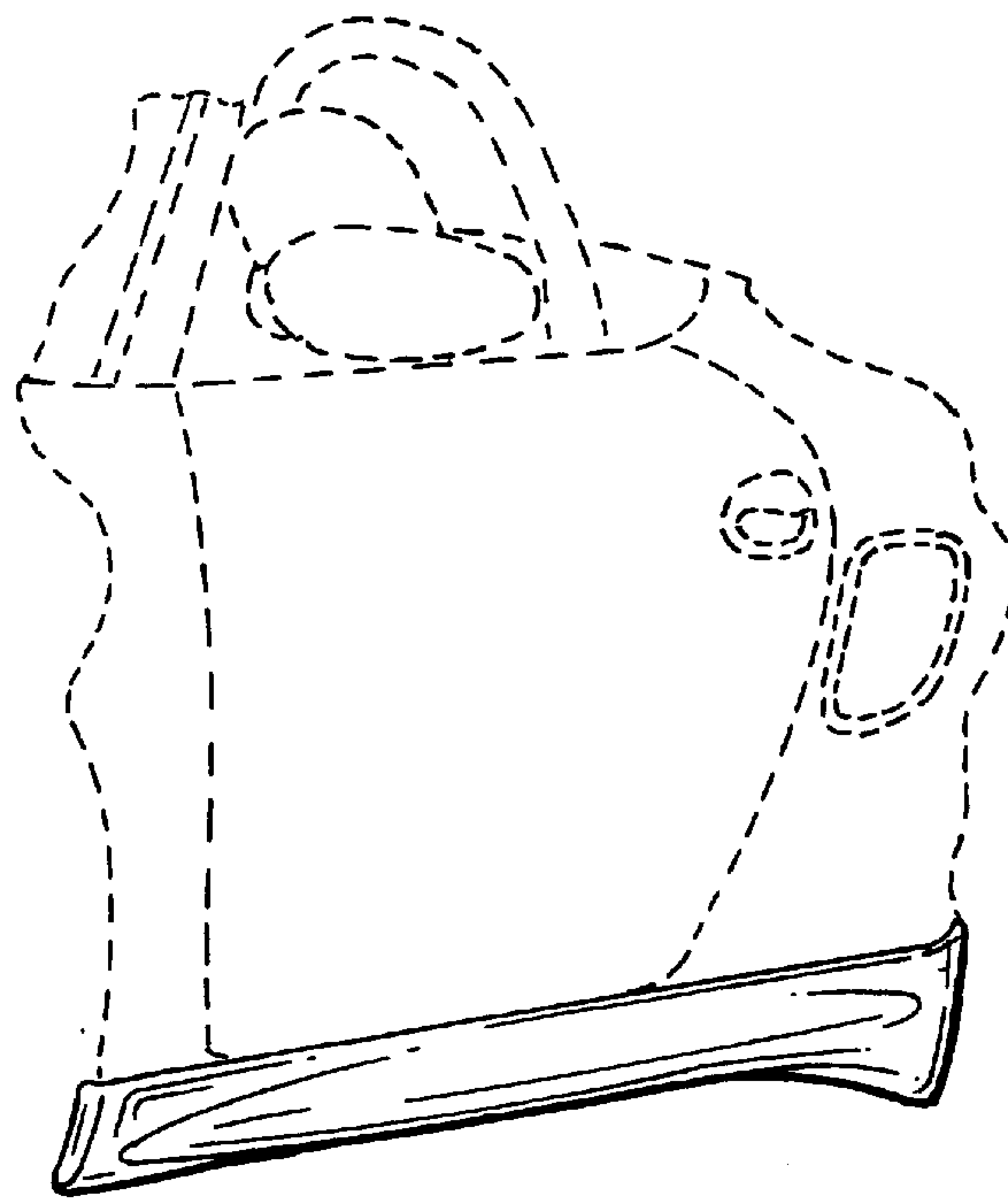

FIG. 2