



US00D413374S

# United States Patent [19] Tine, Jr.

[11] Patent Number: Des. 413,374

[45] Date of Patent: \*\* Aug. 31, 1999

[54] MANUAL FUEL VALVE

[75] Inventor: Theodore Joseph Tine, Jr., Chester, Conn.

[73] Assignee: Essex Motorsports International, Inc., Chester, Conn.

[\*\*] Term: 14 Years

[21] Appl. No.: 29/093,424

[22] Filed: Sep. 10, 1998

[51] LOC (6) Cl. .... 23-01

[52] U.S. Cl. .... D23/233

[58] Field of Search ..... D23/233-237, D23/245; 137/544, 590; 251/288

### [56] References Cited

#### U.S. PATENT DOCUMENTS

D. 330,712	11/1992	Pingel et al. ....	D15/5
D. 363,533	10/1995	Pingel et al. ....	D23/233
D. 363,762	10/1995	Pingel et al. ....	D23/233
2,673,571	3/1954	Lerom .....	137/590
3,291,184	12/1966	Varvel .....	158/36.3
4,250,921	2/1981	Pingel et al. ....	137/625.41
4,957,138	9/1990	Pingel et al. ....	137/549
5,115,837	5/1992	Tupper .....	137/625.41
5,211,194	5/1993	Scott et al. ....	137/590
5,303,685	4/1994	Forgacs .....	137/624.41

#### FOREIGN PATENT DOCUMENTS

1202003 1/1960 France .

Primary Examiner—Robin V. Taylor  
Attorney, Agent, or Firm—St. Onge Steward Johnston & Reens LLC

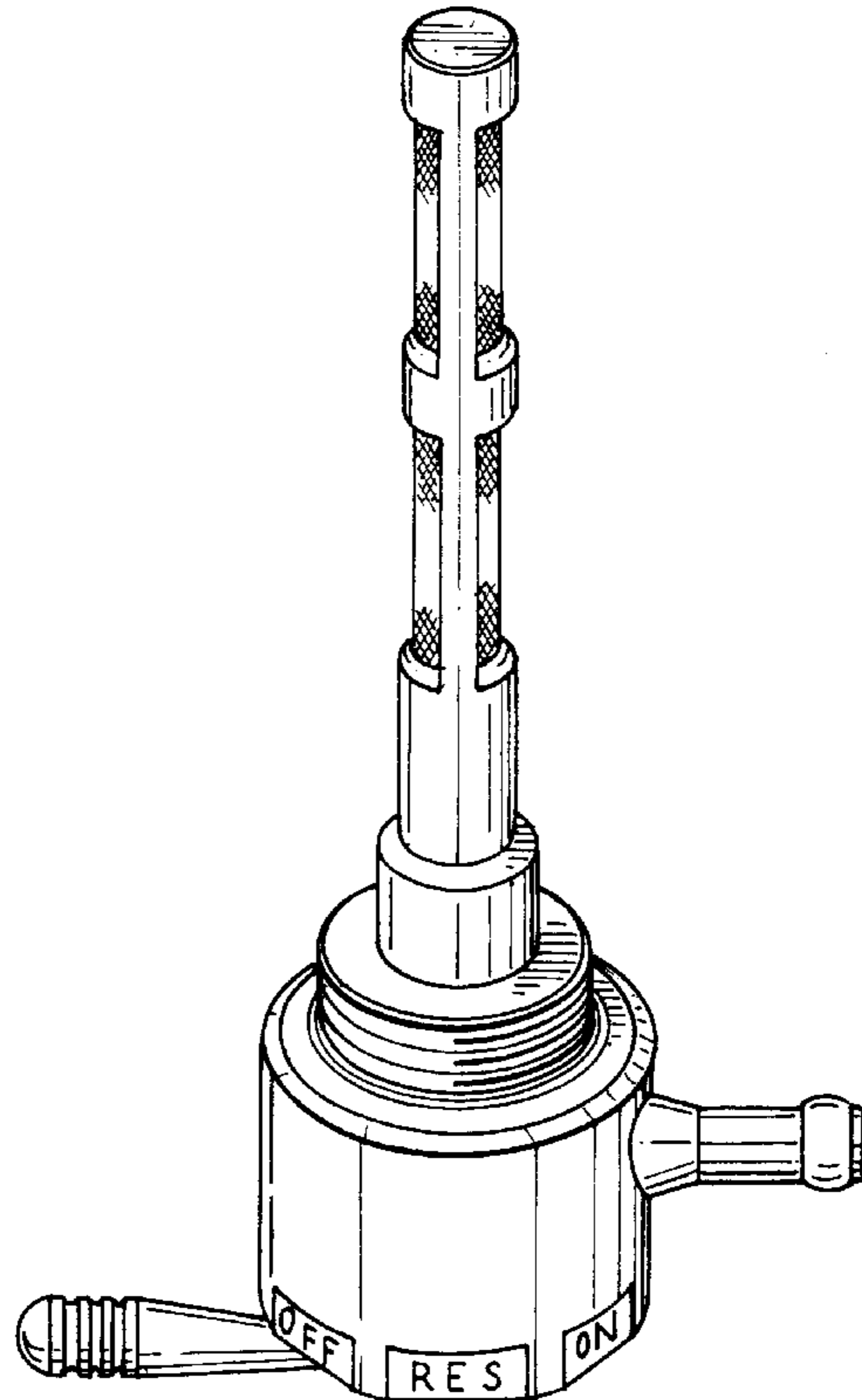
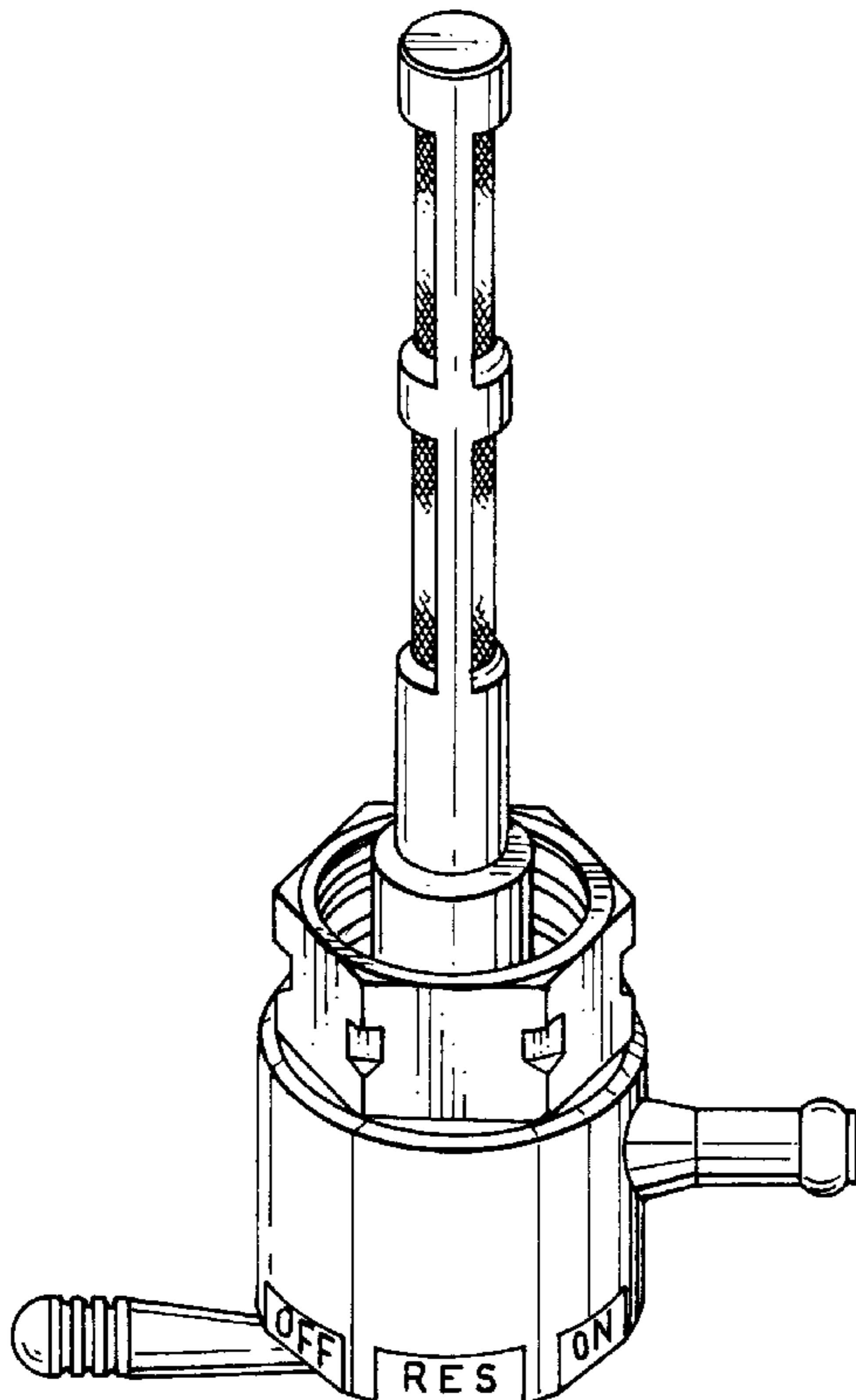
### [57] CLAIM

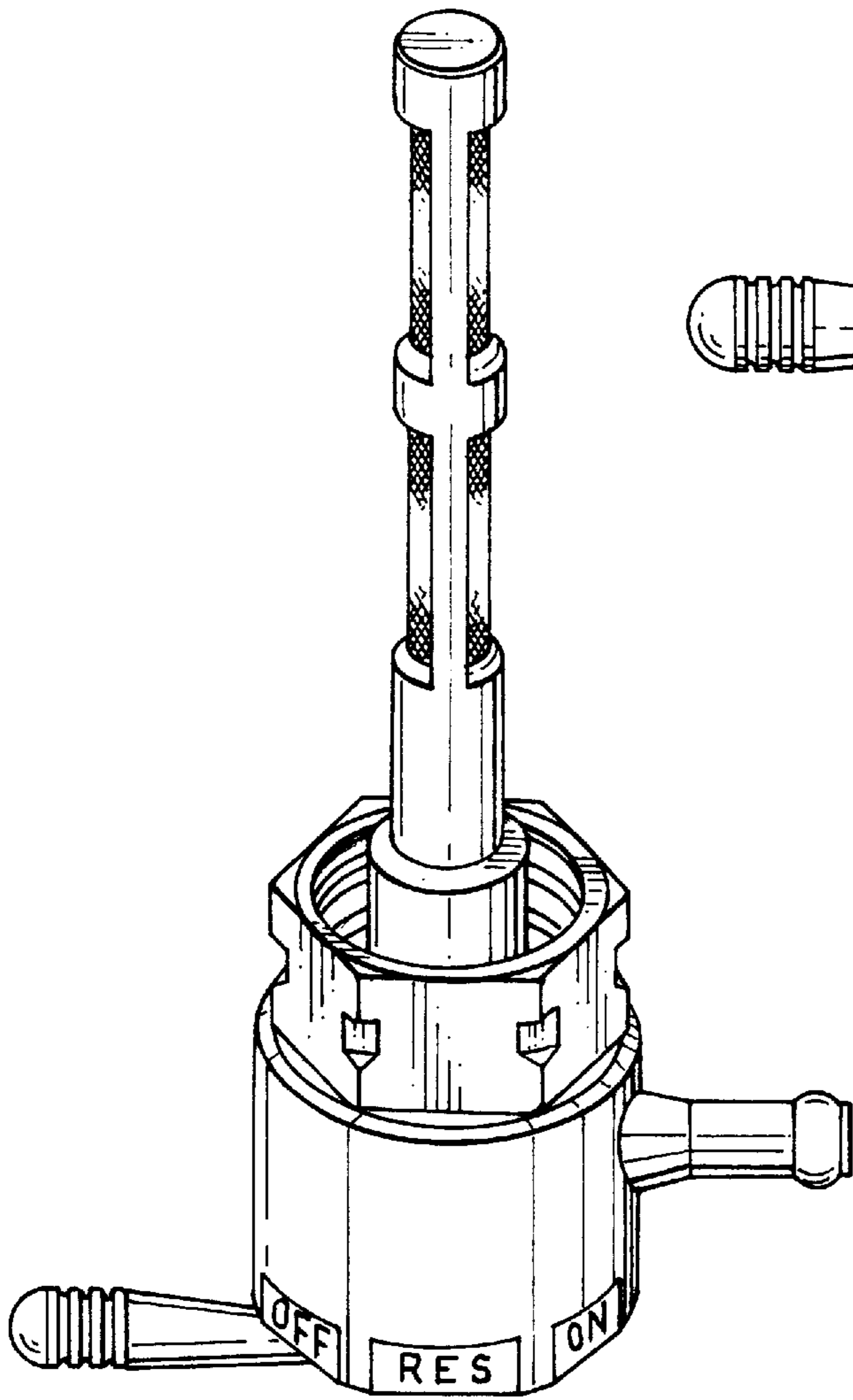
The ornamental design for a manual fuel valve, as shown and described.

### DESCRIPTION

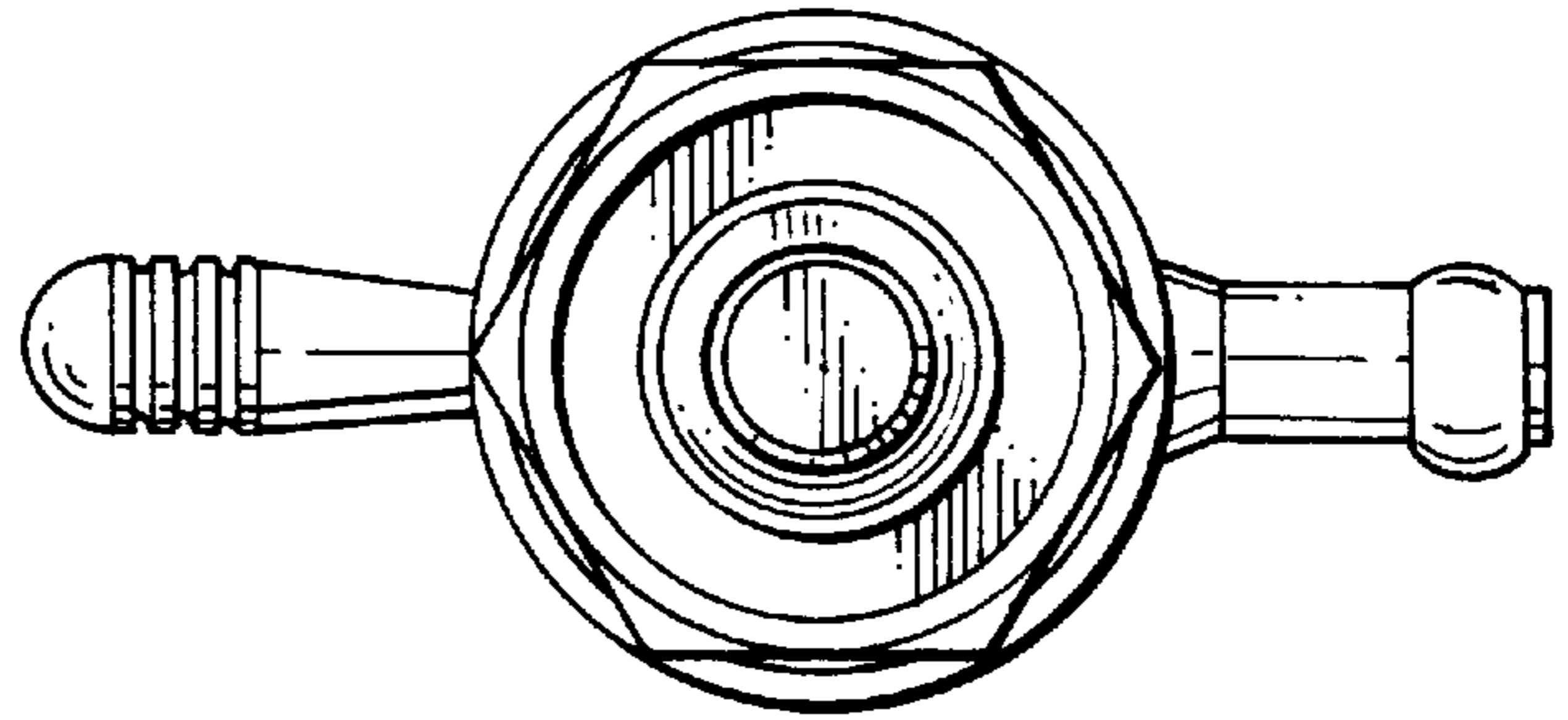
FIG. 1 is a perspective view of a manual fuel valve in accordance with the invention;  
 FIG. 2 is a front view in elevation of the manual fuel valve of FIG. 1;  
 FIG. 3 is a back view in elevation of the manual fuel valve of FIG. 2;  
 FIG. 4 is one side view in elevation of the manual fuel valve of FIG. 2;  
 FIG. 5 is another side view in elevation of the manual fuel valve of FIG. 2 and opposite to that of that of FIG. 4;  
 FIG. 6 is a bottom view of the manual fuel valve of FIG. 2;  
 FIG. 7 is a top view of the manual fuel valve of FIG. 2;  
 FIG. 8 is a perspective view of another embodiment of the manual fuel valve of FIG. 1 without the hexagonal mounting nut shown therein;  
 FIG. 9 is a front view in elevation of the manual fuel valve of FIG. 8;  
 FIG. 10 is one side view in elevation of the manual fuel valve of FIG. 9 with the other opposite side view in elevation being the same as in FIG. 5 without the hexagonal nut shown therein; and,  
 FIG. 11 is a top view of the manual fuel valve of FIG. 9 with the bottom view being the same as shown in FIG. 6.

1 Claim, 3 Drawing Sheets

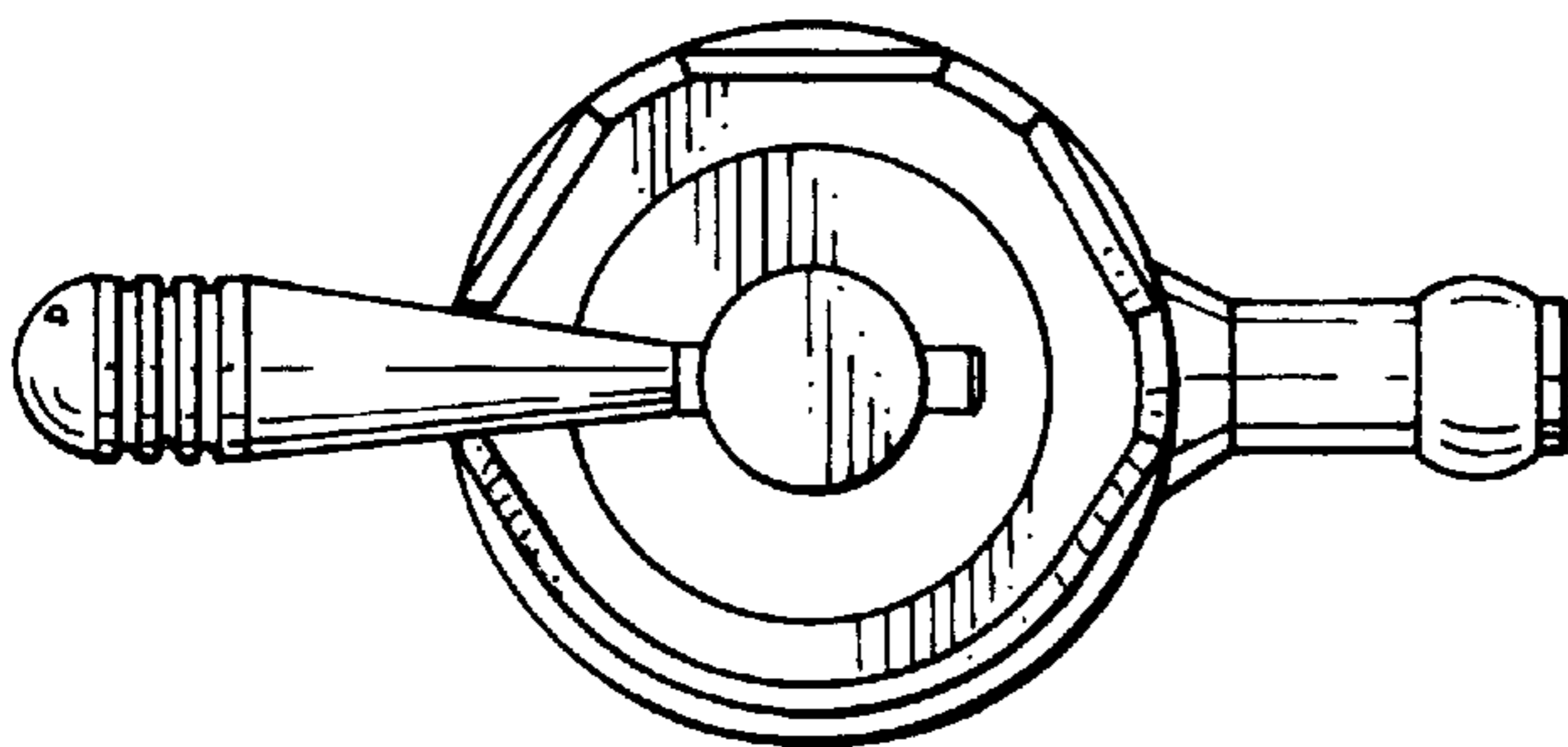




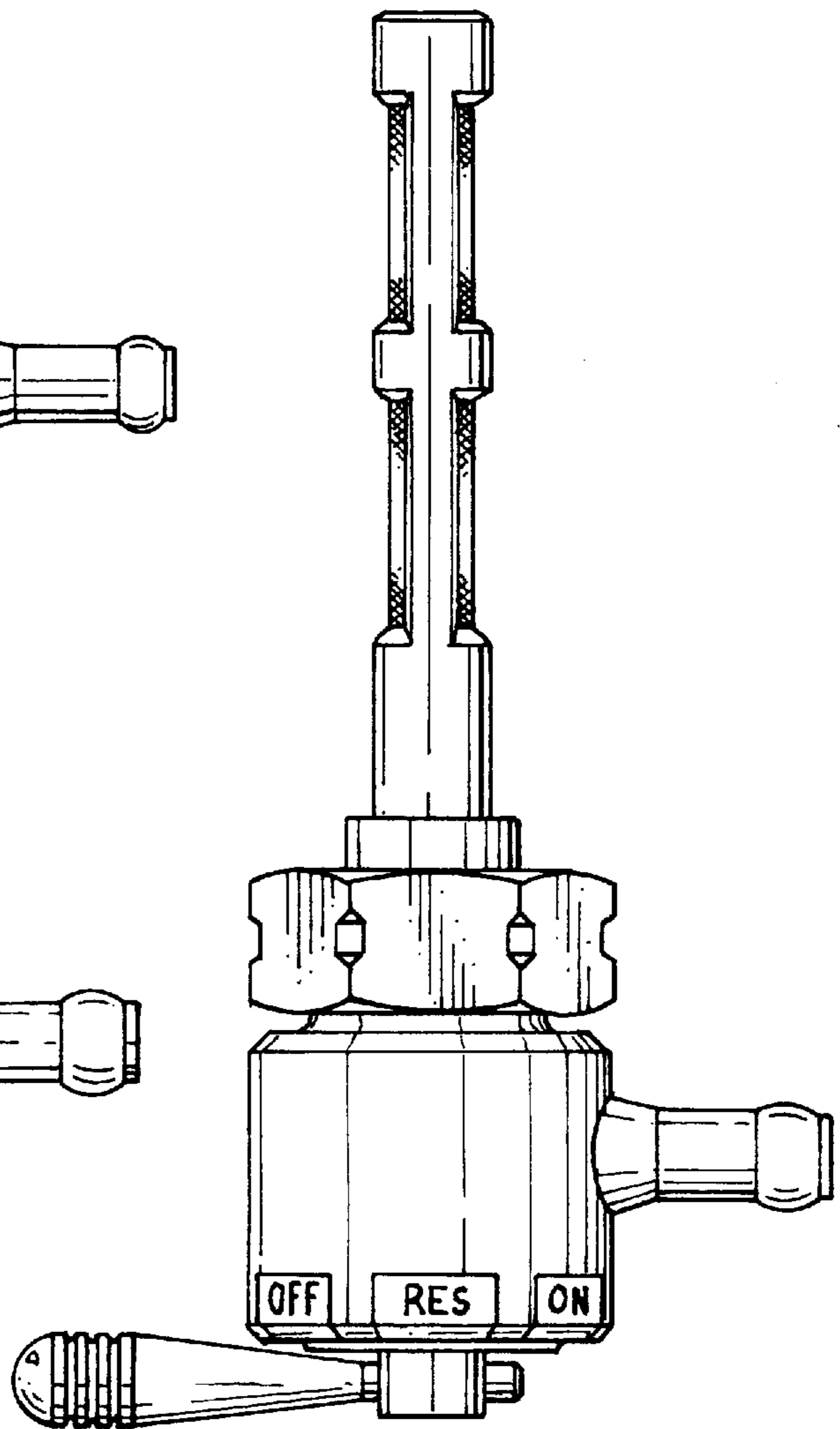
*FIG. 1*



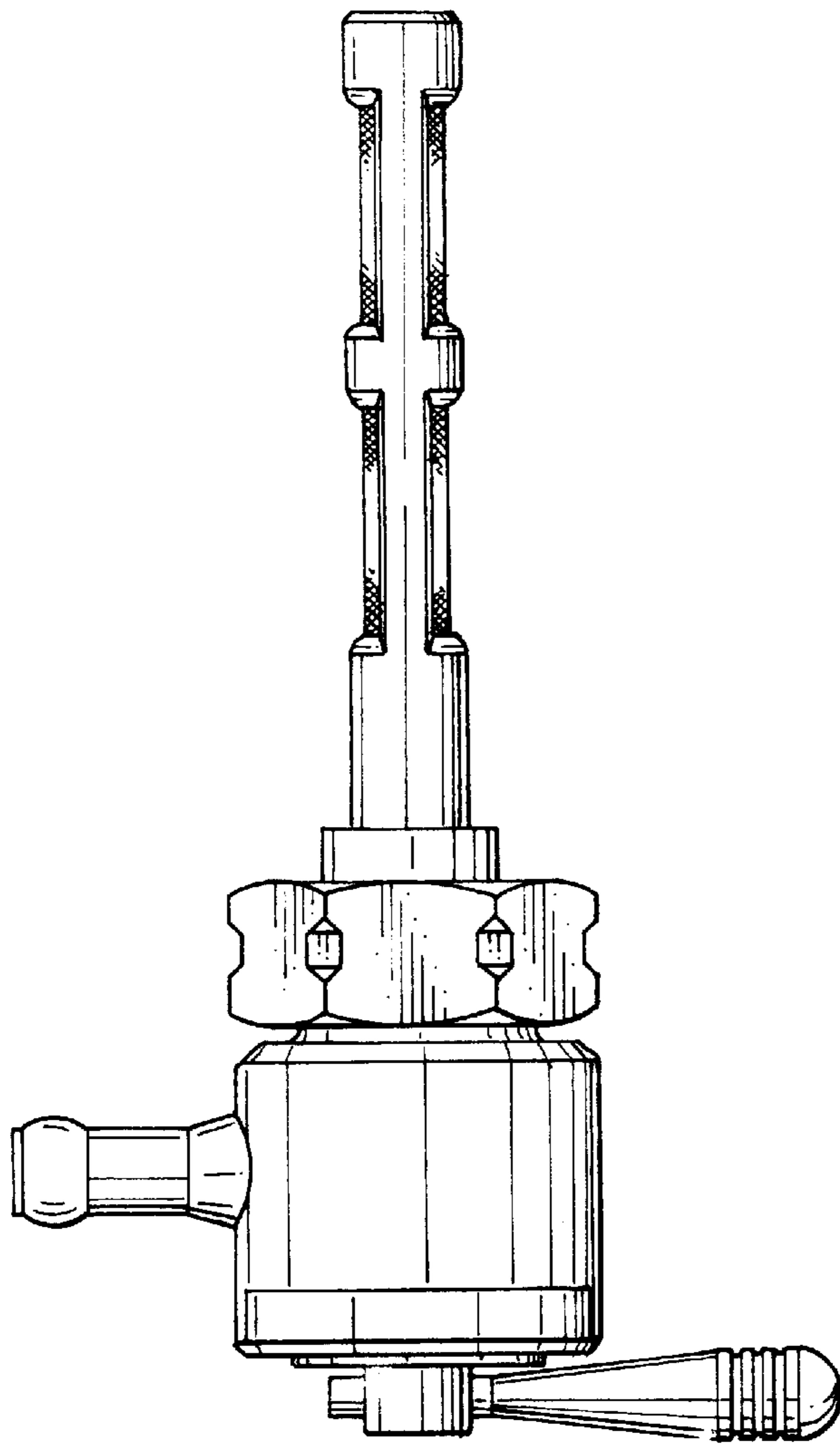
*FIG. 7*



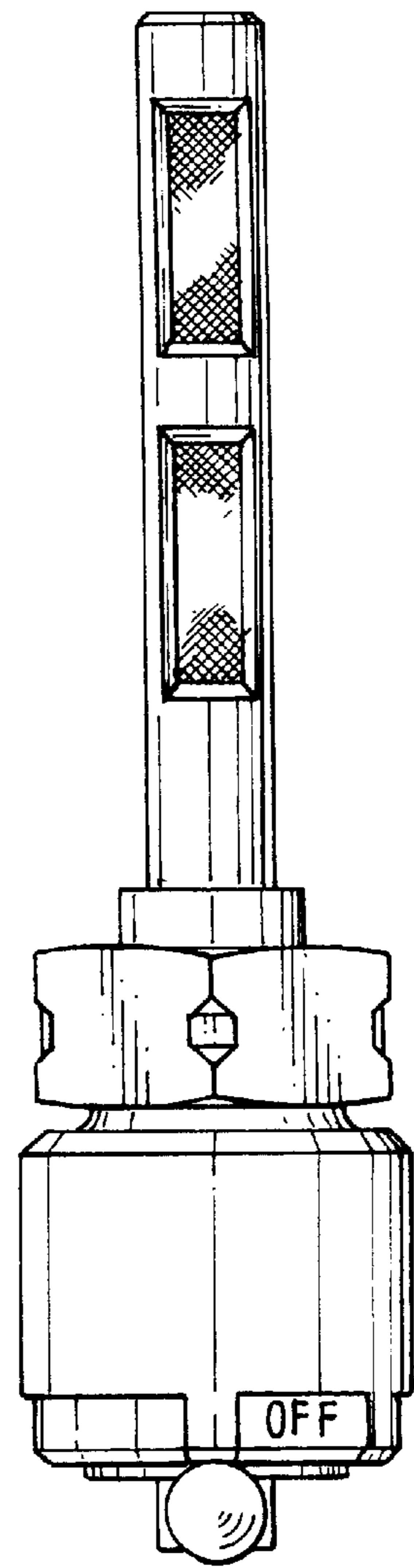
*FIG. 6*



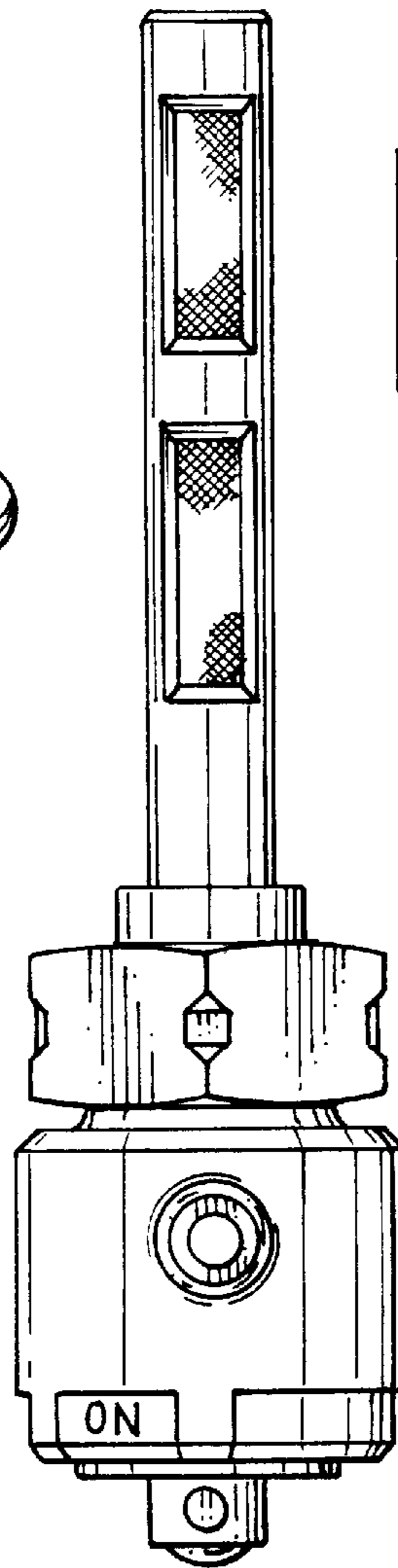
*FIG. 2*



*FIG. 3*



*FIG. 5*



*FIG. 4*

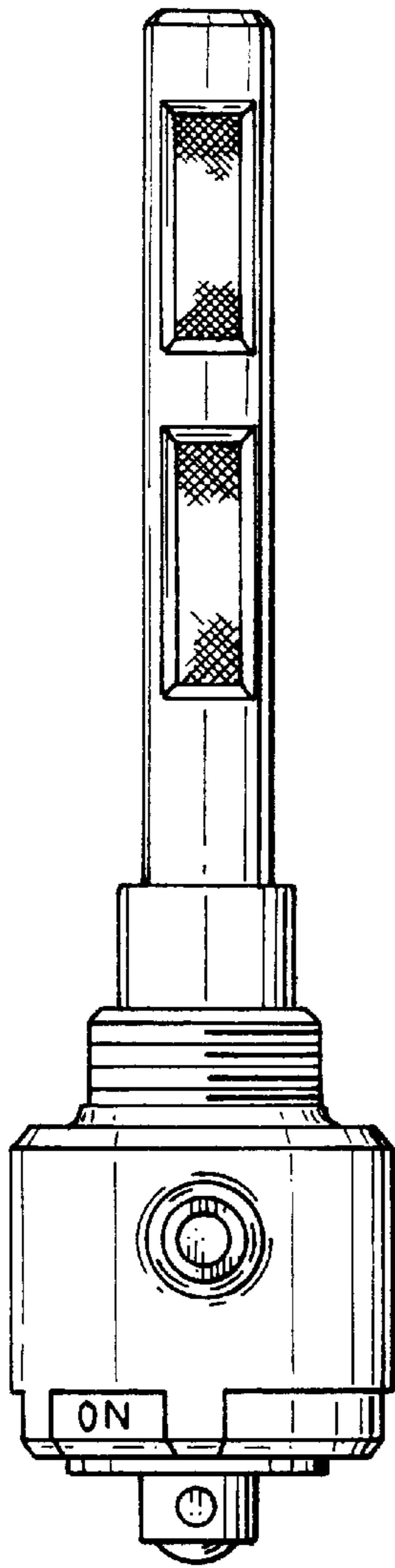


FIG. 10

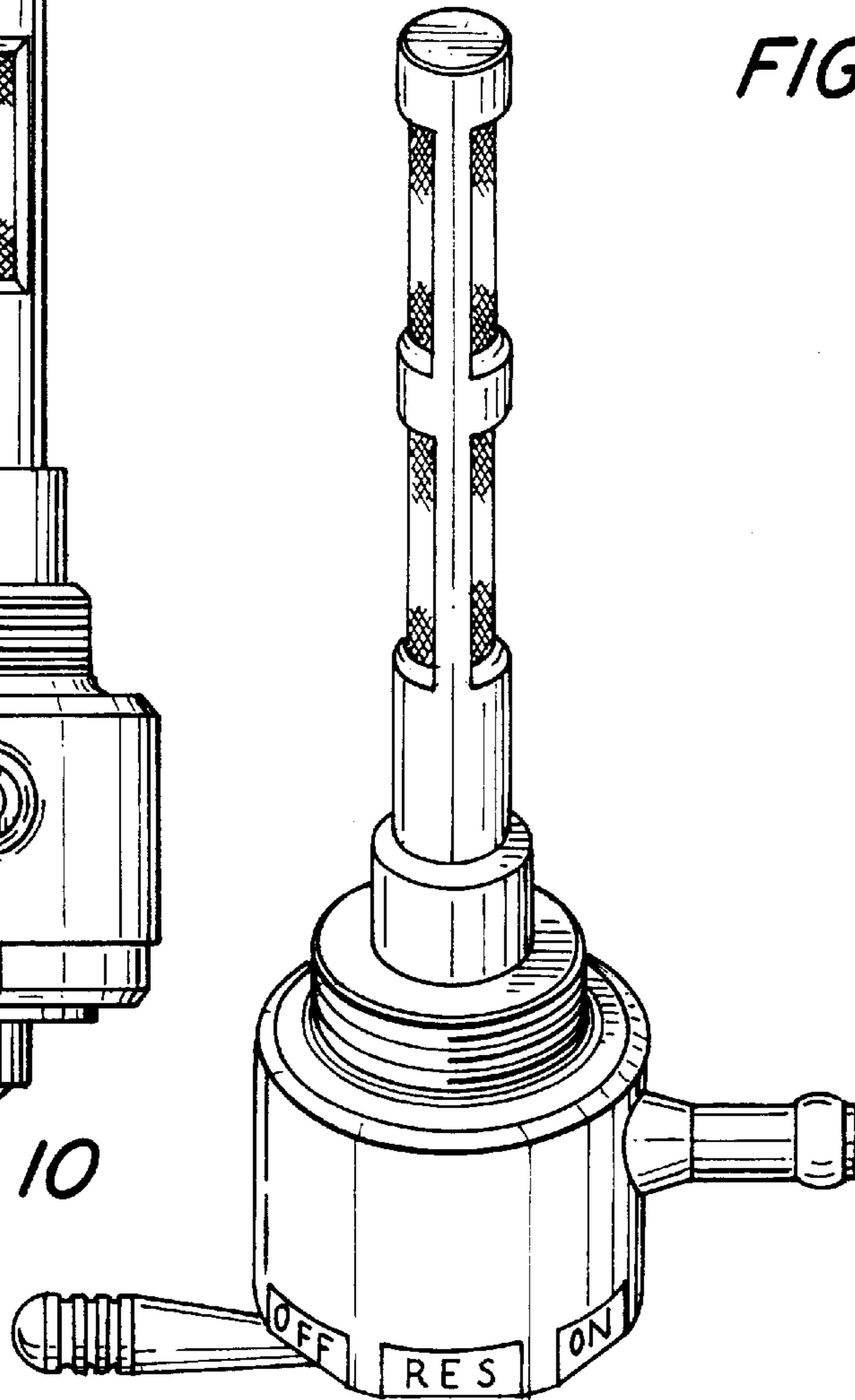


FIG. 8

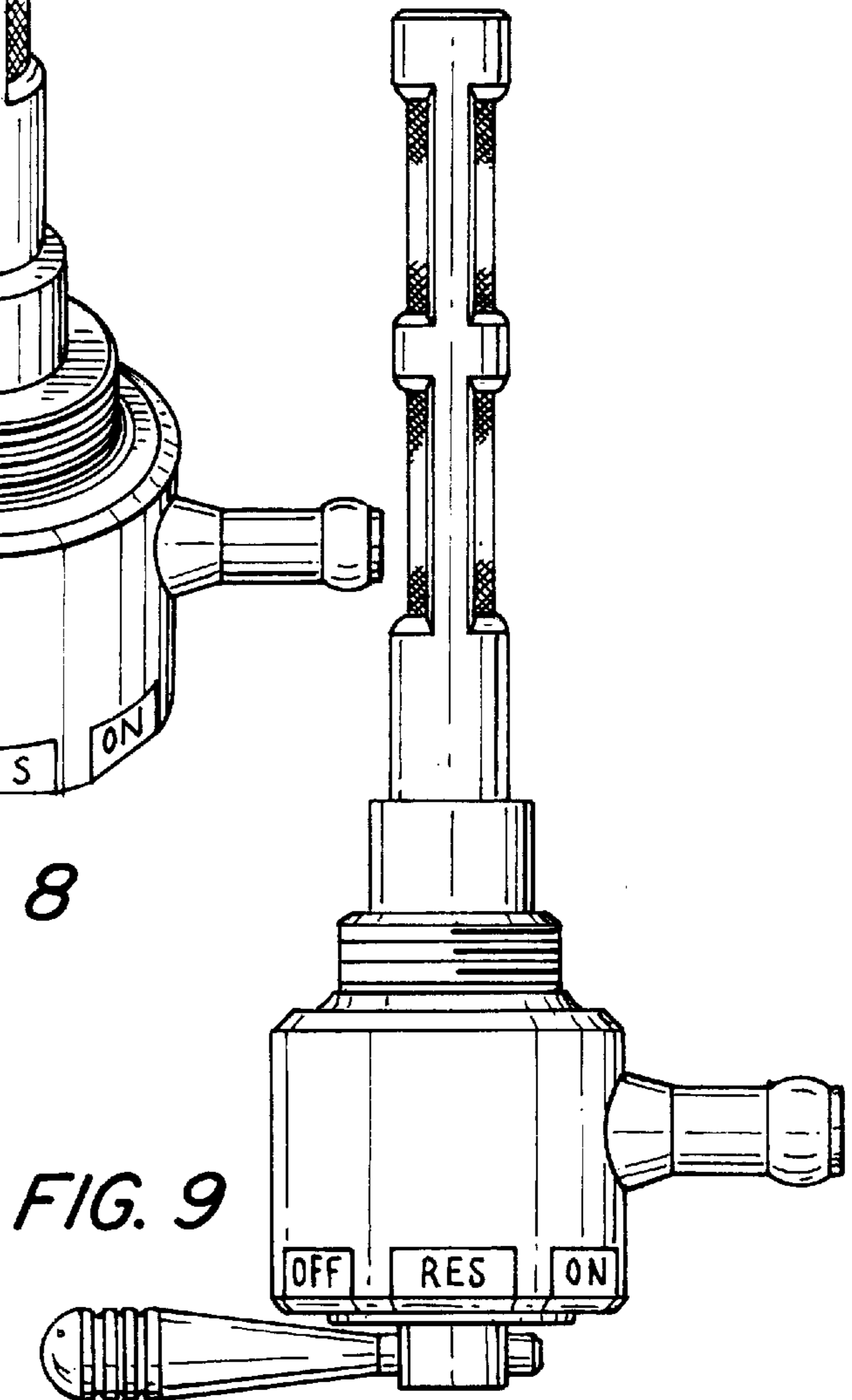


FIG. 9

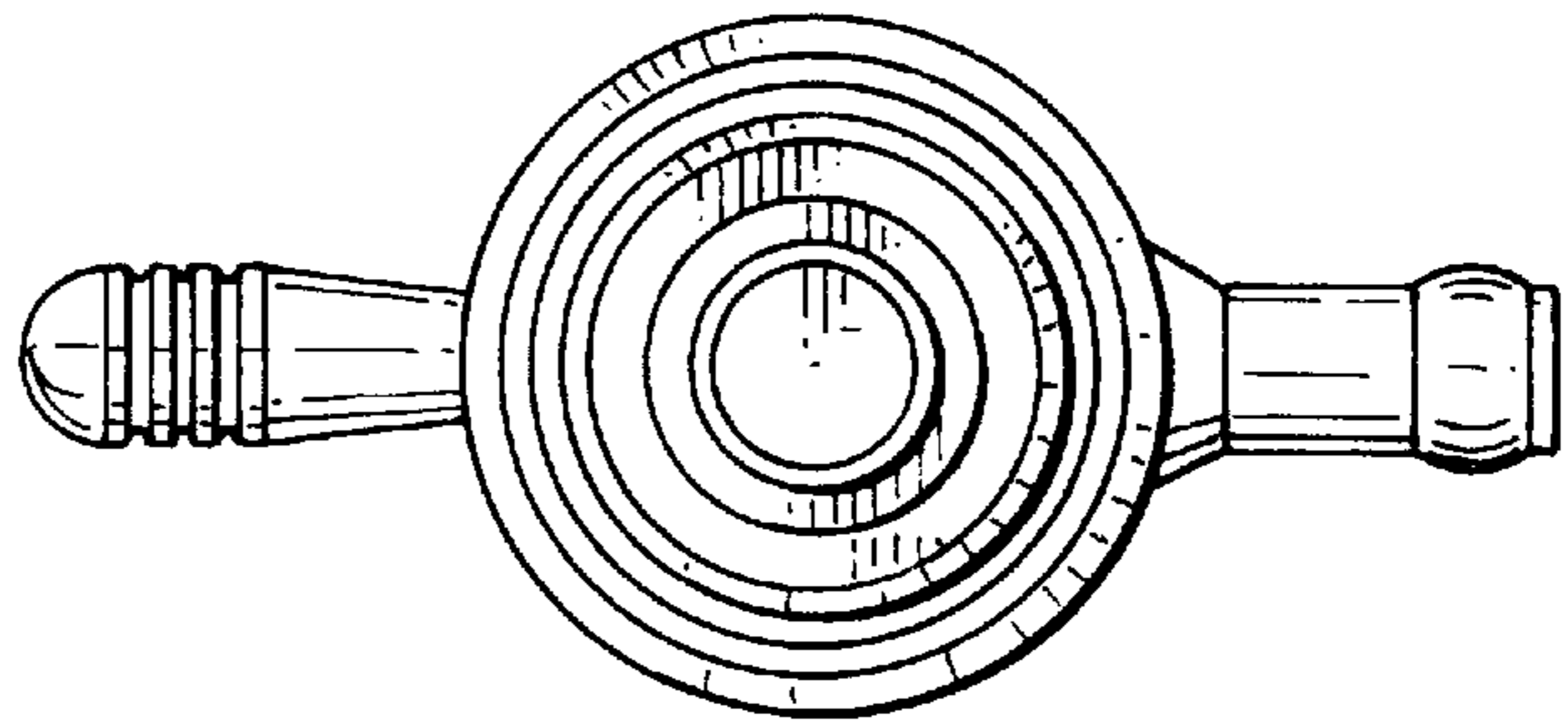


FIG. 11