



US00D413314S

United States Patent [19] Morimiya

[11] **Patent Number: Des. 413,314**

[45] **Date of Patent: ** Aug. 31, 1999**

[54] **MONITOR**

[75] Inventor: **Yuji Morimiya**, Tokyo, Japan

[73] Assignee: **Sony Corporation**, Tokyo, Japan

[**] Term: **14 Years**

[21] Appl. No.: **29/085,134**

[22] Filed: **Mar. 17, 1998**

[51] **LOC (6) Cl. 14-02**

[52] **U.S. Cl. D14/113; D14/126**

[58] **Field of Search** D14/100, 101,
D14/106, 113, 124-129; 248/918-924;
341/12; 345/104, 133, 156, 168, 87, 173,
901-905; 348/180, 184, 325, 739

[56] **References Cited**

U.S. PATENT DOCUMENTS

D. 309,896	8/1990	Schaum	D14/113
D. 328,066	7/1992	Couch	D14/113
D. 332,092	12/1992	Lo	D14/113

OTHER PUBLICATIONS

Catalog "87", pp. 211 & 212, Sony (Nov. 1997).

Primary Examiner—Freda Nunn

Attorney, Agent, or Firm—Foley & Lardner

[57] **CLAIM**

The ornamental design for a monitor, as shown and described.

DESCRIPTION

FIG. 1 is a perspective view of a first embodiment of a monitor showing my new design;
 FIG. 2 is a top plan view of the first embodiment;
 FIG. 3 is a left side elevational view thereof;
 FIG. 4 is a right side elevational view thereof;
 FIG. 5 is a front elevational view thereof;
 FIG. 6 is a perspective view of a second embodiment of a monitor showing my new design;
 FIG. 7 is a top plan view thereof;
 FIG. 8 is a bottom plan view thereof;
 FIG. 9 is a left side elevational view thereof;
 FIG. 10 is a right side elevational view thereof;
 FIG. 11 is a front elevational view thereof;
 FIG. 12 is a rear elevational view of the first embodiment;
 and,
 FIG. 13 is a rear elevational view of the second embodiment.
 The bottom plan view of the first embodiment is the same as the bottom view as shown in FIG. 8.

1 Claim, 11 Drawing Sheets

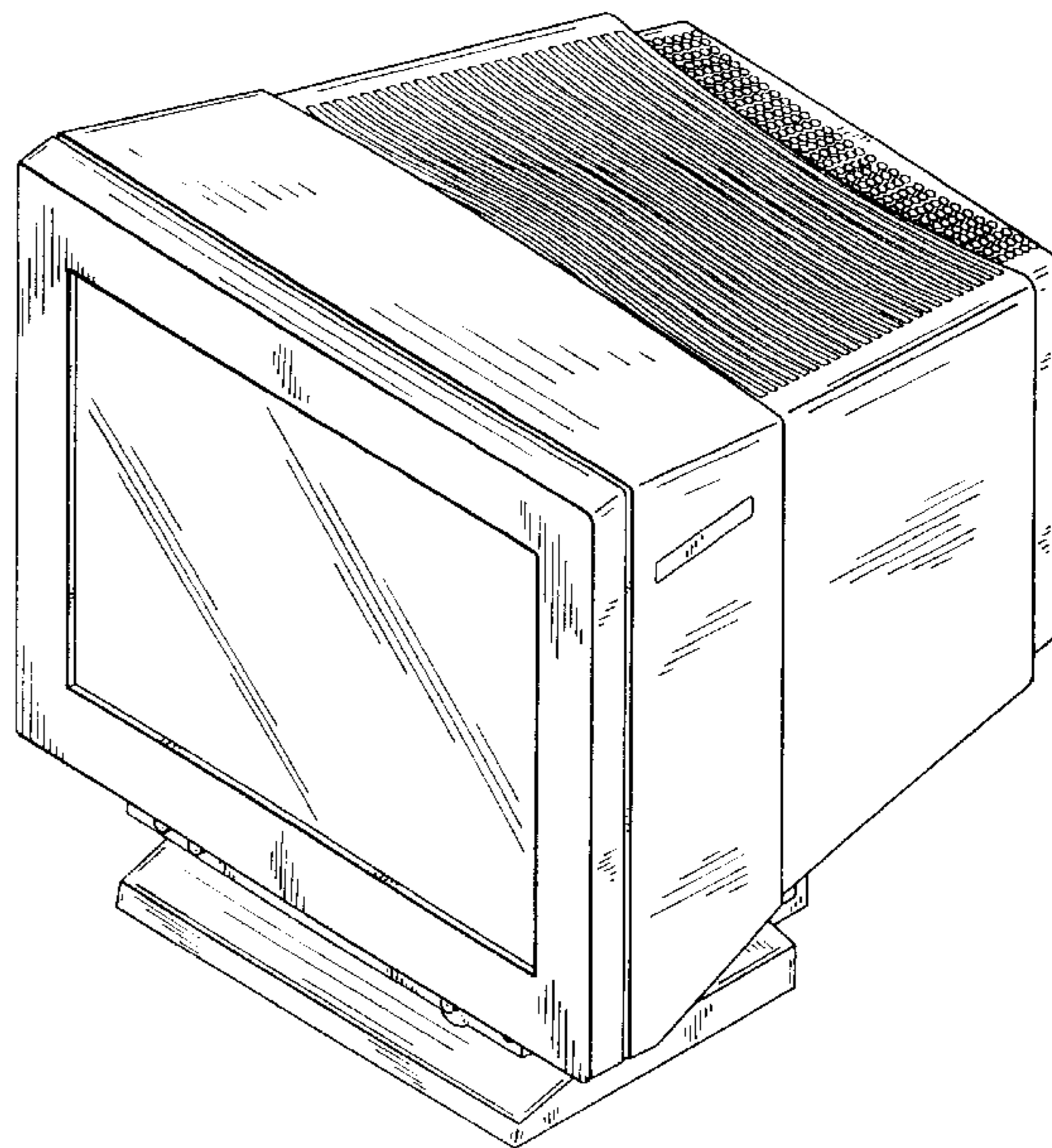
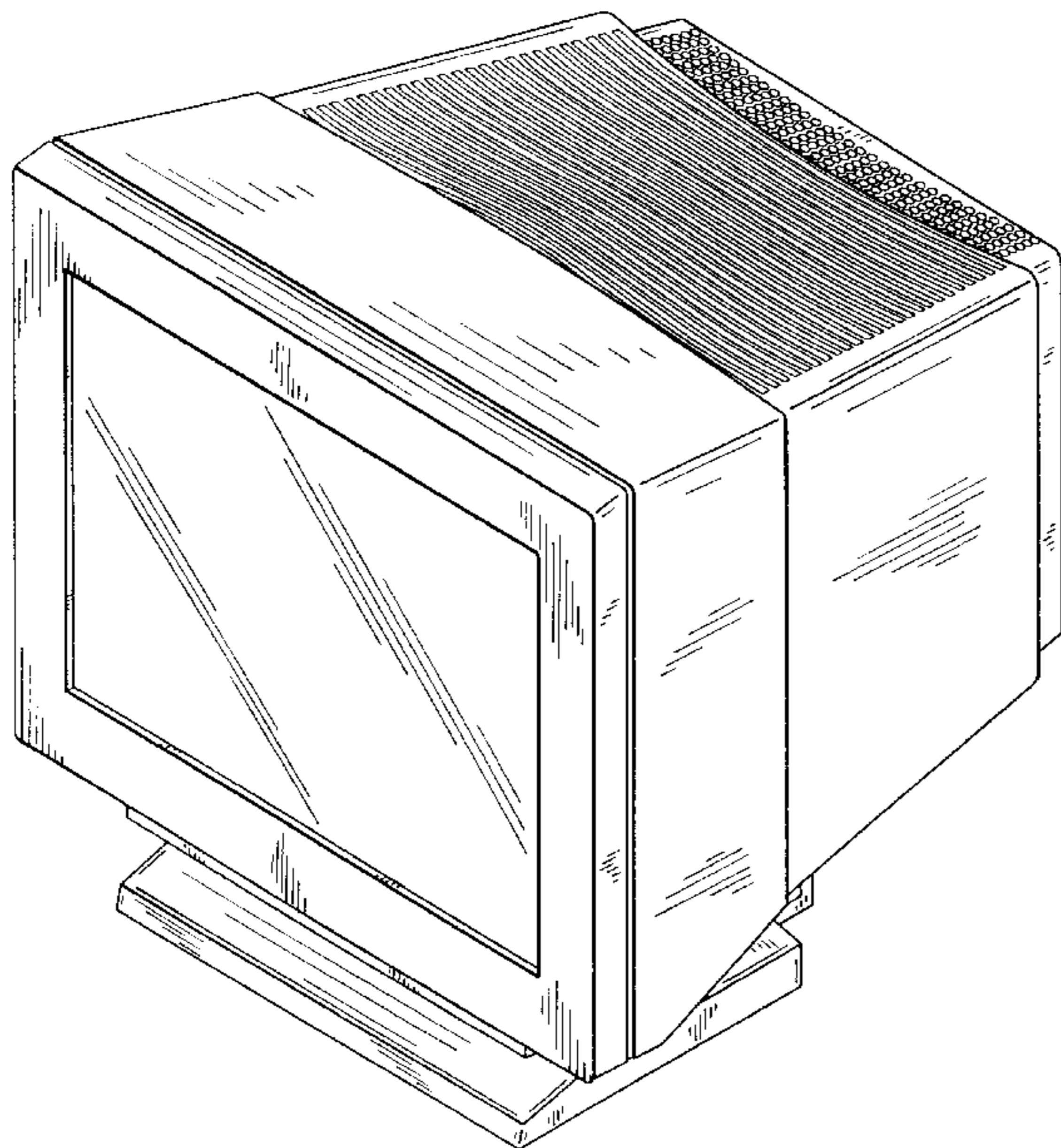

FIG. 1

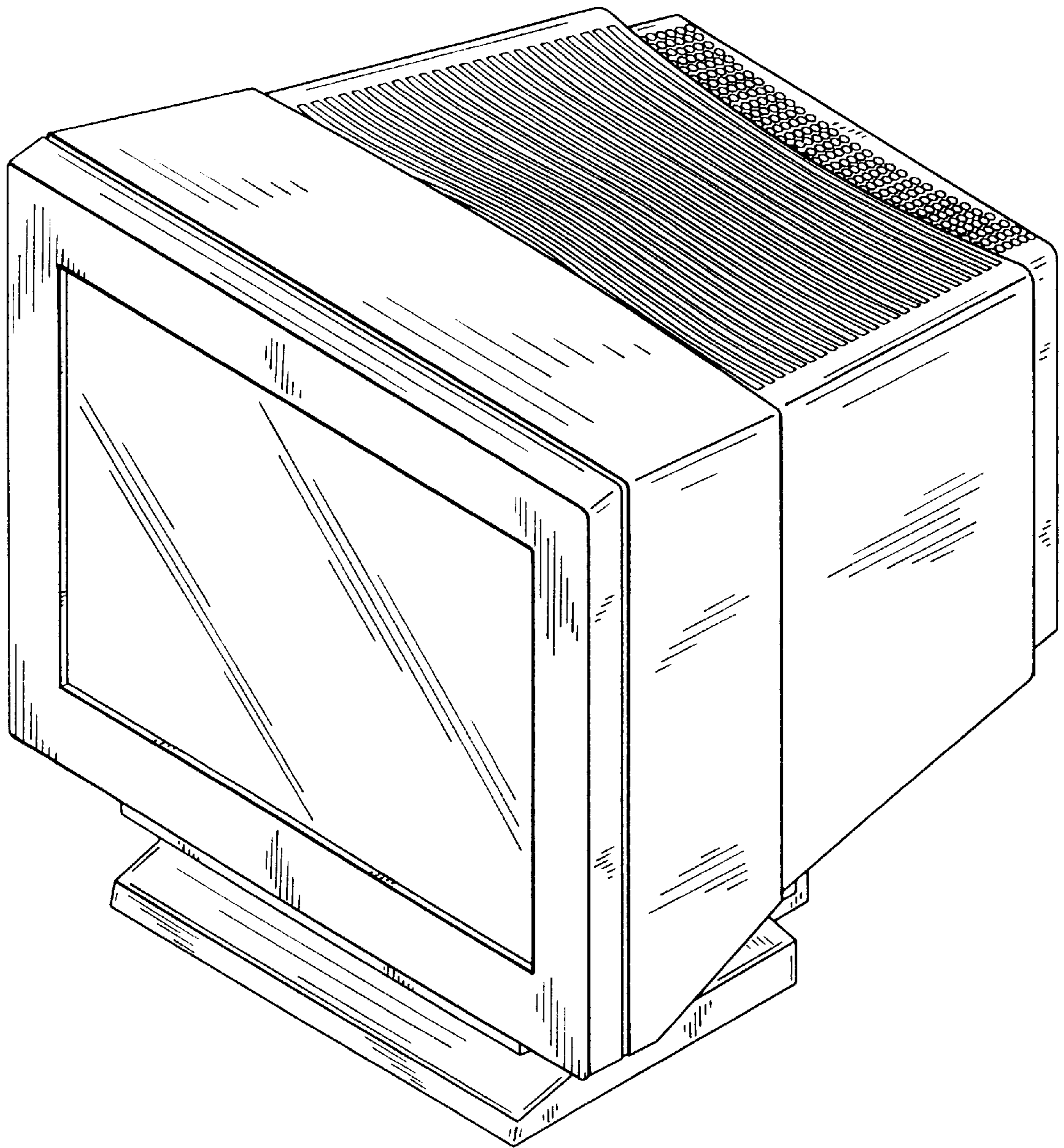

FIG. 2

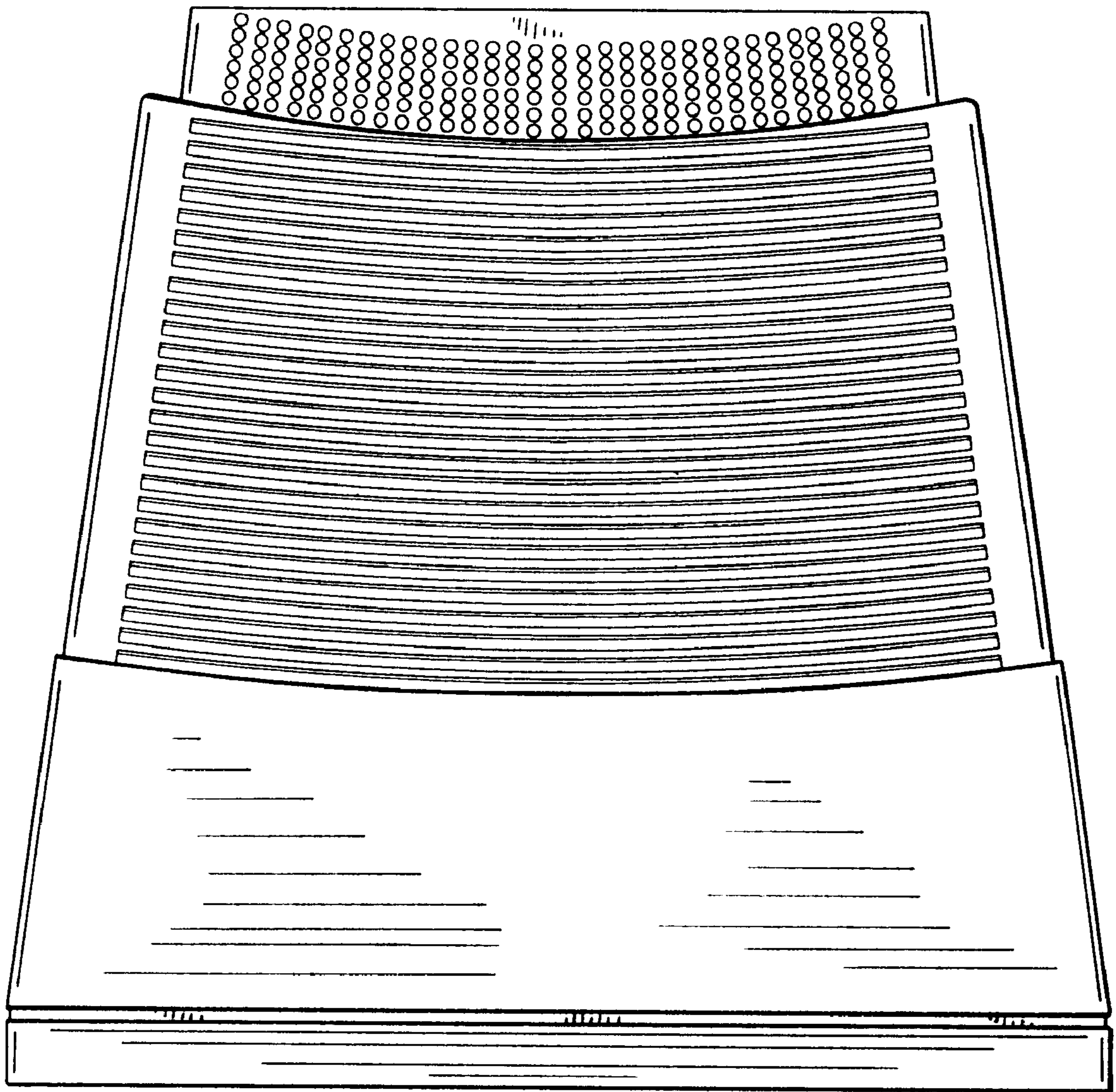

FIG. 4

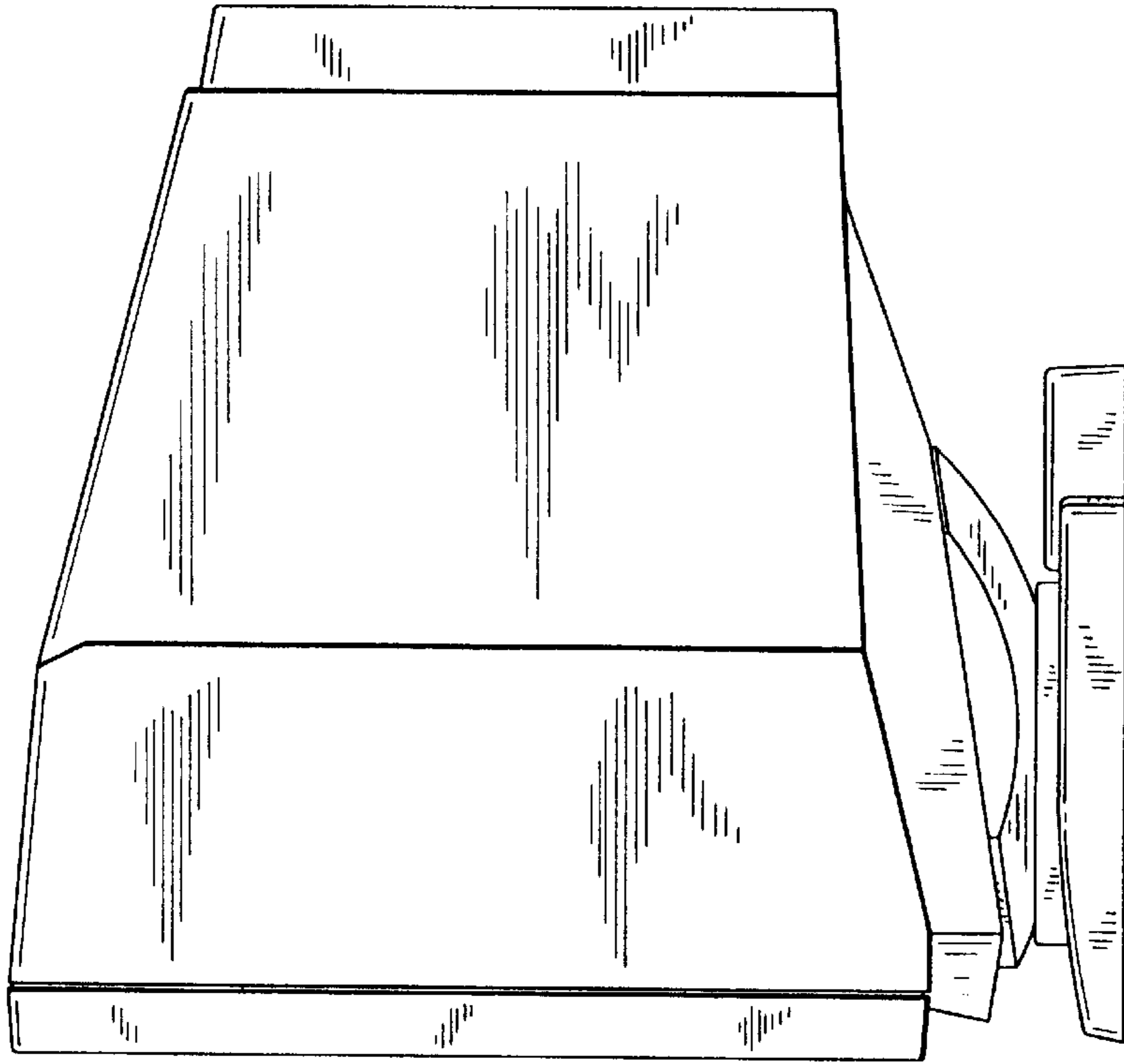

FIG. 3

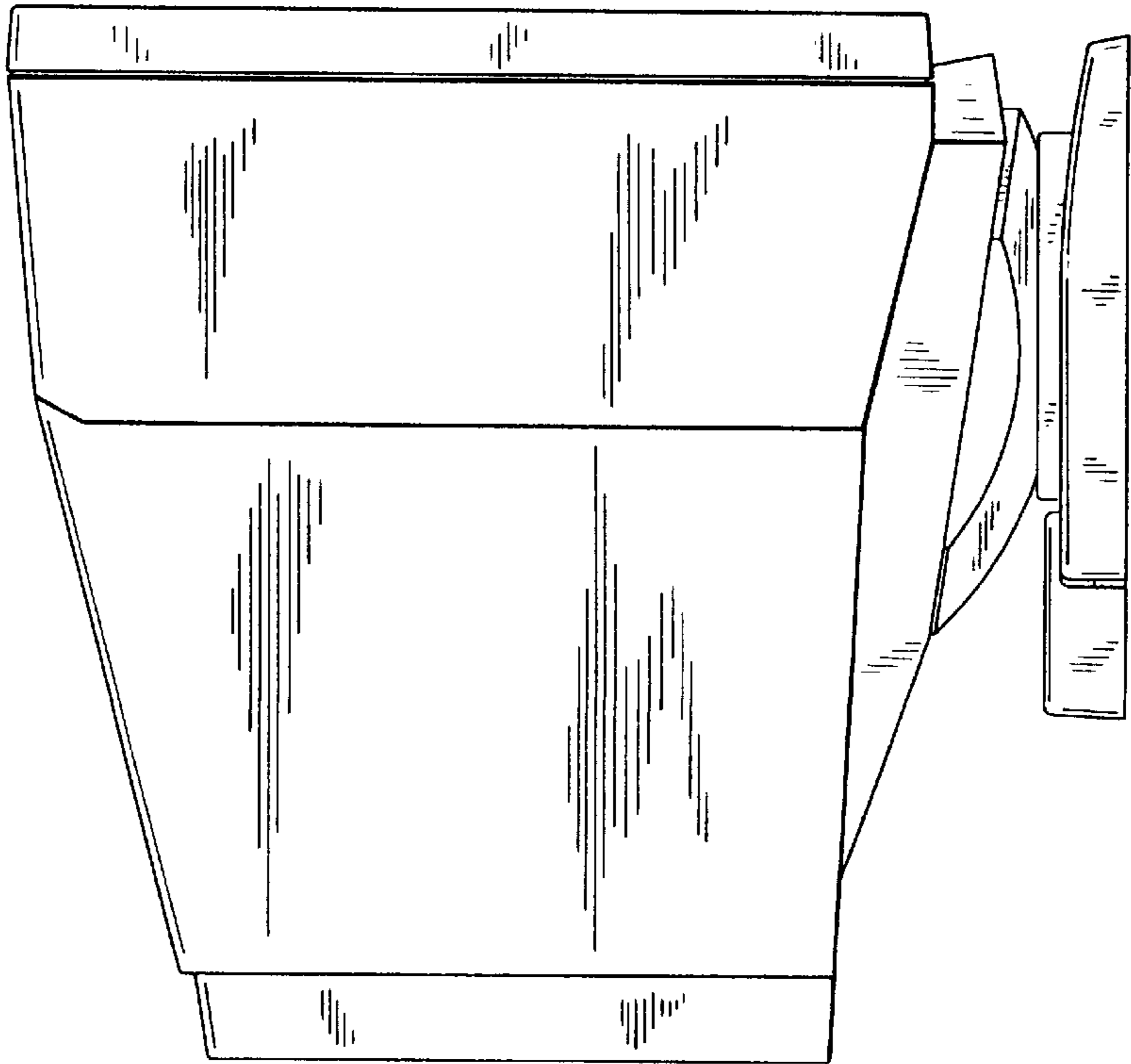

FIG. 5

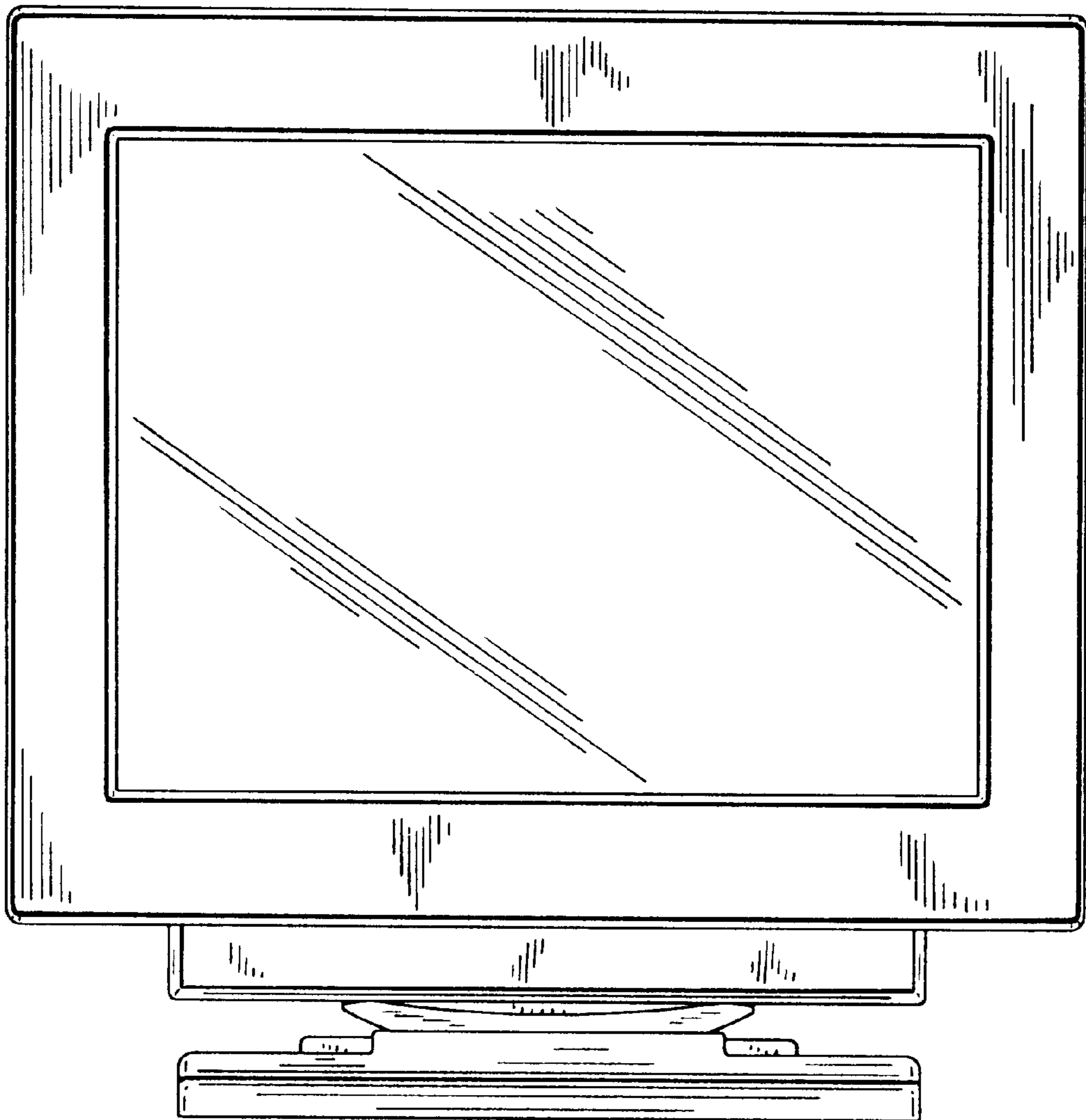

FIG.6

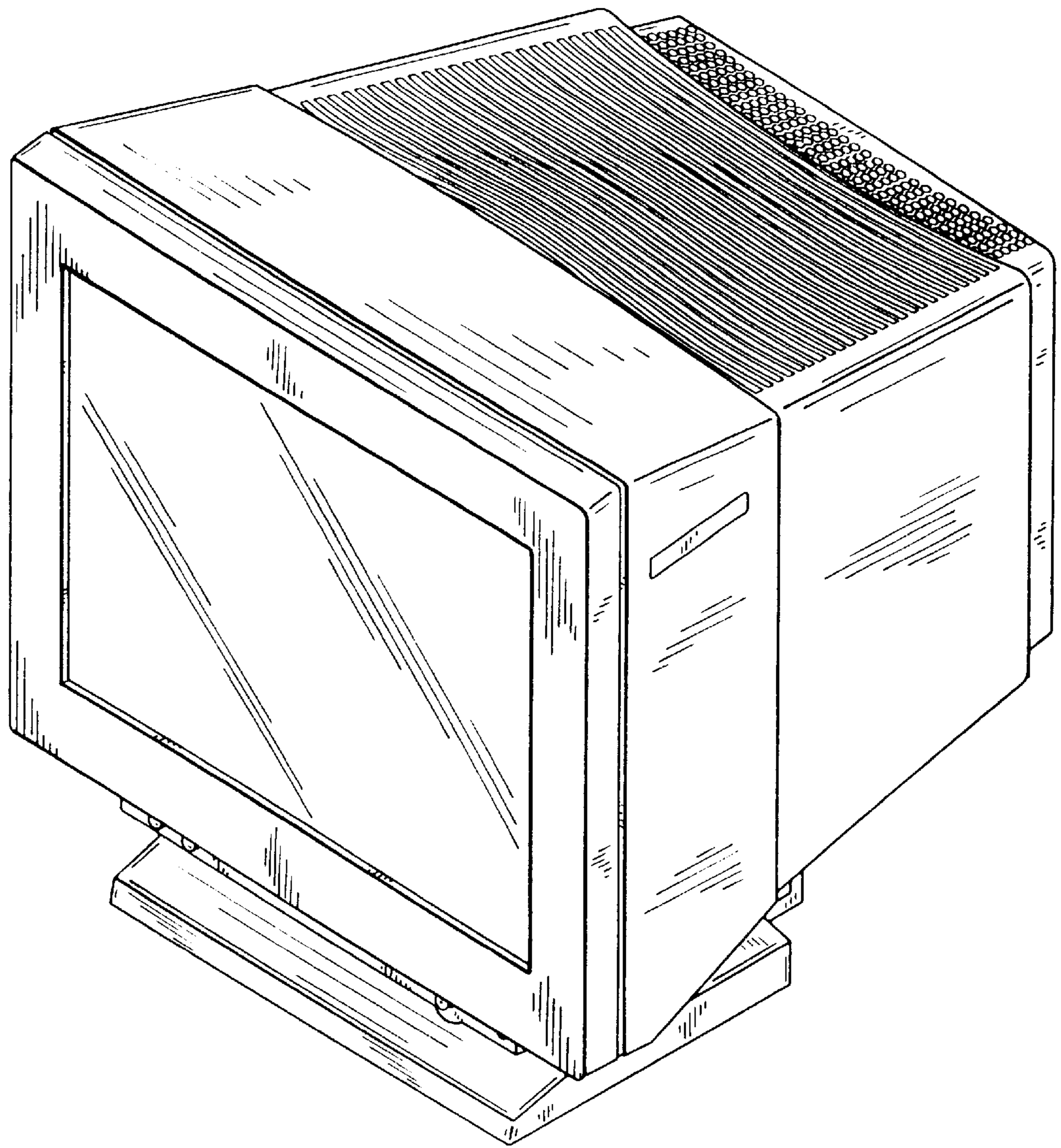

FIG. 7

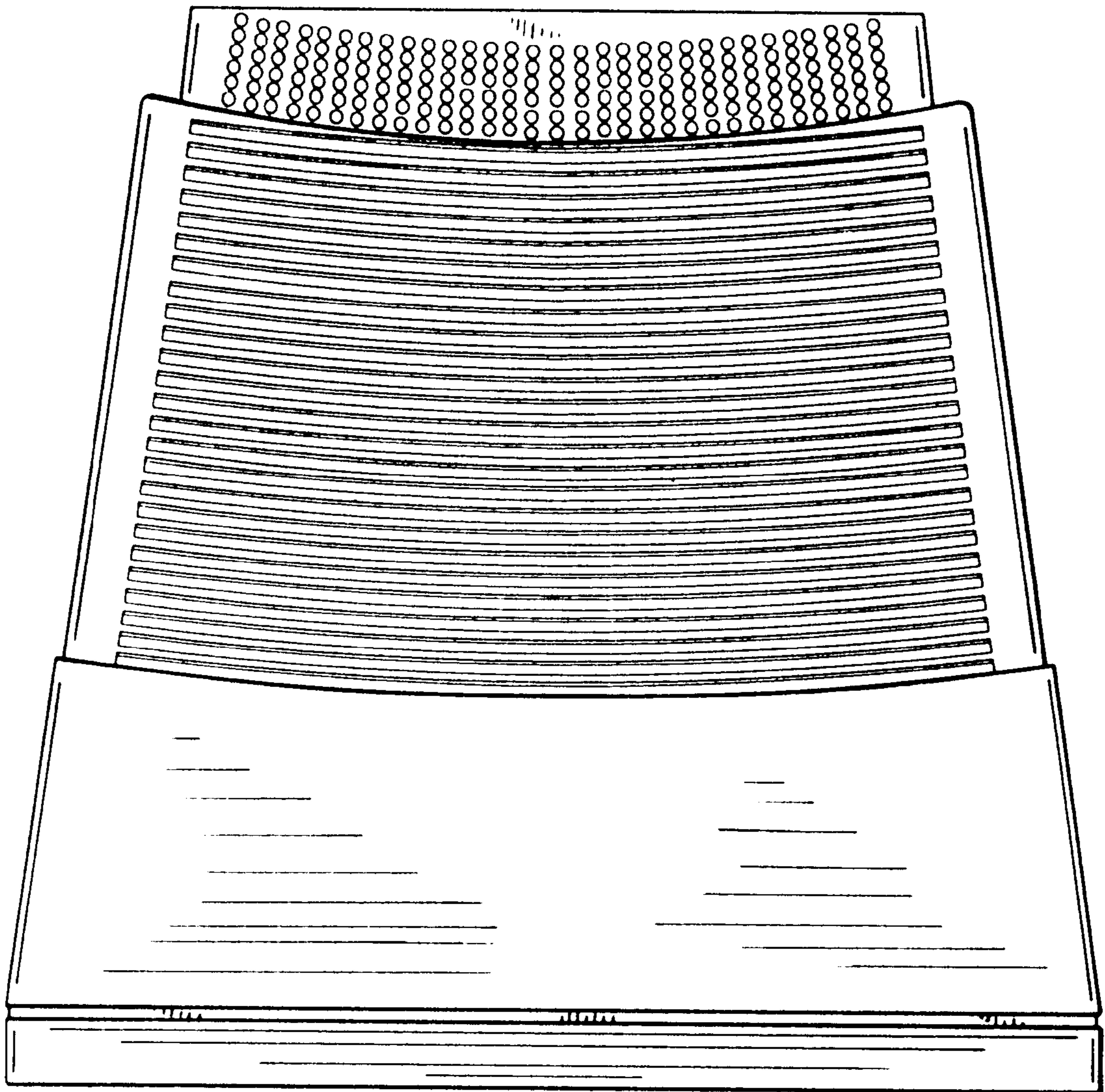

FIG. 8

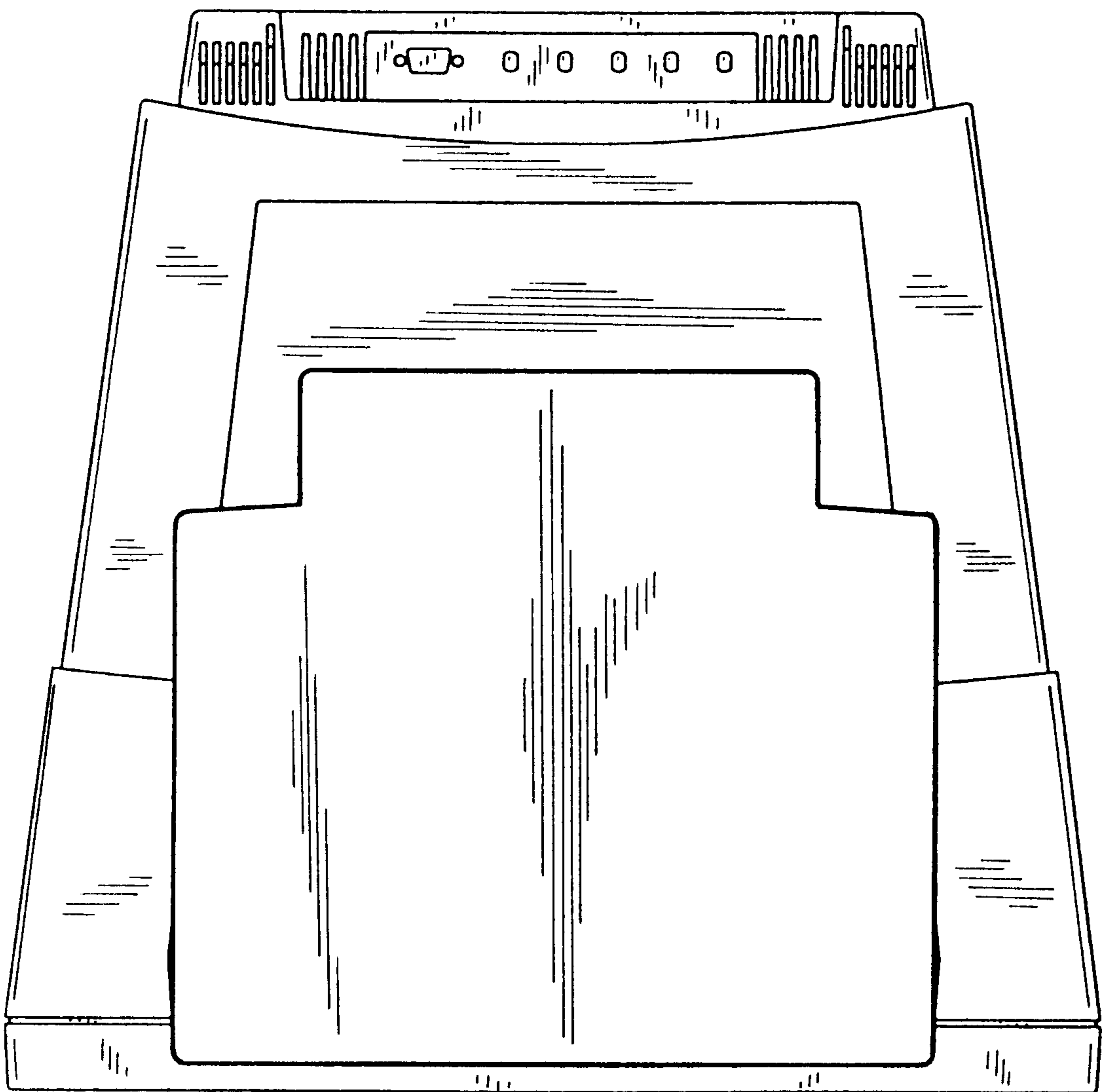

FIG. 10

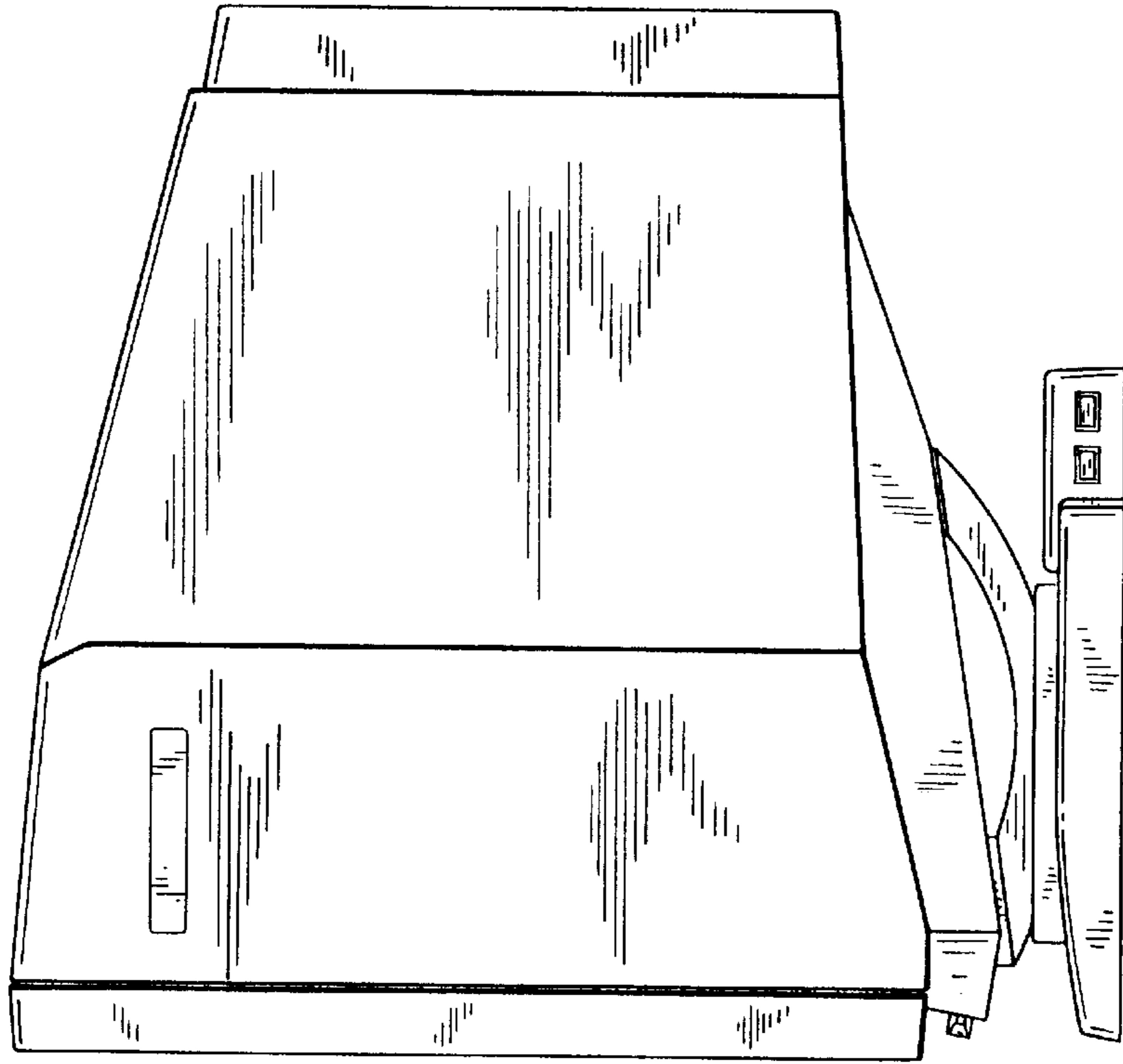

FIG. 9

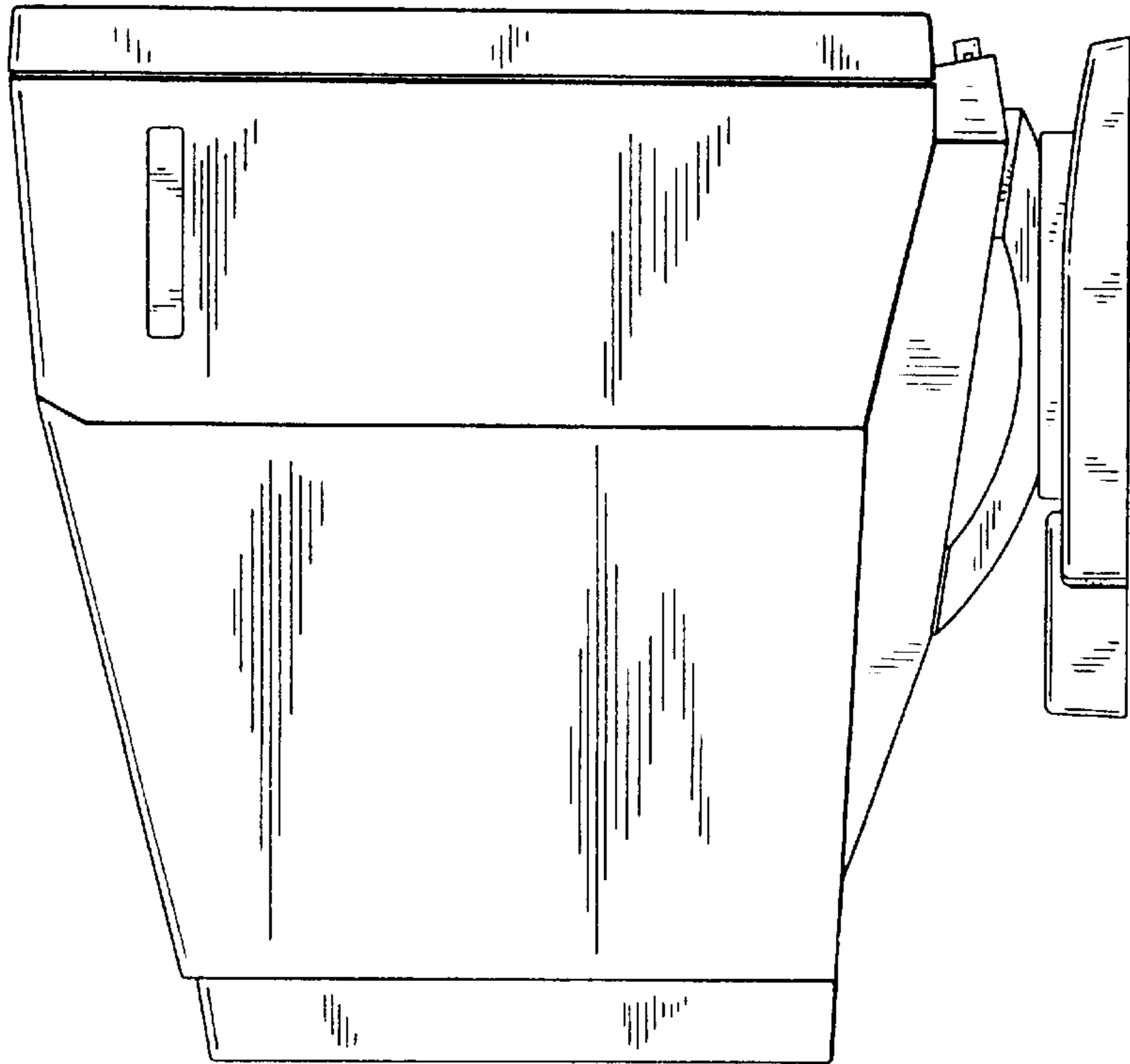

FIG. 11

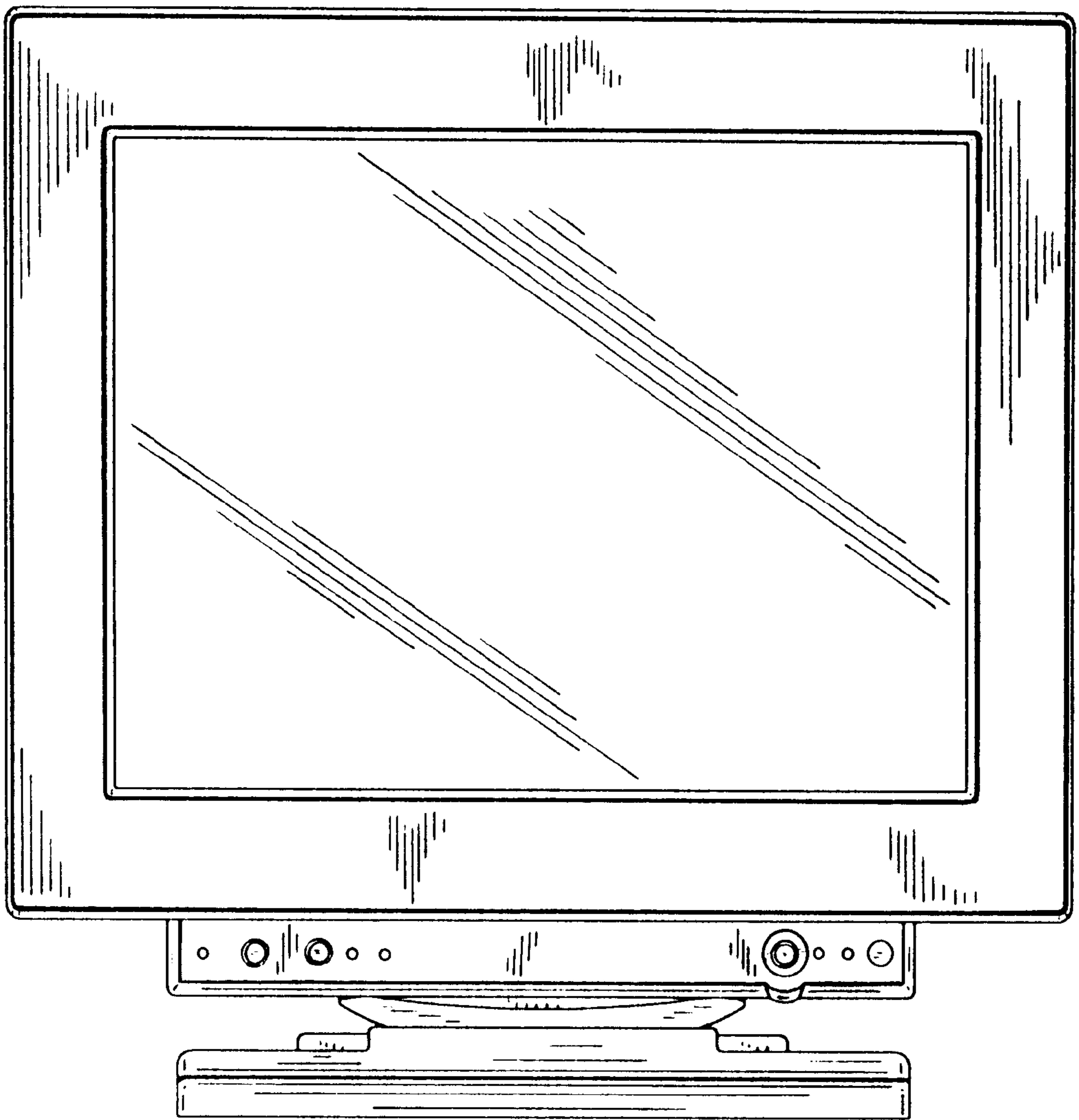

FIG. 12

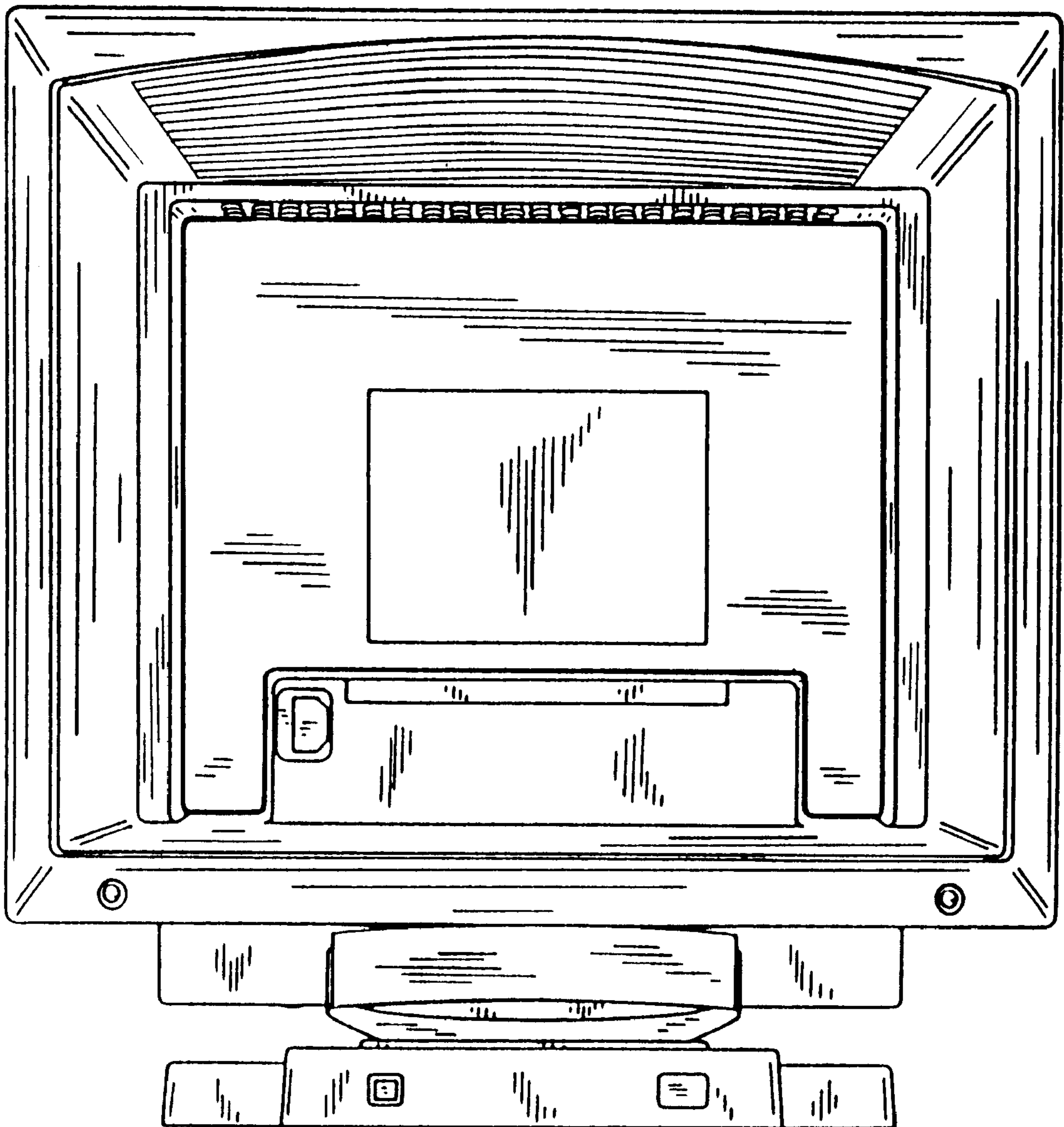

FIG. 13

