



US00D413227S

United States Patent [19]

Alonge et al.

[11] Patent Number: **Des. 413,227**

[45] Date of Patent: **** Aug. 31, 1999**

[54] **MINI FOOD PROCESSOR**

[75] Inventors: **Barbara Alonge**, North Merrick, N.Y.;
David Sabin, Lake Forest, Ill.

[73] Assignee: **Salton/Maxim Housewares, Inc.**

[**] Term: **14 Years**

[21] Appl. No.: **29/093,342**

[22] Filed: **Sep. 9, 1998**

[51] **LOC (6) Cl.** **31-00**

[52] **U.S. Cl.** **D7/384**

[58] **Field of Search** D7/376-386; 241/37.5,
241/92, 93, 282.1, 282.2

[56] **References Cited**

U.S. PATENT DOCUMENTS

- D. 251,407 3/1979 Tsuji et al. D7/384
- D. 282,620 2/1986 Cavalli D7/384

- D. 345,079 3/1994 Johnson D7/384
- D. 366,984 2/1996 Hsu D7/376
- D. 392,150 3/1998 Tanaka et al. D7/384
- 4,799,626 6/1989 Hickel et al. 241/37.5

Primary Examiner—Caron D. Veynar
Attorney, Agent, or Firm—Jerry A. Schulman

[57] **CLAIM**

The ornamental design for a mini-food processor, as shown and described.

DESCRIPTION

FIG. 1 is a front elevational view of the present invention; FIG. 2 is a right lateral elevational view thereof; FIG. 3 is a left lateral elevational view thereof; FIG. 4 is a top plan view thereof; FIG. 5 is a bottom plan view thereof; FIG. 6 is a rear elevational view thereof; and, FIG. 7 is a perspective view thereof.

1 Claim, 3 Drawing Sheets

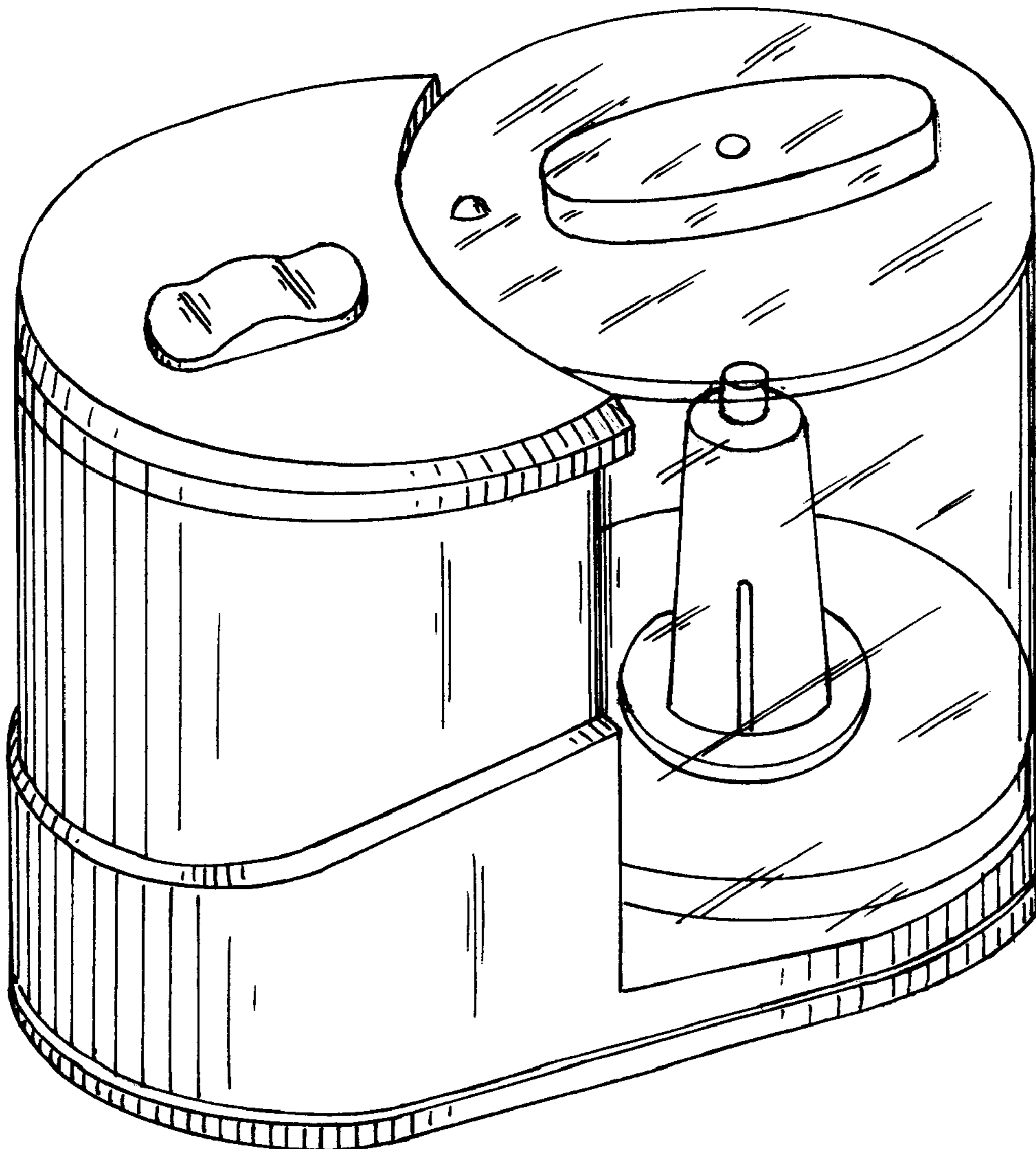

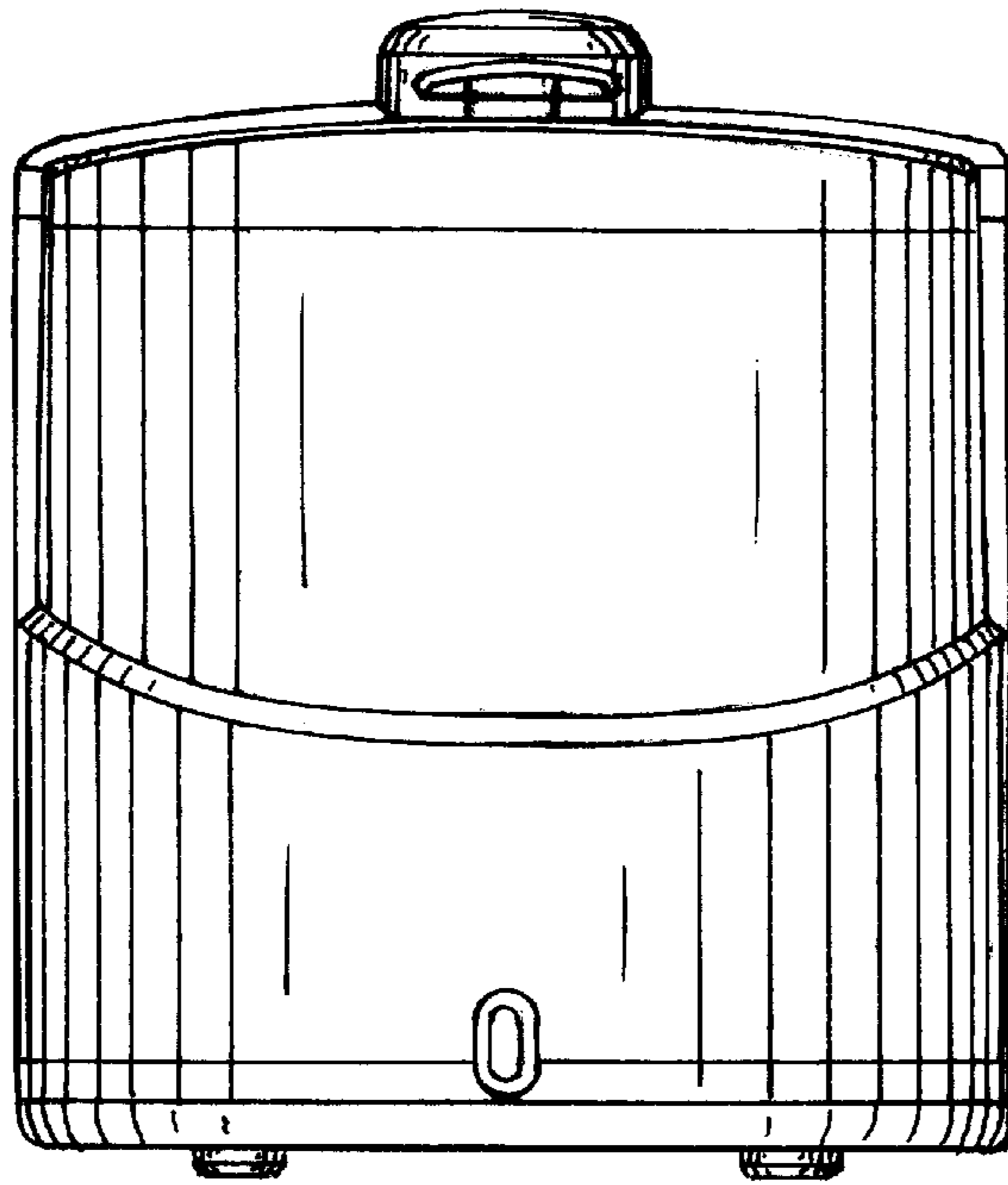

FIG. 1

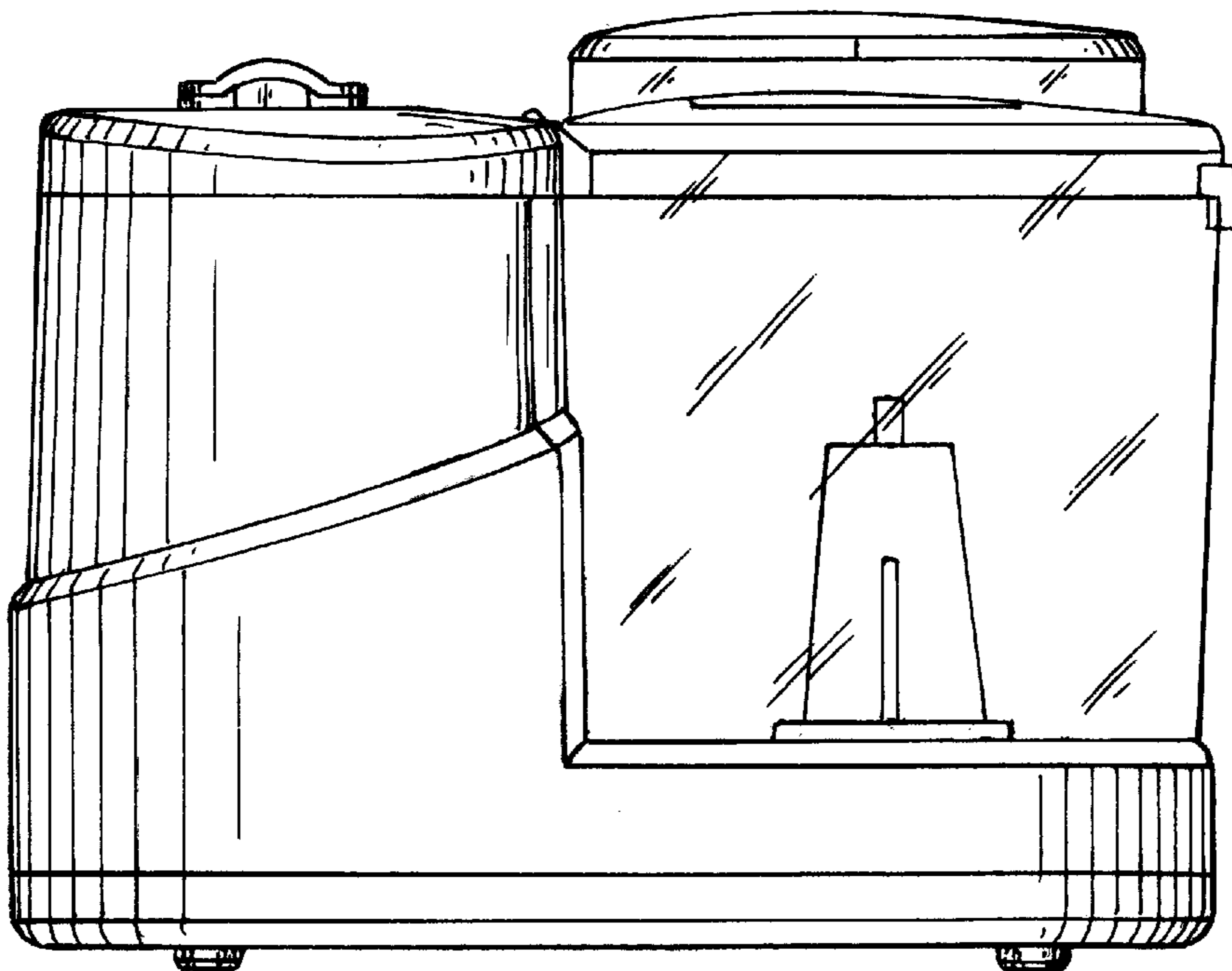

FIG. 2

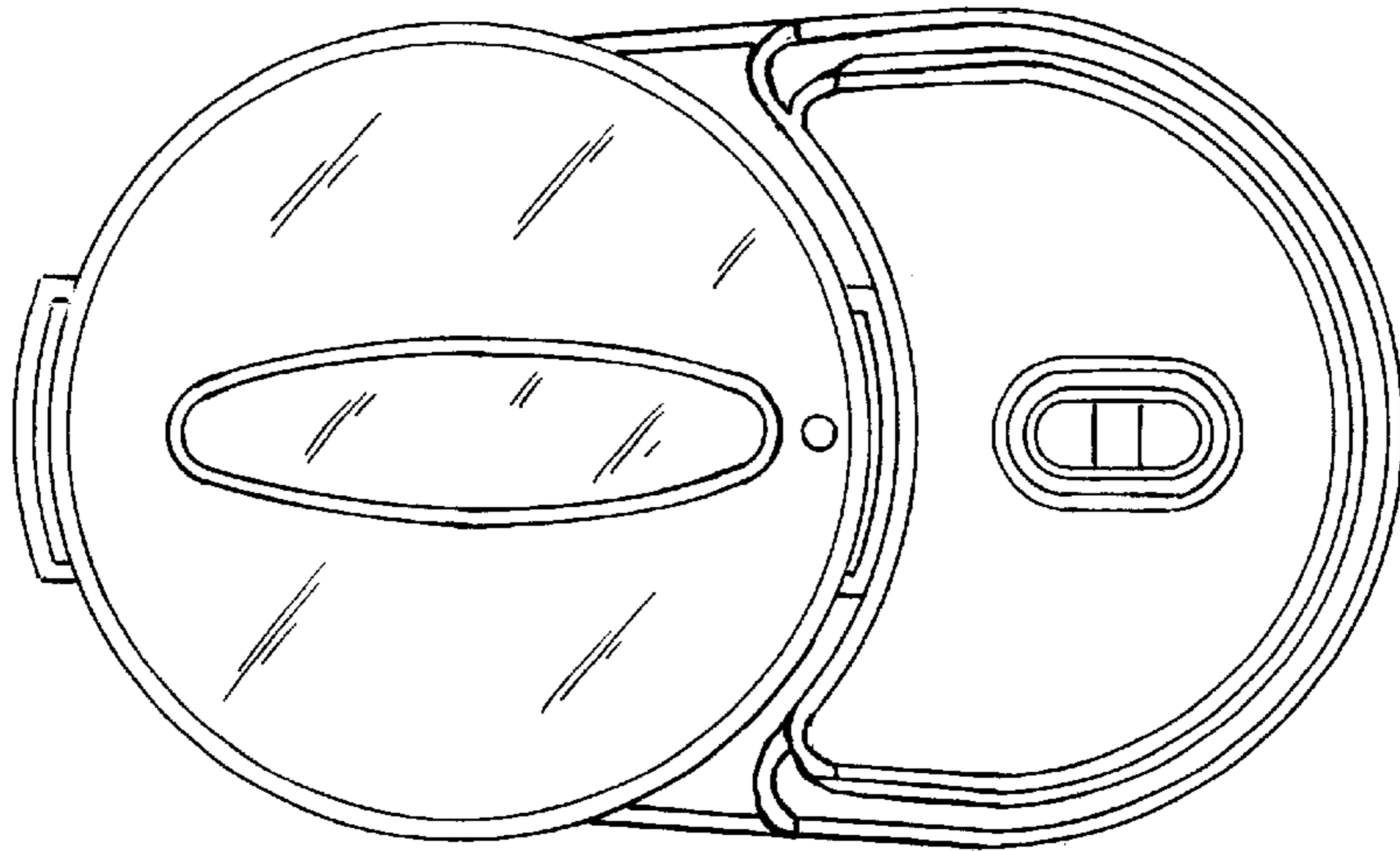

FIG. 4

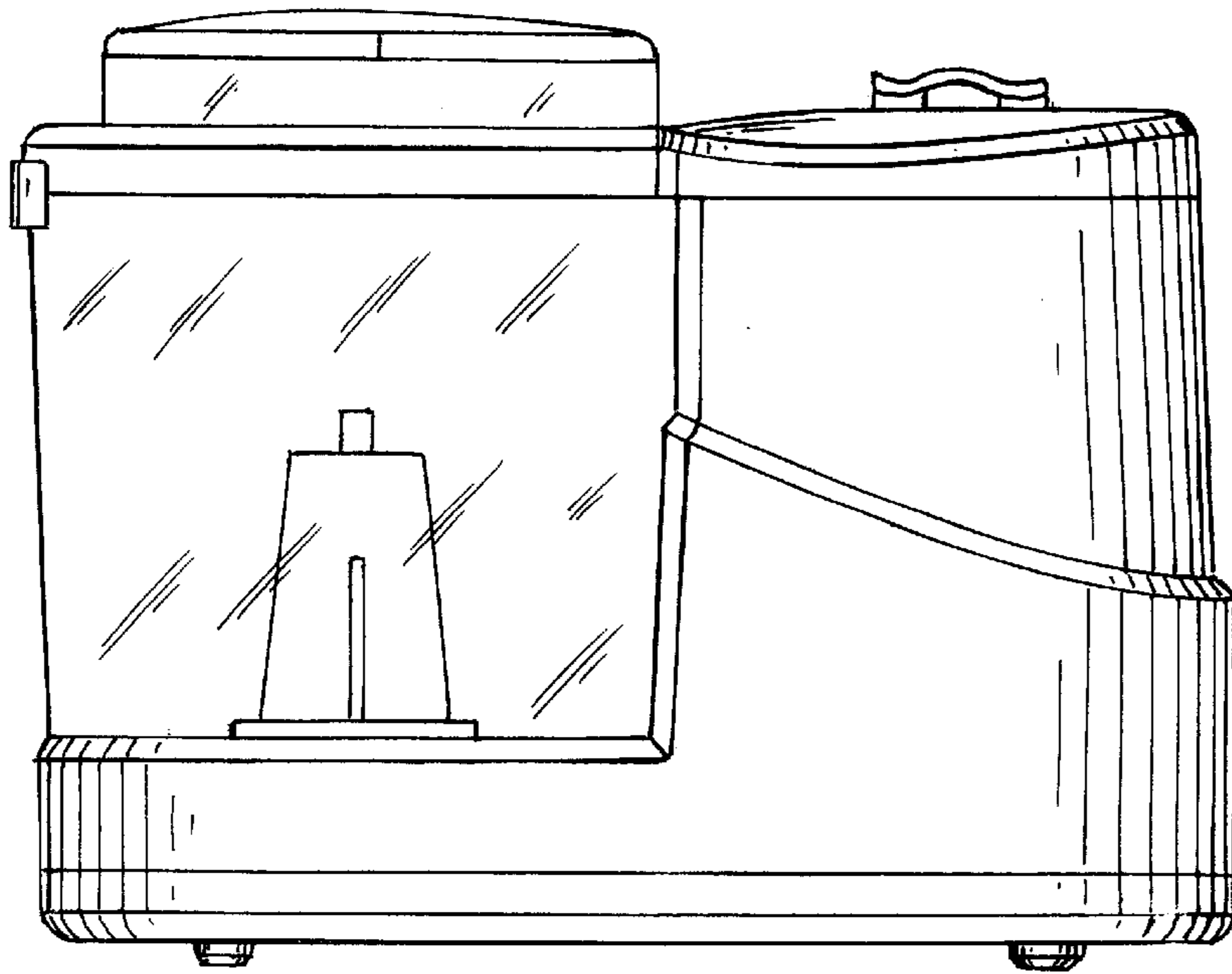

FIG. 3

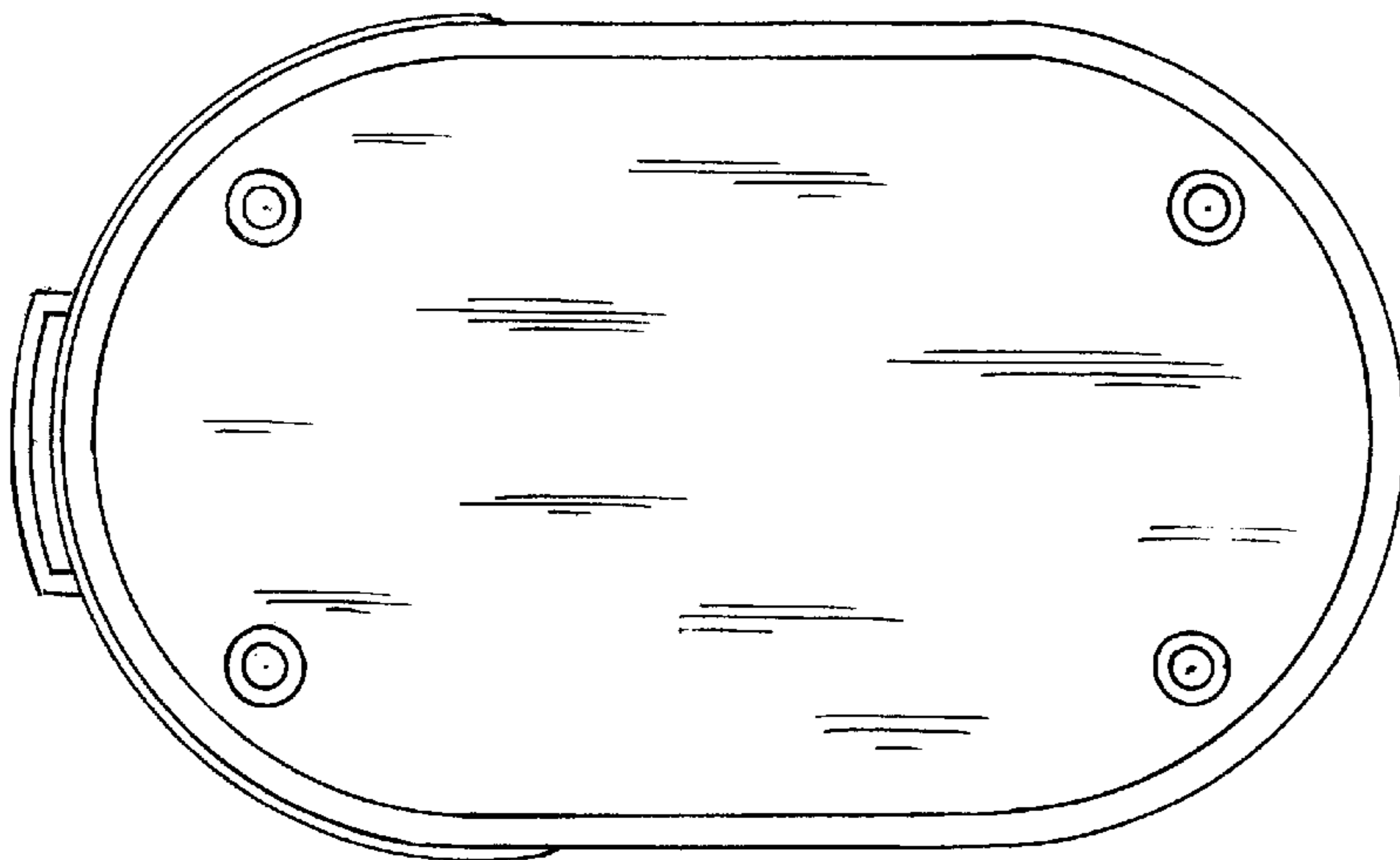

FIG. 5

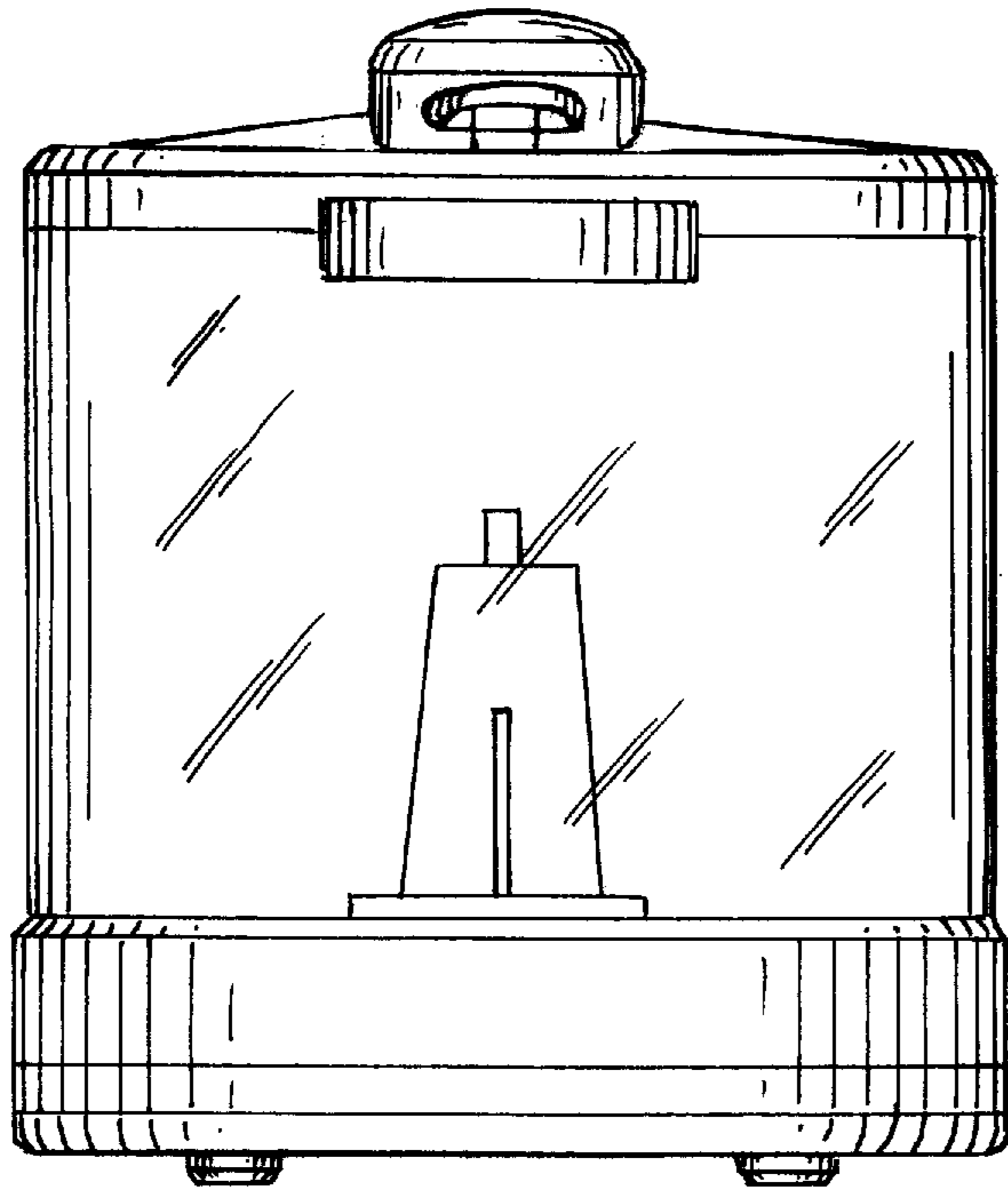

FIG. 6

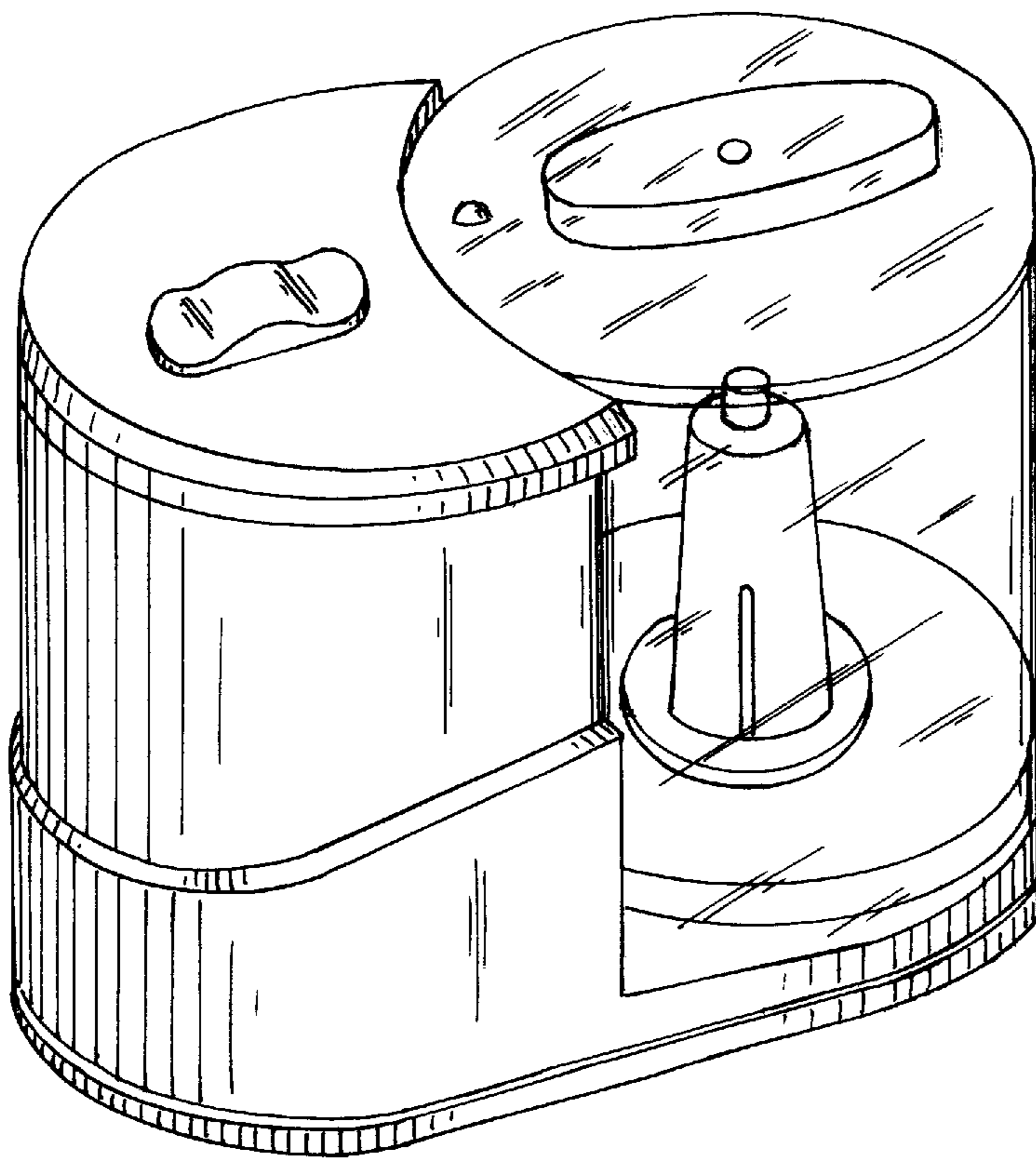

FIG. 7