



US00D413190S

United States Patent [19]
Catanach et al.

[11] **Patent Number: Des. 413,190**

[45] **Date of Patent: ** Aug. 24, 1999**

[54] **TROLLEY BUMPER**

3,810,428 5/1974 Klamp 104/172.2
3,902,430 9/1975 Ott et al. 104/178
4,058,064 11/1977 Wilder et al. .

[75] Inventors: **Wallace Catanach**, Northville; **Chris Ariss**, Lincoln Park, both of Mich.

[73] Assignee: **Jervis B. Webb Company**, Farmington Hills, Mich.

Primary Examiner—Alan P. Douglas
Assistant Examiner—Cynthia E. Ramirez
Attorney, Agent, or Firm—Dickinson Wright PLLC

[**] Term: **14 Years**

[57] **CLAIM**

[21] Appl. No.: **29/081,811**

The ornamental design of a trolley bumper, as shown and described.

[22] Filed: **Sep. 30, 1997**

DESCRIPTION

[51] **LOC (6) Cl.** **12-05**

FIG. 1 is a perspective view of a trolley bumper according to the present invention;

[52] **U.S. Cl.** **D34/28**

FIG. 2 is a right side elevational view of the trolley bumper shown in FIG. 1;

[58] **Field of Search** D34/28, 35; 104/172.2, 104/178, 254; 213/220, 221, 222, 40 R

FIG. 3 is a left side elevational view of the trolley bumper of FIG. 1;

[56] **References Cited**

U.S. PATENT DOCUMENTS

| | | | | |
|-----------|---------|-------------------|-------|-----------|
| 2,001,855 | 5/1935 | Spencer | | 213/220 |
| 2,164,859 | 7/1939 | Willoughby | . | |
| 3,011,457 | 12/1961 | Peras | . | |
| 3,083,650 | 4/1963 | Peras | . | |
| 3,294,254 | 12/1966 | De Ment | . | |
| 3,451,353 | 6/1969 | Bishop | | 104/172.2 |
| 3,467,023 | 9/1969 | Dodds et al. | . | |
| 3,675,587 | 7/1972 | Zetterlund et al. | | 104/172.2 |

FIG. 4 is a front elevational view of the trolley bumper of FIG. 1;

FIG. 5 is a rear elevational view of the trolley bumper of FIG. 1;

FIG. 6 is a top plan view of the trolley bumper of FIG. 1; and,

FIG. 7 is a bottom plan view of the trolley bumper of FIG. 1.

1 Claim, 2 Drawing Sheets

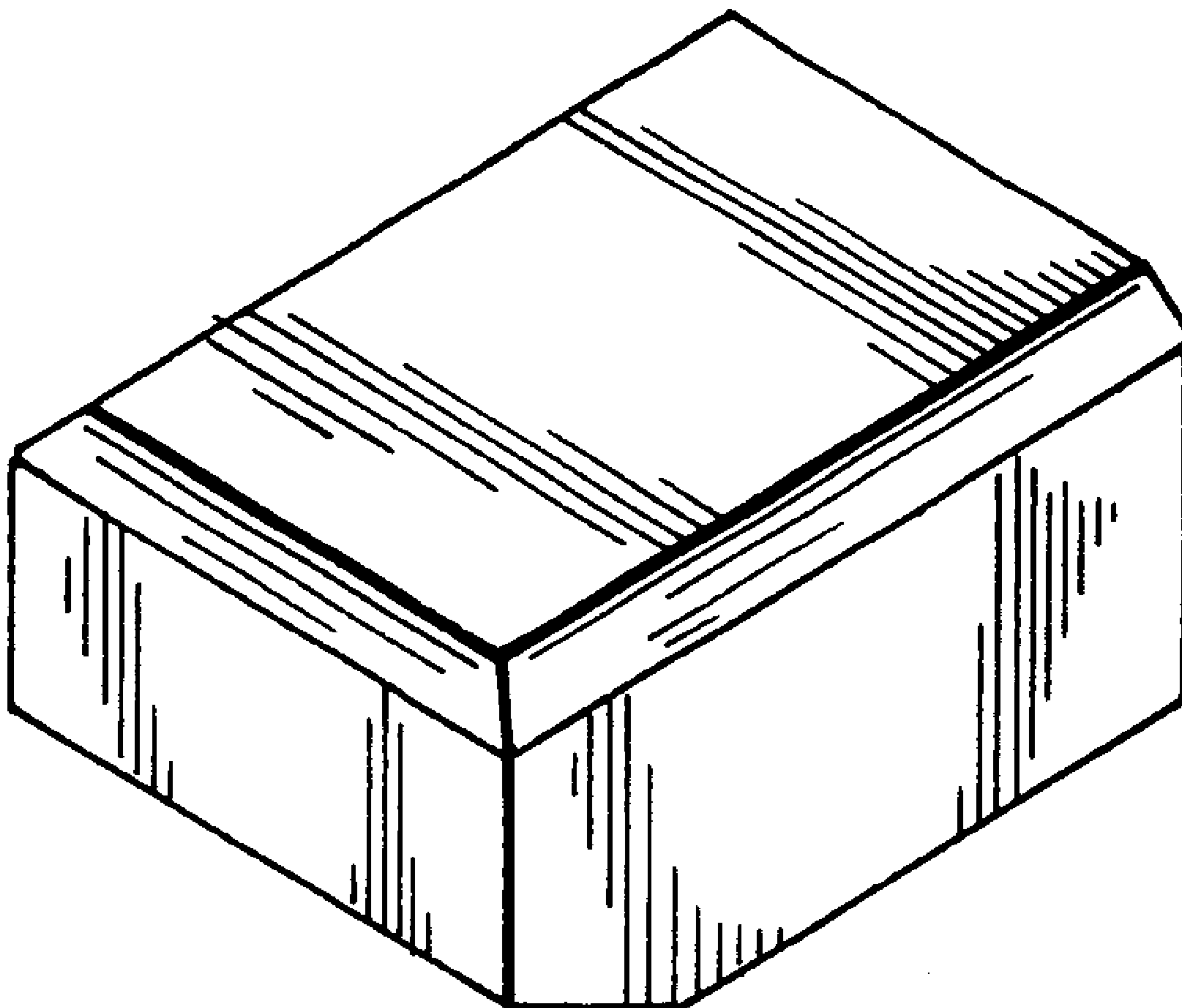

FIG. 1

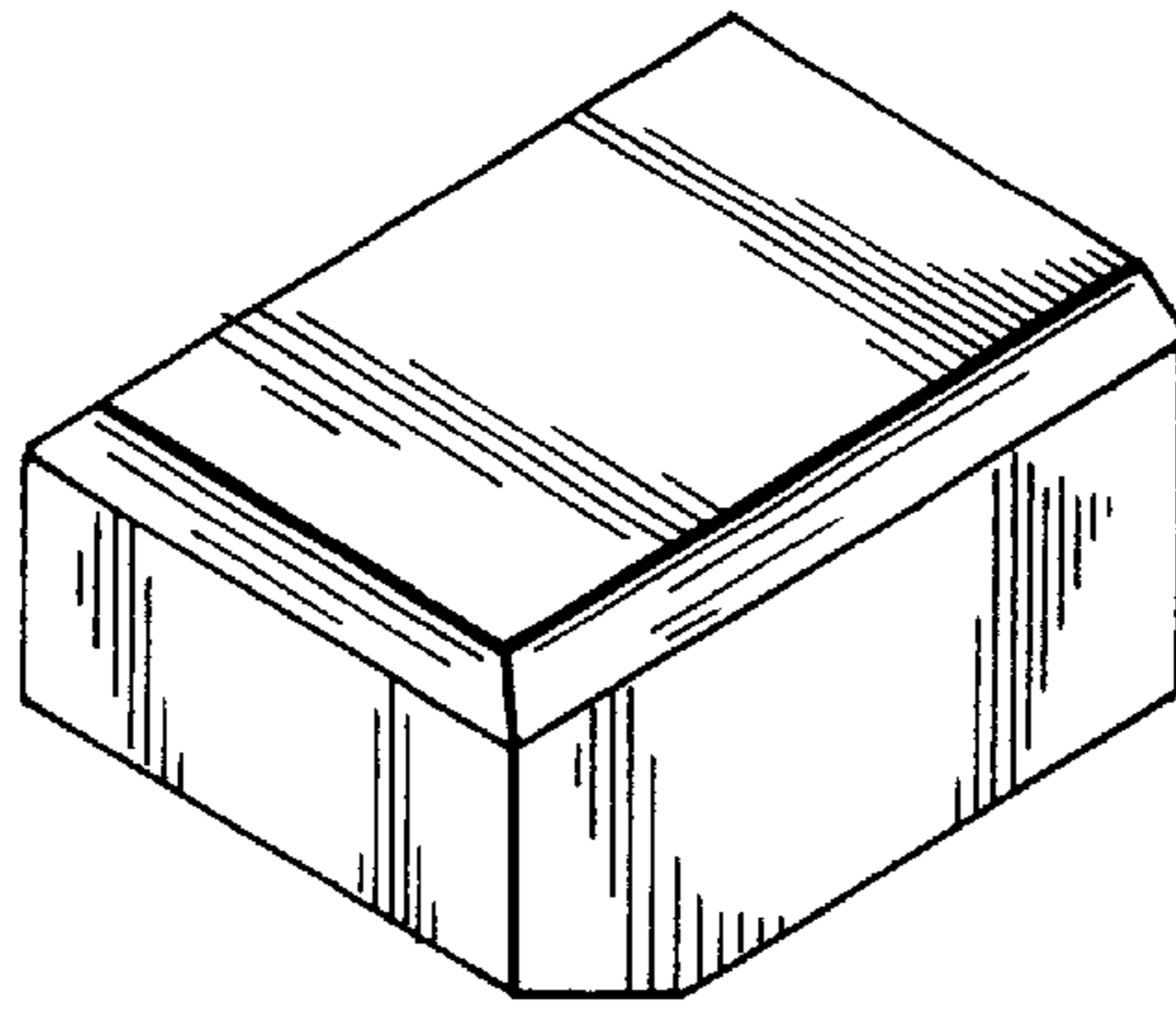

FIG. 2

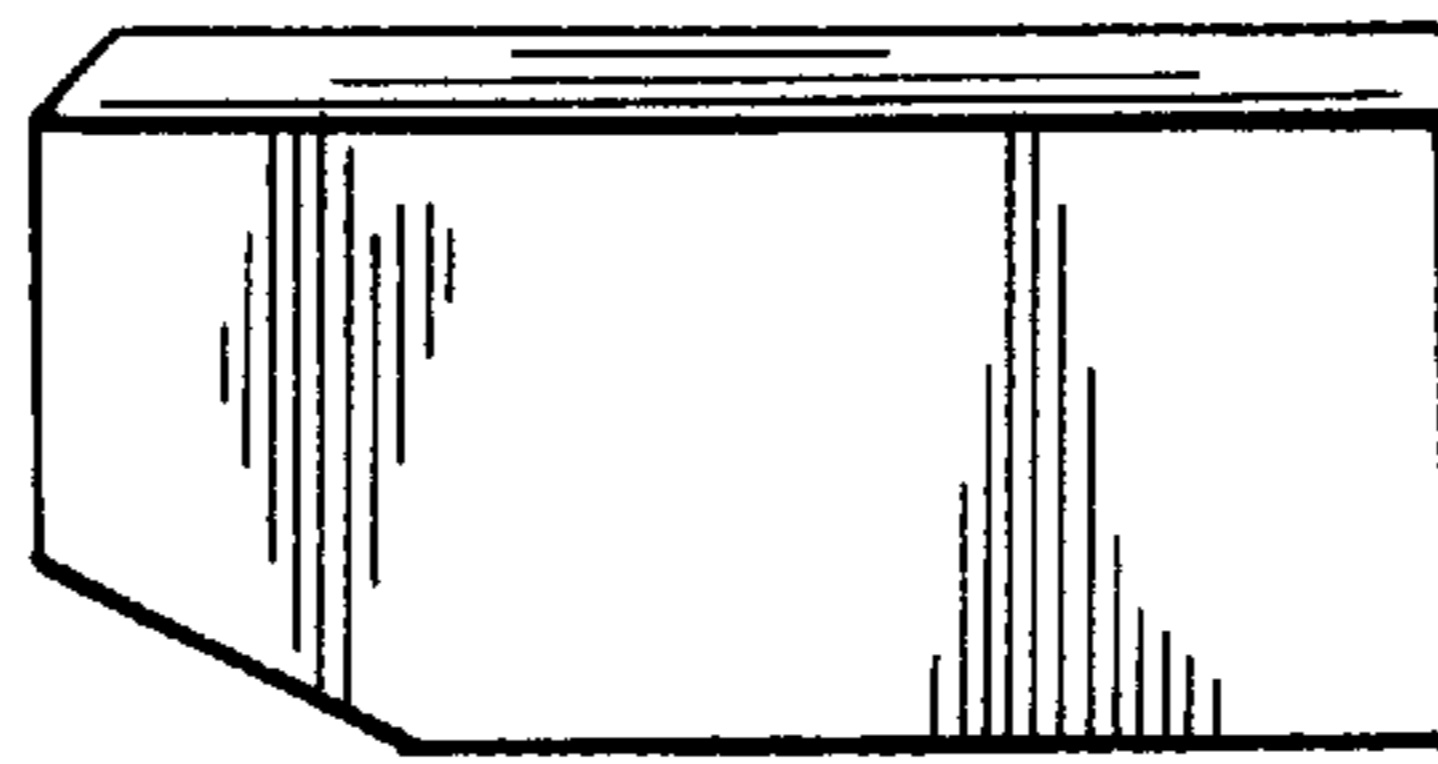

FIG. 3

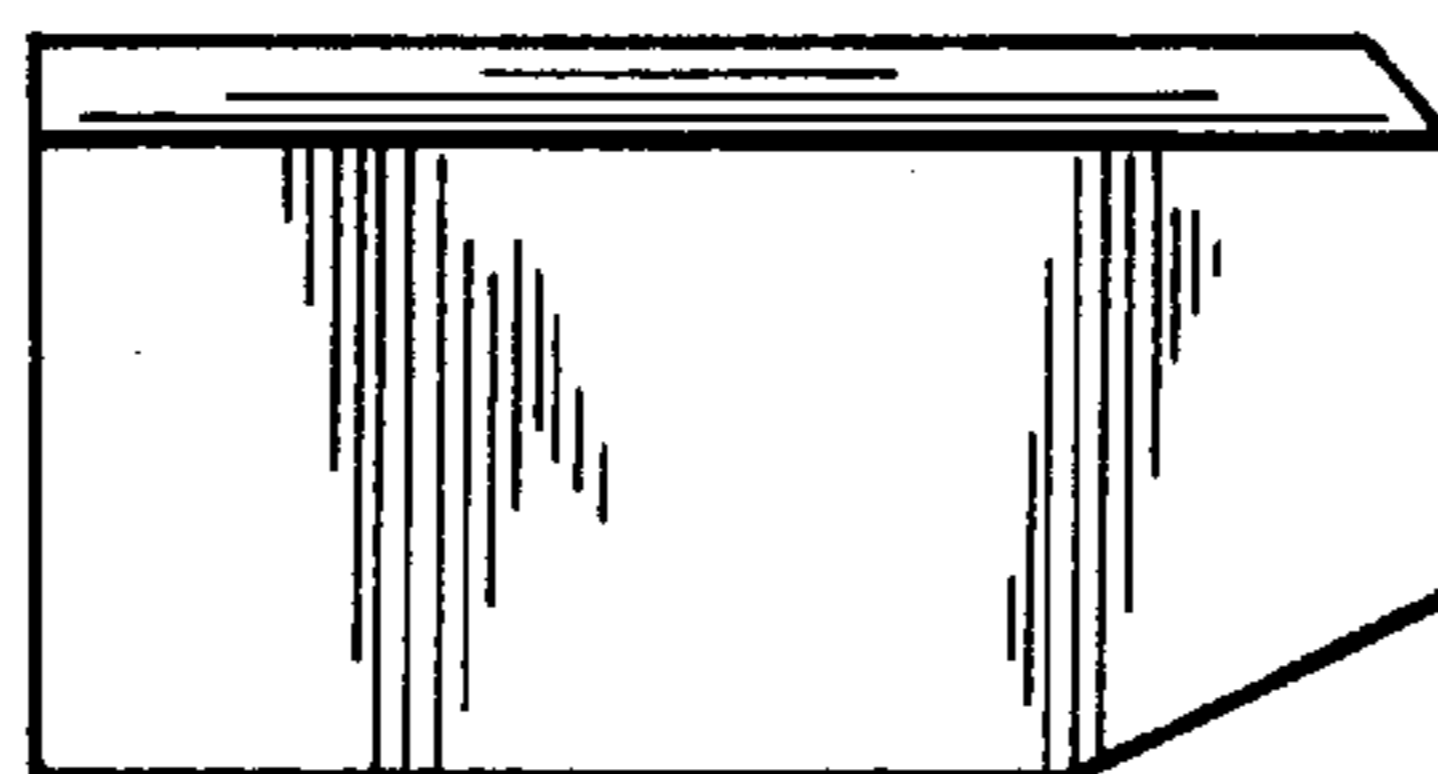

FIG. 4

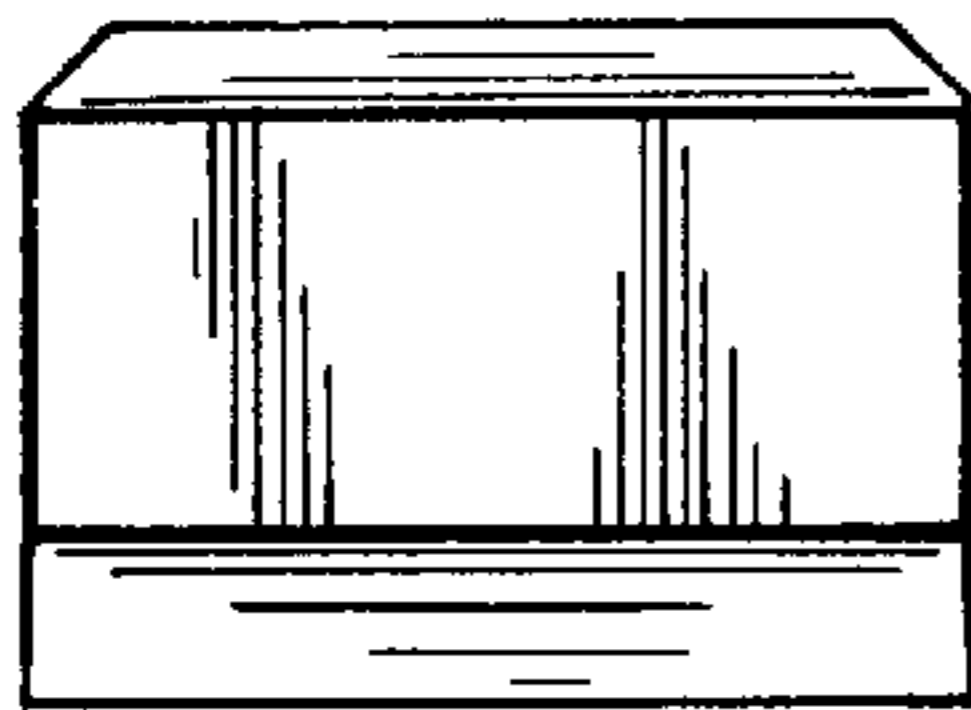

FIG. 5

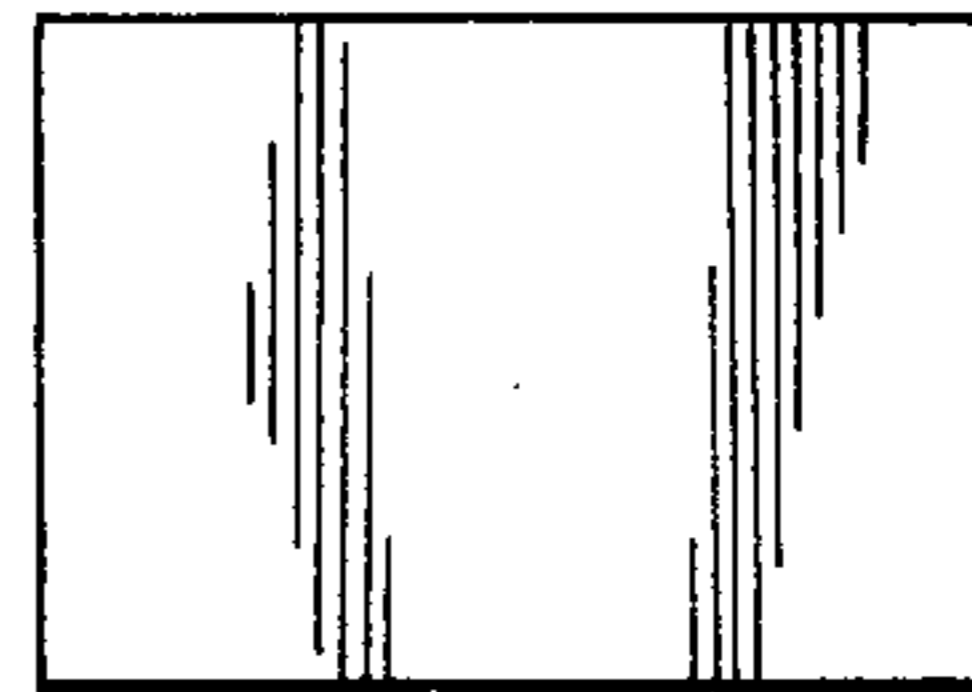

FIG. 6

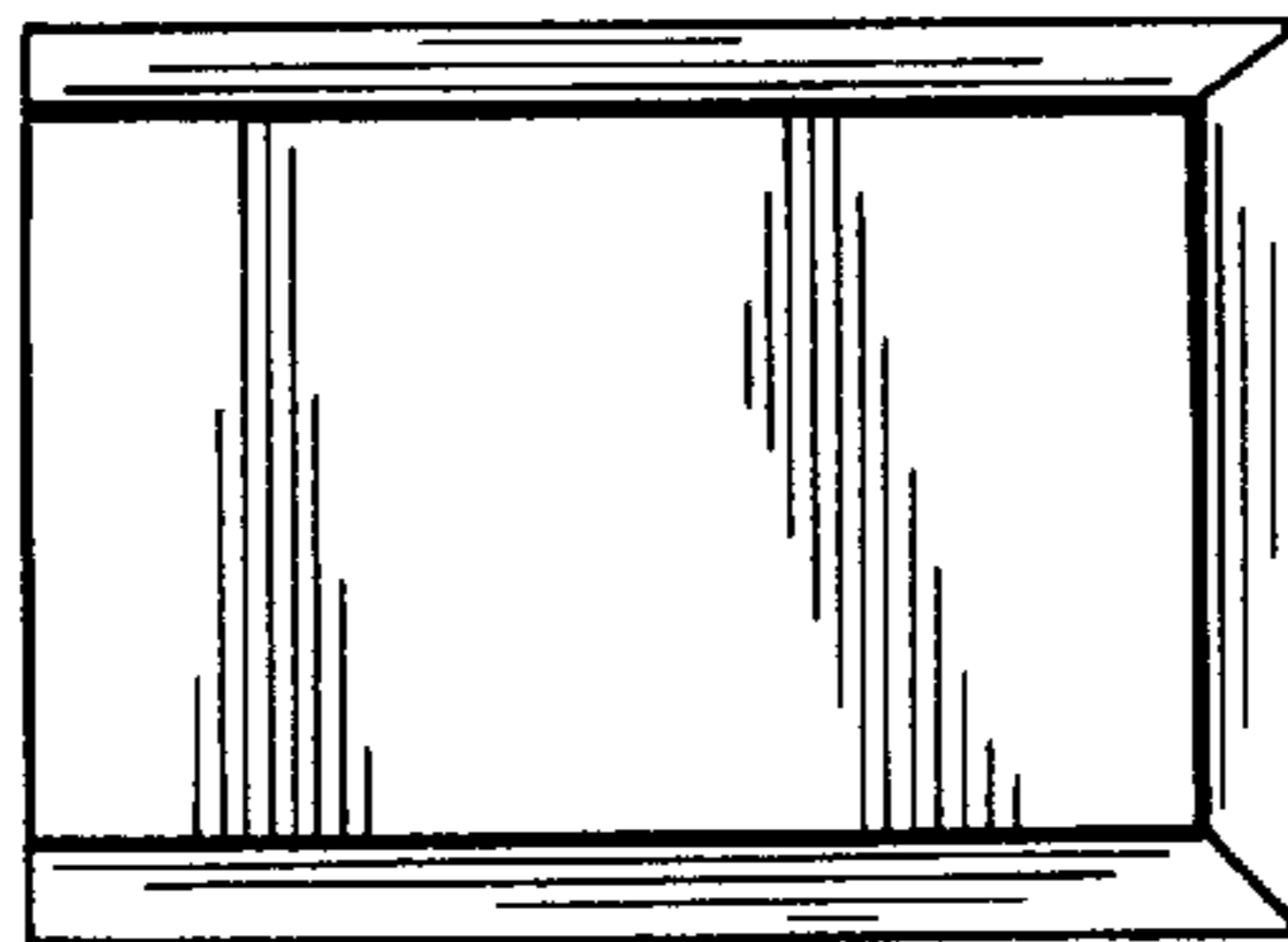

FIG. 7

