



US00D413124S

United States Patent [19]
McSpadden et al.

[11] **Patent Number: Des. 413,124**
[45] **Date of Patent: ** Aug. 24, 1999**

[54] **FUEL DISPENSING UNIT**

[75] Inventors: **John S. McSpadden**, Greensboro, N.C.; **Cheryl Felix**, Bedford; **Charles C. Keane**, Hingham, both of Mass.

[73] Assignee: **Gilbarco Inc.**, Greensboro, N.C.

[*] Notice: This patent is subject to a terminal disclaimer.

[**] Term: **14 Years**

[21] Appl. No.: **29/092,978**

[22] Filed: **Aug. 31, 1998**

[51] **LOC (6) Cl.** **15-02**

[52] **U.S. Cl.** **D15/9.1**

[58] **Field of Search** D15/9.1, 9.2; 137/234.6; 222/23, 26, 28, 71, 74, 372; 141/198; 251/129.64; D10/96; D99/28; D14/105

“V390U” (1994).
“Customer Interface Terminal”. No Date.
“Horizon 2000 Series Dispenser”. No Date.
“The Premier Series H422B: with Insight” (Aug. 1997).
“Dispensers”. No Date.
“The Advantage Series Model Guide” by Gilbarco Inc. (1996).
“Multidispenser Advantage”. No Date.
“Universal Univision” by Universal Epsco, Inc. (1995).
“Centurion—A Sophisticated and Reliable Dispenser” by Schlumberger Electronics Transaction (1997).

Primary Examiner—Ralf Seifert
Attorney, Agent, or Firm—Jenkins & Wilson, P.A.

[57] **CLAIM**

The ornamental design for a fuel dispensing unit, as shown and described.

DESCRIPTION

FIG. 1 is a right front perspective view of a fuel dispenser showing our new design;
FIG. 2 is a front elevational view thereof;
FIG. 3 is a right side elevational view wherein the left side is similar in appearance to the right side;
FIG. 4 is a left rear perspective view thereof;
FIG. 5 is a top plan view thereof; and,
FIG. 6 is a bottom view thereof.
The broken line showing of a fuel dispenser and hoses, in FIGS. 1–4 and 6 and partial hoses in FIG. 5 are for illustrative purposes only and forms no part of the claimed design.

[56] **References Cited**

U.S. PATENT DOCUMENTS

D. 235,917	7/1975	Hickey	D15/9.1
D. 244,563	5/1977	Taylor et al.	D52/2
D. 257,719	12/1980	Irion	D10/96
D. 262,971	2/1982	Robinson, Jr. et al.	D15/9.2
D. 265,092	6/1982	Robinson, Jr. et al.	D15/9.2
D. 306,719	3/1990	Austin et al.	D14/105
D. 309,144	7/1990	Austin et al.	D15/9.2
D. 315,740	3/1991	Mack	D15/9.1
D. 316,471	4/1991	Austin et al.	D99/43

OTHER PUBLICATIONS

“BP Apollo—NZ Trial Site Review” (Aug. 14, 1998).
“Loyalty Builders”. No Date.
“V390” (1994).

1 Claim, 3 Drawing Sheets

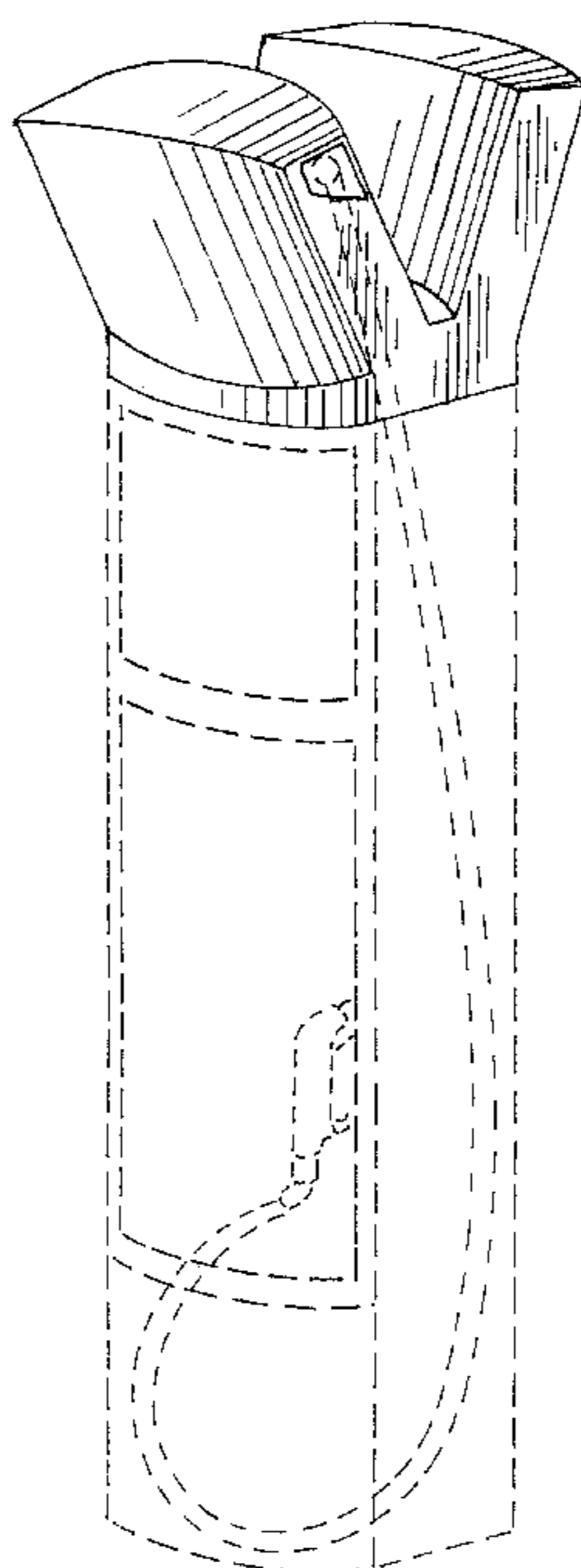

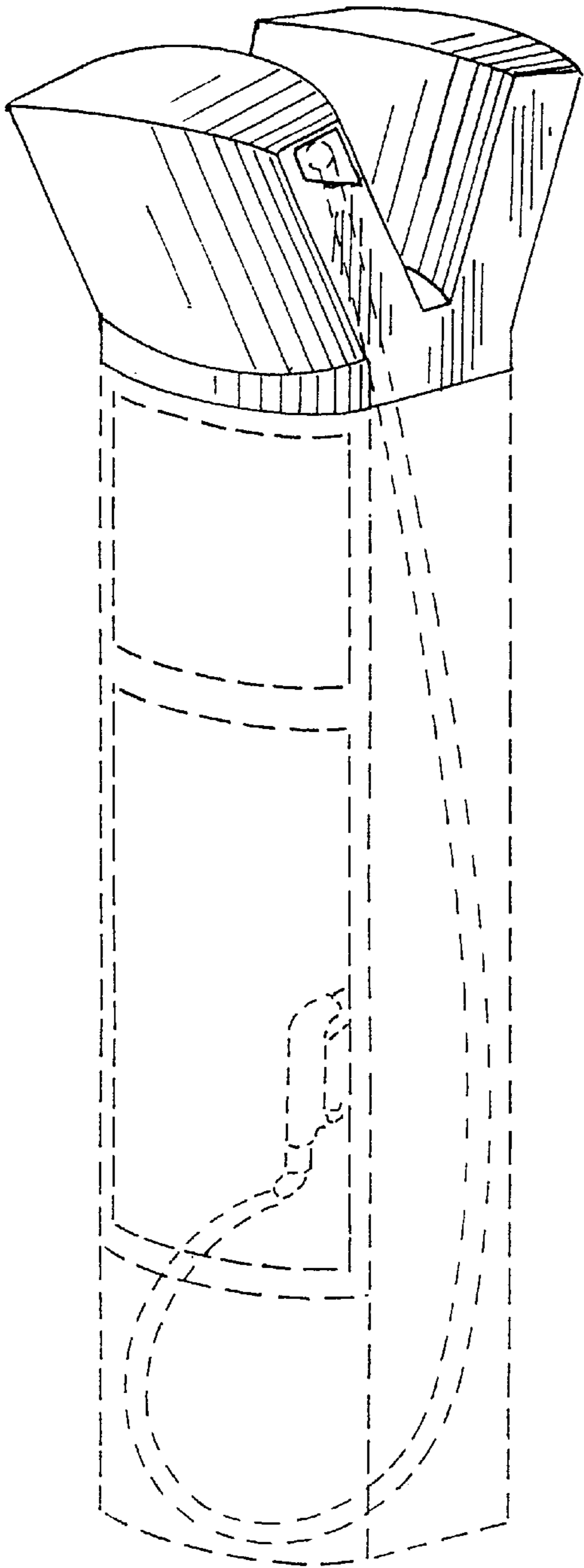

FIG.1

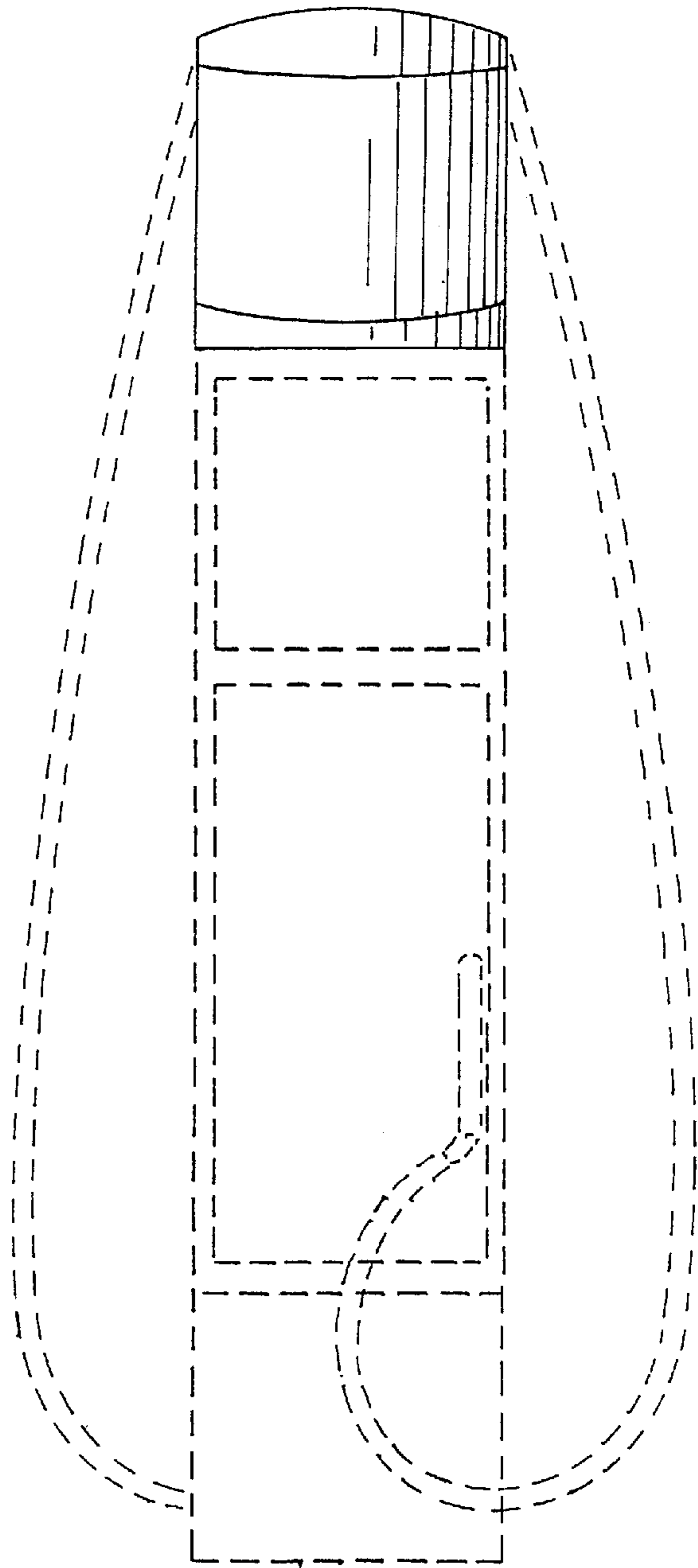

FIG.2

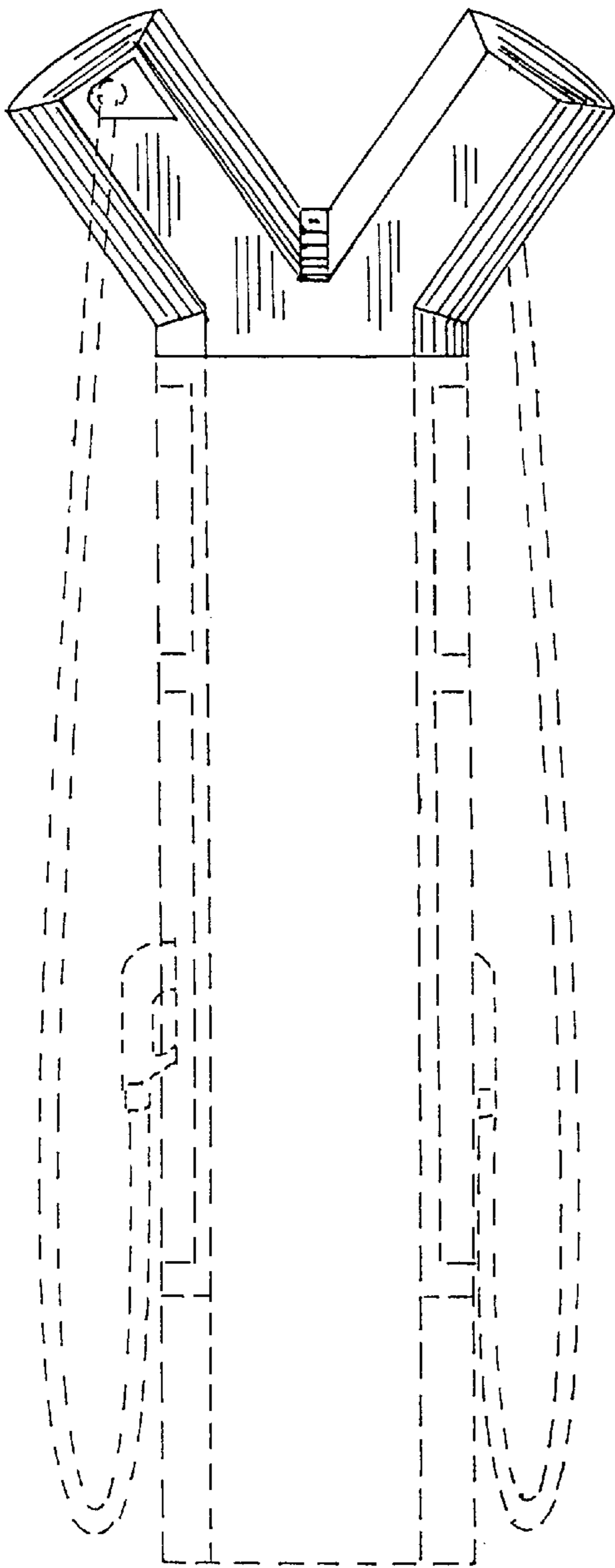

FIG 3

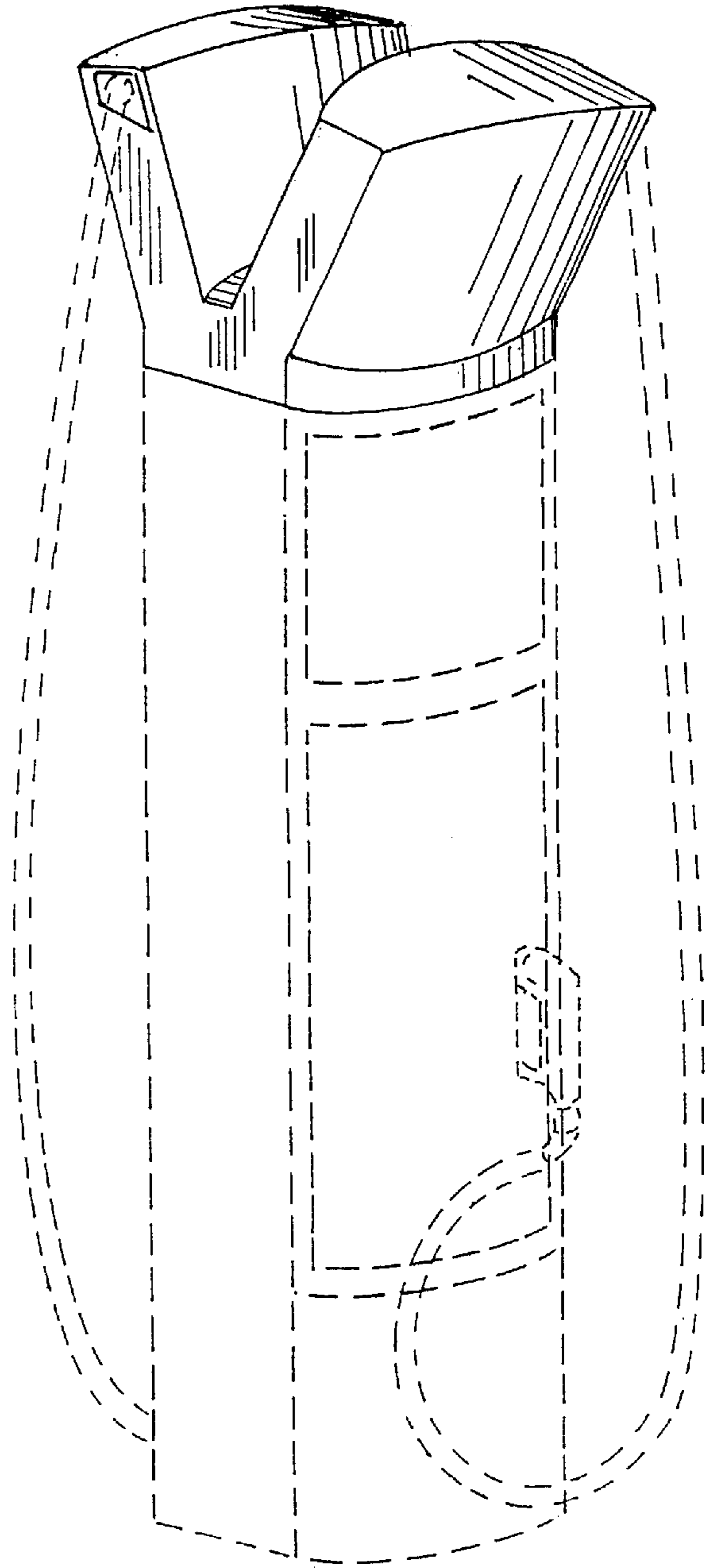

FIG.4

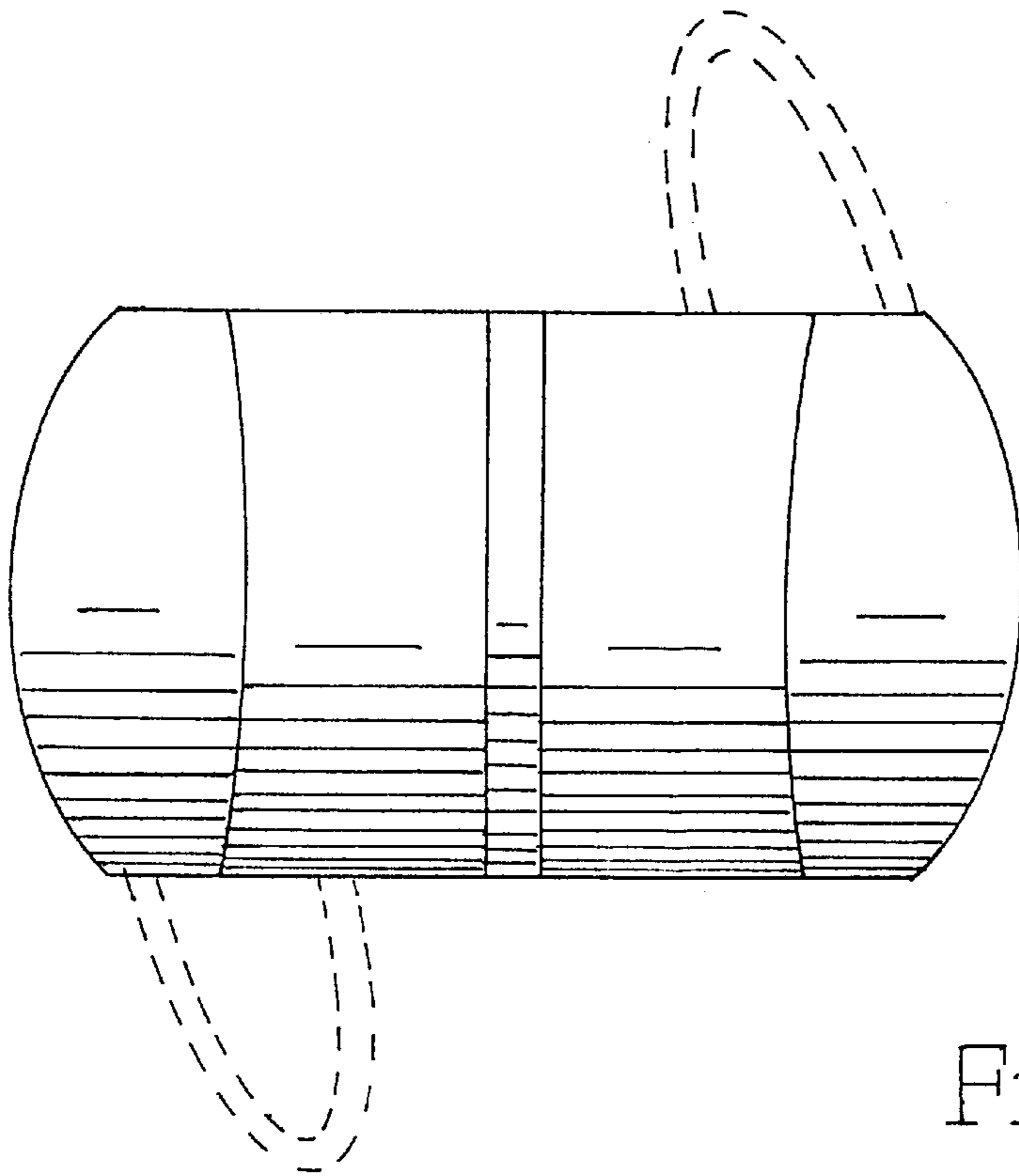

FIG. 5

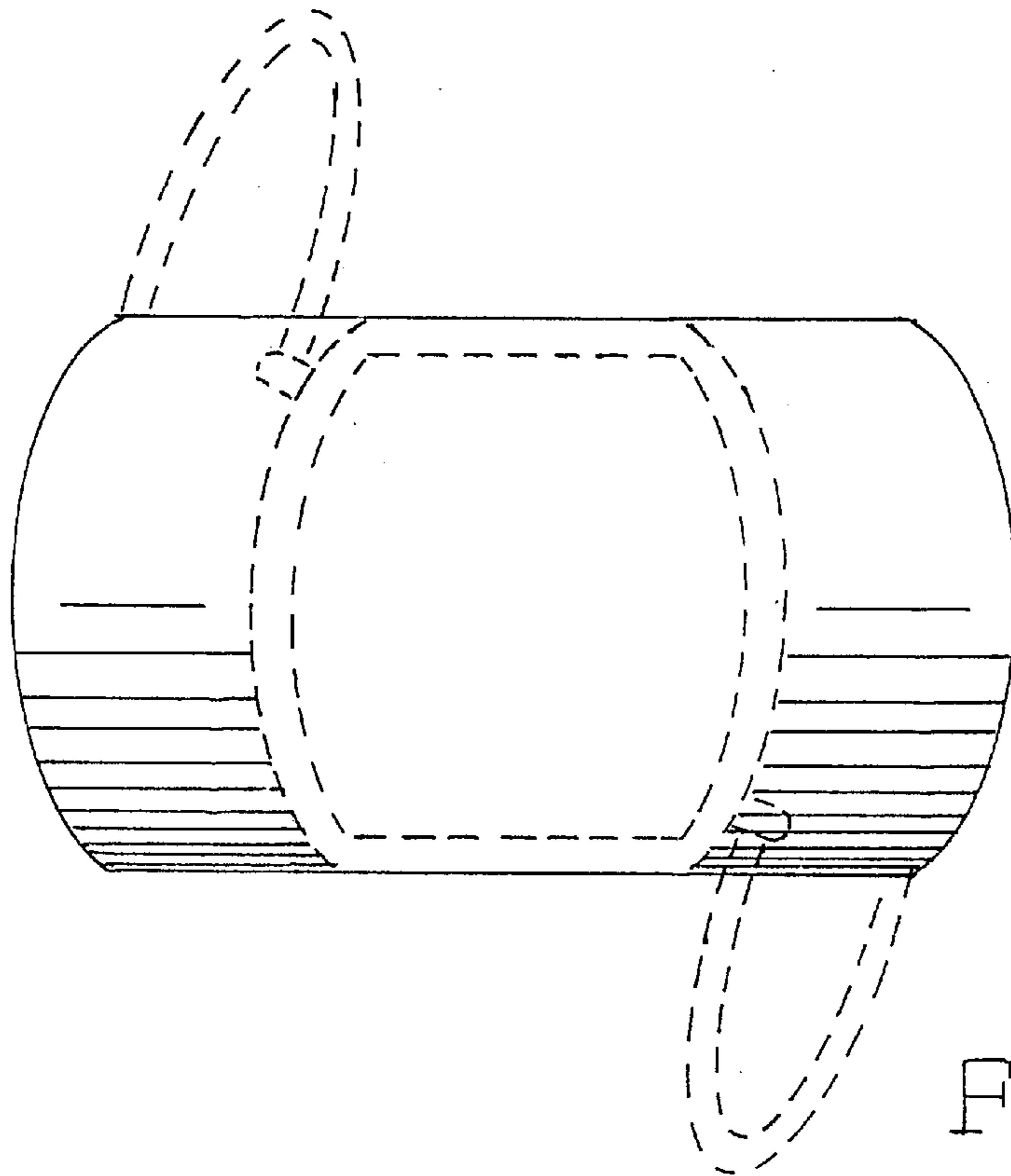

FIG. 6