



US00D412990S

United States Patent [19]

Woolston et al.

[11] Patent Number: **Des. 412,990**

[45] Date of Patent: **** Aug. 17, 1999**

[54] **MEDICAL TEST DEVICE**

[75] Inventors: **Robert Woolston**, Knebworth; **Bernard Sams**, London, both of United Kingdom

[73] Assignee: **Cortecs (UK) Limited**, Middlesex, United Kingdom

[**] Term: **14 Years**

[21] Appl. No.: **29/068,360**

[22] Filed: **Apr. 7, 1997**

[30] Foreign Application Priority Data

Oct. 7, 1996	[GB]	United Kingdom	2059870
Oct. 7, 1996	[GB]	United Kingdom	2059871
Oct. 7, 1996	[GB]	United Kingdom	2059872

[51] **LOC (6) Cl.** **28-03**

[52] **U.S. Cl.** **D24/223**

[58] **Field of Search** D24/223, 216, D24/224; 435/7.9, 7.1, 7.92, 287.1, 287.2, 975; 436/536; 422/57, 58, 56

[56] References Cited

U.S. PATENT DOCUMENTS

D. 342,575	12/1993	Ashihara et al.	D24/224
D. 379,662	6/1997	Pearson et al.	D24/223
D. 379,663	6/1997	Pearson et al.	D24/223
D. 394,317	5/1998	Carp	D24/223
3,252,331	5/1966	Lancaster	.	
4,116,637	9/1978	Kithara	.	
4,522,923	6/1985	Deutsch et al.	436/536
4,857,453	8/1989	Ullman et al.	435/7.92 X
5,204,063	4/1993	Allen	.	
5,339,829	8/1994	Thieme et al.	.	

FOREIGN PATENT DOCUMENTS

0 366 241	5/1990	European Pat. Off.	.
0 635 710	1/1995	European Pat. Off.	.
94 22011	9/1994	WIPO	.
97 18036	5/1997	WIPO	.

Primary Examiner—Stella Reid
Attorney, Agent, or Firm—Pennie & Edmonds LLP

[57] CLAIM

The ornamental design for a medical testing device, as shown and described.

DESCRIPTION

FIG. 1 is a top perspective view of a medical test device in accordance with the invention;
 FIG. 2 is a bottom perspective view of the device of FIG. 1;
 FIG. 3 is a top plan view of the device of FIG. 1;
 FIG. 4 is a bottom plan view of the device of FIG. 1;
 FIG. 5 is a right side view of the device of FIG. 1;
 FIG. 6 is a left side view of the device of FIG. 1;
 FIG. 7 is a front end view of the device of FIG. 1;
 FIG. 8 is a rear end view of the device of FIG. 1;
 FIG. 9 is a top perspective view of the housing portion of the device of FIG. 1;
 FIG. 10 is a bottom perspective view of the housing portion of FIG. 9;
 FIG. 11 is a top plan view of housing portion of FIG. 9;
 FIG. 12 is a bottom plan view of the housing portion of FIG. 9;
 FIG. 13 is a right side view of the housing portion of FIG. 9;
 FIG. 14 is a left side view of the housing portion of FIG. 9;
 FIG. 15 is a front end view of the housing portion of FIG. 9;
 FIG. 16 is a rear end view of the housing portion of FIG. 9;
 FIG. 17 is a top perspective of one collector portion that forms part of the device of FIG. 1;
 FIG. 18 is a top plan view of the collector portion of FIG. 17 with the bottom view being the same as the top view;
 FIG. 19 is a side view of the collector portion of FIG. 17;
 FIG. 20 is a front end view of the collector portion of FIG. 17; and,
 FIG. 21 is a rear end view of the collector portion of FIG. 17.

1 Claim, 5 Drawing Sheets

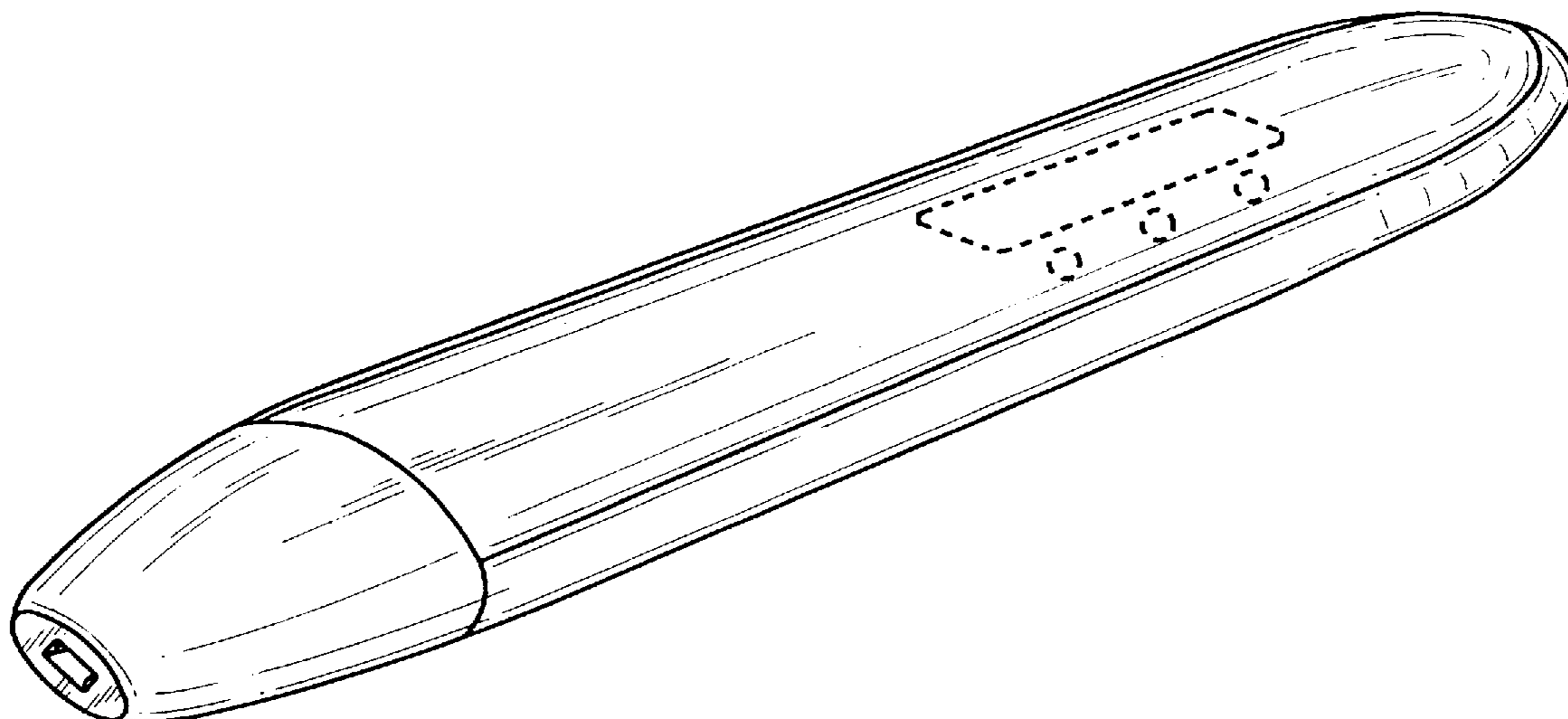

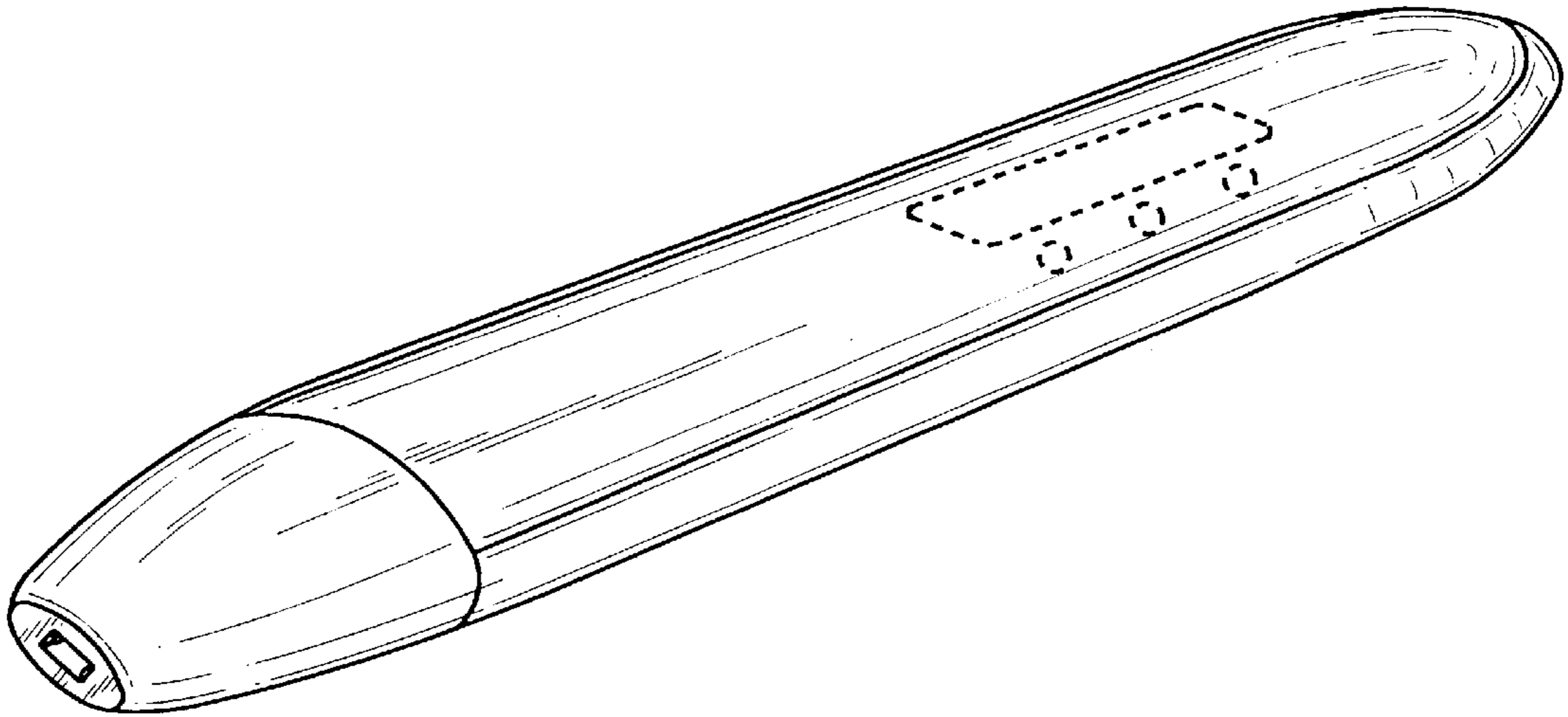

FIG. 1

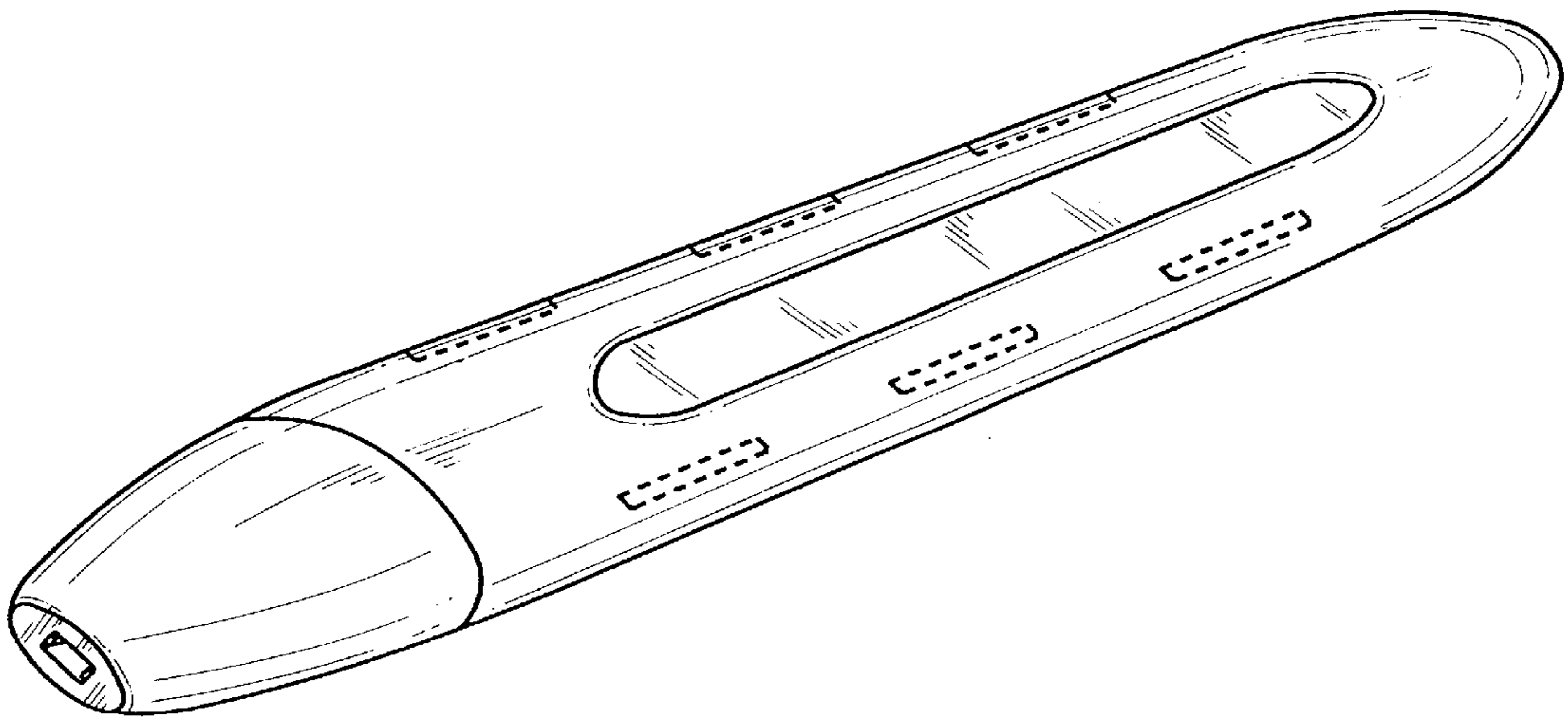

FIG. 2

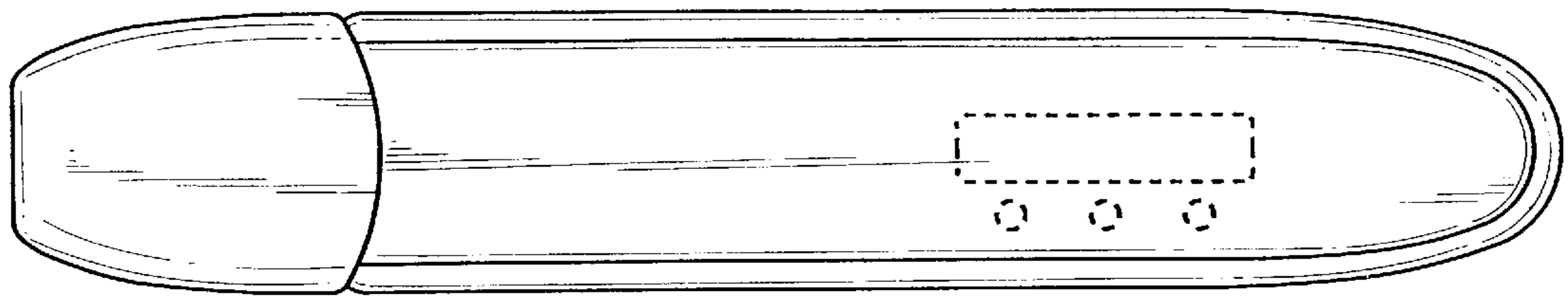

FIG. 3

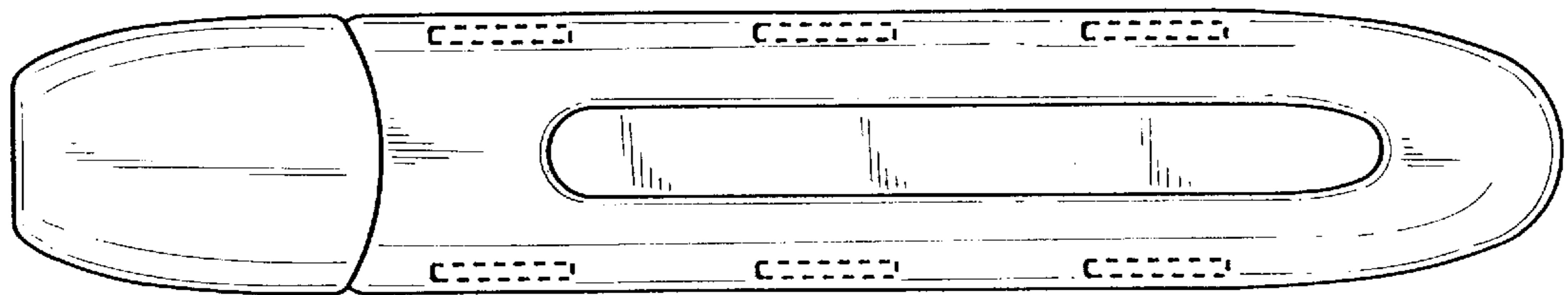

FIG. 4

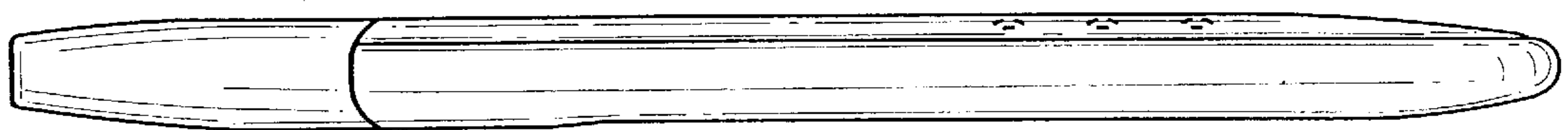

FIG. 5

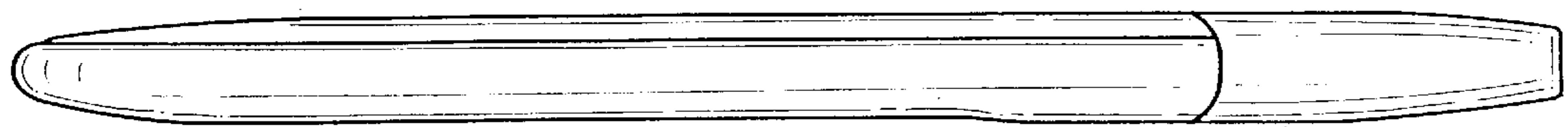

FIG. 6

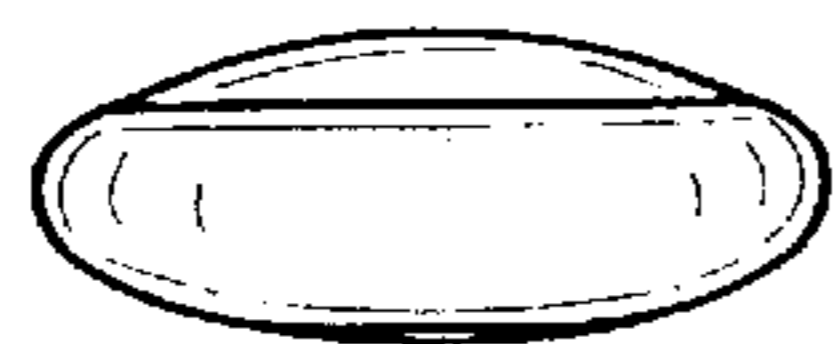

FIG. 7

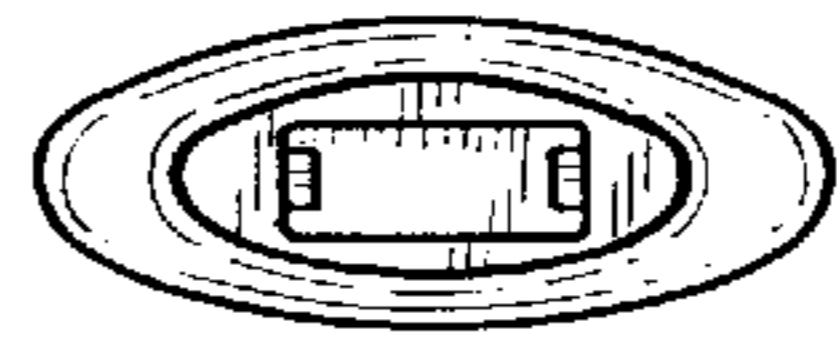

FIG. 8

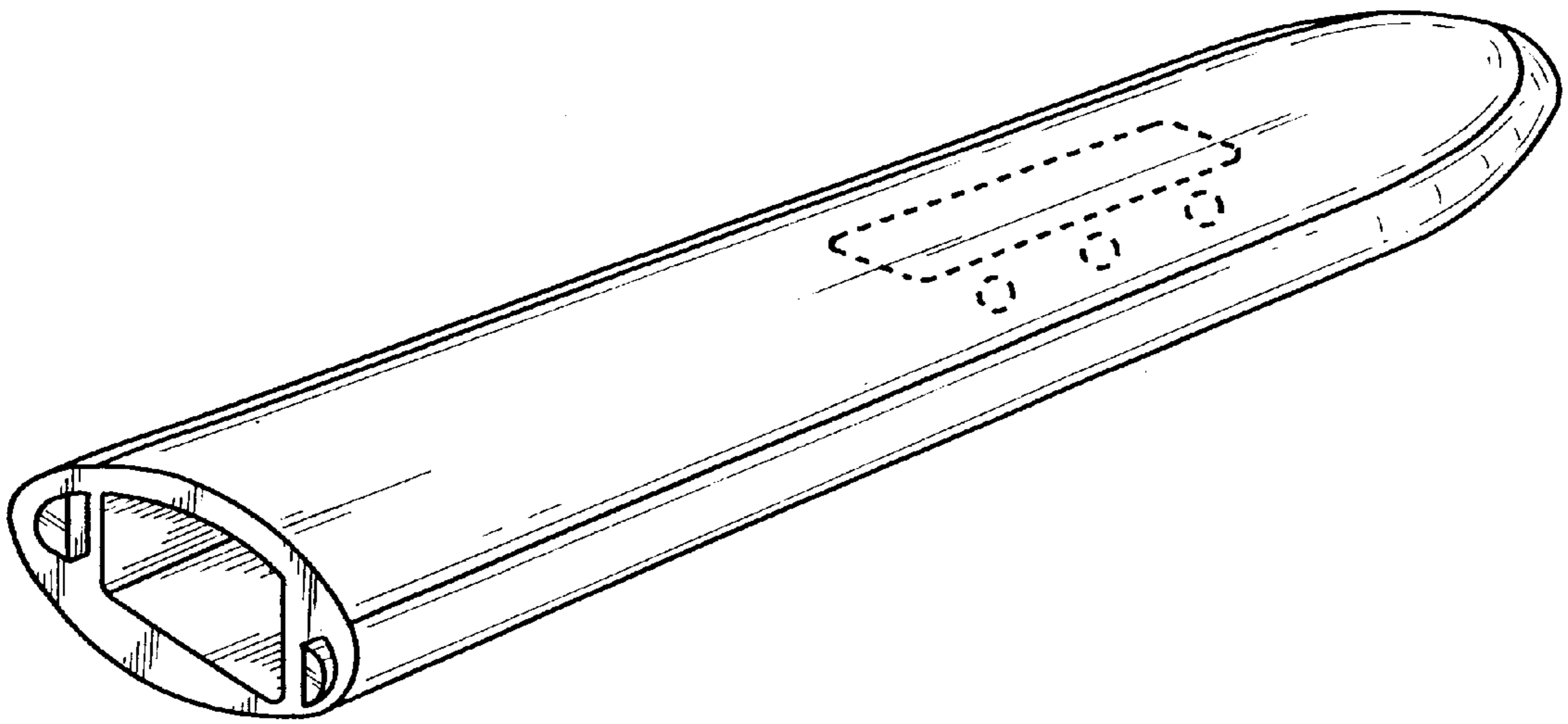

FIG. 9

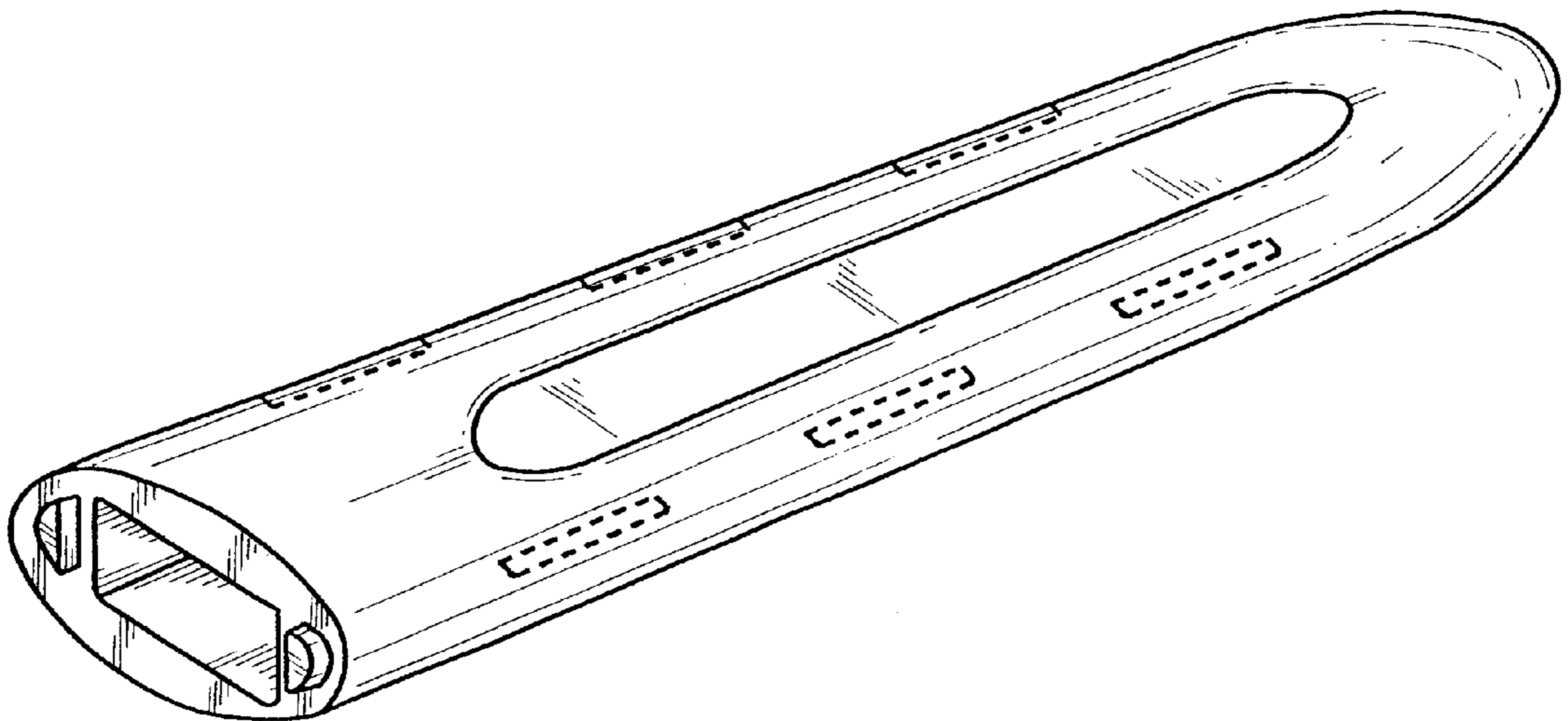

FIG. 10

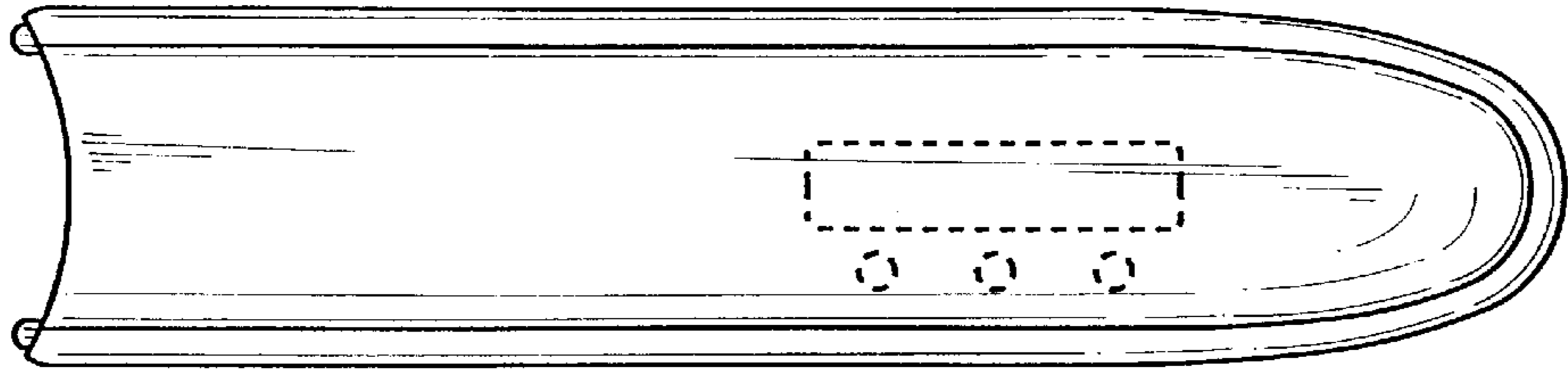

FIG. 11

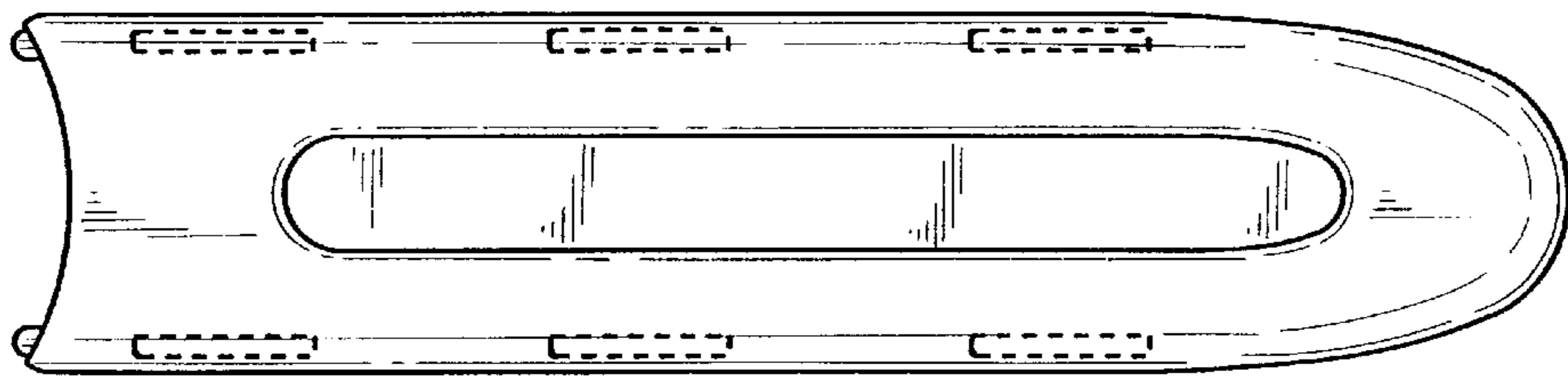

FIG. 12

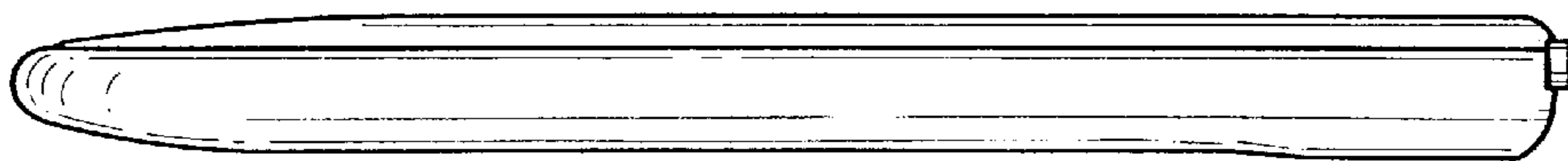

FIG. 14

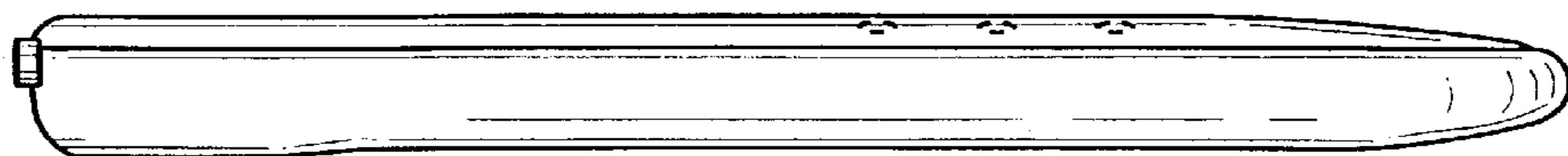

FIG. 13



FIG. 15

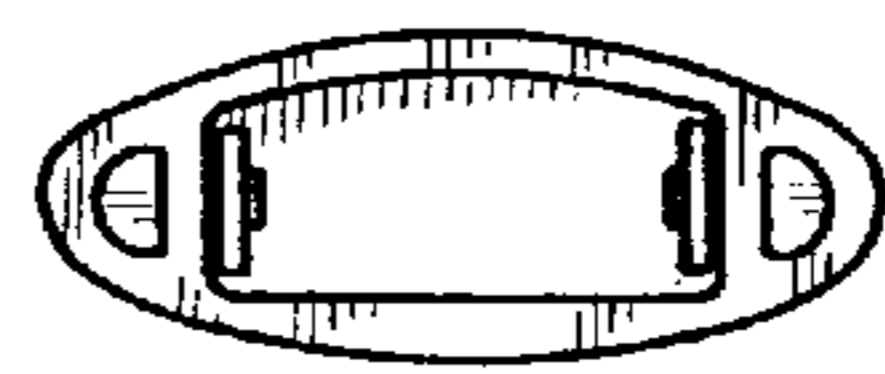

FIG. 16

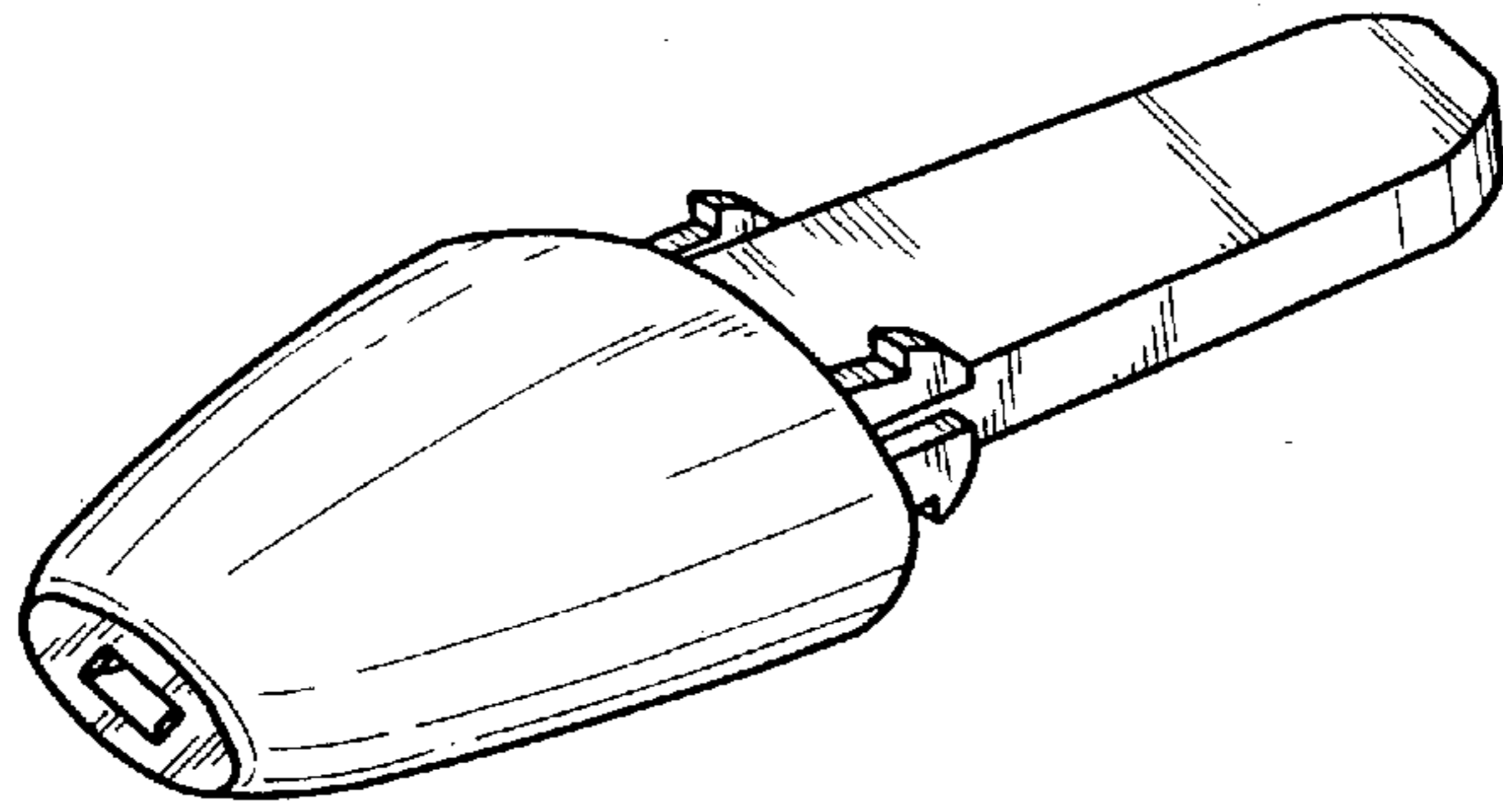

FIG. 17

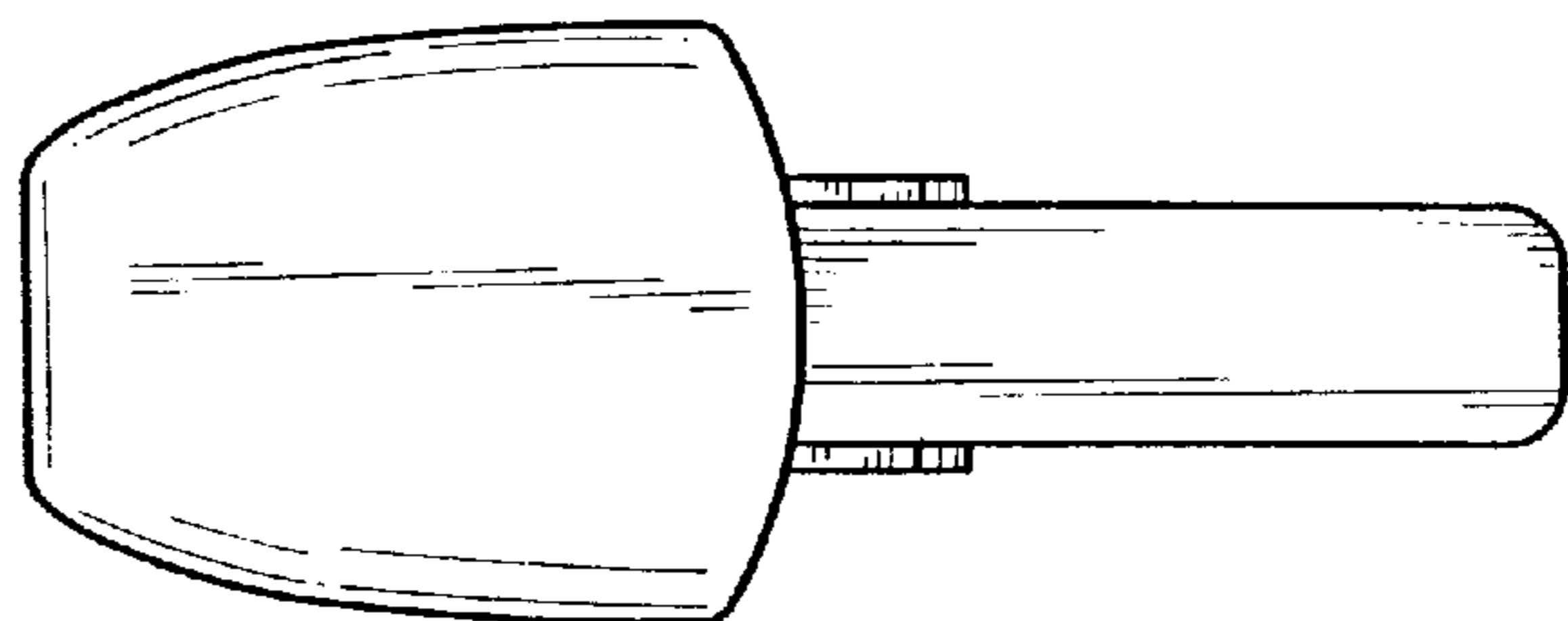

FIG. 18

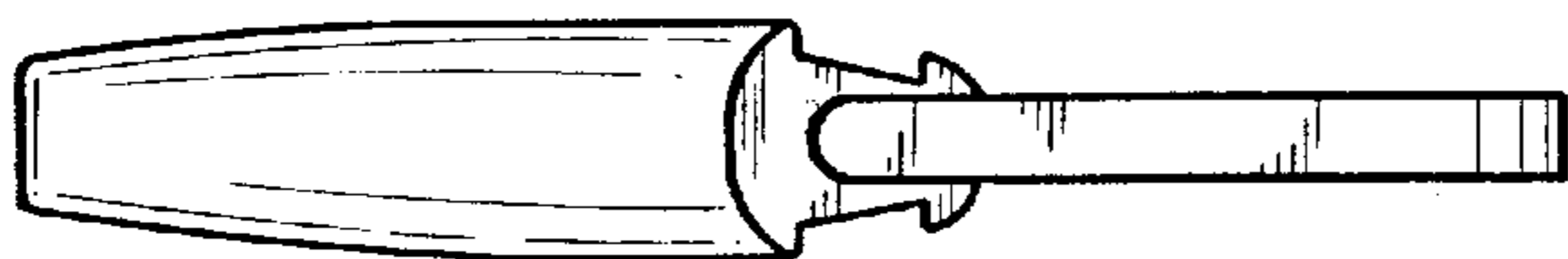

FIG. 19

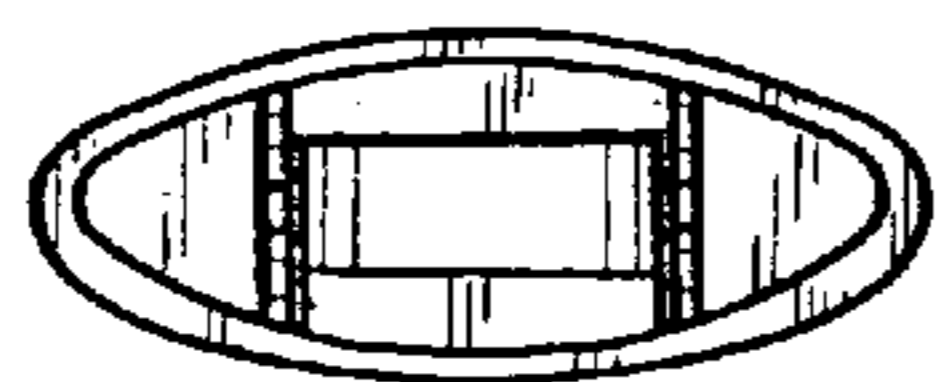

FIG. 20

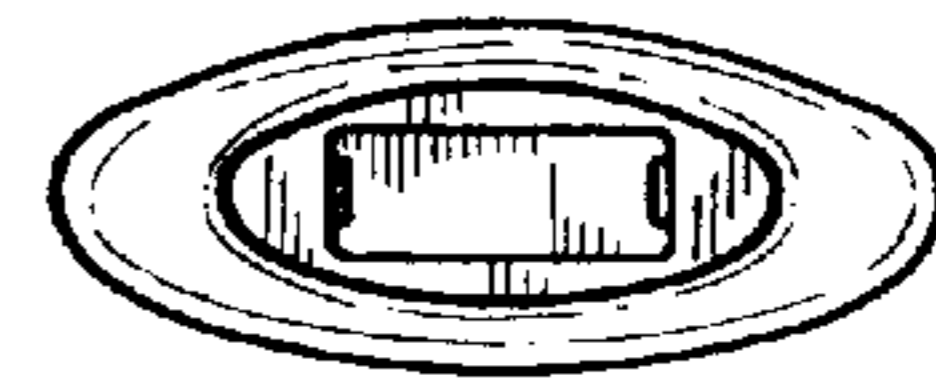

FIG. 21