



US00D412940S

# United States Patent [19]

Kato et al.

[11] Patent Number: Des. 412,940

[45] Date of Patent: \*\* Aug. 17, 1999

[54] VIDEO GAME MACHINE

[75] Inventors: **Katsumi Kato**, Yokohama; **Akitoshi Oikawa**, Tokyo, both of Japan

[73] Assignee: **Sega Enterprises, Ltd.**, Tokyo, Japan

[\*\*] Term: 14 Years

[21] Appl. No.: 29/095,947

[22] Filed: Nov. 2, 1998

### [30] Foreign Application Priority Data

May 14, 1998 [JP] Japan ..... 10-13795

[51] LOC (6) Cl. .... 21-01

[52] U.S. Cl. .... D21/324; D14/117.9

[58] Field of Search ..... D21/324, 328-333;  
D14/117.1, 117.9; 273/148 B; 463/1, 29-35,  
43-47

### [56] References Cited

#### U.S. PATENT DOCUMENTS

- D. 320,624 10/1991 Taylor ..... D21/331
- D. 375,126 10/1996 Ikenaga ..... D21/330

- D. 380,501 7/1997 Osterhout et al. .... D14/117.9 X
- D. 387,392 12/1997 Lien ..... D14/117.9
- 5,184,830 2/1993 Okada et al. .... 463/29
- 5,213,327 5/1993 Kitaue ..... 273/148 B

Primary Examiner—Prabhakar Deshmukh  
Attorney, Agent, or Firm—Dickstein Shapiro Morin & Oshinsky LLP

### [57] CLAIM

The ornamental design for the video game machine, as shown and described.

### DESCRIPTION

FIG. 1 is a front, top and right side perspective view of a video game machine showing our new design;  
 FIG. 2 is a bottom, rear and left side perspective view thereof;  
 FIG. 3 is a front elevational view thereof;  
 FIG. 4 is a rear elevational view thereof;  
 FIG. 5 is a top plan view thereof;  
 FIG. 6 is a bottom plan view thereof;  
 FIG. 7 is a right side elevational view thereof; and,  
 FIG. 8 is a left side elevational view thereof.

1 Claim, 6 Drawing Sheets

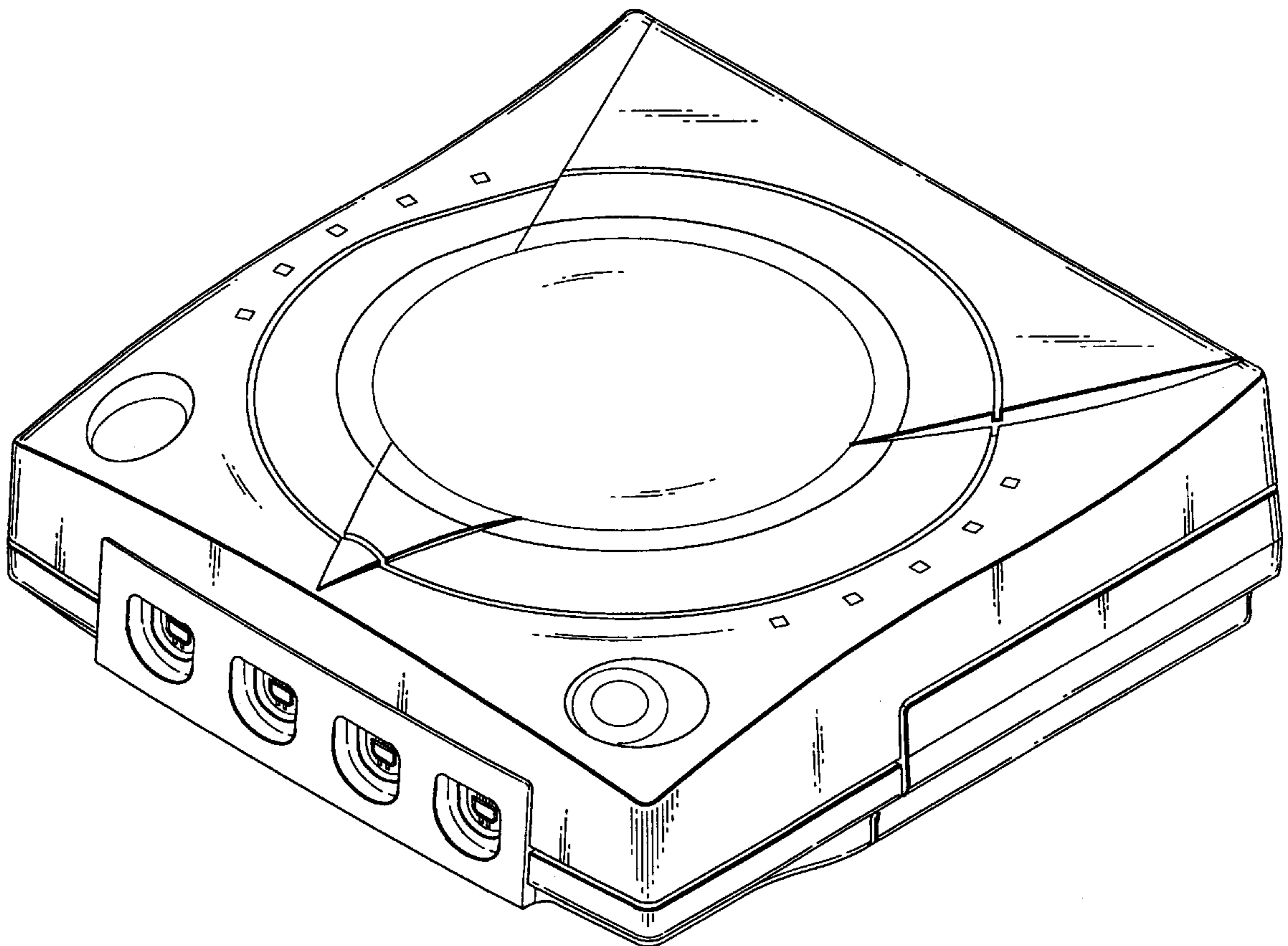

FIG. 1

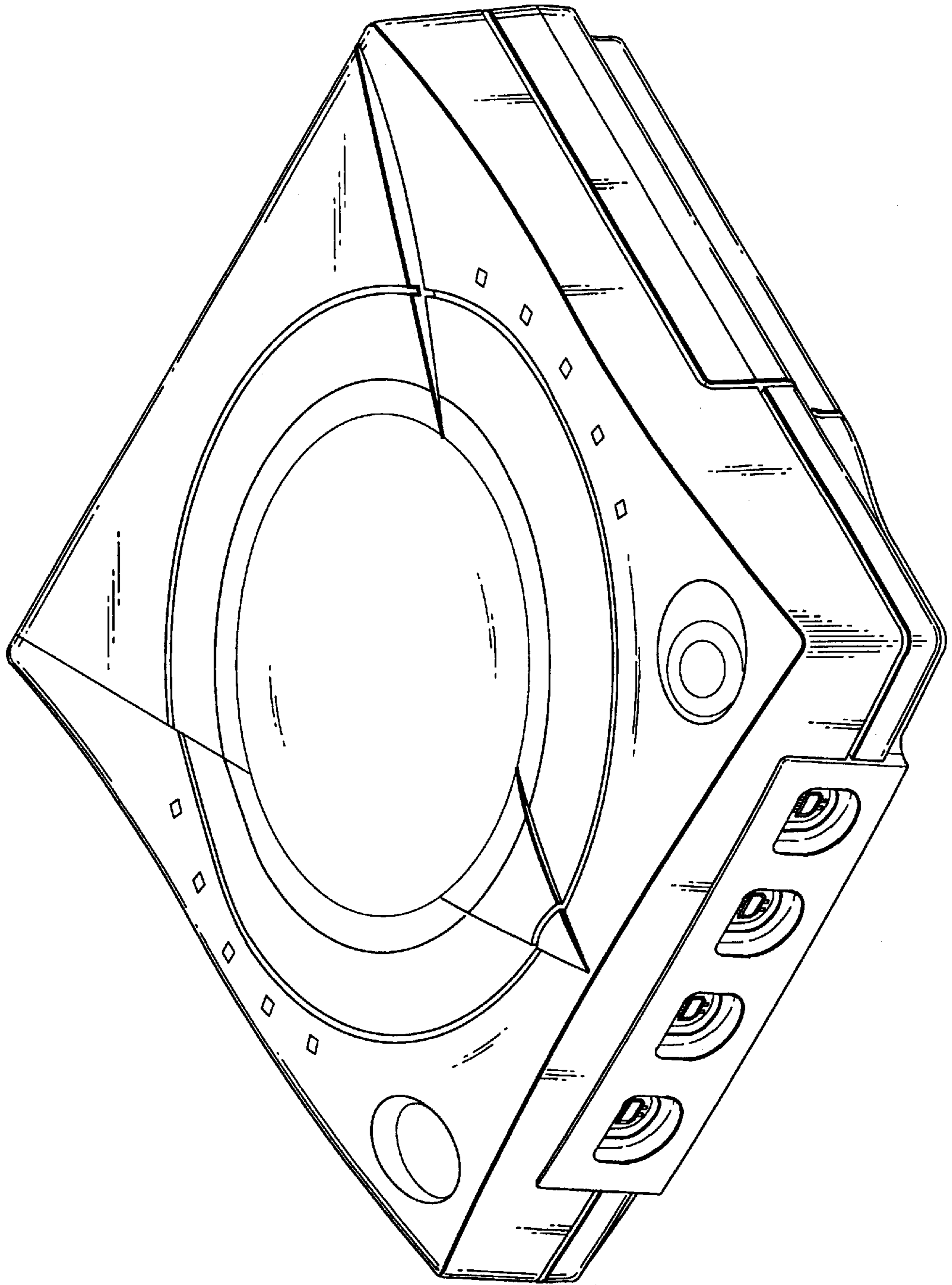

FIG. 2

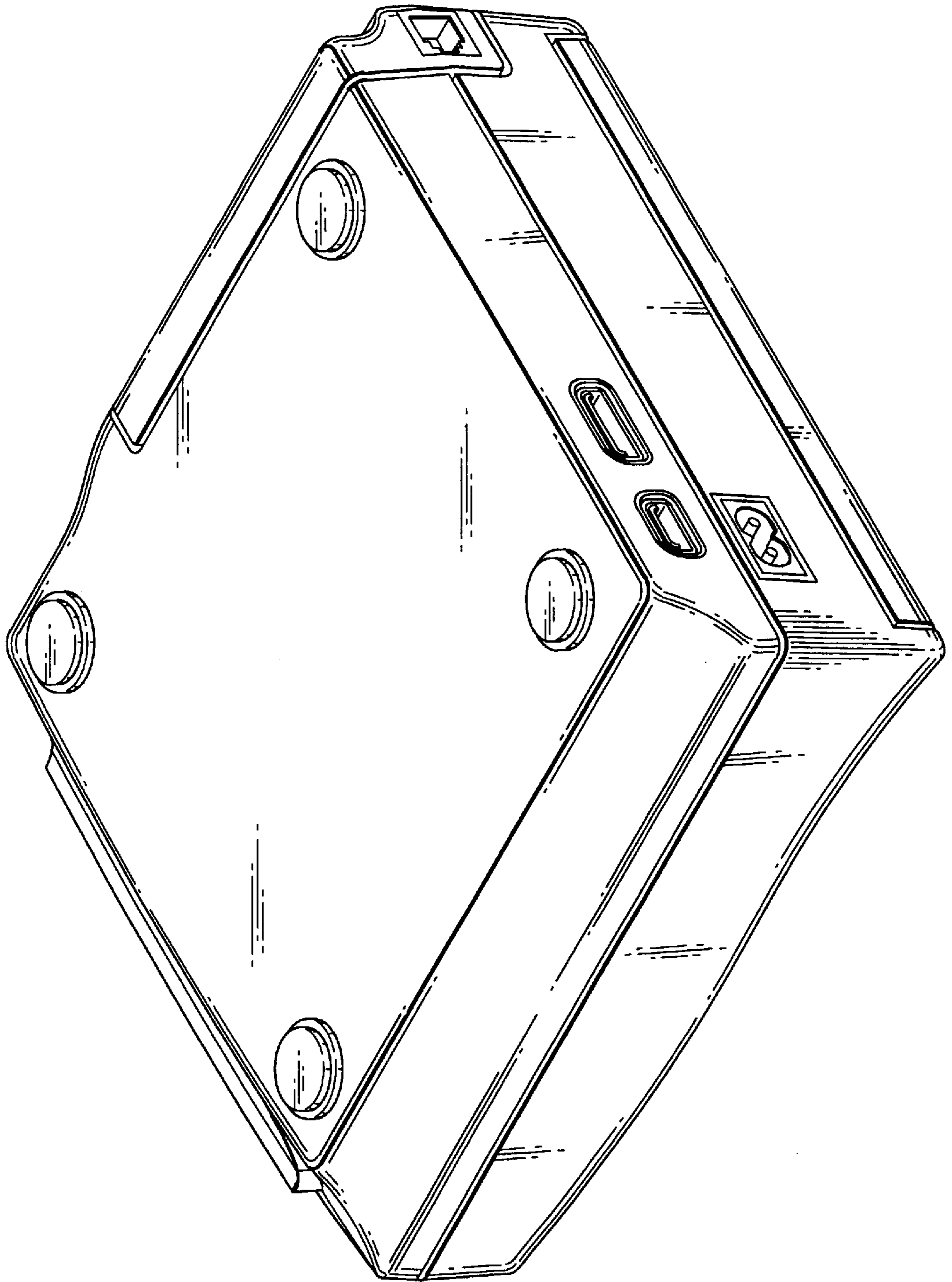

FIG. 3

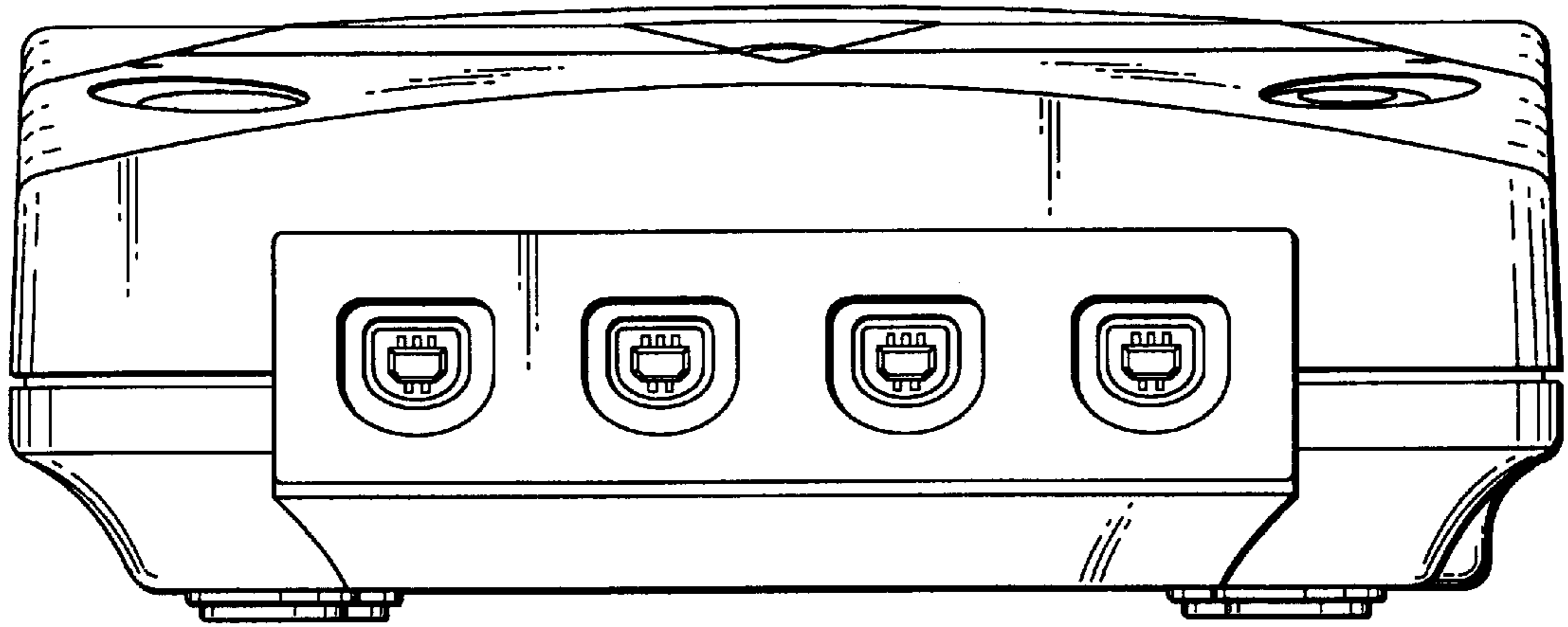

FIG. 4

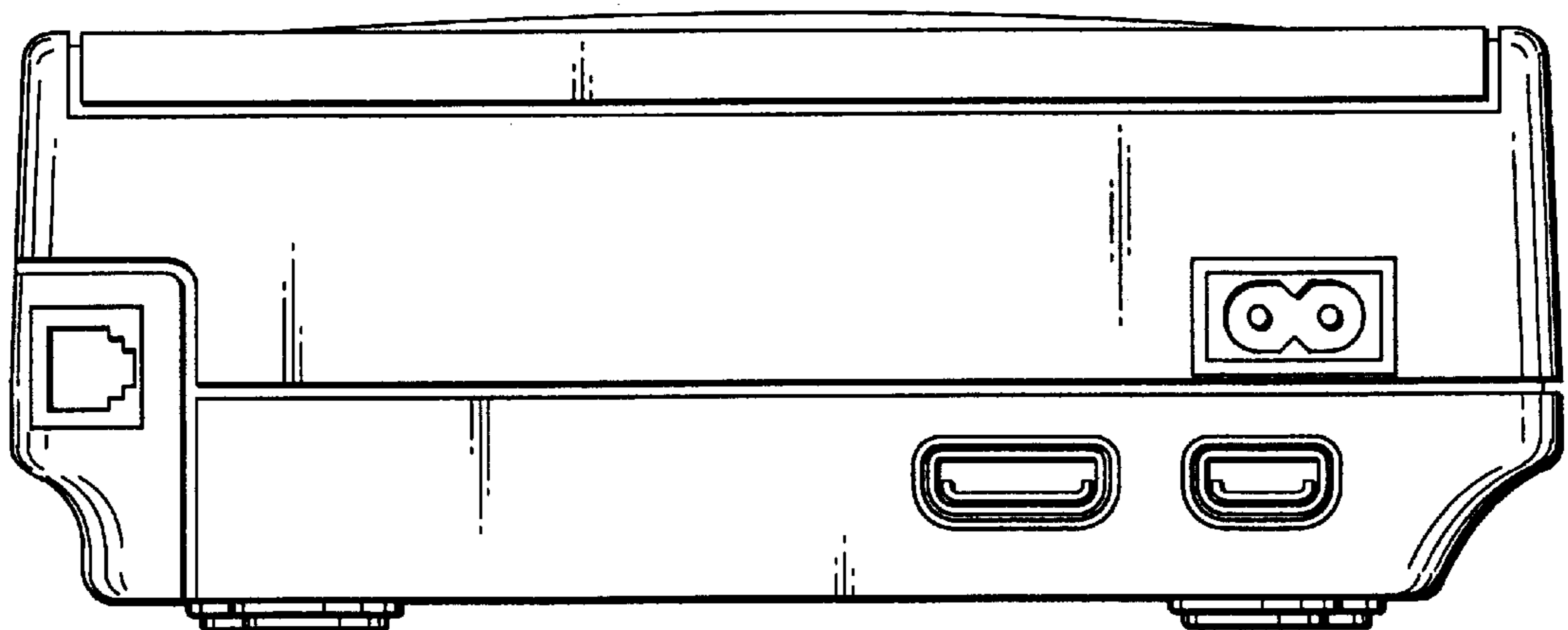

FIG. 5

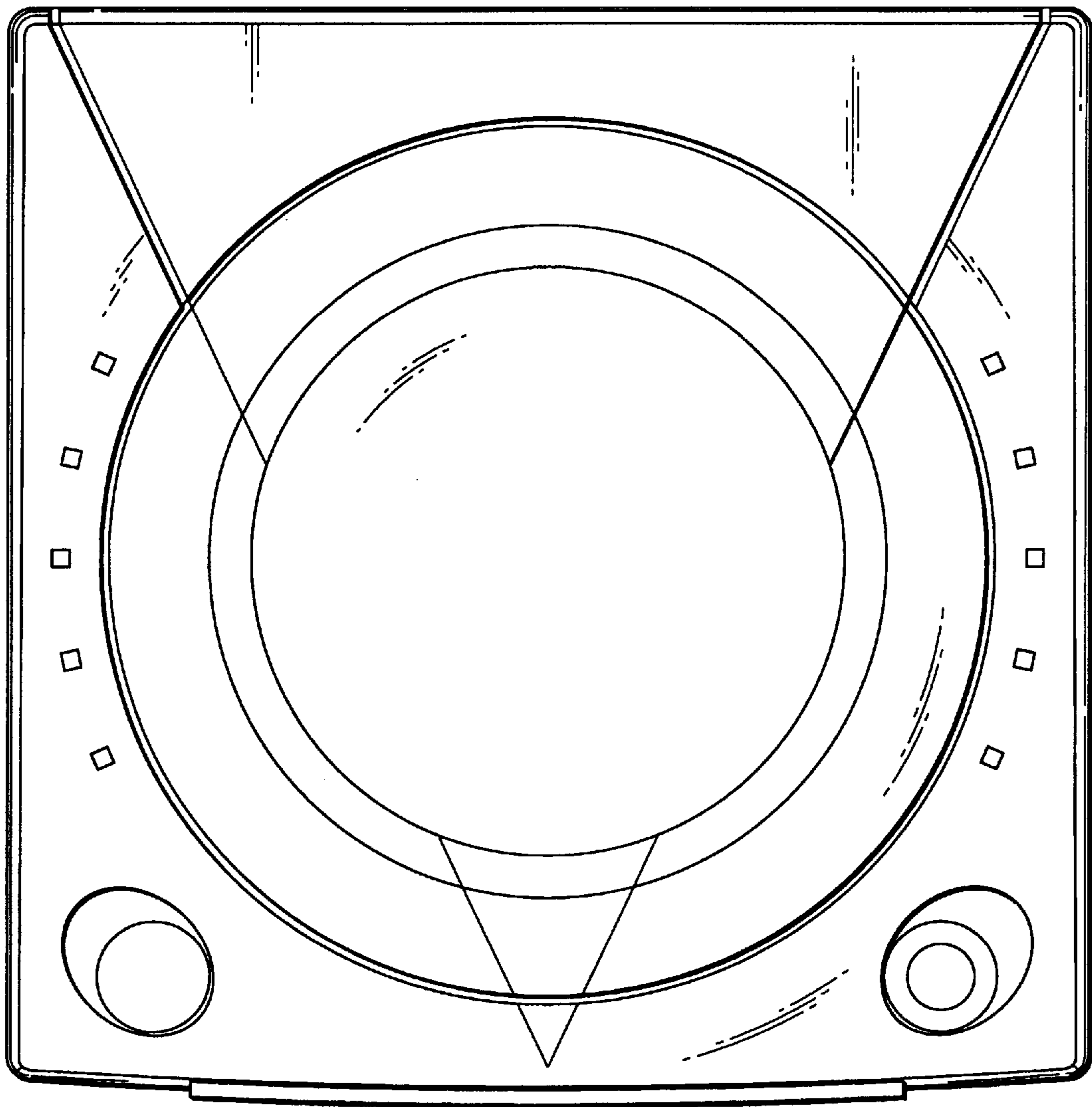

FIG. 6

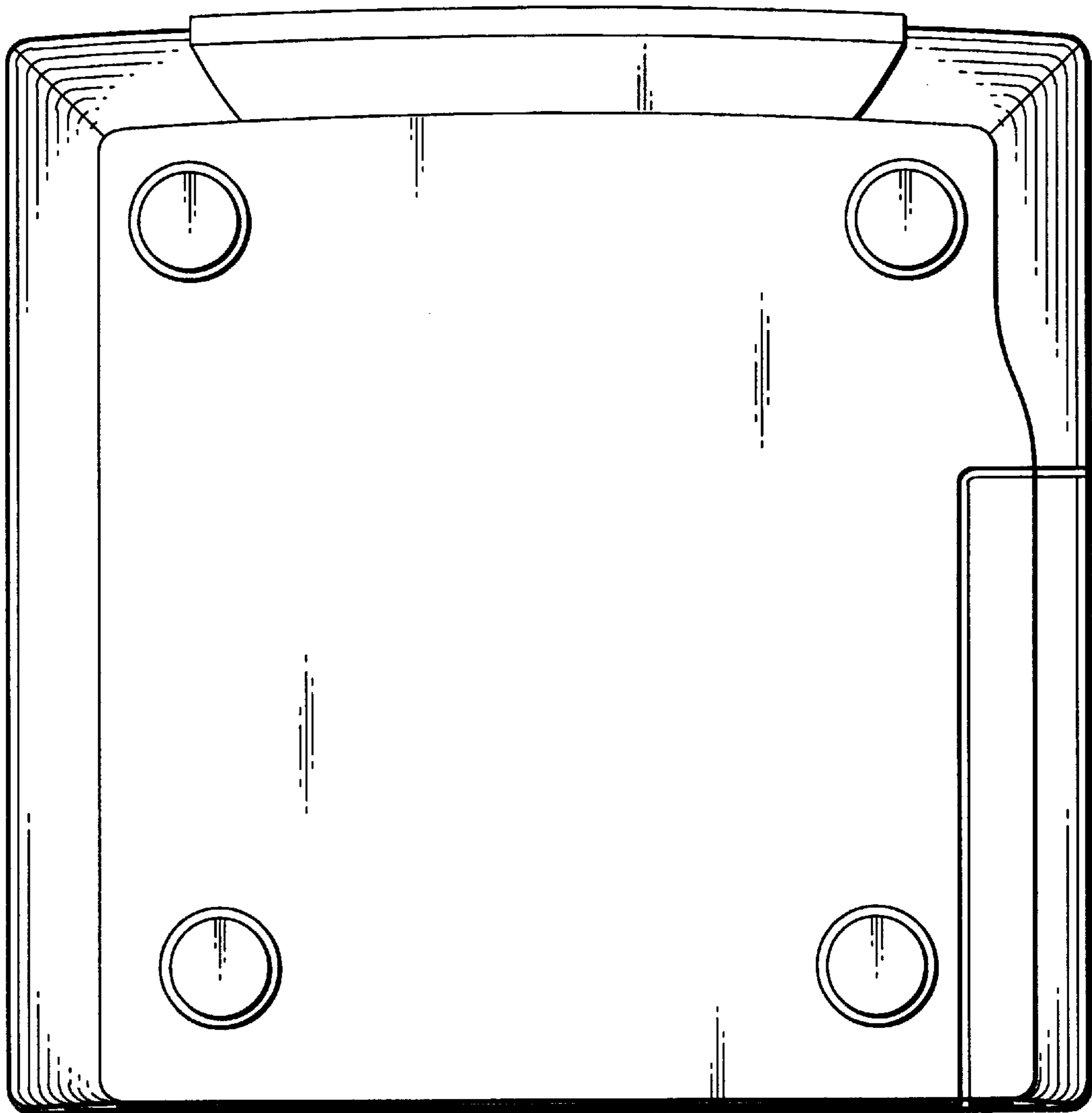

FIG. 7

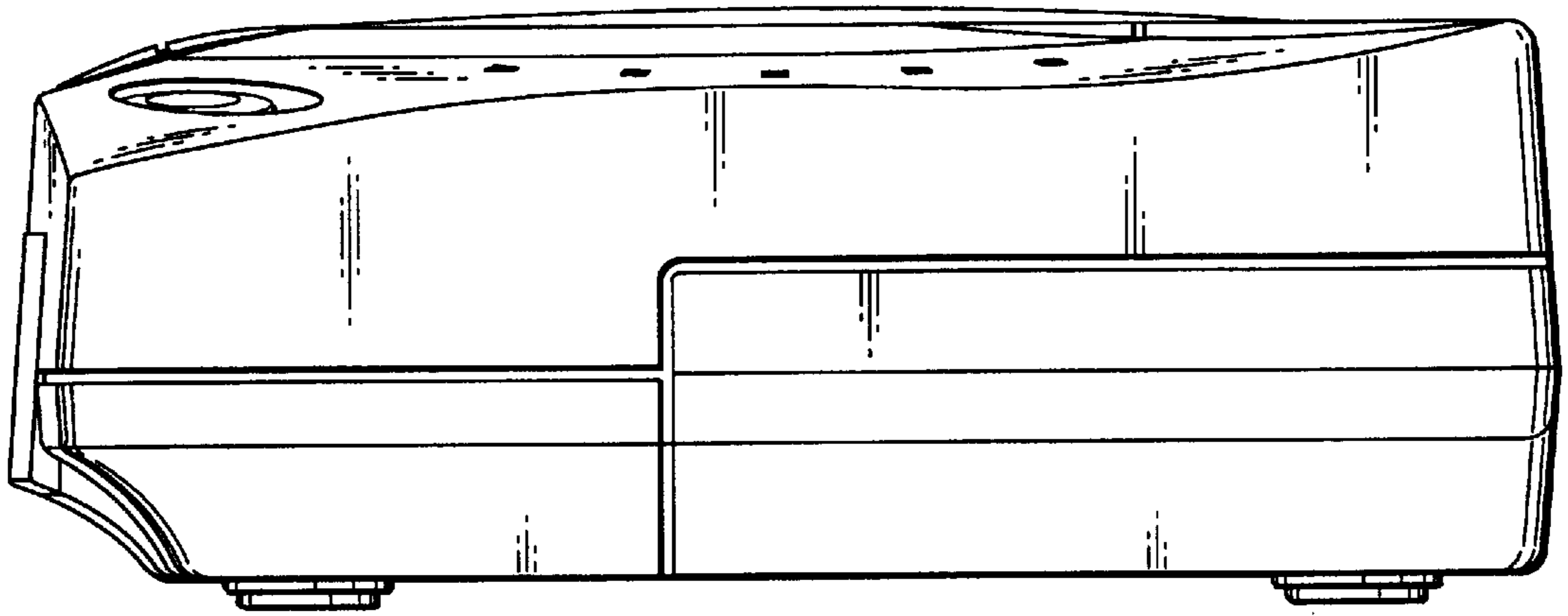

FIG. 8

