



US00D412866S

**United States Patent** [19]  
**Bidwell et al.**

[11] **Patent Number: Des. 412,866**  
[45] **Date of Patent: \*\* Aug. 17, 1999**

[54] **PERSONNEL CARRYING VEHICLE**

OTHER PUBLICATIONS

[75] Inventors: **Thomas Bidwell**, St. Marys; **Michael P. Gallagher**, Greenville; **Kevin A. Gilliland**; **Joseph H. Knapschaefer**, both of Coldwater; **Donald E. Luebrecht**, Ft. Jennings, all of Ohio; **John F. McClusky**, Pittsburgh, Pa.; **Leif A. Norland**, St. Marys, Ohio; **Steven R. Puskamp**, New Bremen, Ohio; **Harold A. Stammen**, New Bremen, Ohio; **Robert J. Stauffer**, New Bremen, Ohio

*New Equipment Digest*—Jul. 1982 —p. 23 Work Platform at middle, 1982.

*Primary Examiner*—Nelson C. Holtje  
*Attorney, Agent, or Firm*—Killworth, Gottman, Hagan & Schaeff, LLP

[73] Assignee: **Crown Equipment Corporation**, New Bremen, Ohio

[\*\*] Term: **14 Years**

[21] Appl. No.: **29/059,617**

[22] Filed: **Sep. 13, 1996**

[51] **LOC (6) Cl.** ..... **12-14**

[52] **U.S. Cl.** ..... **D12/1**

[58] **Field of Search** ..... D12/1, 14, 16;  
182/63, 148, 141, 144; 187/223, 243; 414/632

[56] **References Cited**

U.S. PATENT DOCUMENTS

4,258,825	3/1981	Collins	182/148	X
5,044,472	9/1991	Dammeyer	187/223	
5,203,425	4/1993	Wehmeyer	182/63	X
5,273,132	12/1993	Sasaki	182/148	
7,929,524	3/1960	Carlson	414/632	

[57] **CLAIM**

The ornamental design for a personnel carrying vehicle, as shown and described.

**DESCRIPTION**

FIG. 1 is a perspective view of a personnel carrying vehicle showing our new design, the view being taken from above the left front of the vehicle;

FIG. 2 is a perspective view of the design, as taken from above the left rear of the vehicle;

FIG. 3 is a perspective view of the design, taken from above the right rear of the vehicle;

FIG. 4 is a elevational view of the left side of the vehicle, the right side is symmetrical;

FIG. 5 is a front elevational view of the vehicle design;

FIG. 6 is a front perspective view of the design;

FIG. 7 is a rear elevational view of the design;

FIG. 8 is a rear perspective view of the design;

FIG. 9 is a rear perspective view of the design, showing the vehicle gates in the open position; and,

FIG. 10 is a perspective view of the design, taken from the above left of the vehicle, with the operator platform in the raised position.

The bottom of the vehicle is plain and unornamented.

**1 Claim, 10 Drawing Sheets**

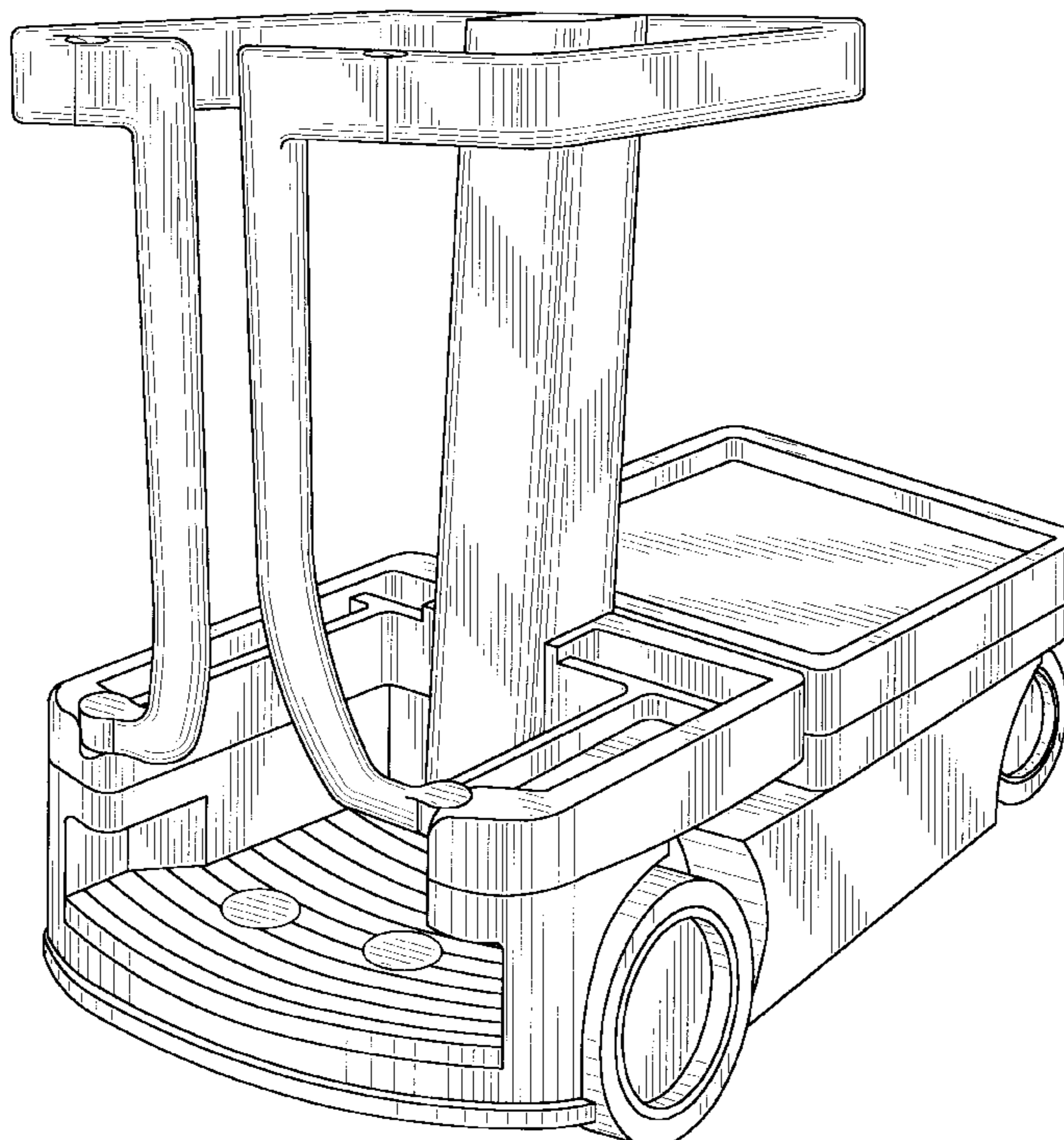

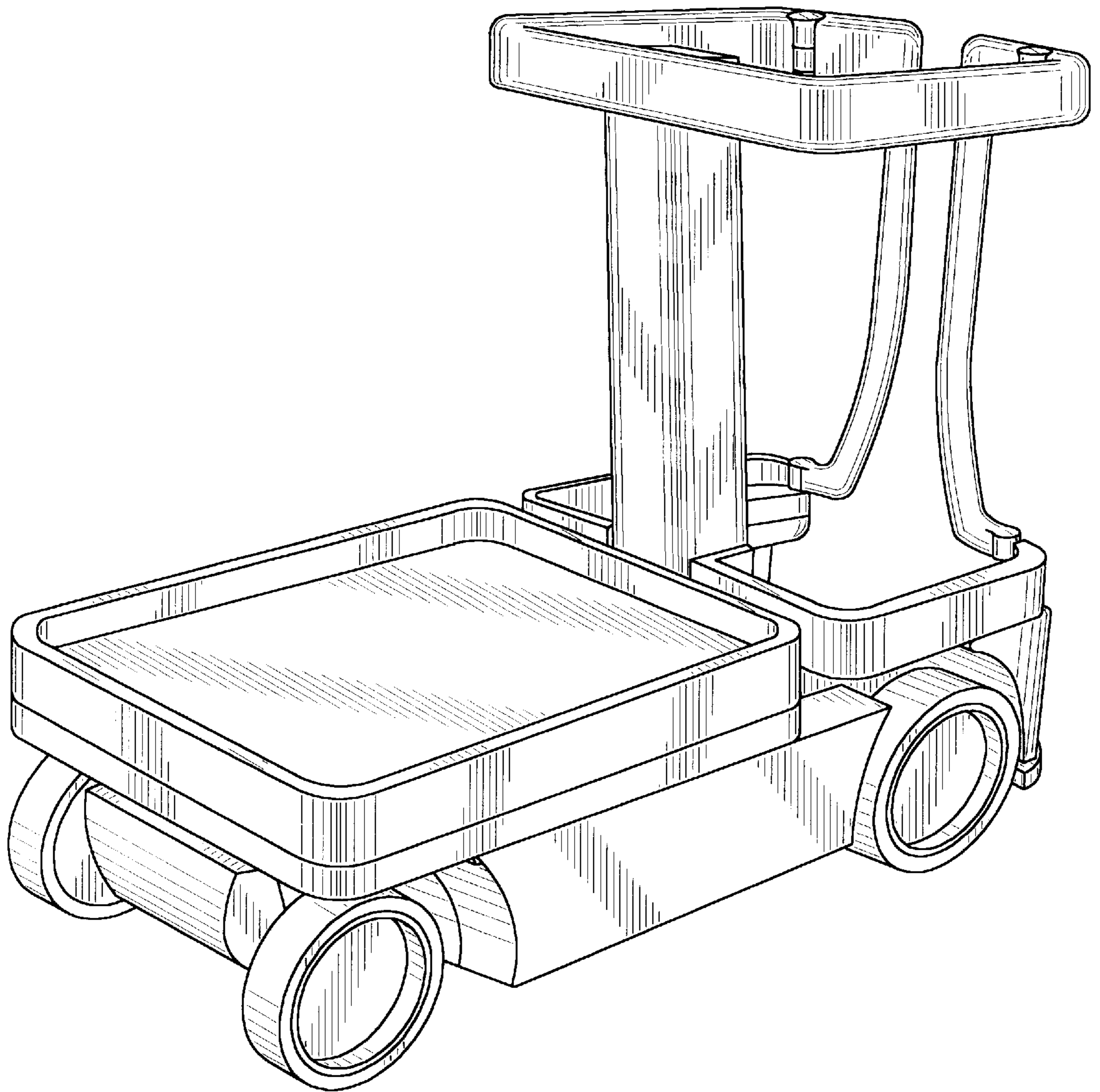

FIG. 1

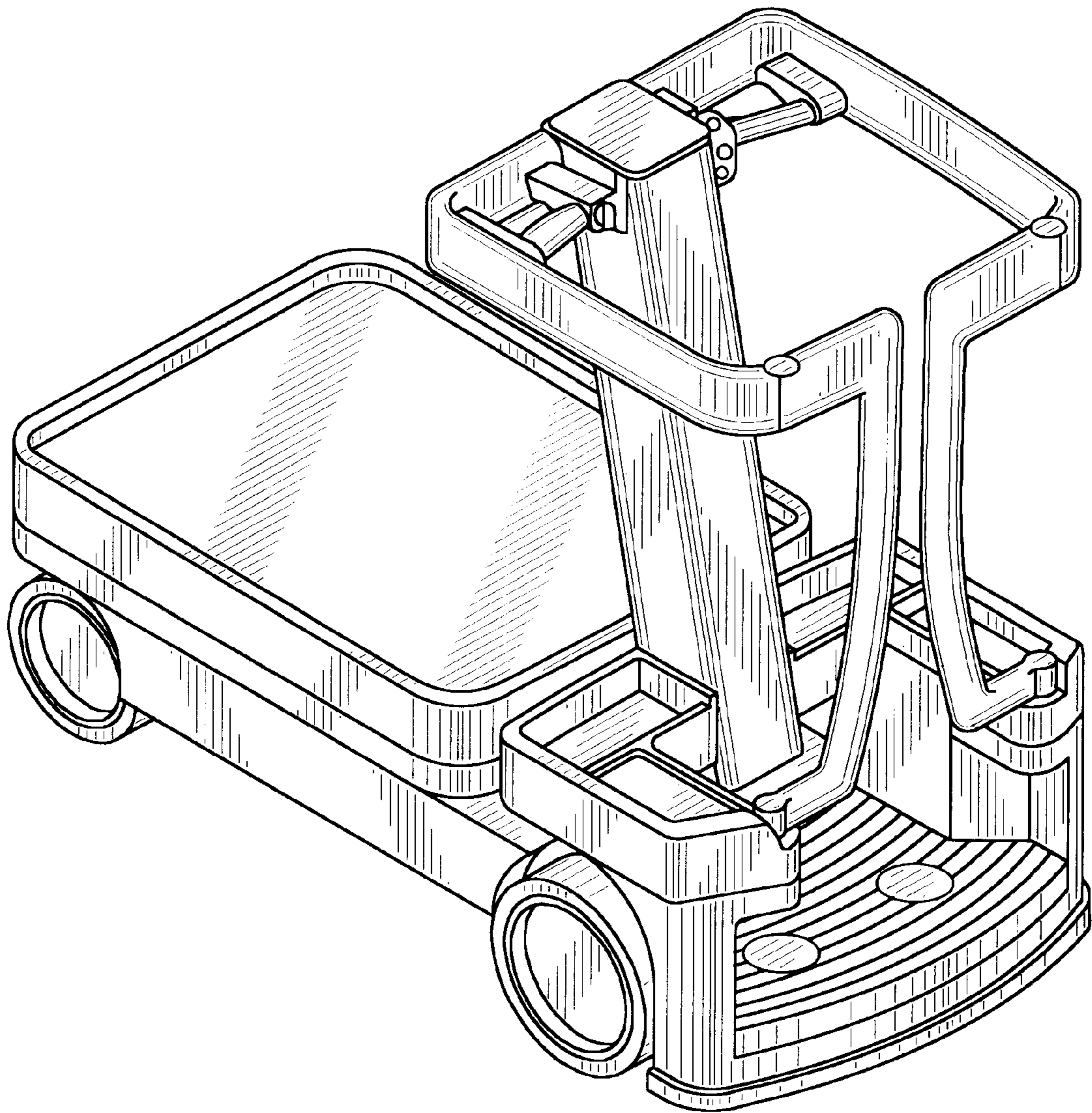

FIG. 2

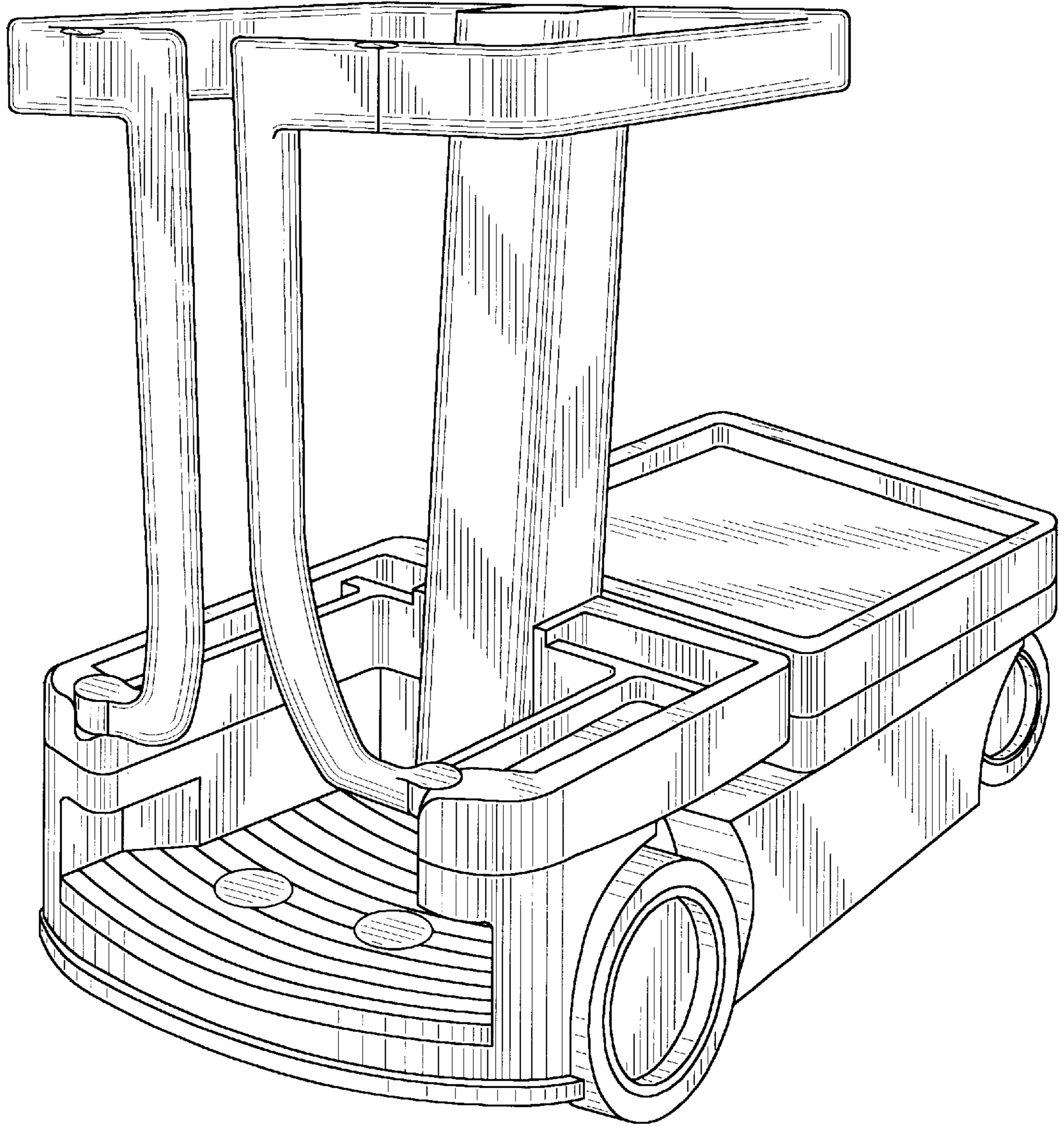

FIG. 3

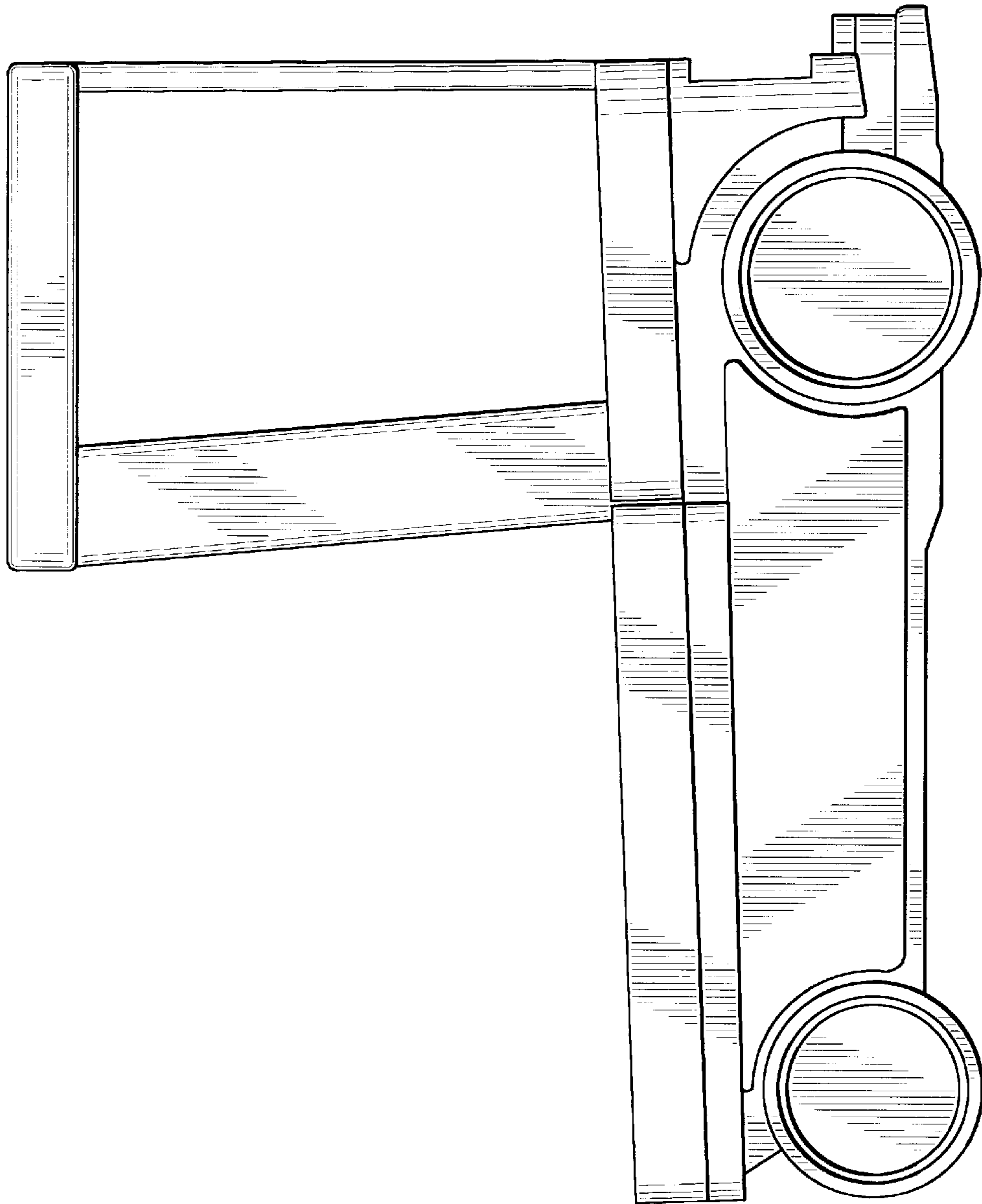

FIG. 4

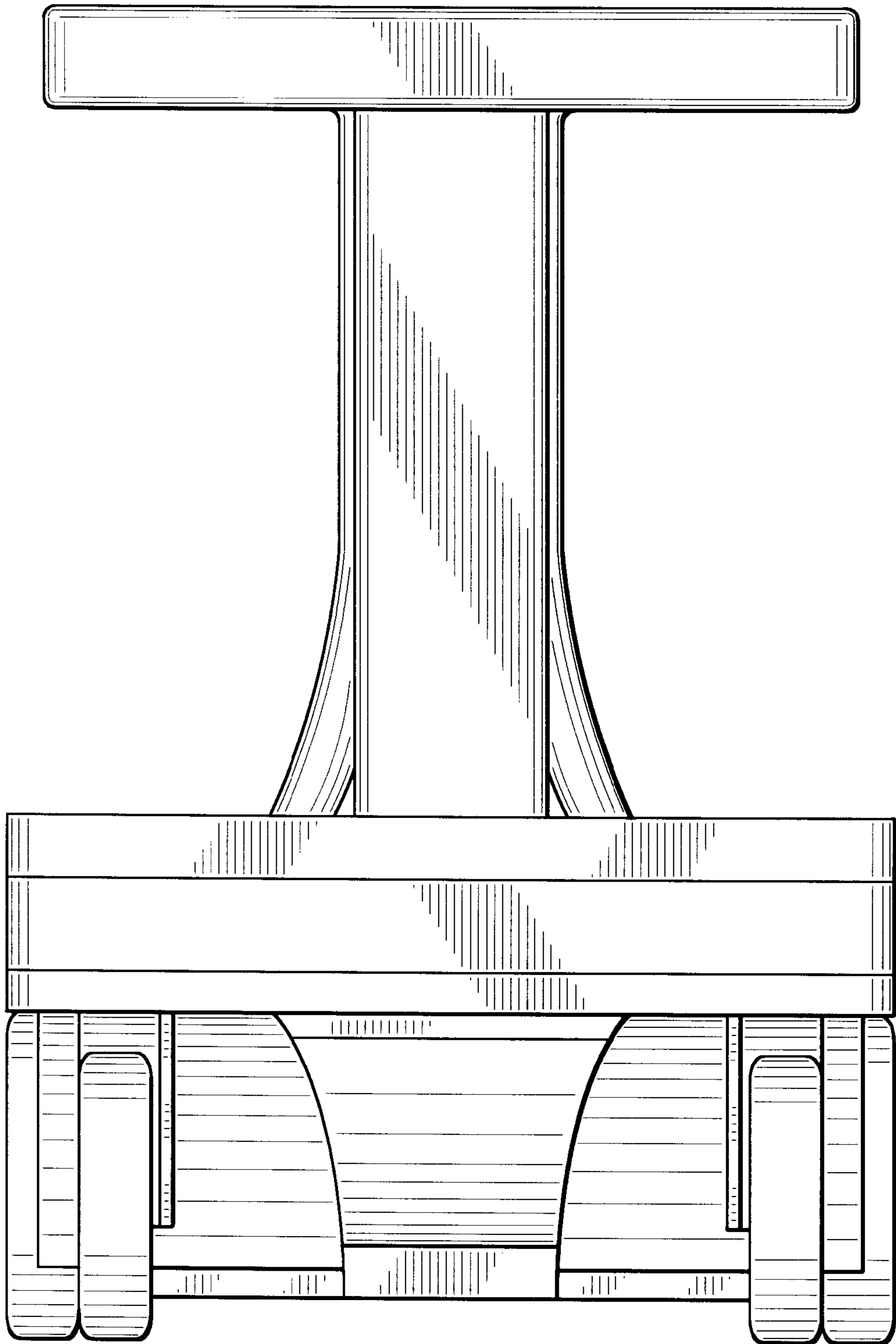

FIG. 5

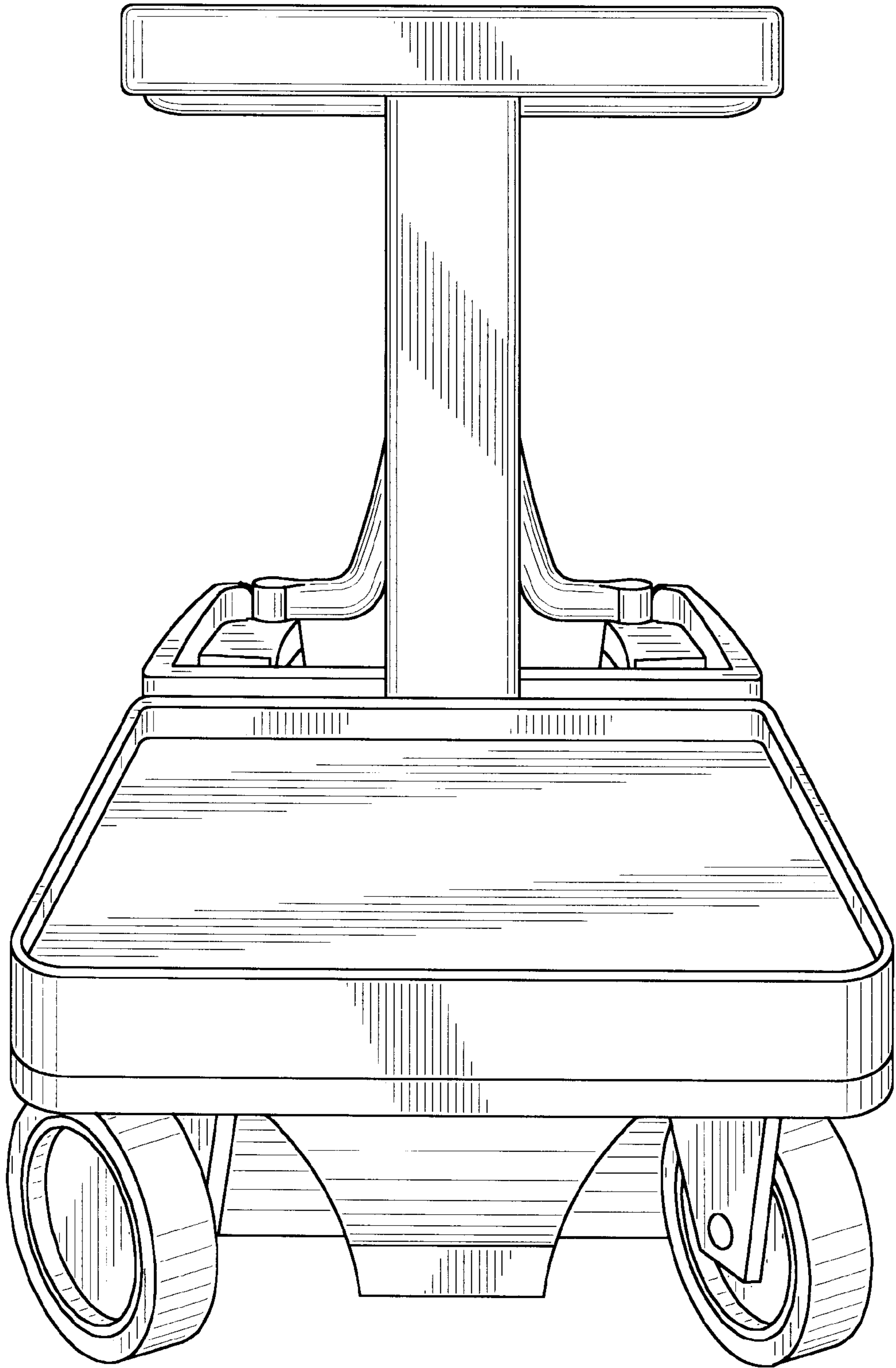

FIG. 6

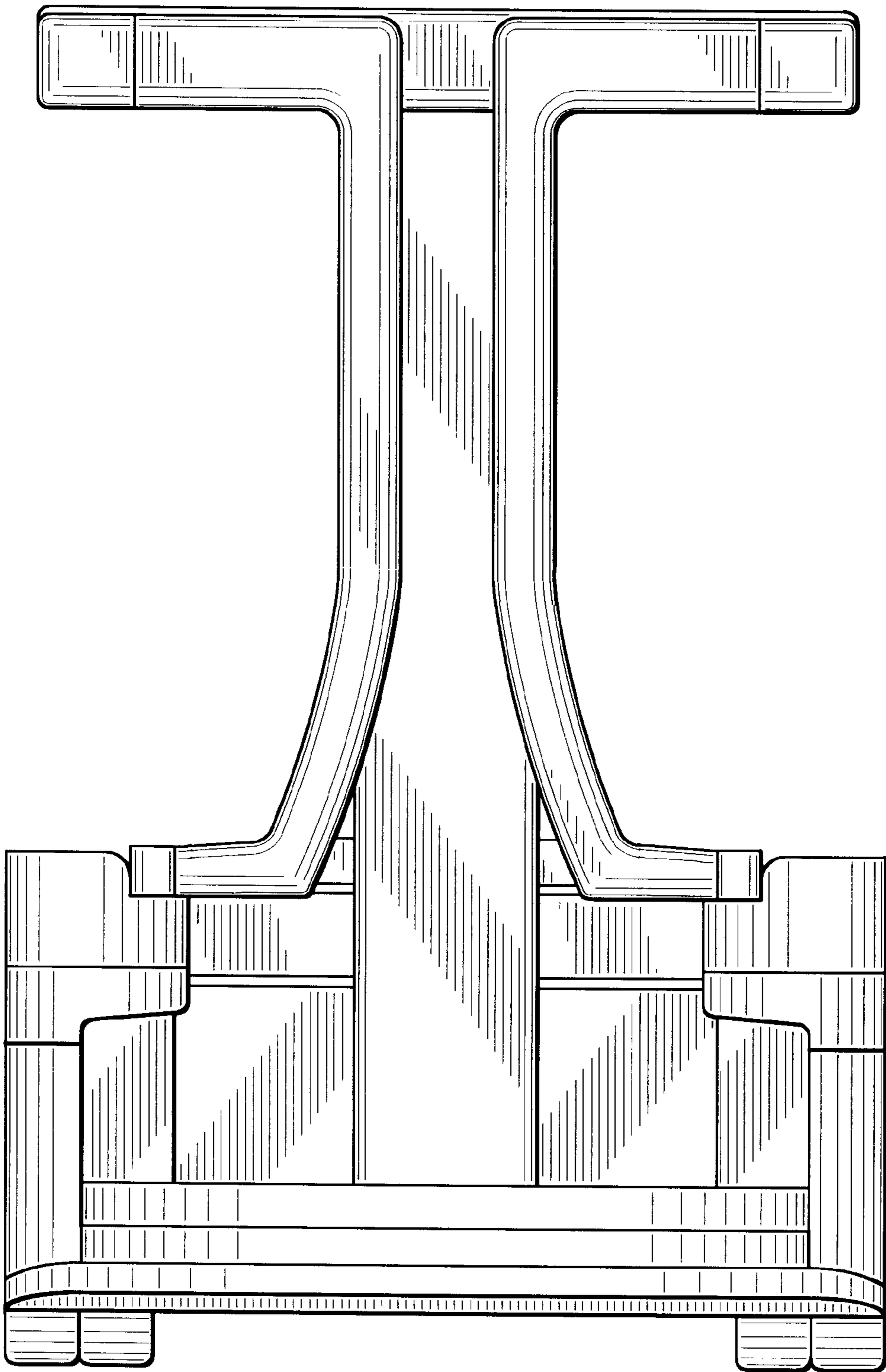

FIG. 7



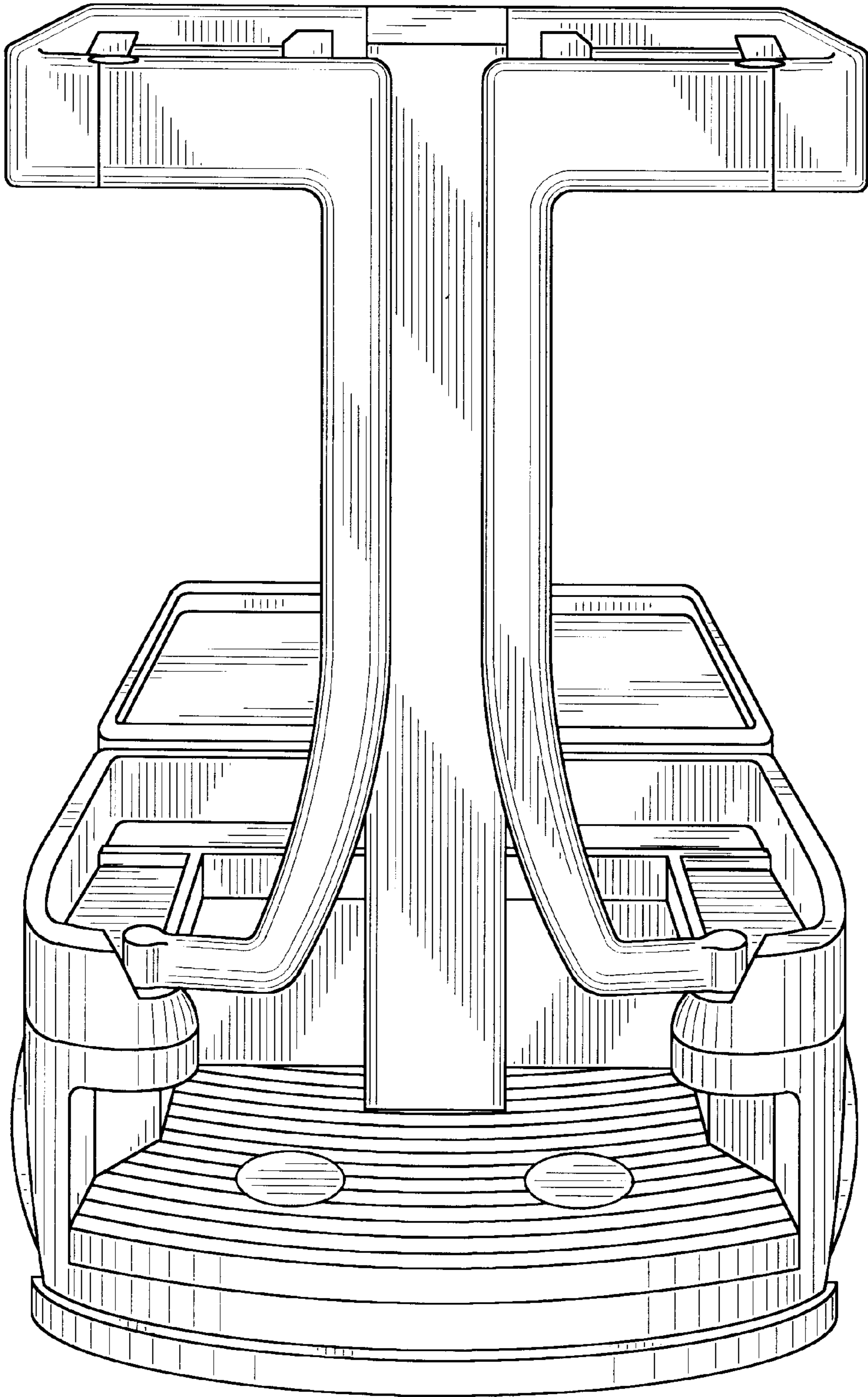

FIG. 8

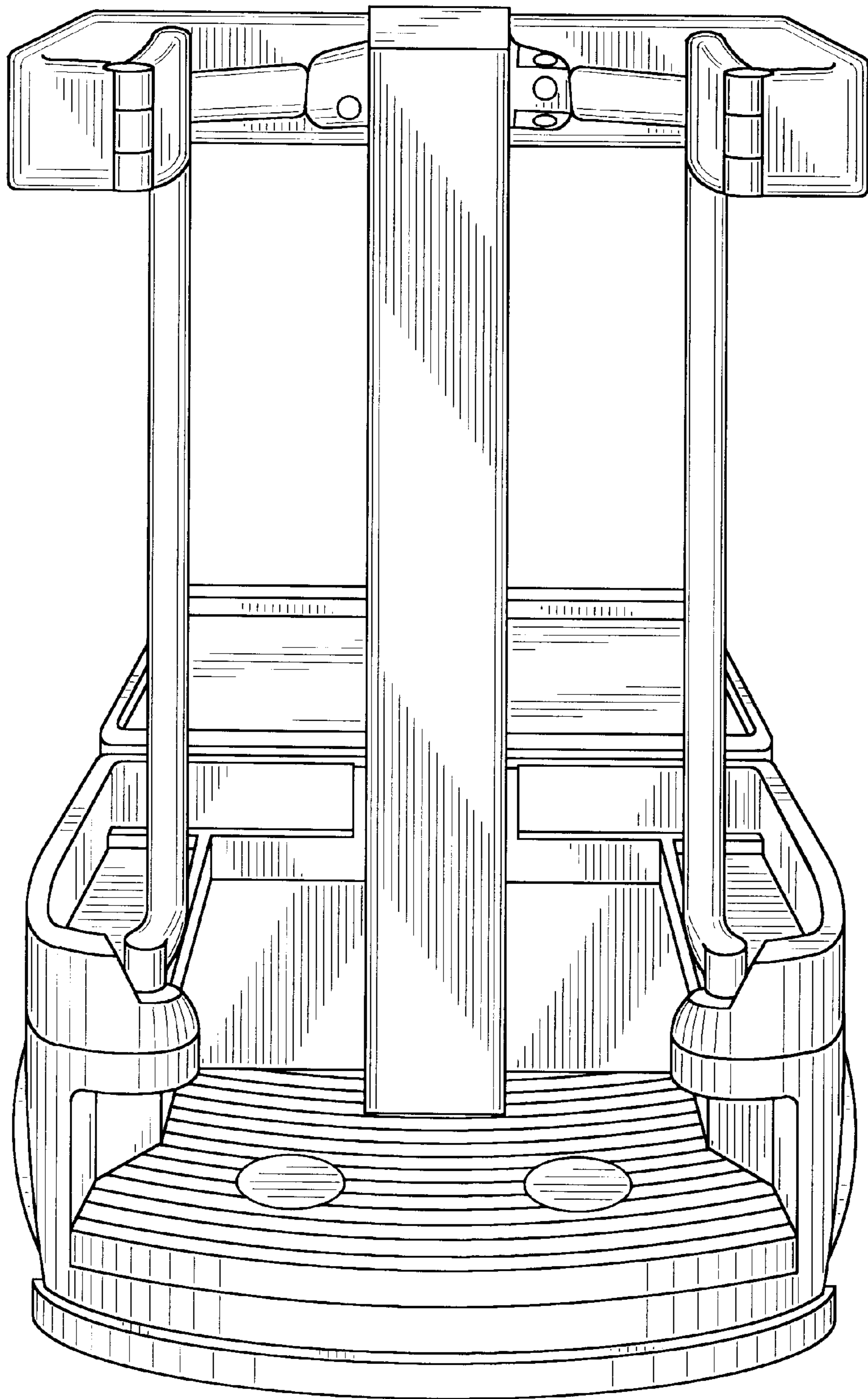

FIG. 9

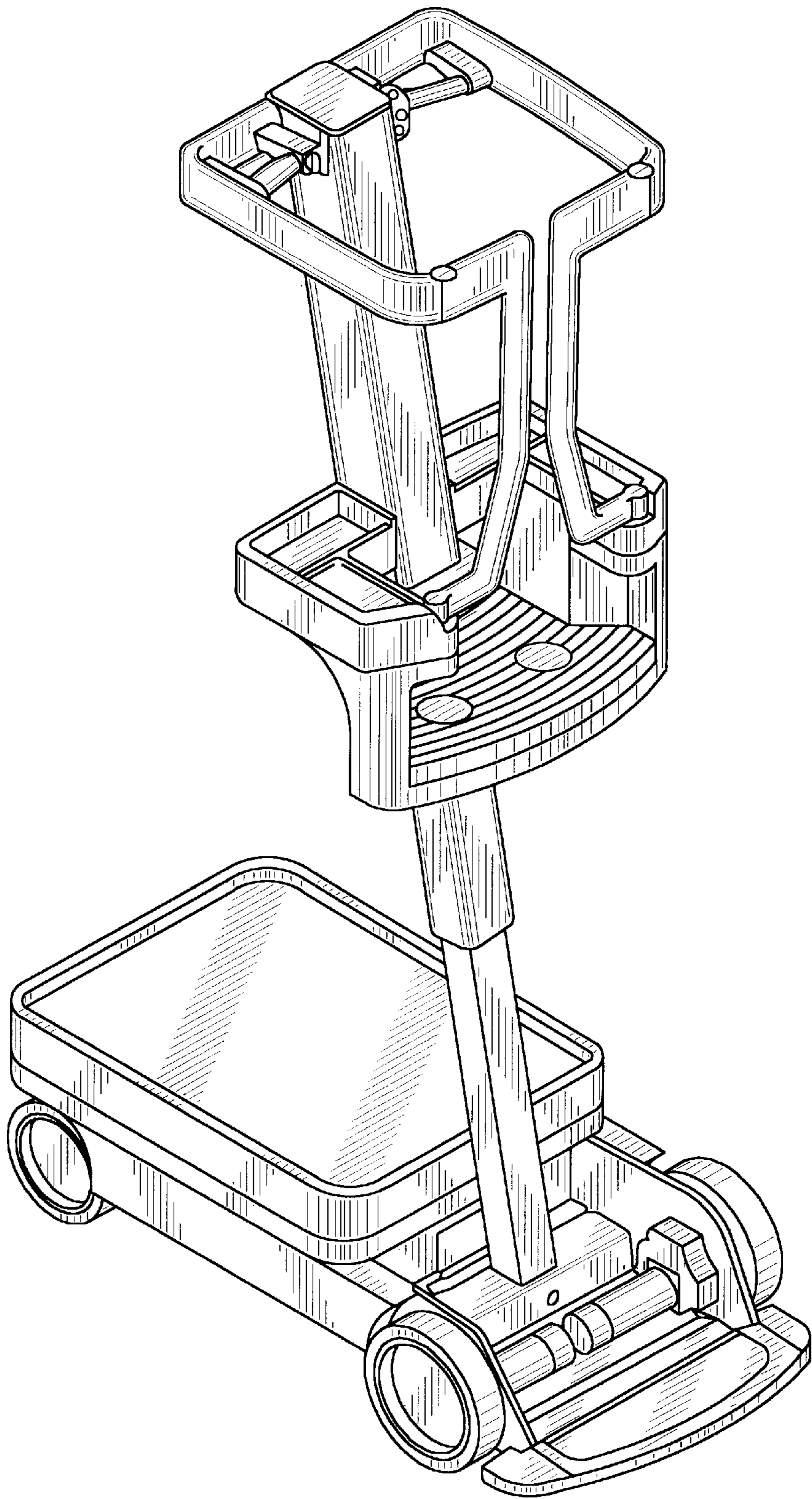

FIG. 10