



US00D412689S

United States Patent [19] Onopa

[11] **Patent Number: Des. 412,689**

[45] **Date of Patent: ** Aug. 10, 1999**

[54] **TRUCK HOOD**

[75] Inventor: **David P. Onopa**, Allentown, Pa.

[73] Assignee: **Mack Trucks, Inc.**, Allentown, Pa.

[**] Term: **14 Years**

[21] Appl. No.: **29/096,872**

[22] Filed: **Nov. 23, 1998**

[51] **LOC (6) Cl.** **12-16**

[52] **U.S. Cl.** **D12/173**

[58] **Field of Search** D12/173, 169,
D12/96, 97; 296/190

- D. 328,273 7/1992 McGrew, Jr. et al. .
- D. 335,272 5/1993 Allendorph et al. .
- D. 367,027 2/1996 Onopa .
- D. 399,791 10/1998 Hellhake et al. D12/96
- D. 403,636 1/1999 Meryman et al. D12/173

Primary Examiner—Melody N. Brown
Attorney, Agent, or Firm—Rothwell, Figg, Ernst & Kurz,
p.c.

[57] CLAIM

The ornamental design for a truck hood, as shown and described.

DESCRIPTION

FIG. 1 is a front elevation view of the truck hood, it being understood that the broken lines are for illustrative purposes only and form no part of the design.

FIG. 2 is a side elevation view of the embodiment shown in FIG. 1.

FIG. 3 is a top elevation view of the embodiment shown in FIG. 1; and,

FIG. 4 is a rear elevation view of the embodiment shown in FIG. 1.

[56] References Cited

U.S. PATENT DOCUMENTS

- D. 117,056 10/1939 Cadwallader .
- D. 117,493 11/1939 De Smet .
- D. 129,752 9/1941 Renno .
- D. 306,152 2/1990 Guelfi et al. .
- D. 306,421 3/1990 Allendorph et al. .
- D. 306,714 3/1990 Allendorph .
- D. 307,126 4/1990 Allendorph et al. .

1 Claim, 4 Drawing Sheets

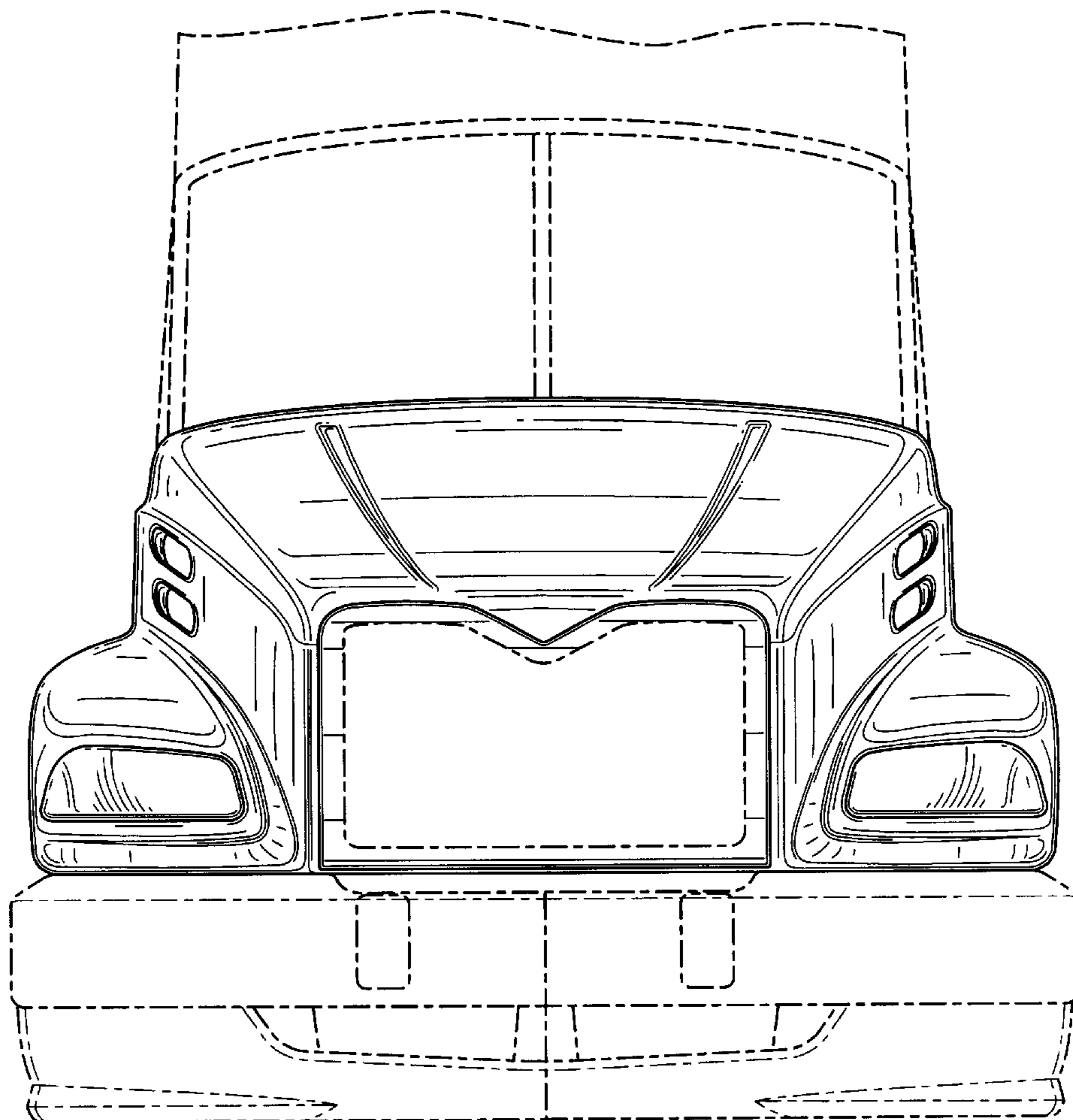
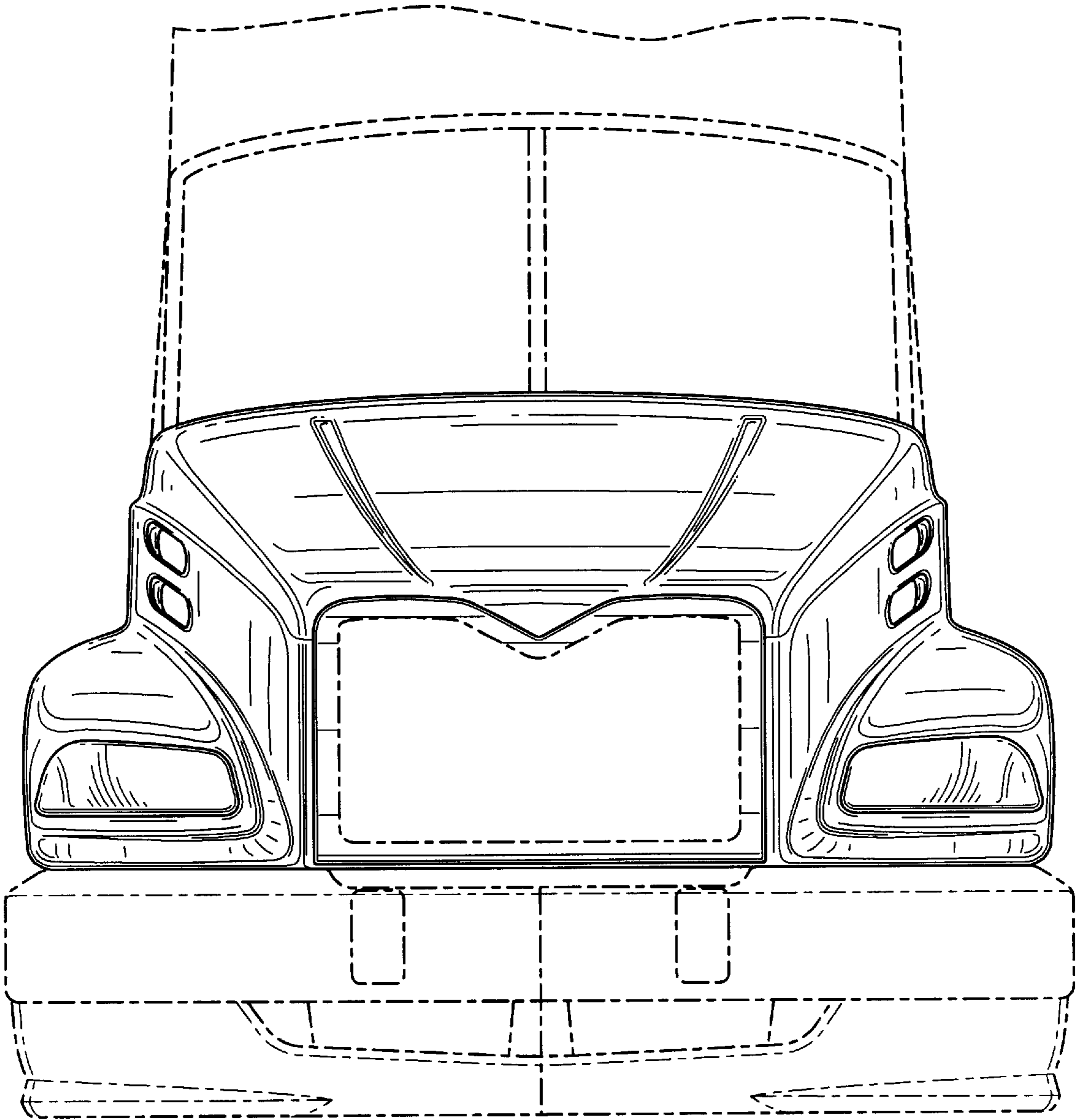

FIG. 1



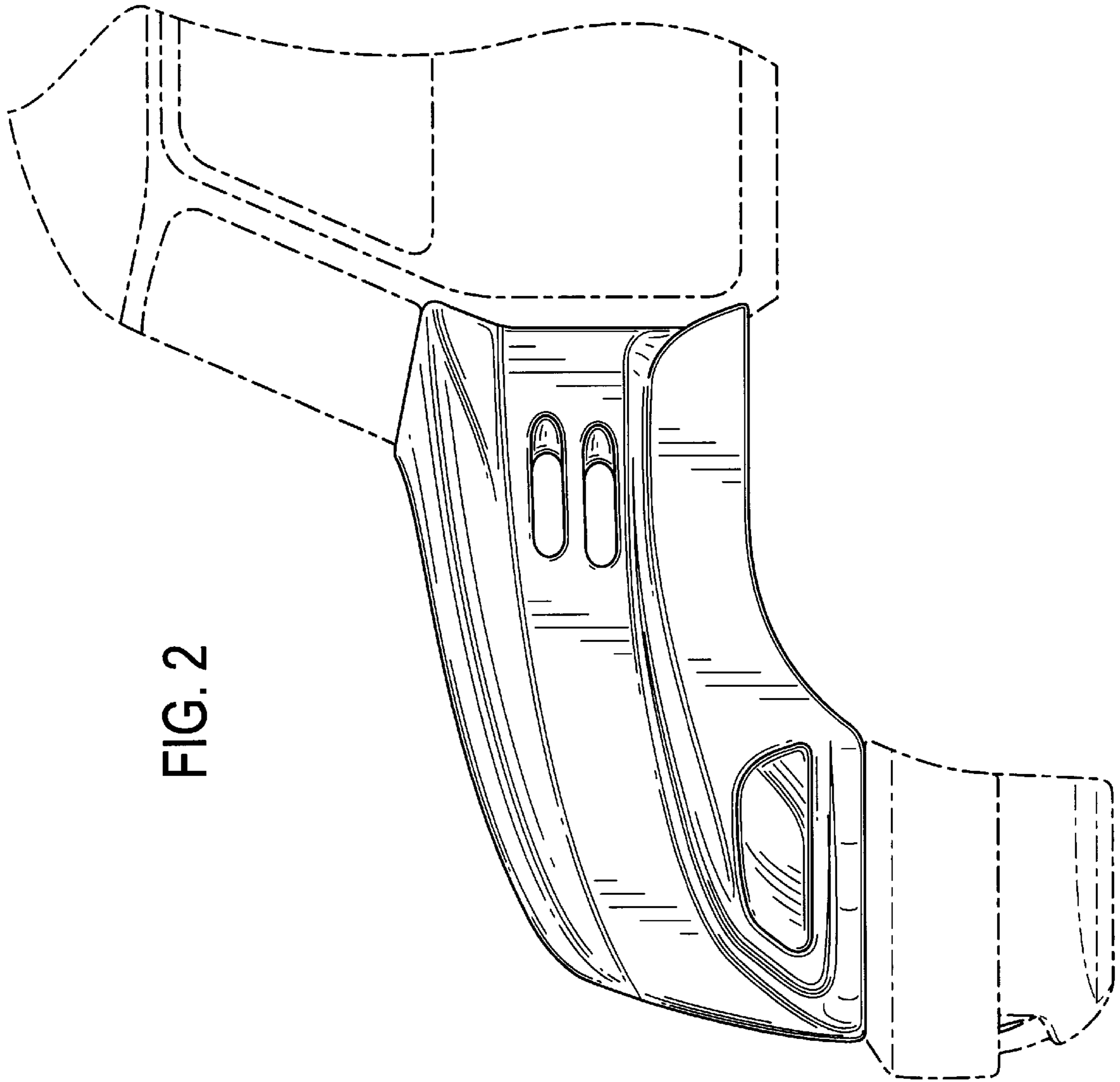
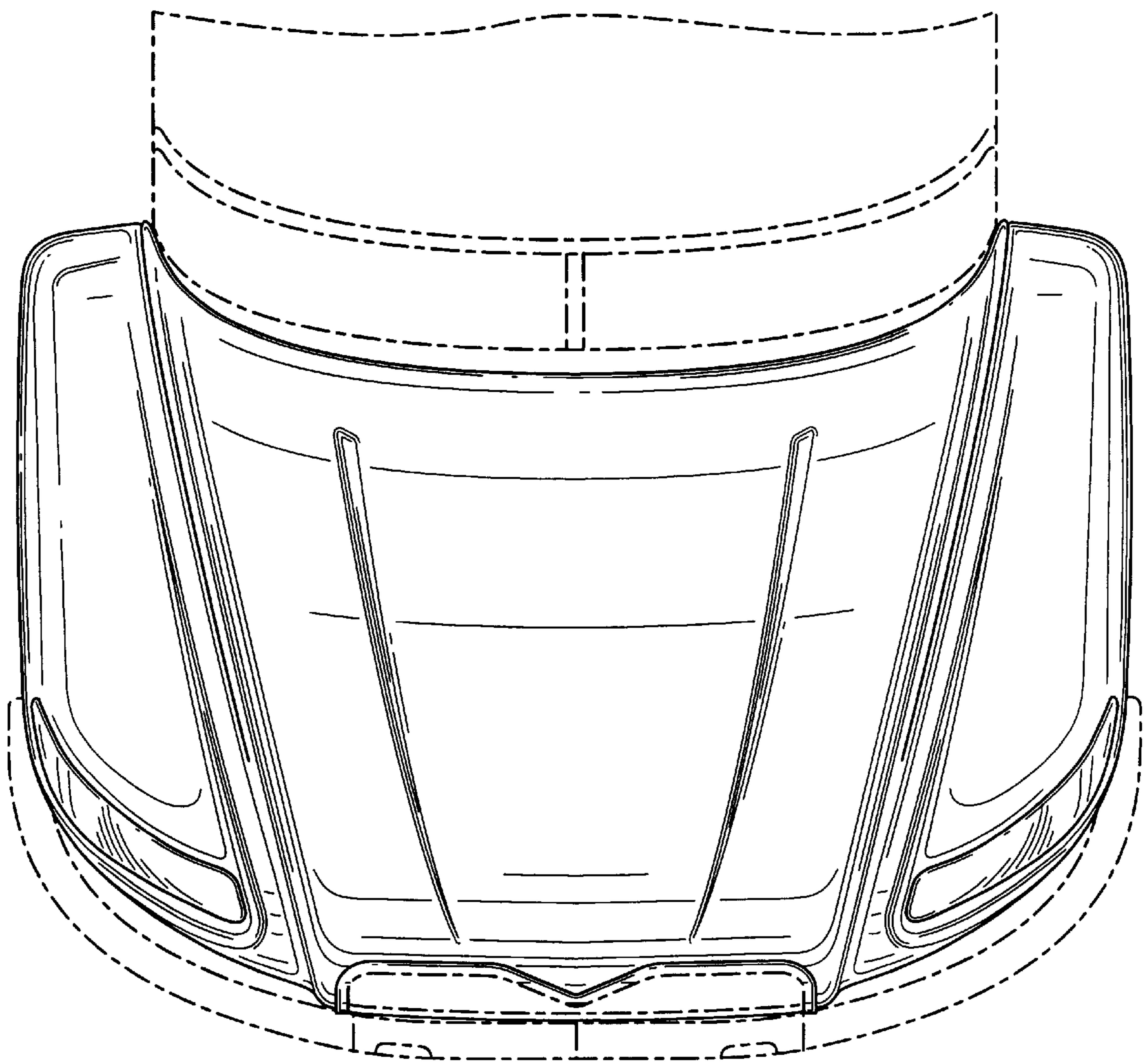

FIG. 2

FIG. 3



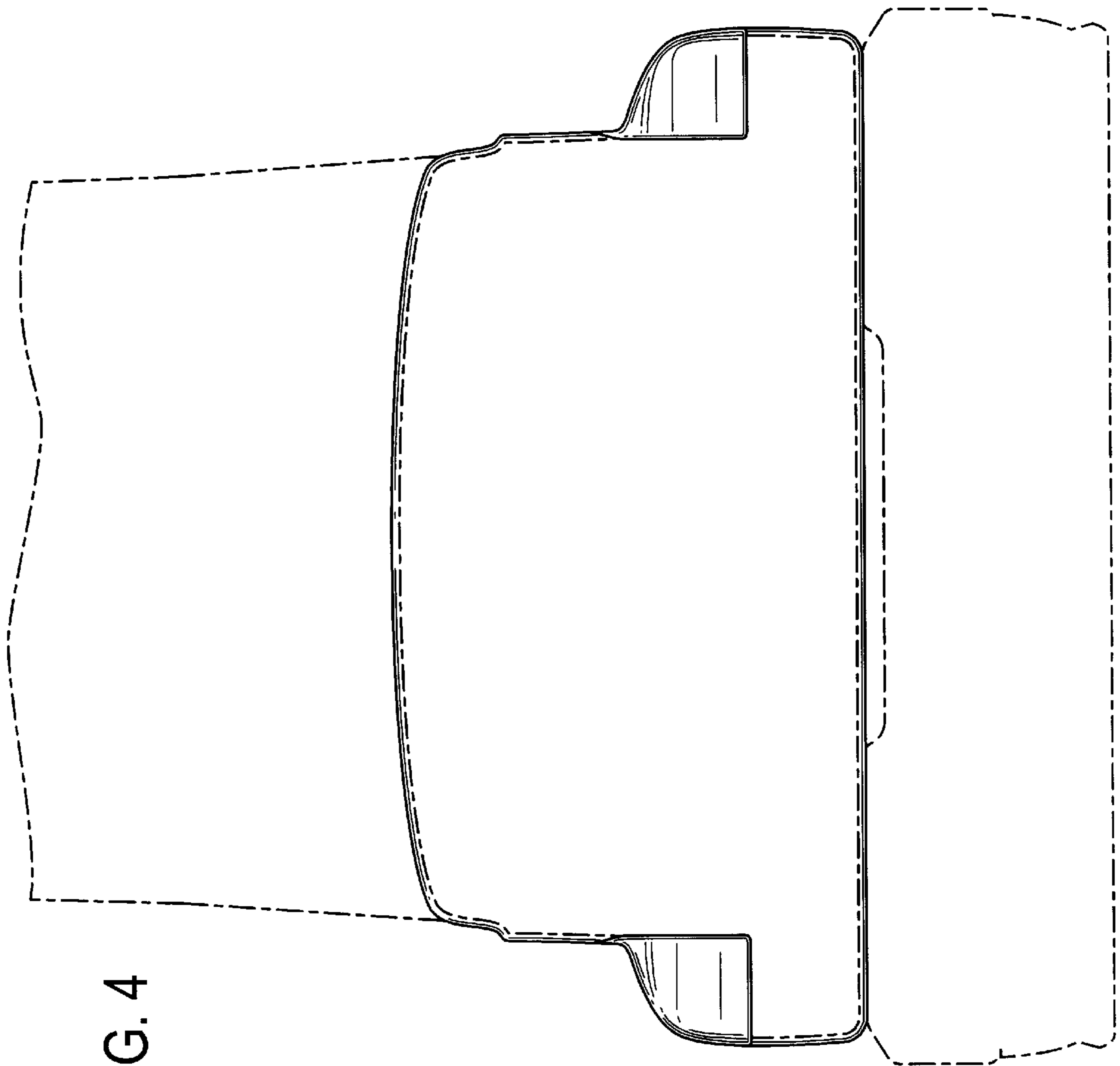

FIG. 4