



US00D412481S

United States Patent [19] Henry

[11] **Patent Number: Des. 412,481**

[45] **Date of Patent: ** Aug. 3, 1999**

[54] **WHEEL CHOCK**

[76] Inventor: **Stephen K. Henry**, 3825 Northbrook Dr., #F, Boulder, Colo. 80302

[**] Term: **14 Years**

[21] Appl. No.: **29/089,881**

[22] Filed: **Jun. 25, 1998**

D. 402,616	12/1998	Henry	D12/217
D. 404,001	1/1999	Henry	D12/217
D. 407,059	3/1999	Henry	D12/217
2,992,704	7/1961	Showker et al.	D12/217

Primary Examiner—Doris V. Coles
Assistant Examiner—Stacia Sinuik
Attorney, Agent, or Firm—Dorr, Carson, Sloan & Birney, P.C.

Related U.S. Application Data

[63] Continuation-in-part of application No. 29/066,614, Feb. 13, 1997, Pat. No. Des. 402,616.

[51] **LOC (6) Cl.** **12-06**

[52] **U.S. Cl.** **D12/217**

[58] **Field of Search** D12/114, 120, D12/217; 188/4 R, 32; 267/139, 140; 280/293; 410/30, 49

References Cited

U.S. PATENT DOCUMENTS

D. 223,771	6/1972	Roney, Jr.	D12/217
D. 315,542	3/1991	Dalton et al.	D12/217

[57] CLAIM

The ornamental design for a wheel chock, as shown and described.

DESCRIPTION

FIG. 1 is a front perspective view of a wheel chock showing my new design;
FIG. 2 is a top plan view of the wheel chock;
FIG. 3 is a front elevational view of the wheel chock, with the rear elevational view being a mirror image of FIG. 3;
FIG. 4 is left side elevational view of the wheel chock;
FIG. 5 is a right side elevational view of the wheel chock; and,
FIG. 6 is a bottom plan view of the wheel chock.

1 Claim, 3 Drawing Sheets

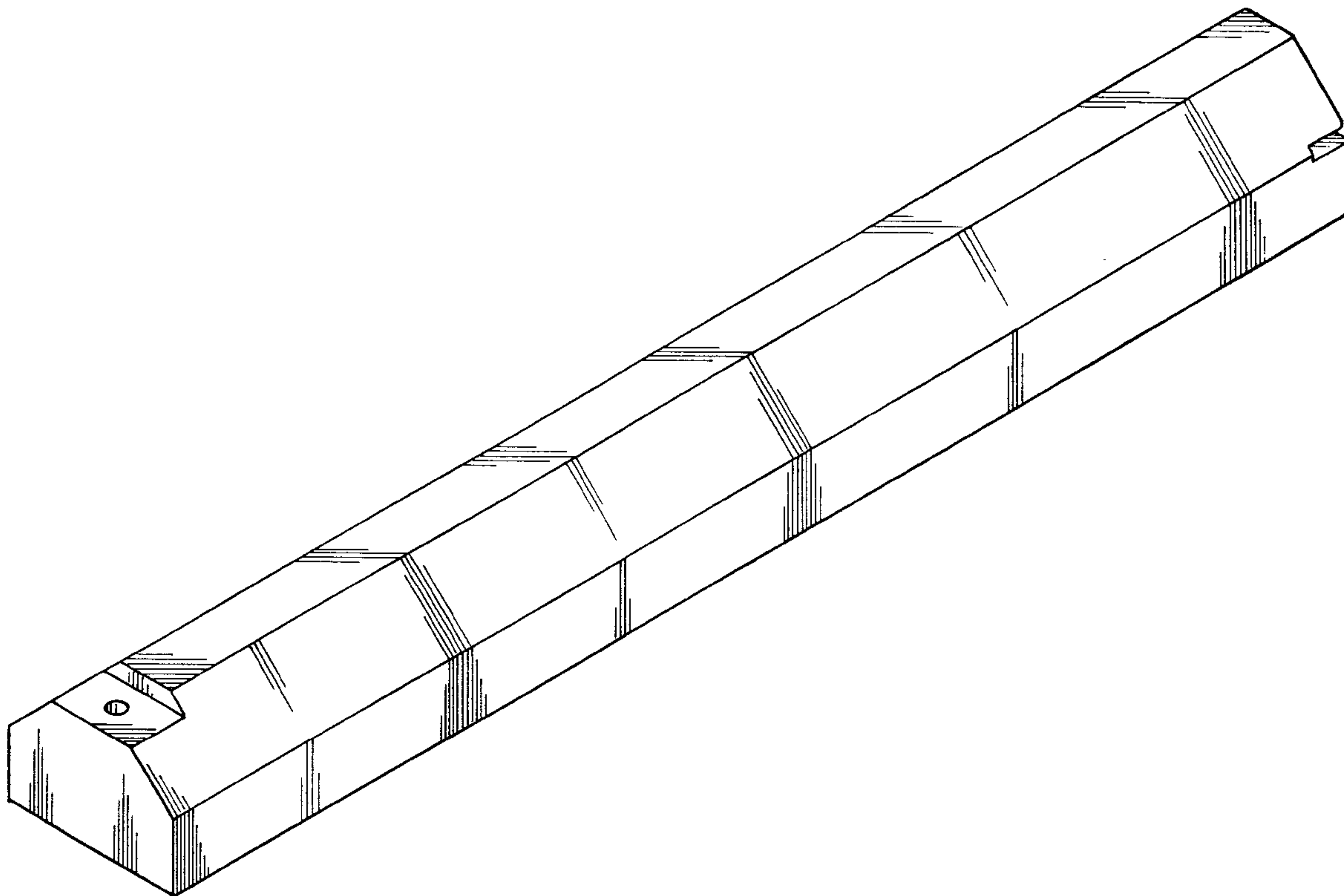

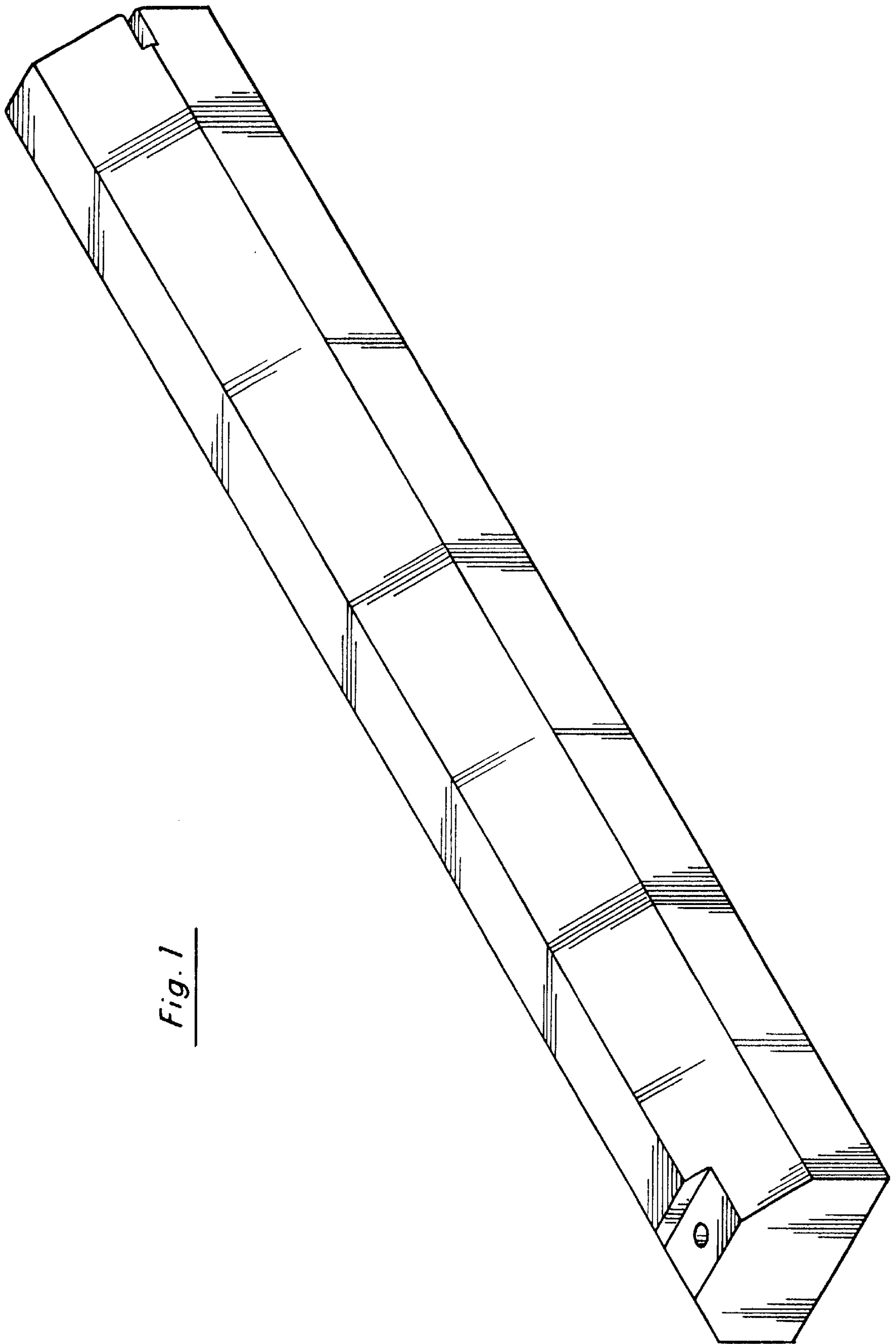

Fig. 1

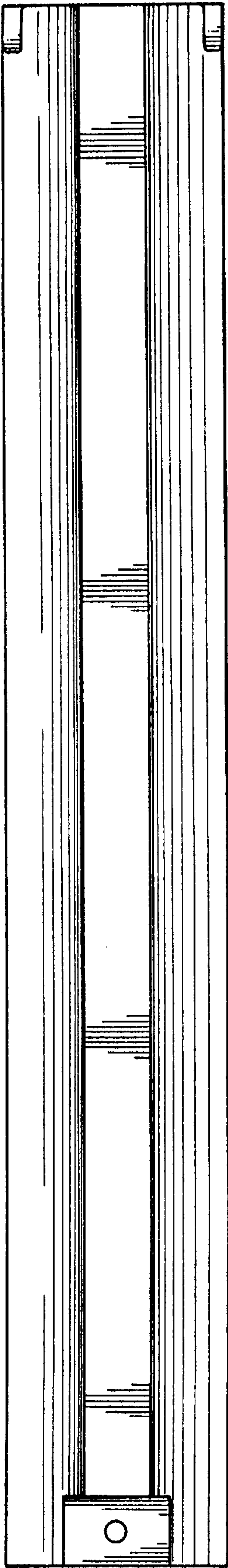

Fig. 2

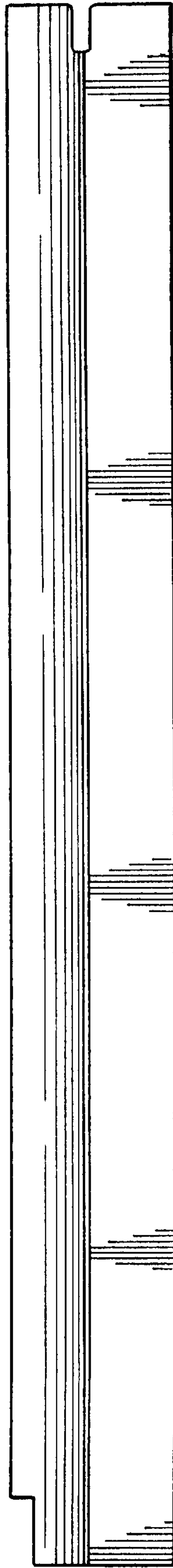

Fig. 3

Fig. 4

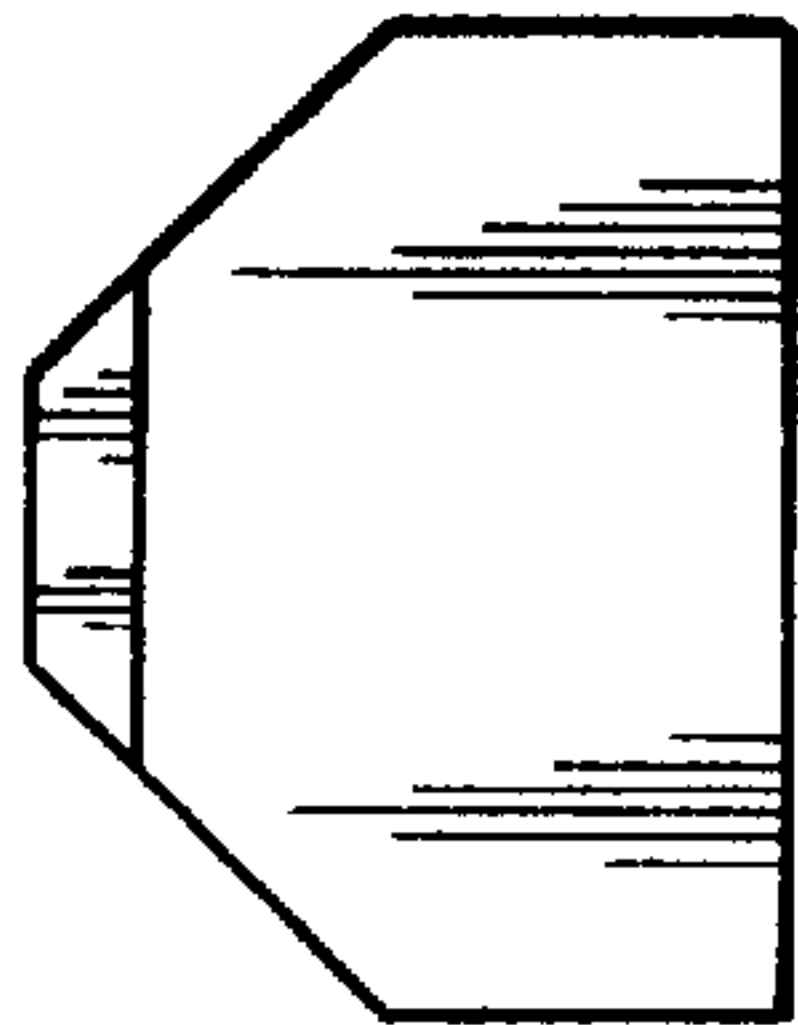

Fig. 5

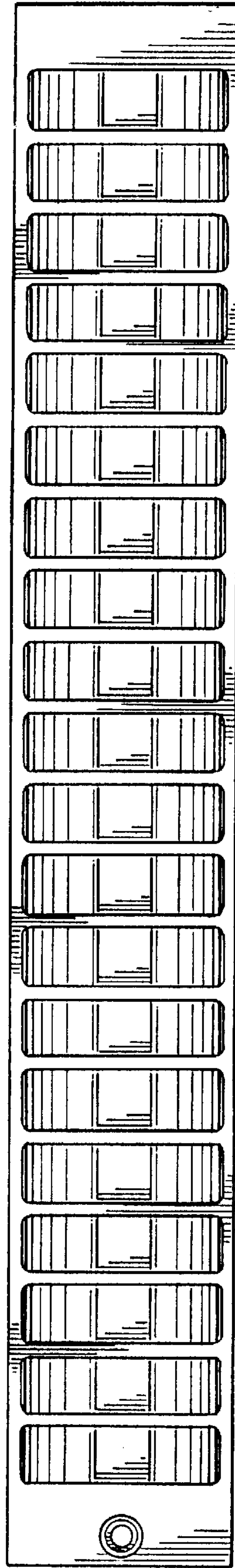
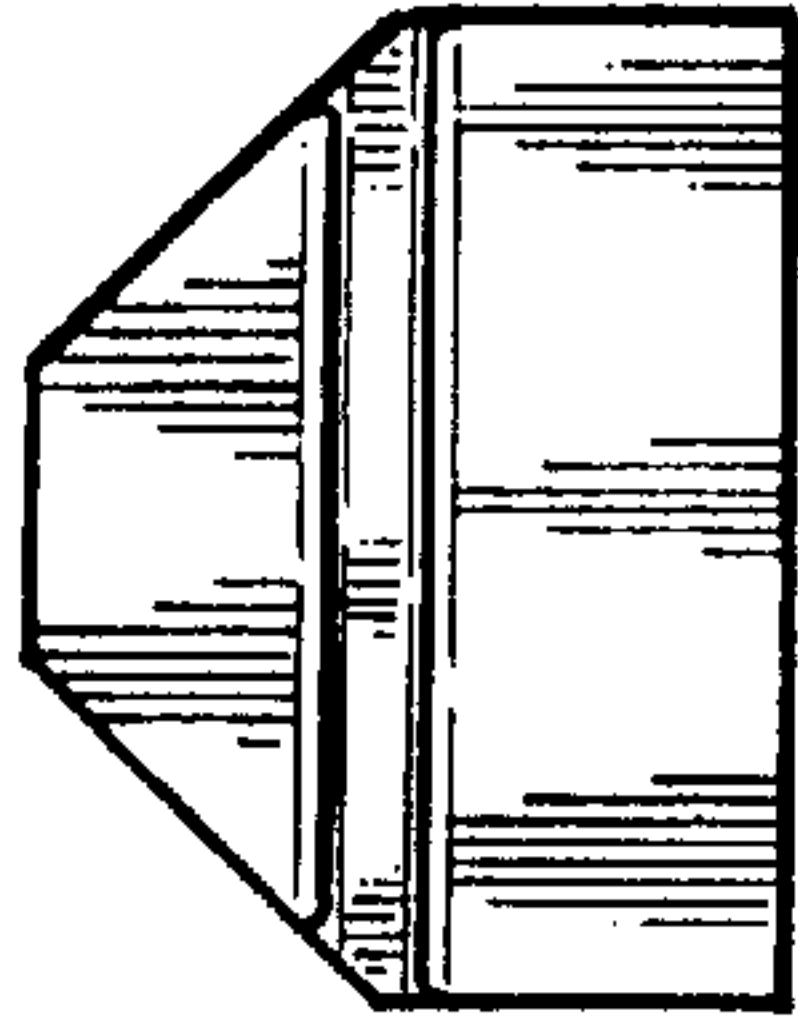

Fig. 6