



US00D412465S

# United States Patent [19] Patterson

[11] Patent Number: Des. 412,465

[45] Date of Patent: \*\* Aug. 3, 1999

[54] BICYCLE FRAME

[75] Inventor: Thomas C. Patterson, Westport, Conn.

[73] Assignee: Cannondale Corporation, Bethel, Conn.

[\*\*] Term: 14 Years

[21] Appl. No.: 29/054,800

[22] Filed: May 22, 1996

[51] LOC (6) Cl. .... 12-11

[52] U.S. Cl. .... D12/111

[58] Field of Search ..... D12/111; 280/281.1, 280/288.1-288.3

5,253,888 10/1993 Friedrich ..... 280/250.1  
5,456,481 10/1995 Allsop et al. .... 280/281.1  
5,464,240 11/1995 Robinson ..... 280/28.11

### OTHER PUBLICATIONS

Cannondale Catalog (1992).  
Cannondale Catalog (1993).  
Cannondale Catalog (1994).  
Cannondale Mid-Season Bicycles (1994).  
Cannondale Catalog (1995).

Primary Examiner—Melody N. Brown  
Attorney, Agent, or Firm—Pennie & Edmonds LLP

### [57] CLAIM

The ornamental design for a bicycle frame, as shown and described.

### [56] References Cited

#### U.S. PATENT DOCUMENTS

Re. 33,295	8/1990	Trimble	280/281.1
D. 239,824	5/1976	Marsee	D12/111
D. 321,155	10/1991	Tan	D12/111
D. 323,477	1/1992	Peart et al.	D12/111
D. 327,040	6/1992	Brummer	D12/111
D. 357,651	4/1995	Isaac et al.	D12/111
D. 371,093	6/1996	Allsop et al.	D12/111
3,533,643	10/1970	Yamada	280/281.1
4,067,589	1/1978	Hon	280/278
4,548,422	10/1985	Michel	280/281.1
4,550,927	11/1985	Resele	280/281.1
4,593,929	6/1986	Williams	280/650
4,850,607	7/1989	Trimble	280/281.1
4,865,337	9/1989	Disler et al.	280/7.1
4,889,355	12/1989	Trimble	280/281.1
4,923,203	5/1990	Trimble et al.	280/288.3
5,011,172	4/1991	Bellanca et al.	280/281.1
5,092,614	3/1992	Malewicz	280/11.22

### DESCRIPTION

FIG. 1 is a side perspective view of my new design for a bicycle frame;  
FIG. 2 is a rear perspective view thereof;  
FIG. 3 is a front perspective view thereof;  
FIG. 4 is a side elevational view thereof;  
FIG. 5 is an opposite side elevational view thereof;  
FIG. 6 is a rear elevational view thereof;  
FIG. 7 is a front elevational view thereof;  
FIG. 8 is a bottom plan view thereof;  
FIG. 9 is a top plan view thereof;  
FIG. 10 is a side perspective view of a second embodiment of my new design for a bicycle frame;  
FIG. 11 is a rear perspective view of FIG. 10;  
FIG. 12 is a front perspective view of FIG. 10;  
FIG. 13 is a side elevational view of FIG. 10 thereof; and,  
FIG. 14 is an opposite side elevational view of FIG. 10.

1 Claim, 12 Drawing Sheets

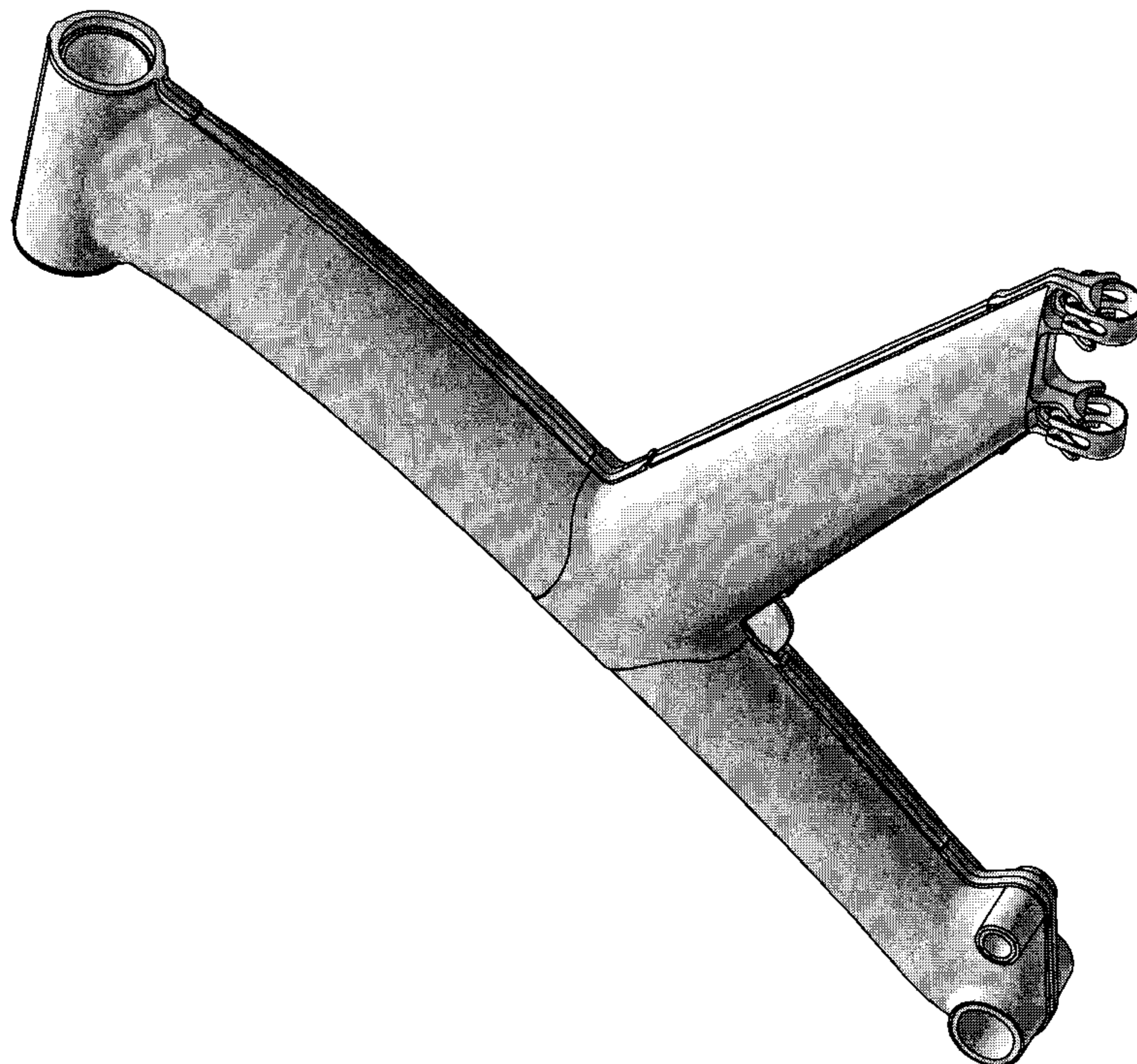

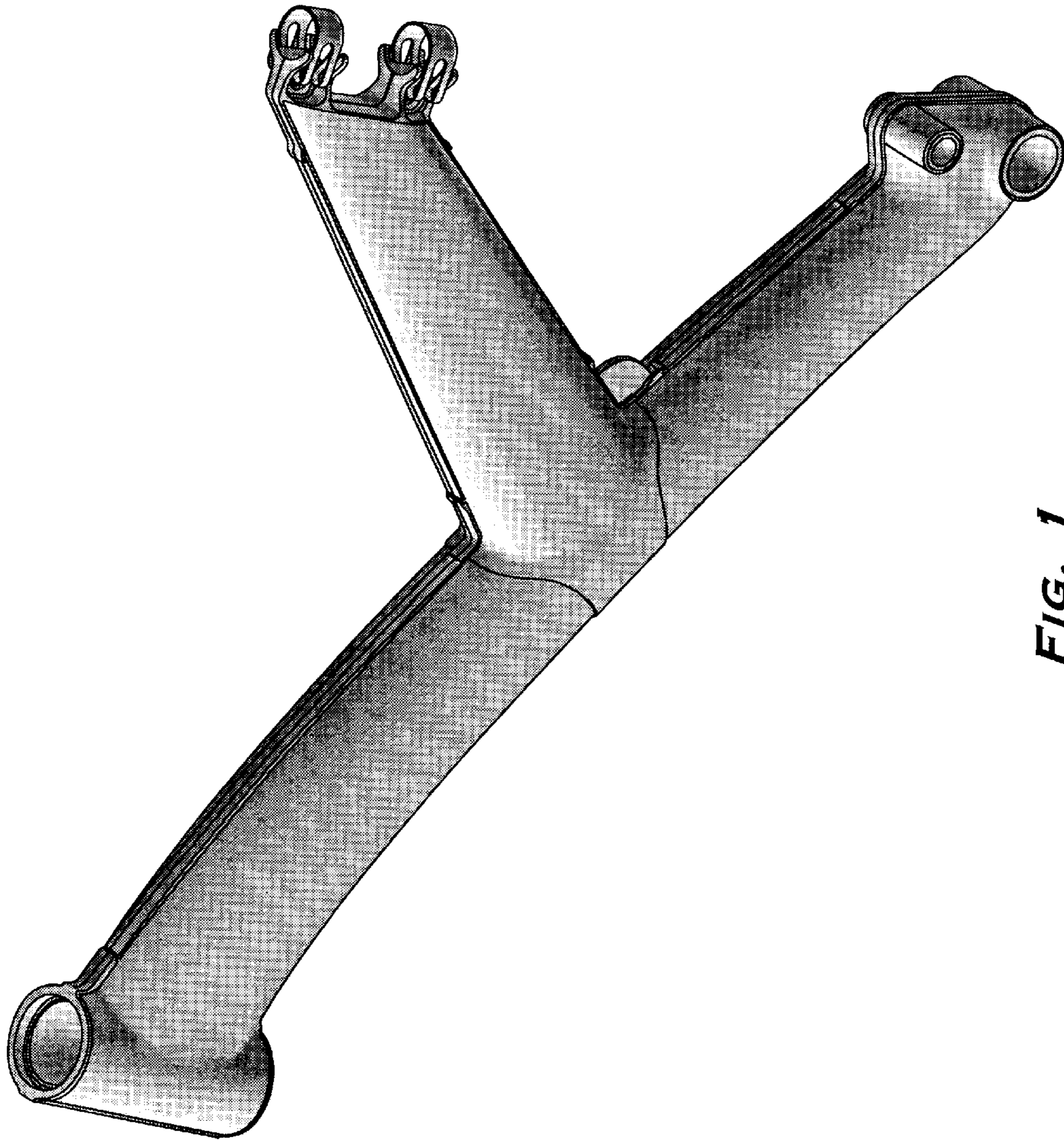

*FIG. 1*

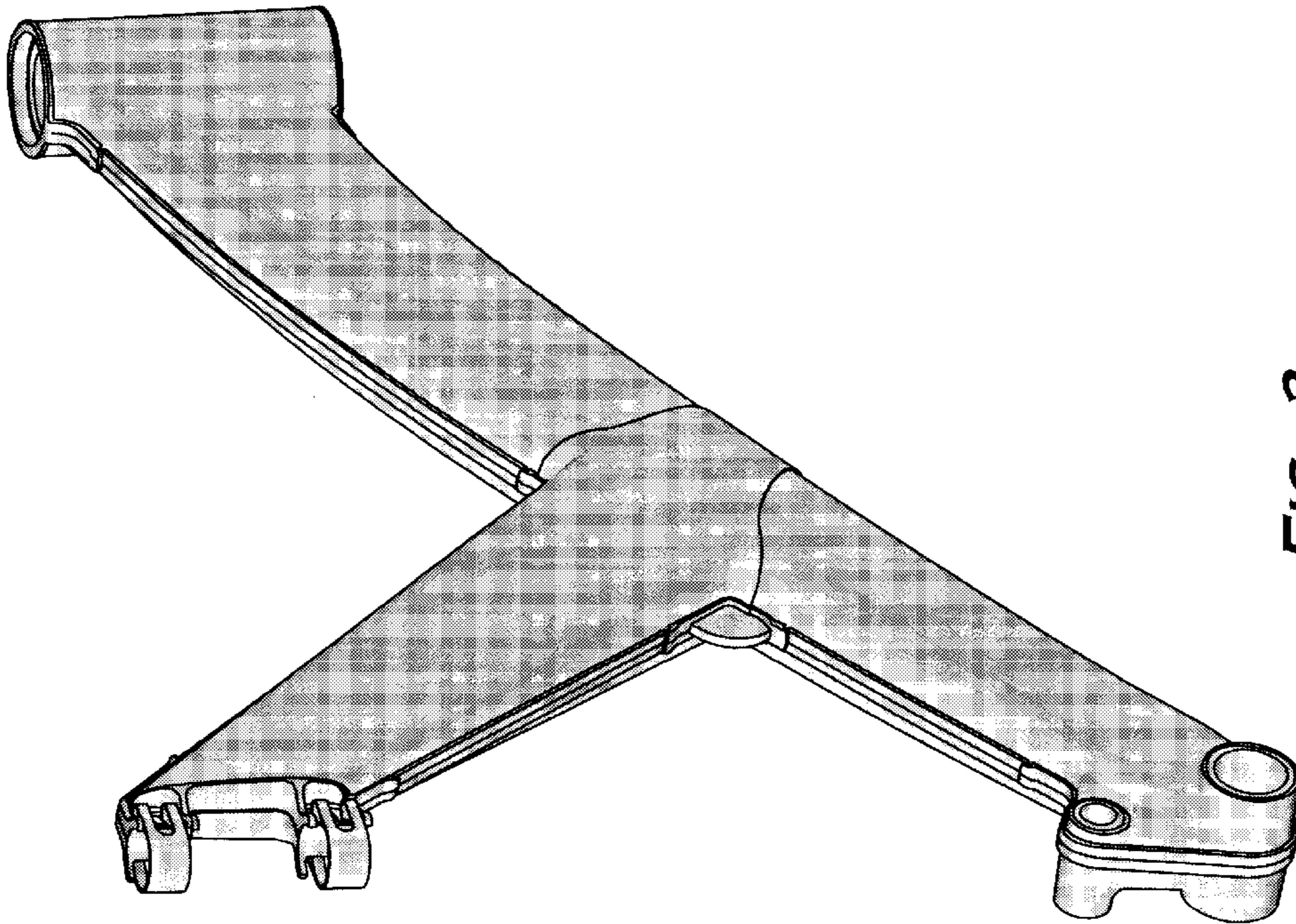

**FIG. 2**

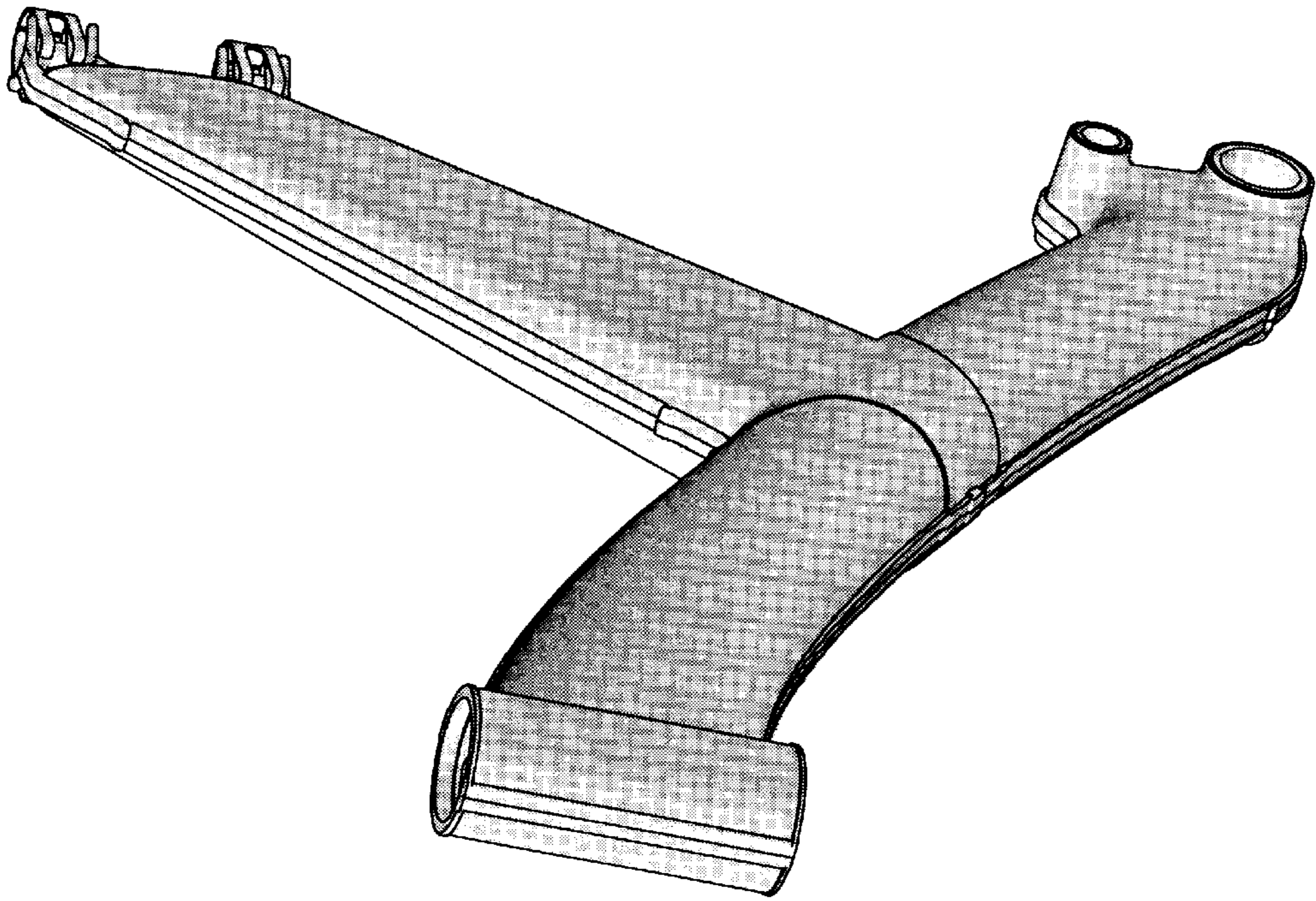
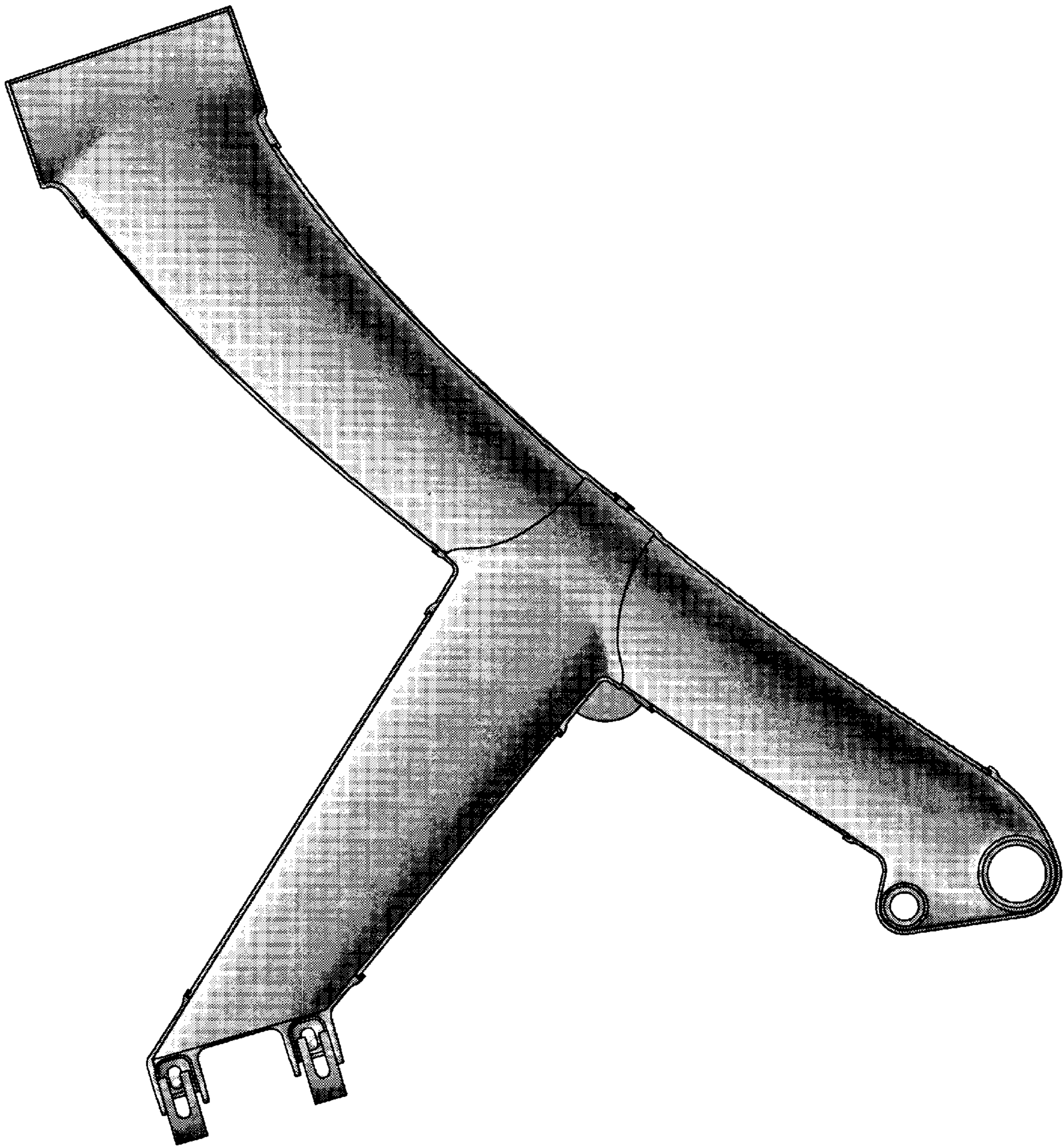

FIG. 3



*FIG. 4*

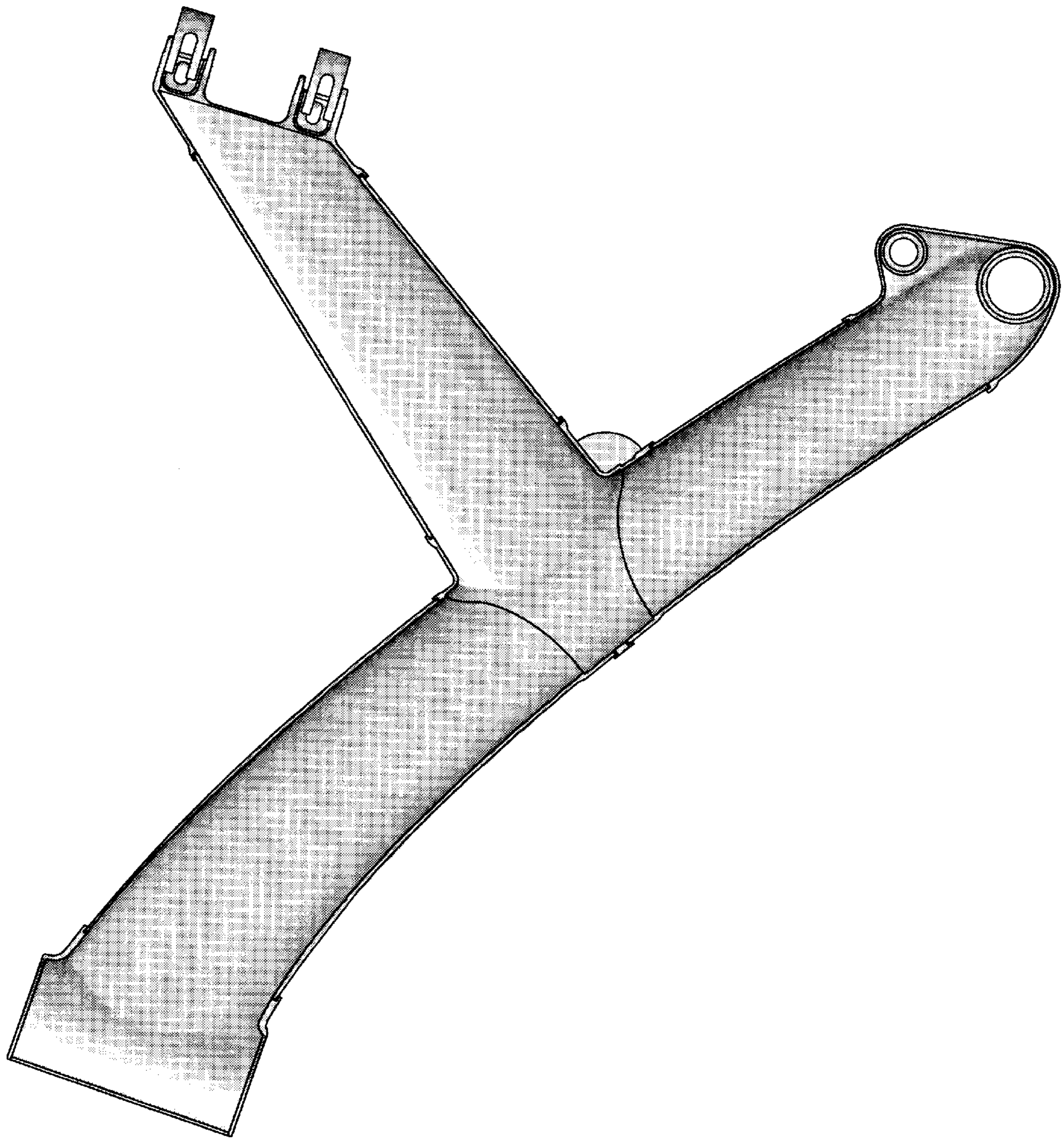

FIG. 5

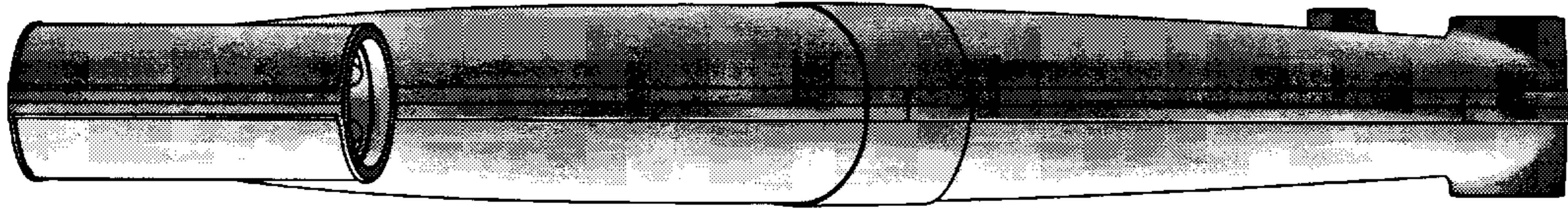

FIG. 7

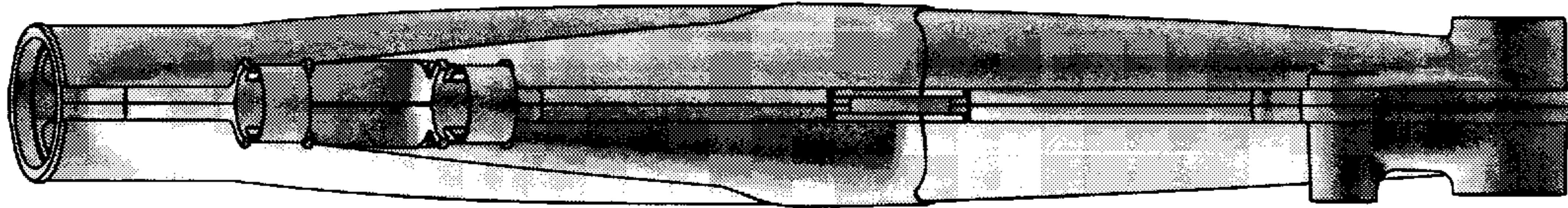

FIG. 6

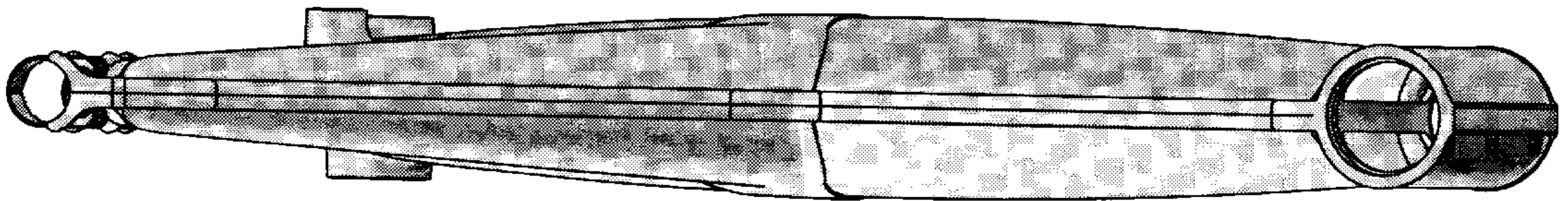

FIG. 9

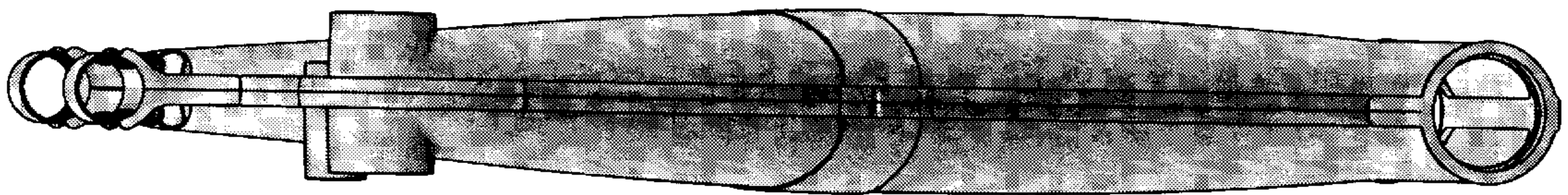
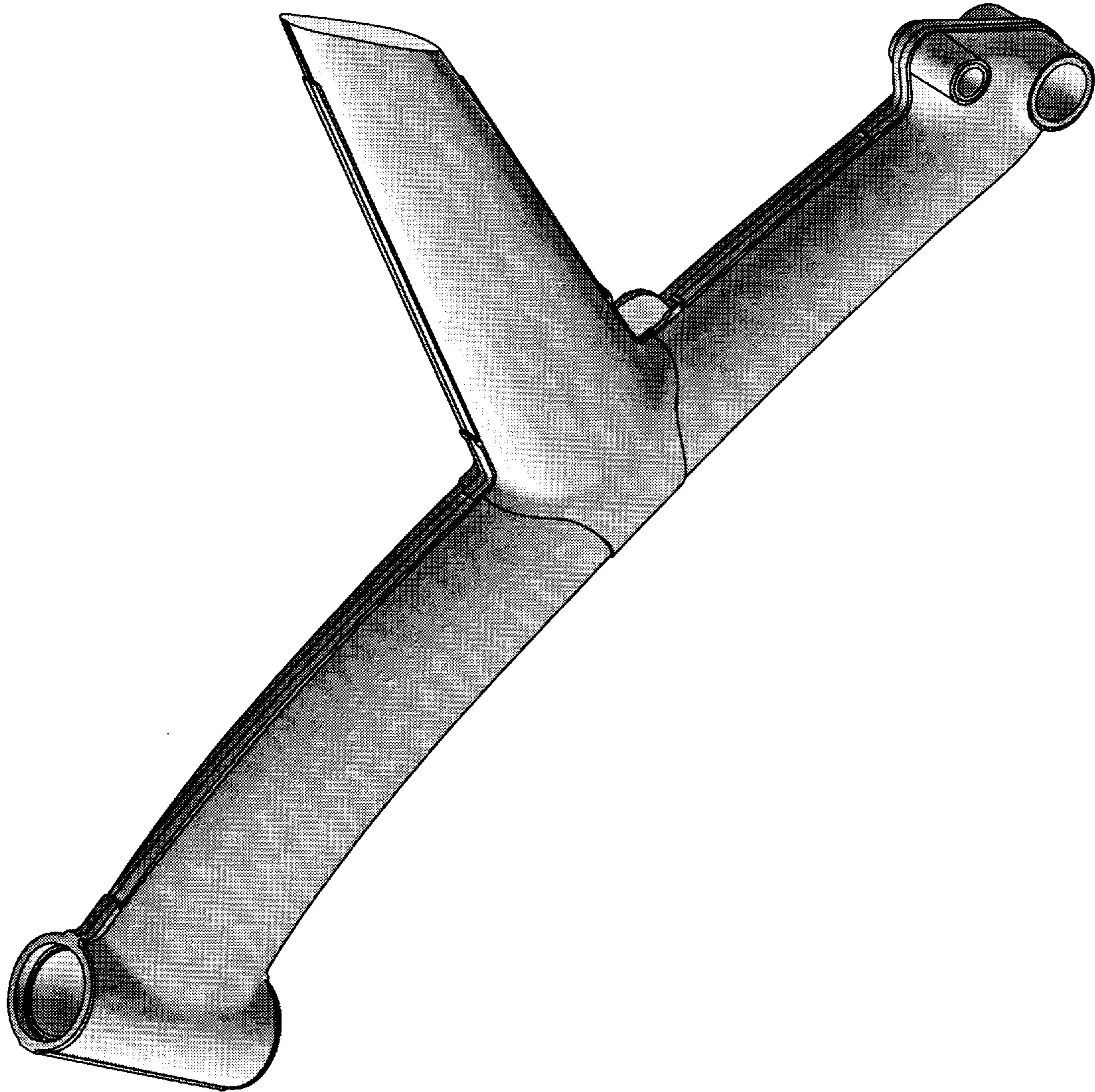
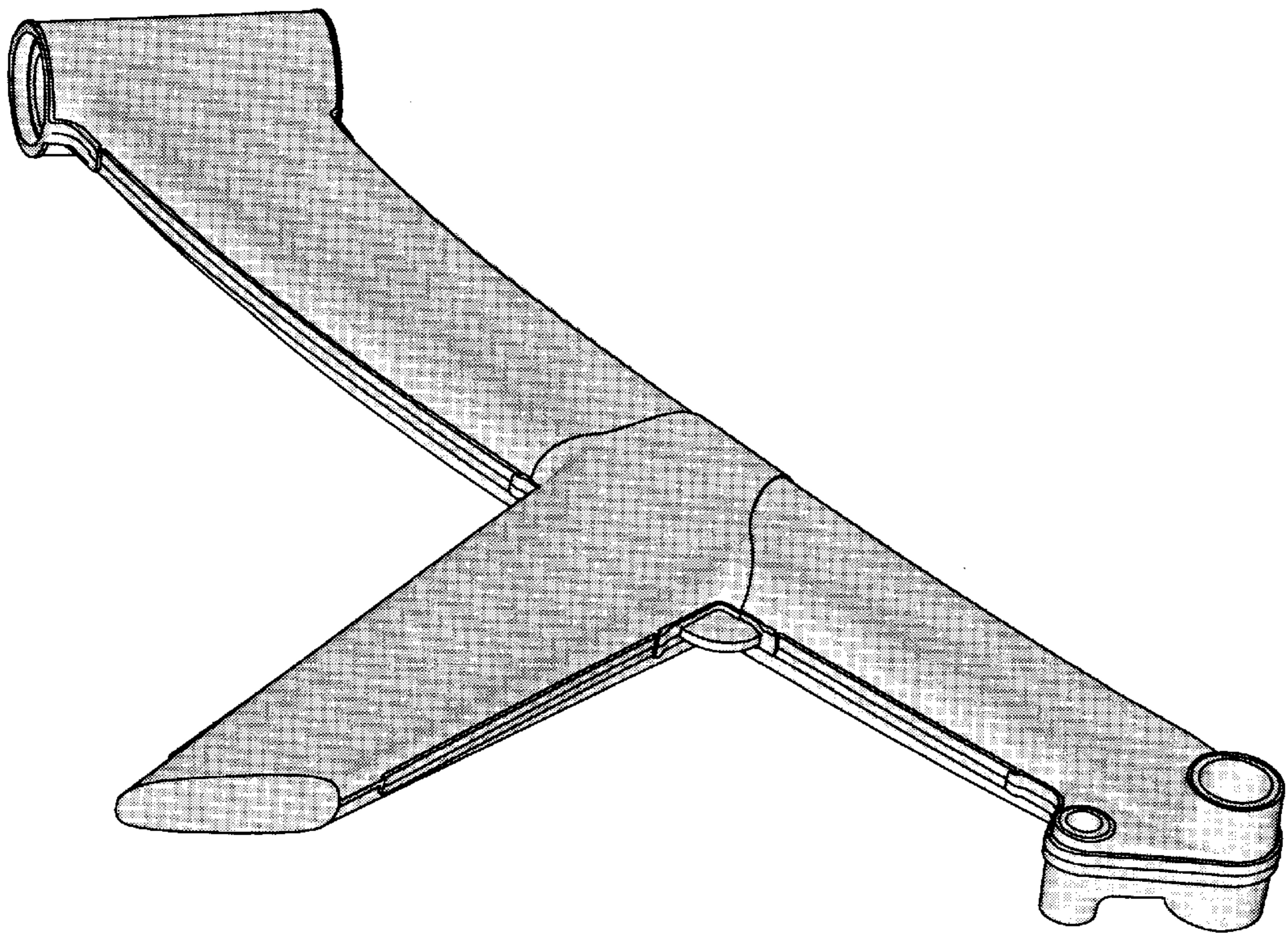

FIG. 8

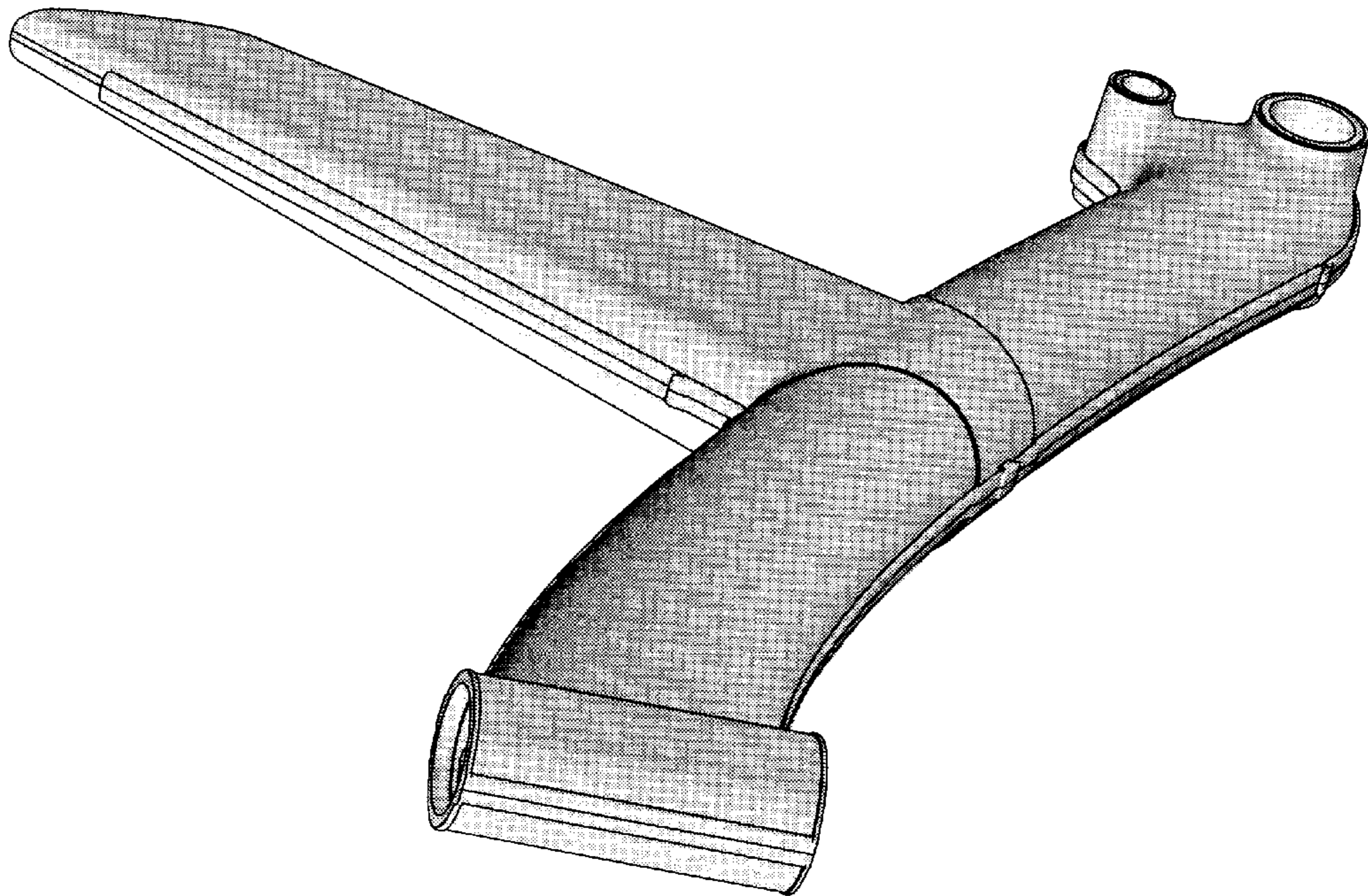



*FIG. 10*



*FIG. 11*



*FIG. 12*

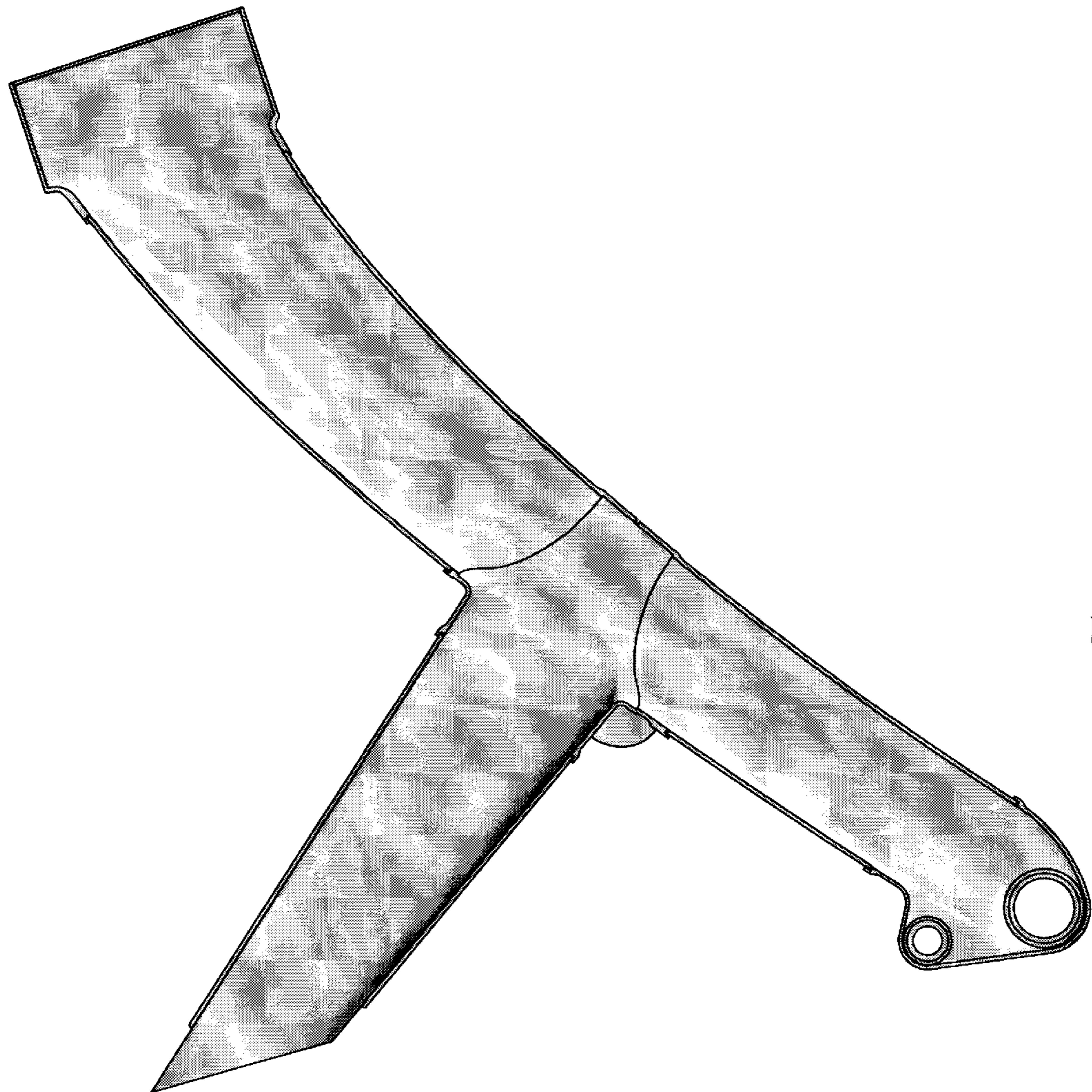

*FIG. 13*

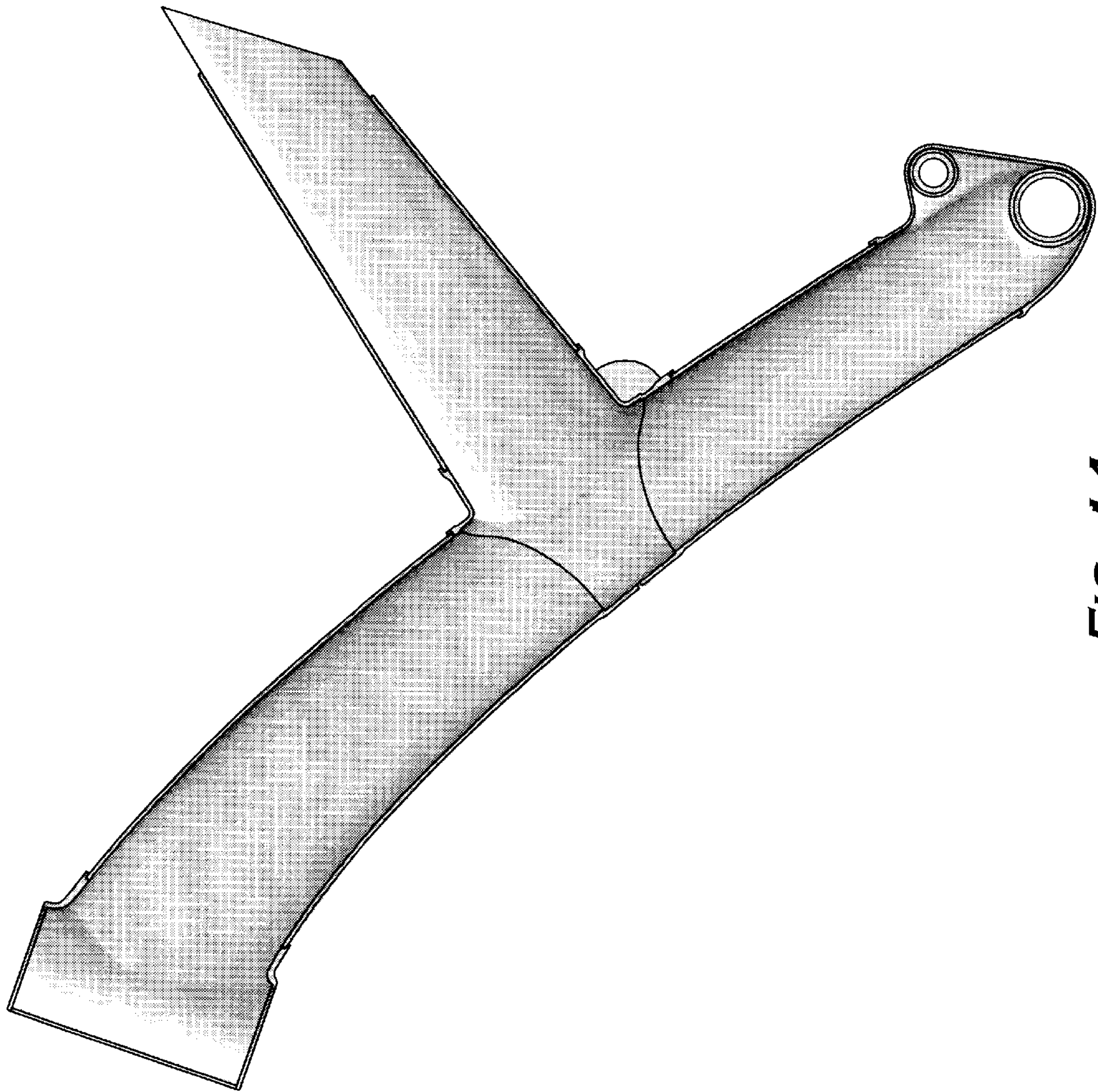

**FIG. 14**