



US00D412301S

United States Patent [19]

[11] Patent Number: **Des. 412,301**

Dirks

[45] Date of Patent: **** Jul. 27, 1999**

[54] SURFACE CONFIGURATION OF A VEHICLE

[75] Inventor: **Reinhard Dirks**, Stuttgart, Germany

[73] Assignee: **Daimler-Benz Aktiengesellschaft**,
Stuttgart, Germany

[**] Term: **14 Years**

[21] Appl. No.: **29/095,051**

[22] Filed: **Oct. 15, 1998**

[51] LOC (6) Cl. **12-08**

[52] U.S. Cl. **D12/96**

[58] Field of Search D12/96, 97; 296/190;
180/89.12-89.16

[56] References Cited

U.S. PATENT DOCUMENTS

D. 286,031	10/1986	Breitschwerdt et al.	D12/96
D. 302,257	7/1989	Breitschwerdt et al.	D12/96
D. 344,472	2/1994	Savio	D12/96
D. 367,443	2/1996	Sacco et al.	D12/96
4,143,732	3/1979	Schmude et al.	180/68.1

Primary Examiner—Melody N. Brown

[57] CLAIM

The ornamental design for a surface configuration of a vehicle, as shown and described.

DESCRIPTION

FIG. 1 is a front view of a surface configuration of a vehicle according to my novel design;

FIG. 2 is a left side view of a surface configuration of a vehicle according to my novel design;

FIG. 3 is a right side view of a surface configuration of a vehicle according to my novel design;

FIG. 4 is a perspective view from the front right of a surface configuration of a vehicle according to my novel design;

FIG. 5 is a perspective view from the rear left of a surface configuration of a vehicle according to my novel design;

FIG. 6 is a front view of a second embodiment of a surface configuration of a vehicle according to my novel design;

FIG. 7 is a left side view of a second embodiment of a surface configuration of a vehicle according to my novel design;

FIG. 8 is a right side view of a second embodiment of a surface configuration of a vehicle according to my novel design; and,

FIG. 9 is a perspective view from the front right of a second embodiment of a surface configuration of a vehicle according to my novel design.

The rear side of the surface configuration of a vehicle is plain and unornamented. The dash line included depicts environment and is not part of the claimed design.

1 Claim, 7 Drawing Sheets

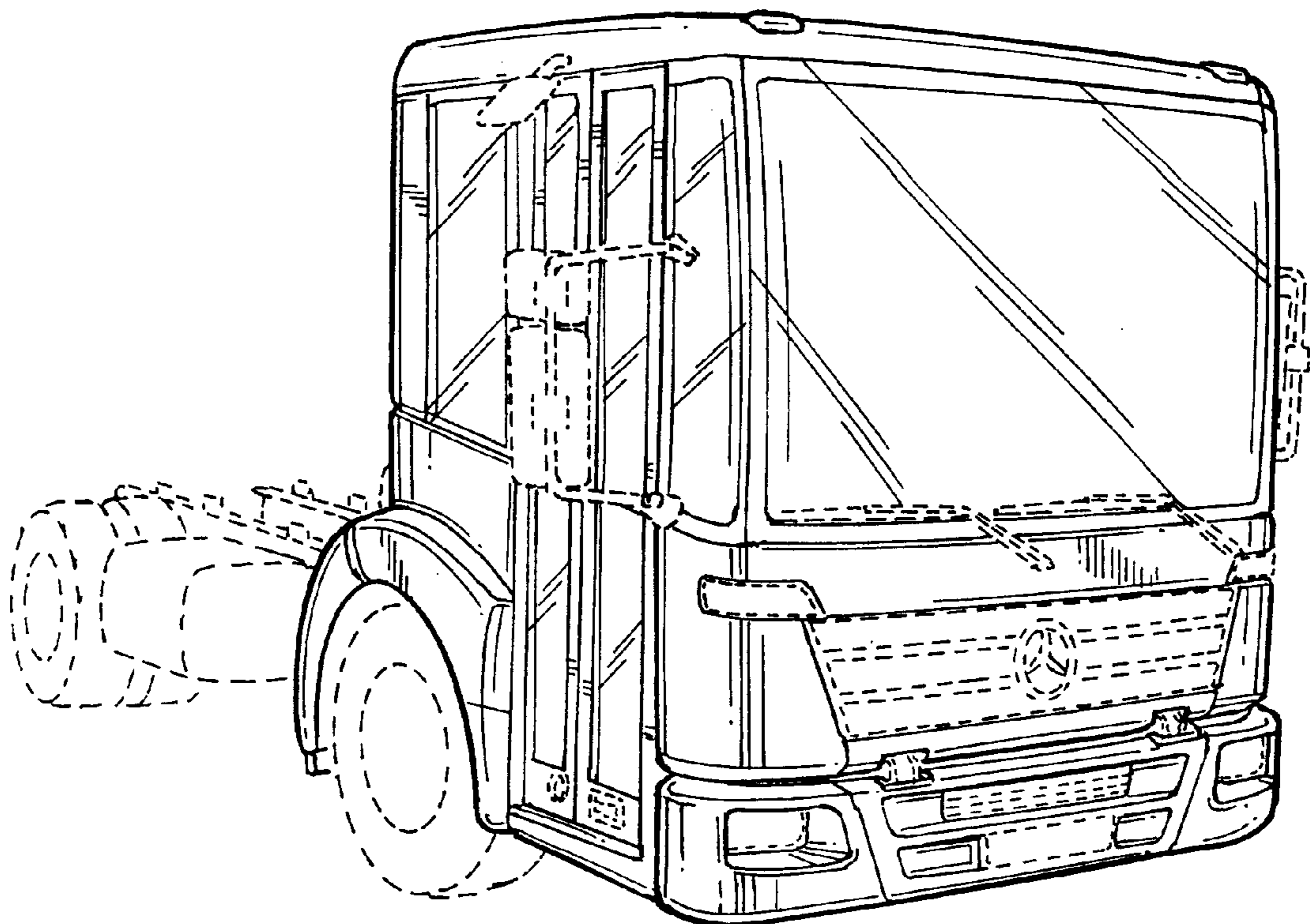

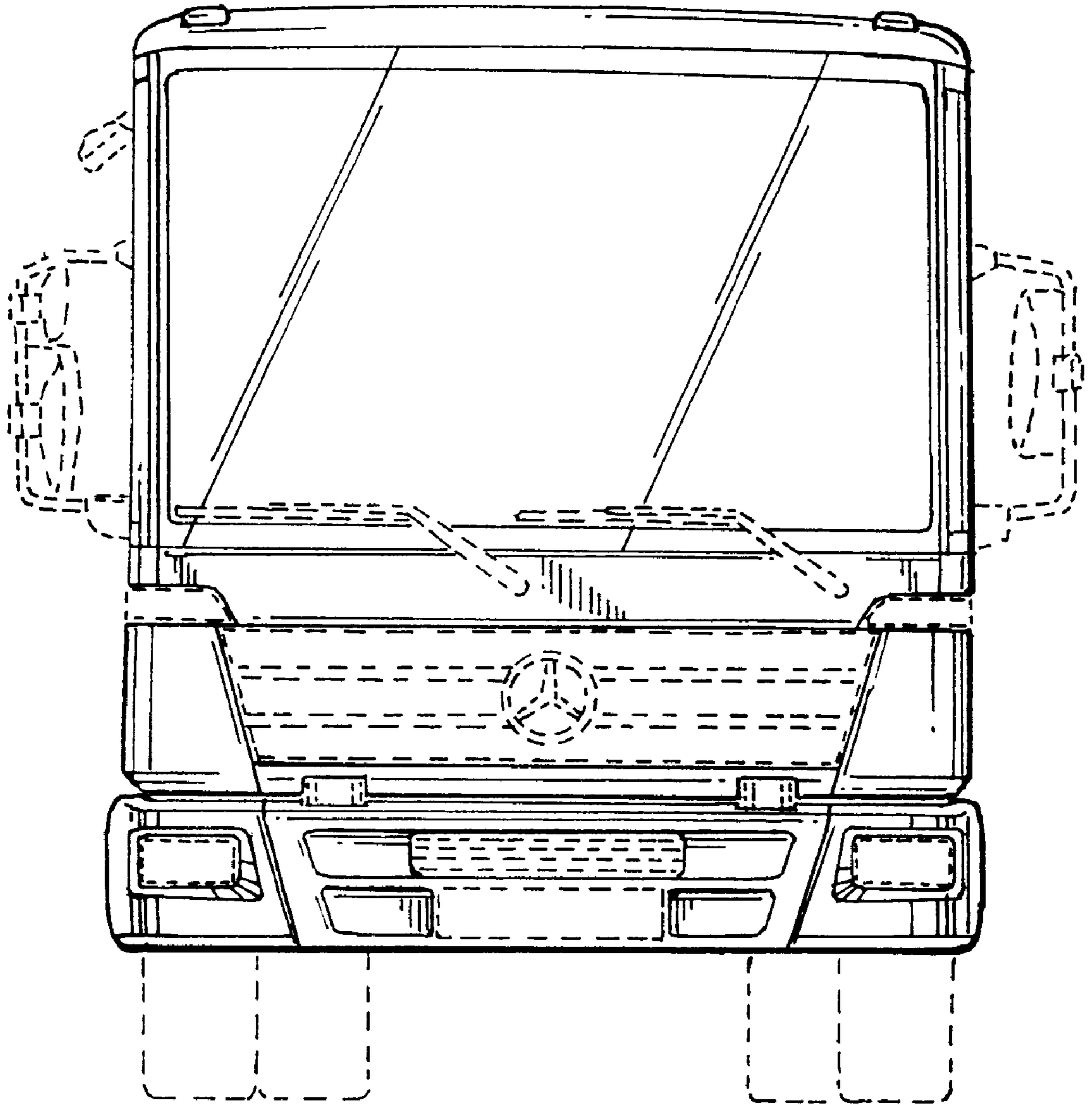

FIG. 1

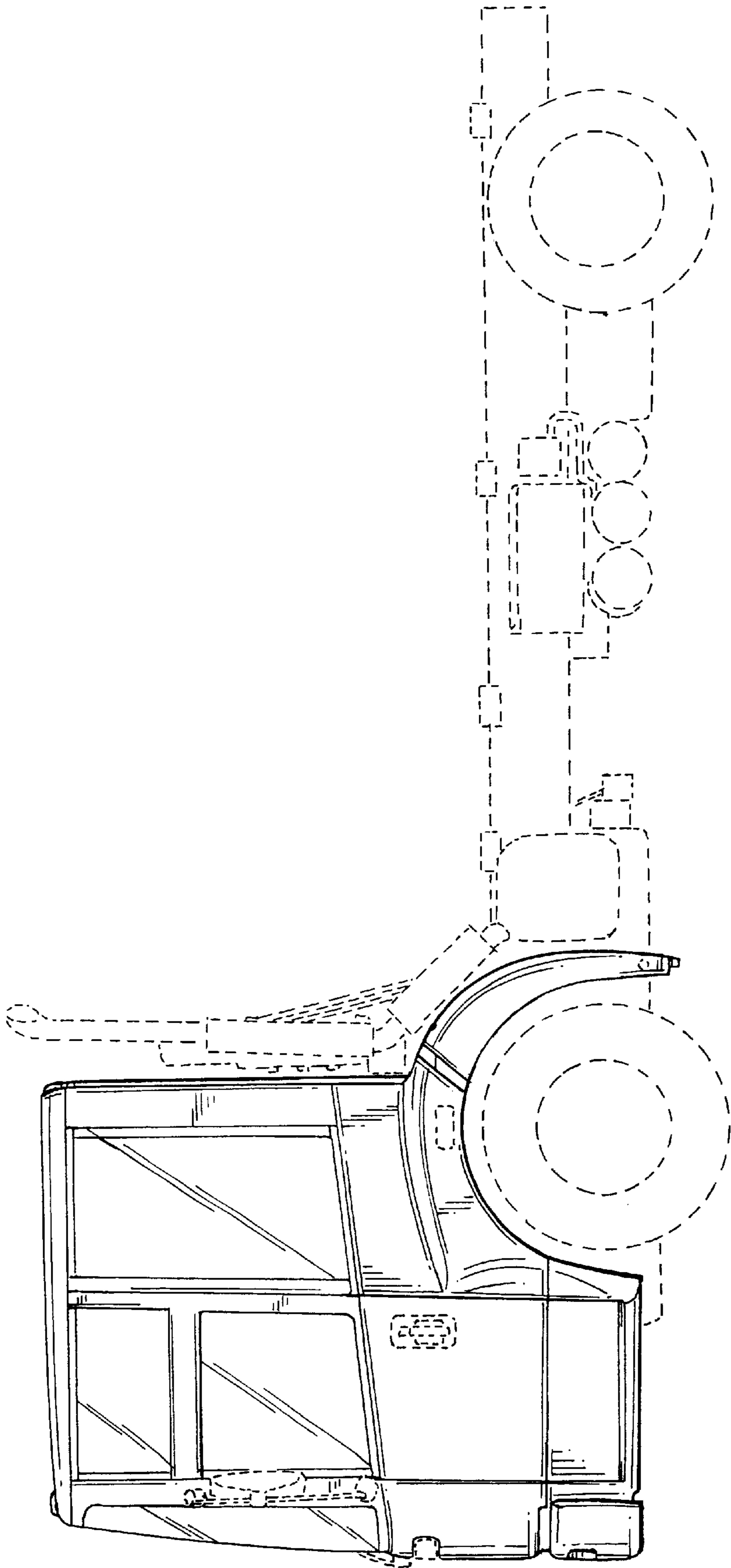

FIG. 2

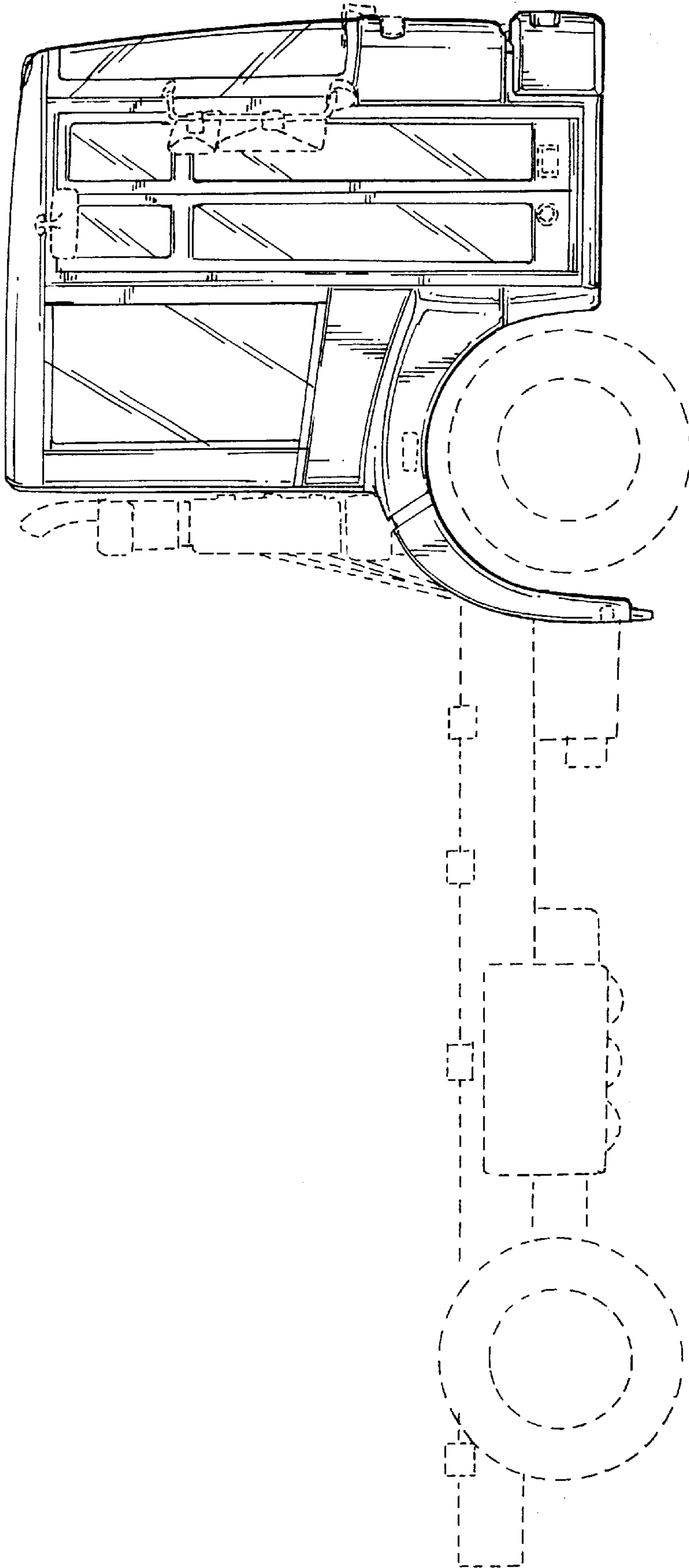

FIG. 3

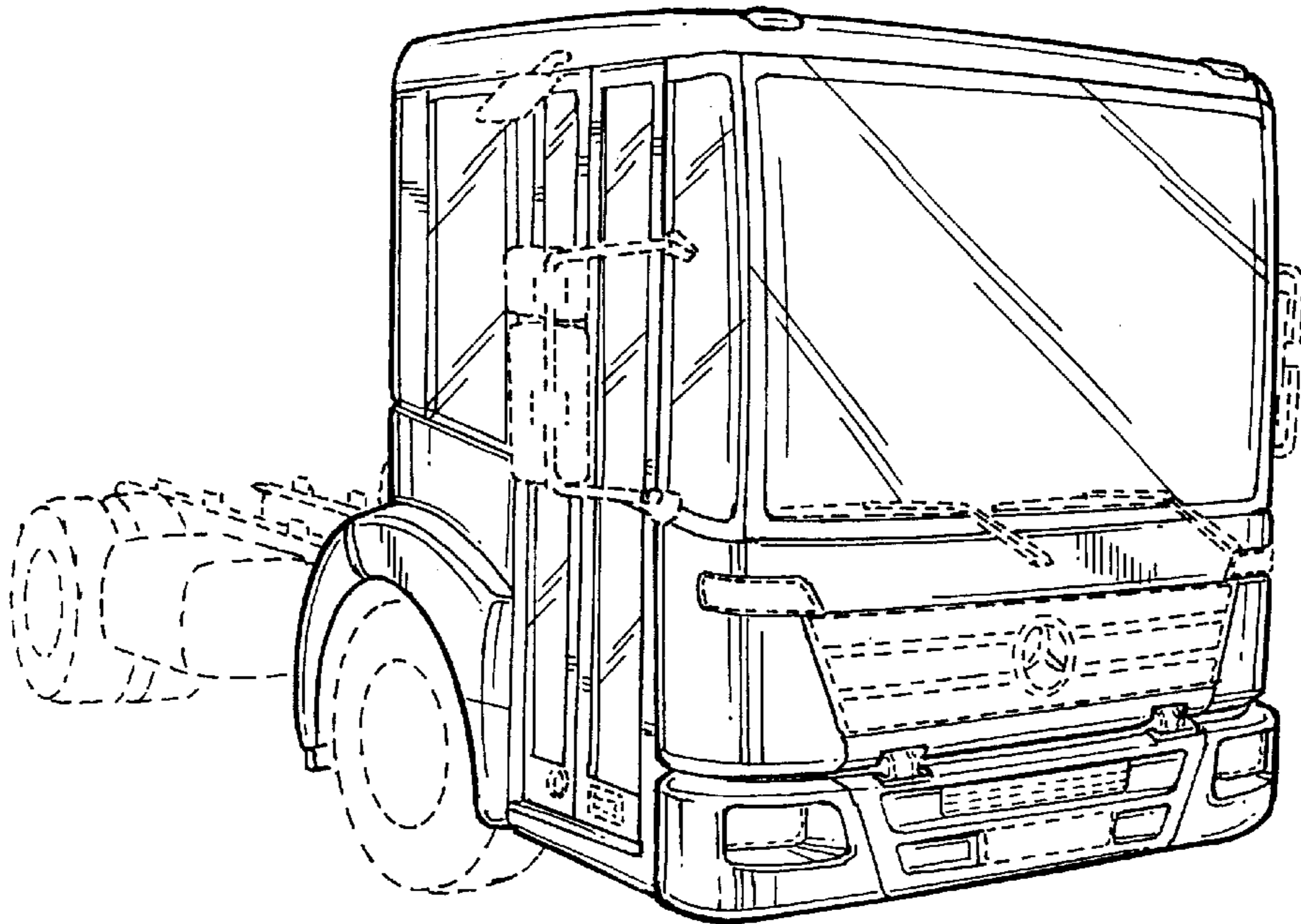

FIG. 4

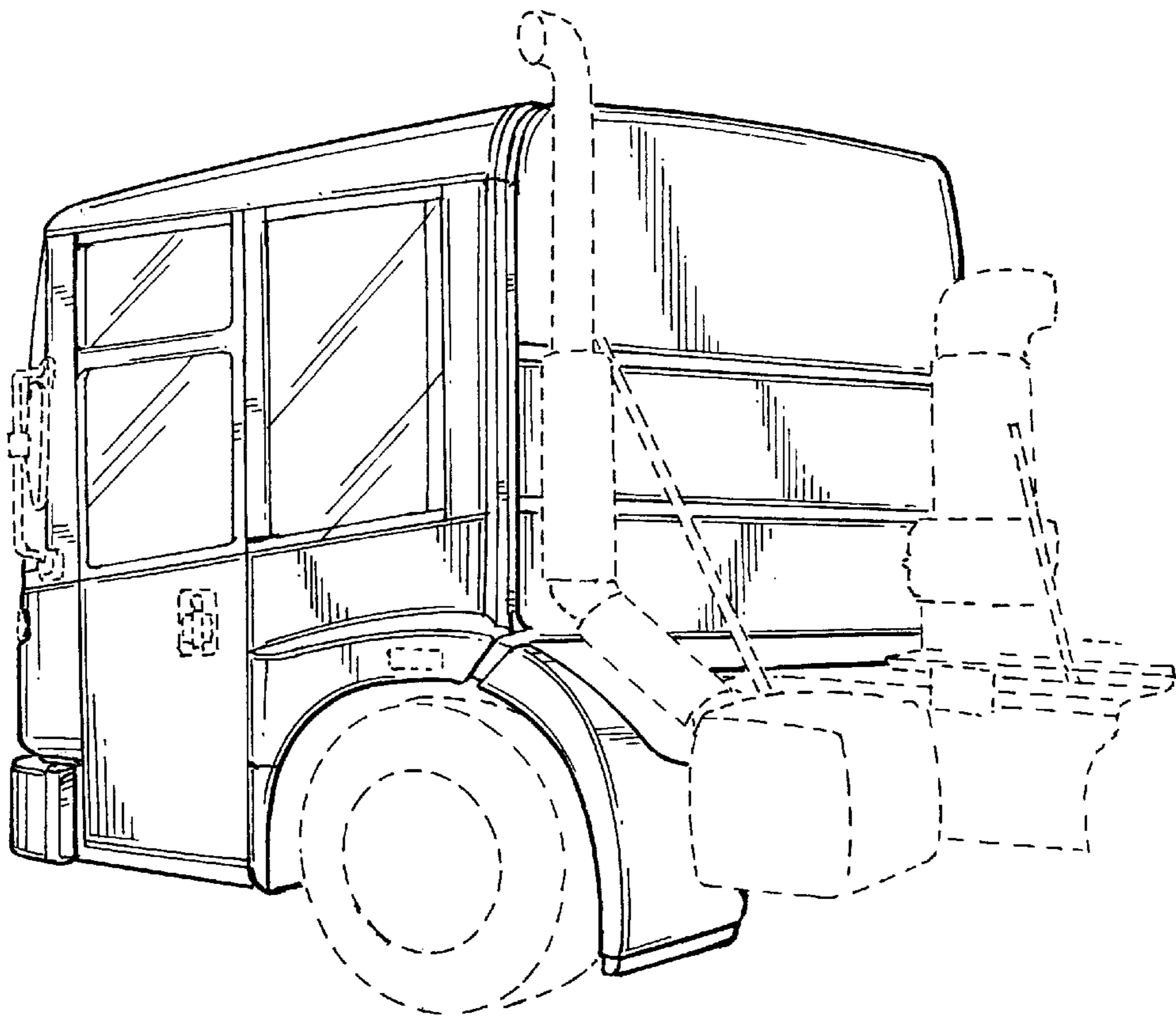

FIG. 5

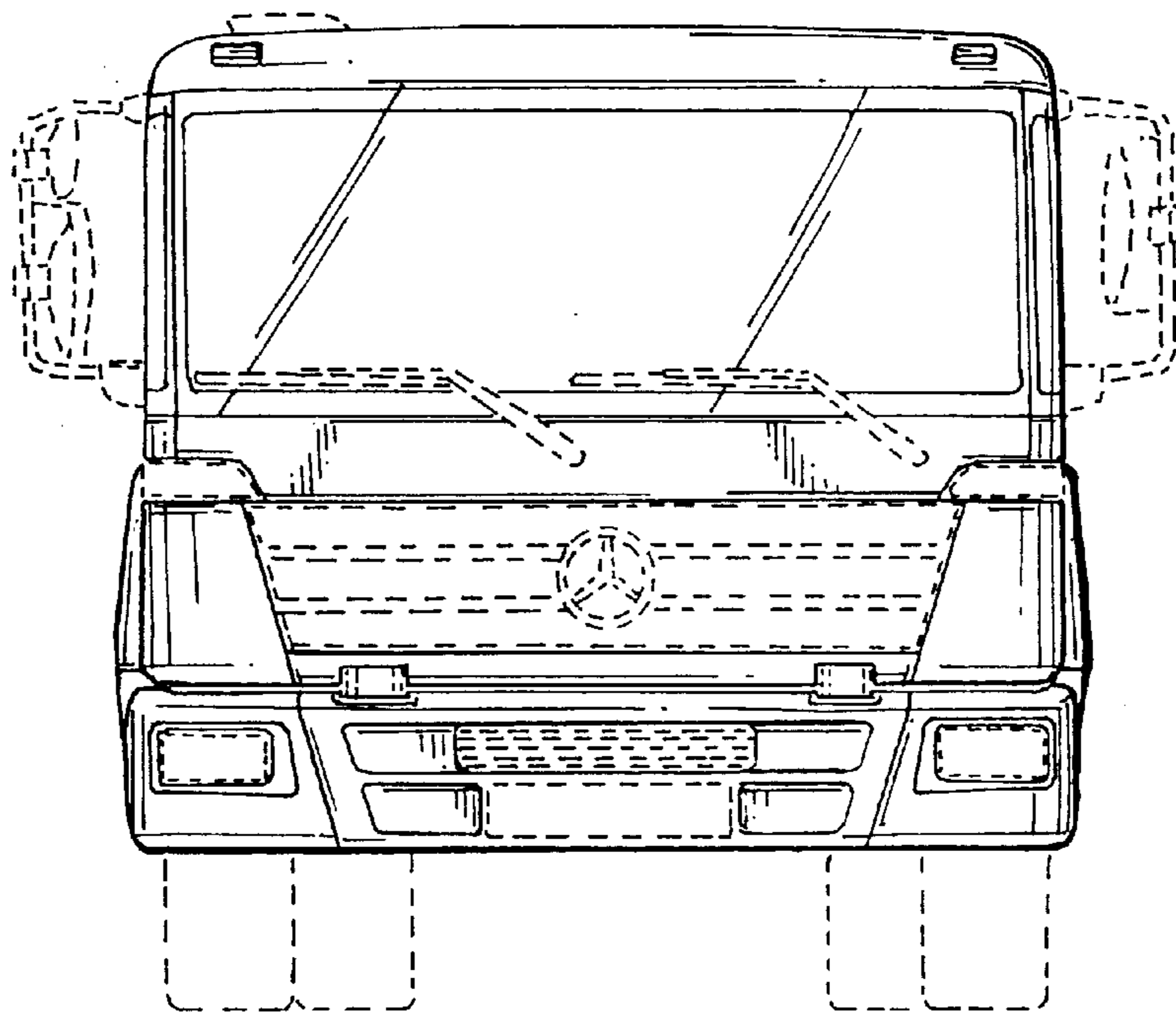

FIG. 6

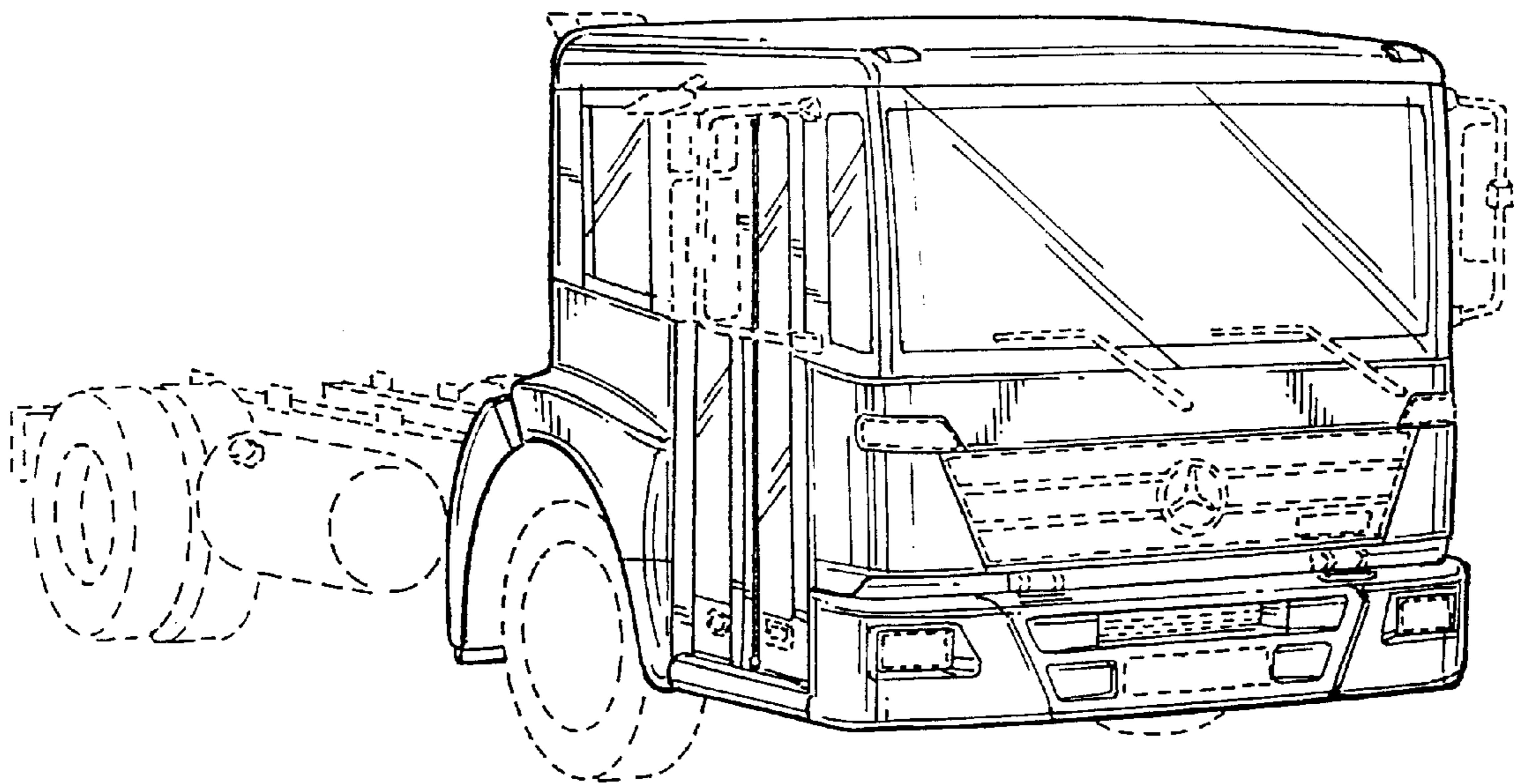

FIG. 9

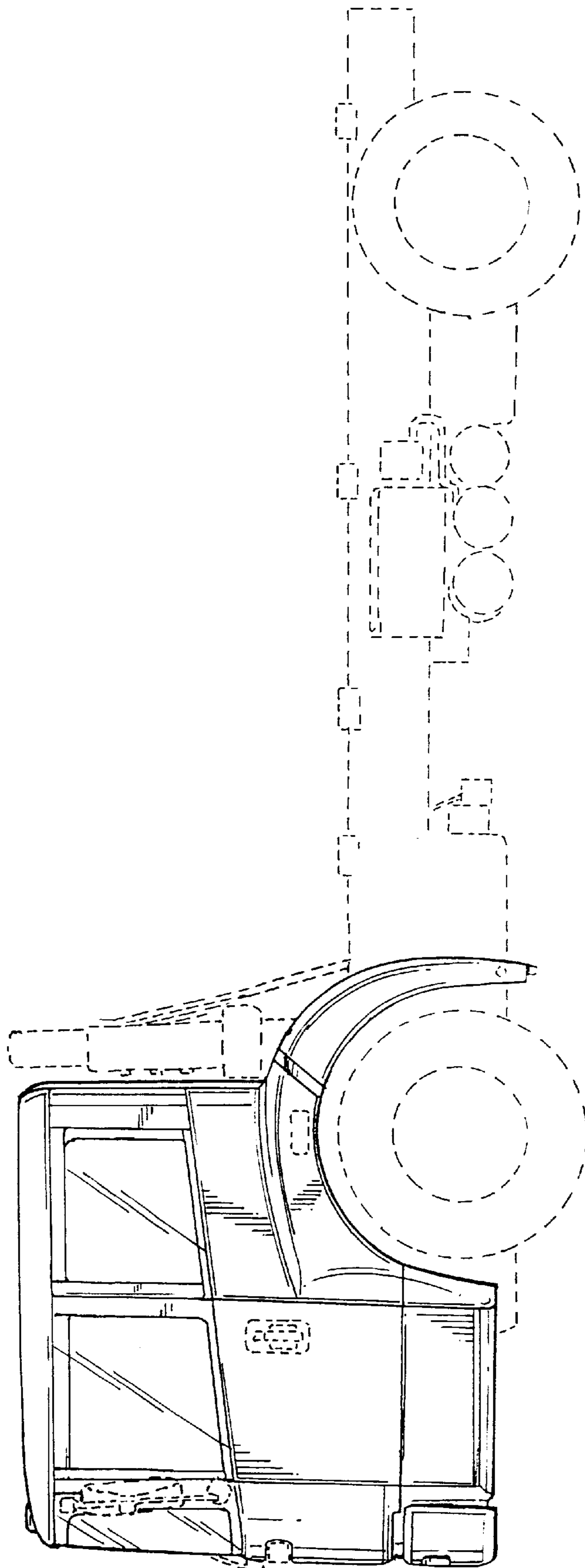

FIG. 7

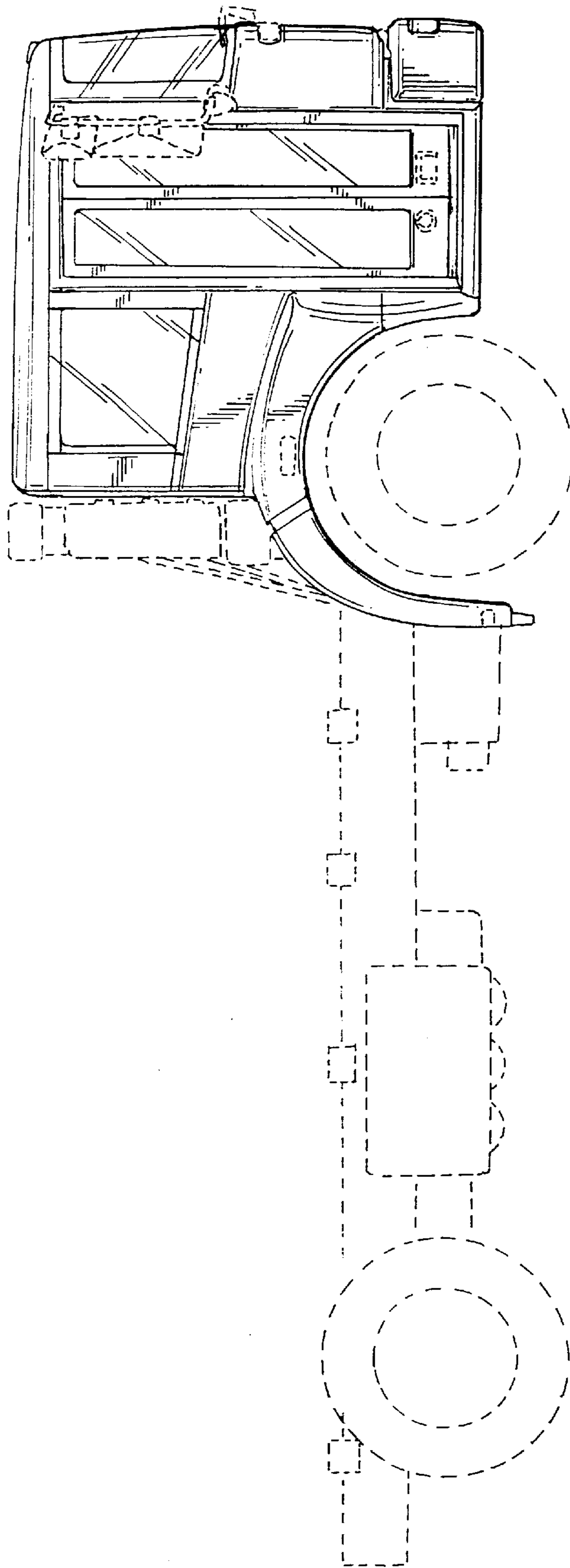

FIG. 8