



US00D411978S

United States Patent [19]
Elbertse

[11] **Patent Number: Des. 411,978**
[45] **Date of Patent: ** Jul. 13, 1999**

[54] **VEHICLE WHEEL FRONT FACE**

[75] **Inventor: John Elbertse, San Juan Capistrano, Calif.**

[73] **Assignee: American Eagle Wheel Corporation, Chino, Calif.**

[**] **Term: 14 Years**

[21] **Appl. No.: 29/082,161**

[22] **Filed: Jan. 16, 1998**

[51] **LOC (6) Cl. 12-16**

[52] **U.S. Cl. D12/211**

[58] **Field of Search D12/204-213;
301/64.1, 65, 37.1**

D. 237,703 11/1975 Clement et al. D12/211
D. 248,551 7/1978 Sekido et al. D12/211
D. 260,984 9/1981 Jonsson D12/209
D. 360,179 7/1995 Fuller D12/211
D. 363,910 11/1995 Chung D12/209
1,200,276 10/1916 Turner et al. D12/211 X

Primary Examiner—Jeffrey Asch
Assistant Examiner—Stacia Sinuik
Attorney, Agent, or Firm—Knobbe, Martens, Olson & Bear, LLP

[57] **CLAIM**

The ornamental design for a vehicle wheel front face, as shown and described.

DESCRIPTION

FIG. 1 is a front perspective view of the vehicle wheel front face of the present invention; and, FIG. 2 is an enlarged front elevational view thereof. The broken line showing of environment is for illustrative purposes only and forms no part of the claimed design.

[56] **References Cited**

U.S. PATENT DOCUMENTS

D. 74,024 12/1927 Putnam D12/211
D. 236,610 9/1975 Clement et al. D12/209

1 Claim, 2 Drawing Sheets

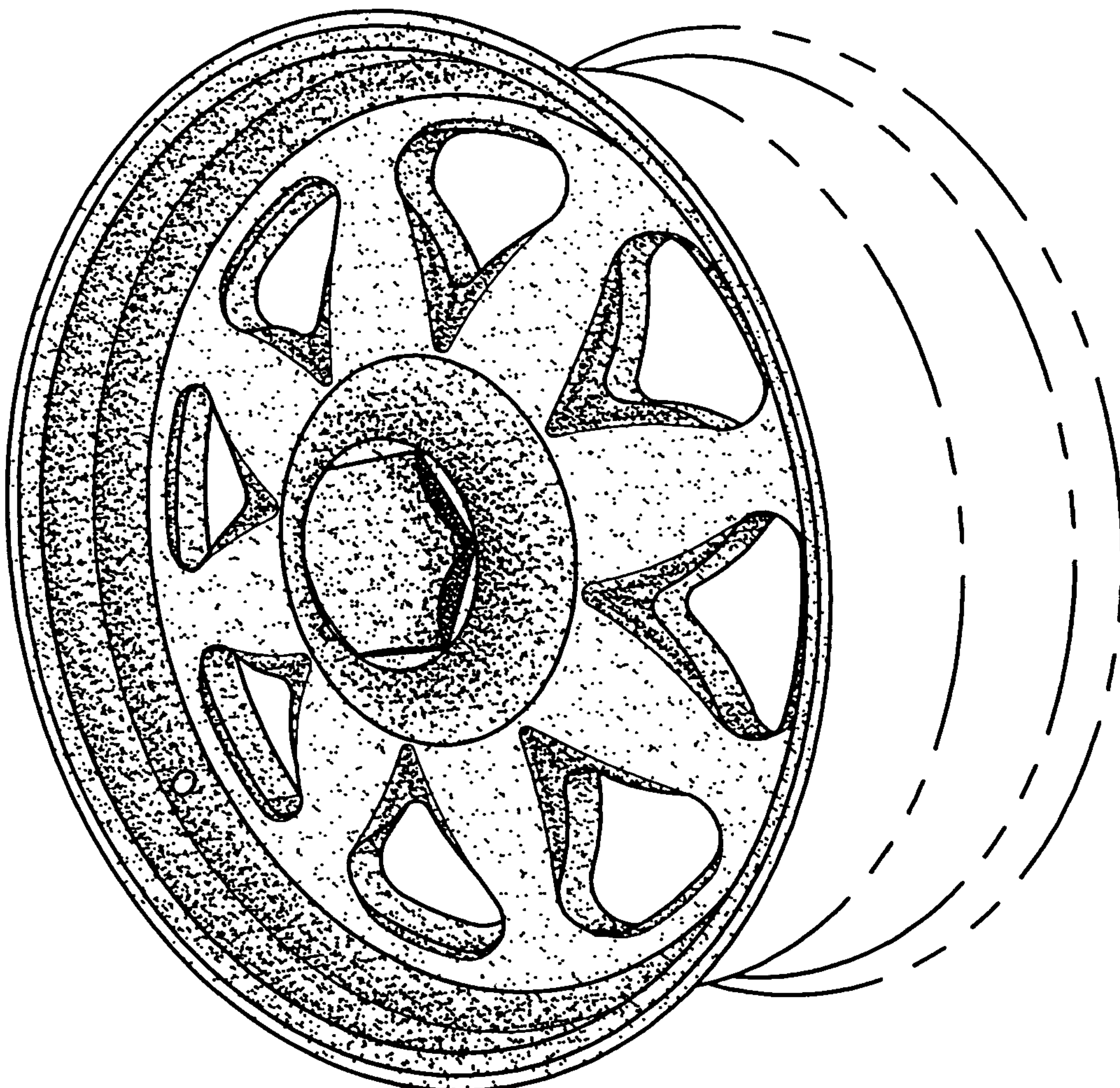

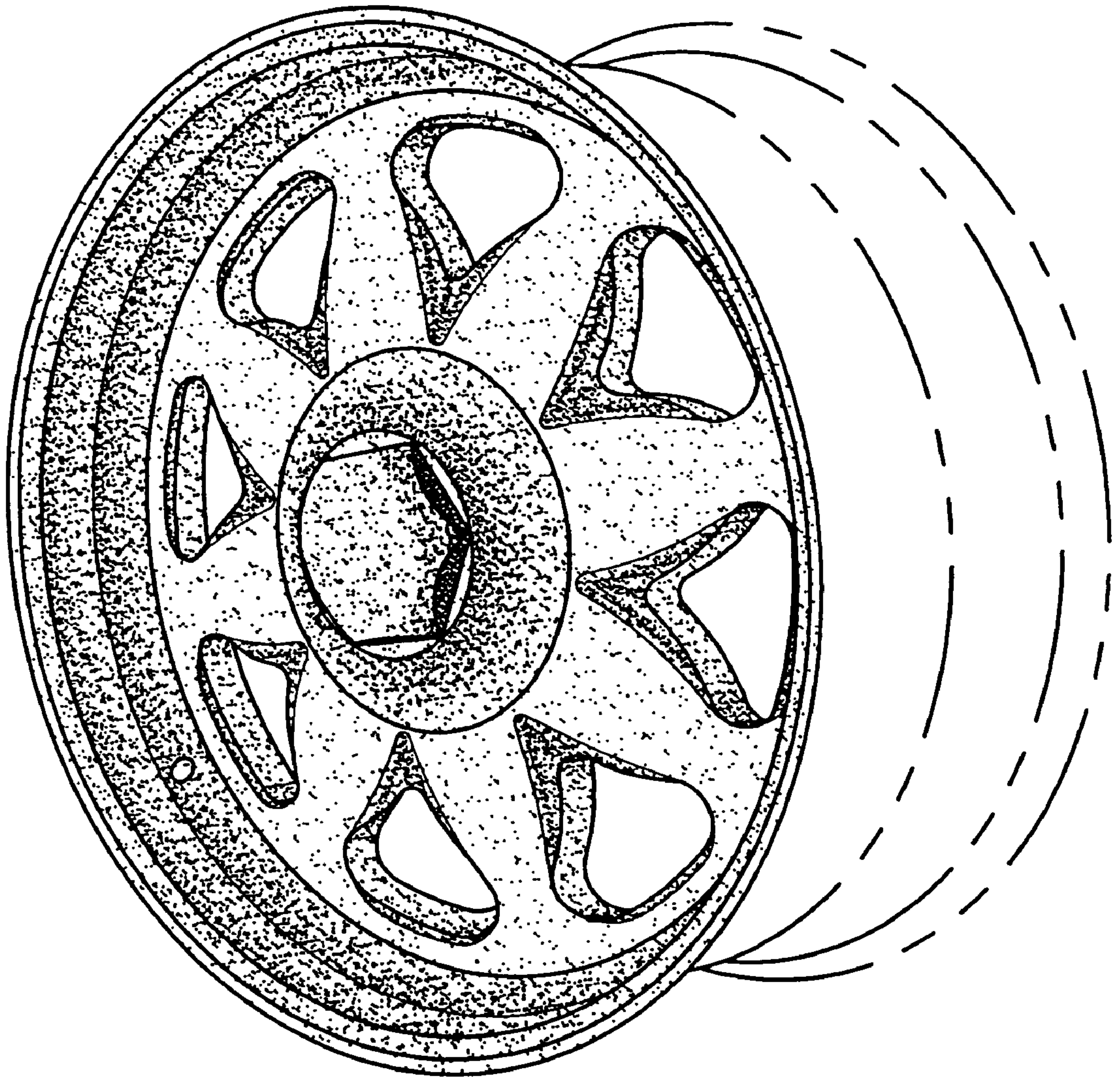

FIG. 1

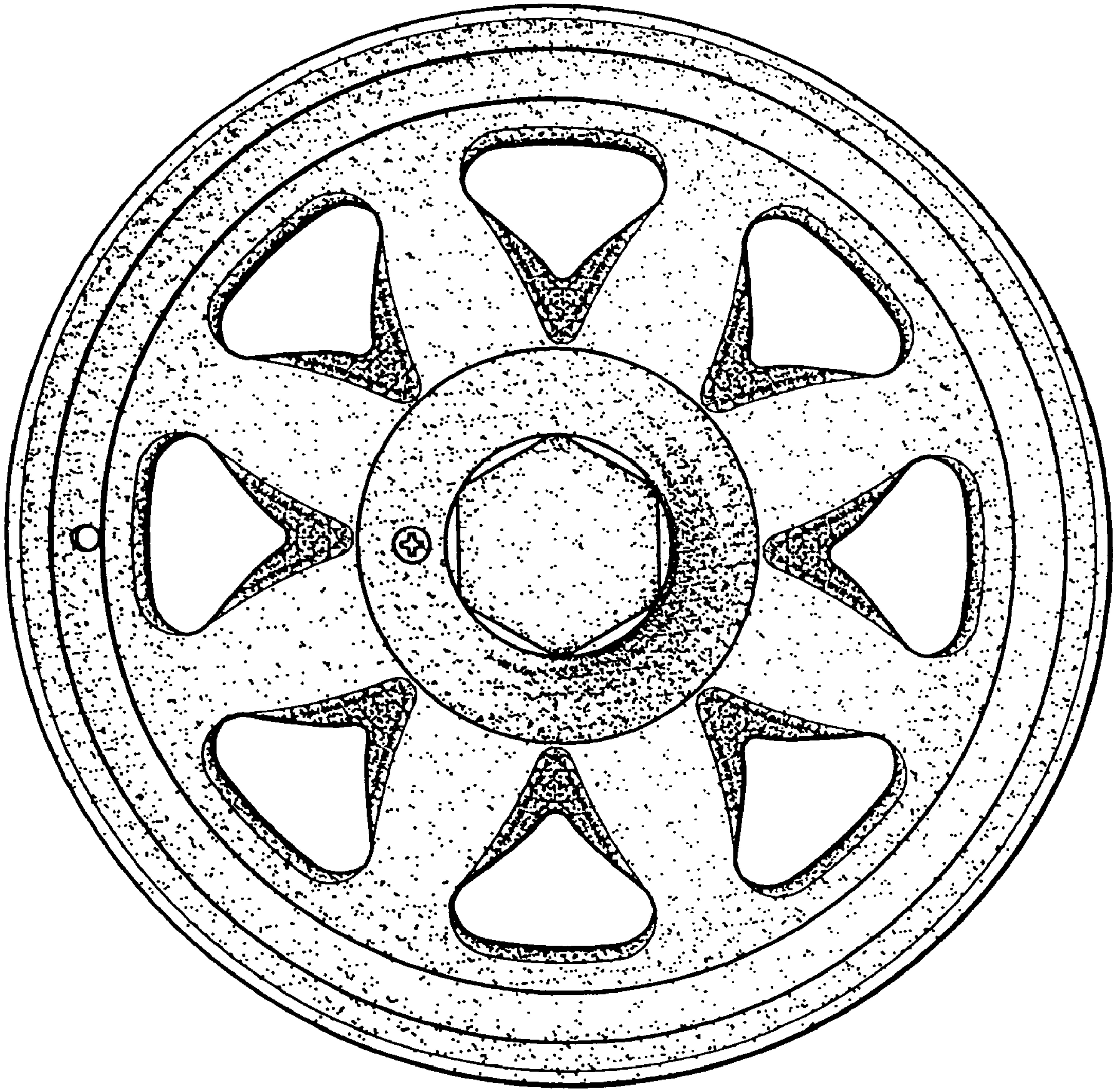

FIG. 2