



US00D411922S

United States Patent [19] Granados

[11] Patent Number: **Des. 411,922**

[45] Date of Patent: **** Jul. 13, 1999**

[54] PASSENGER SEAT

[75] Inventor: **Reginald Francis Granados**, Reading,
United Kingdom

[73] Assignee: **Britax Contour Limited**, Warwick,
United Kingdom

[**] Term: **14 Years**

[21] Appl. No.: **29/092,448**

[22] Filed: **Aug. 19, 1998**

Related U.S. Application Data

[30] Foreign Application Priority Data

Feb. 24, 1998 [GB] United Kingdom 2072731

[51] LOC (6) Cl. **06-01**

[52] U.S. Cl. **D6/356; D6/360**

[58] Field of Search D6/334, 335, 336,
D6/356, 360, 361, 367, 500, 501, 502;
297/423.28, 423.3

[56] References Cited

U.S. PATENT DOCUMENTS

D. 166,938	6/1952	Weltz	D6/356
D. 186,105	9/1959	Dietz	D6/356
D. 198,783	8/1964	Barecki	D6/356
D. 231,164	4/1974	Kellum	D6/367
D. 250,071	10/1978	Dickerson	D6/356
D. 273,157	3/1984	Staub	D6/356

D. 278,668	5/1985	Simpkins	D6/367
D. 281,471	11/1985	Sauter	D6/356
D. 364,508	11/1995	Pryor et al.	D6/356
D. 402,125	12/1998	Dryburgh et al.	D6/356
D. 405,275	2/1999	Dryburgh et al.	D6/356
4,113,311	9/1978	Reida	D6/361
5,507,562	4/1996	Wieland	297/423.3

Primary Examiner—Doris V. Coles
Assistant Examiner—Mimosa De
Attorney, Agent, or Firm—Davis and Bujold

[57] CLAIM

The ornamental design for a passenger seat, as shown and described.

DESCRIPTION

FIG. 1 is a perspective view from above and one side with the seat upright;
FIG. 2 is a front elevational view thereof;
FIG. 3 is a rear elevational view thereof;
FIG. 4 is a left side elevational view thereof, the right side elevational view being a mirror image;
FIG. 5 is a bottom plan view thereof;
FIG. 6 is a top plan view thereof;
FIG. 7 is a front perspective view from above and one side with the seat reclined;
FIG. 8 is a front perspective view from above and one side with the seat reclined and the head rest raised; and,
FIG. 9 is a front perspective view from above and one side with the seat reclined and the head rest tilted.

1 Claim, 3 Drawing Sheets

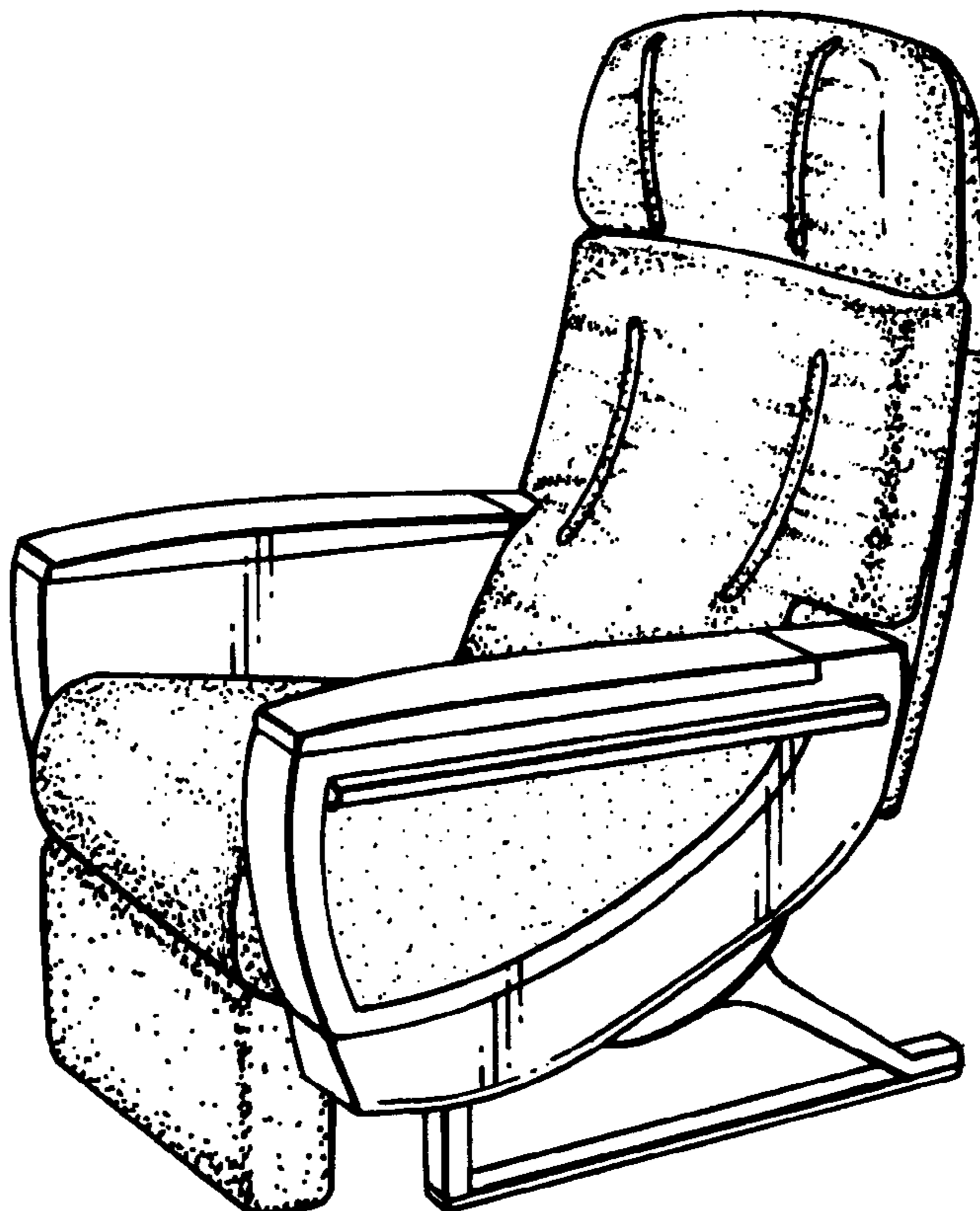

Fig.1.

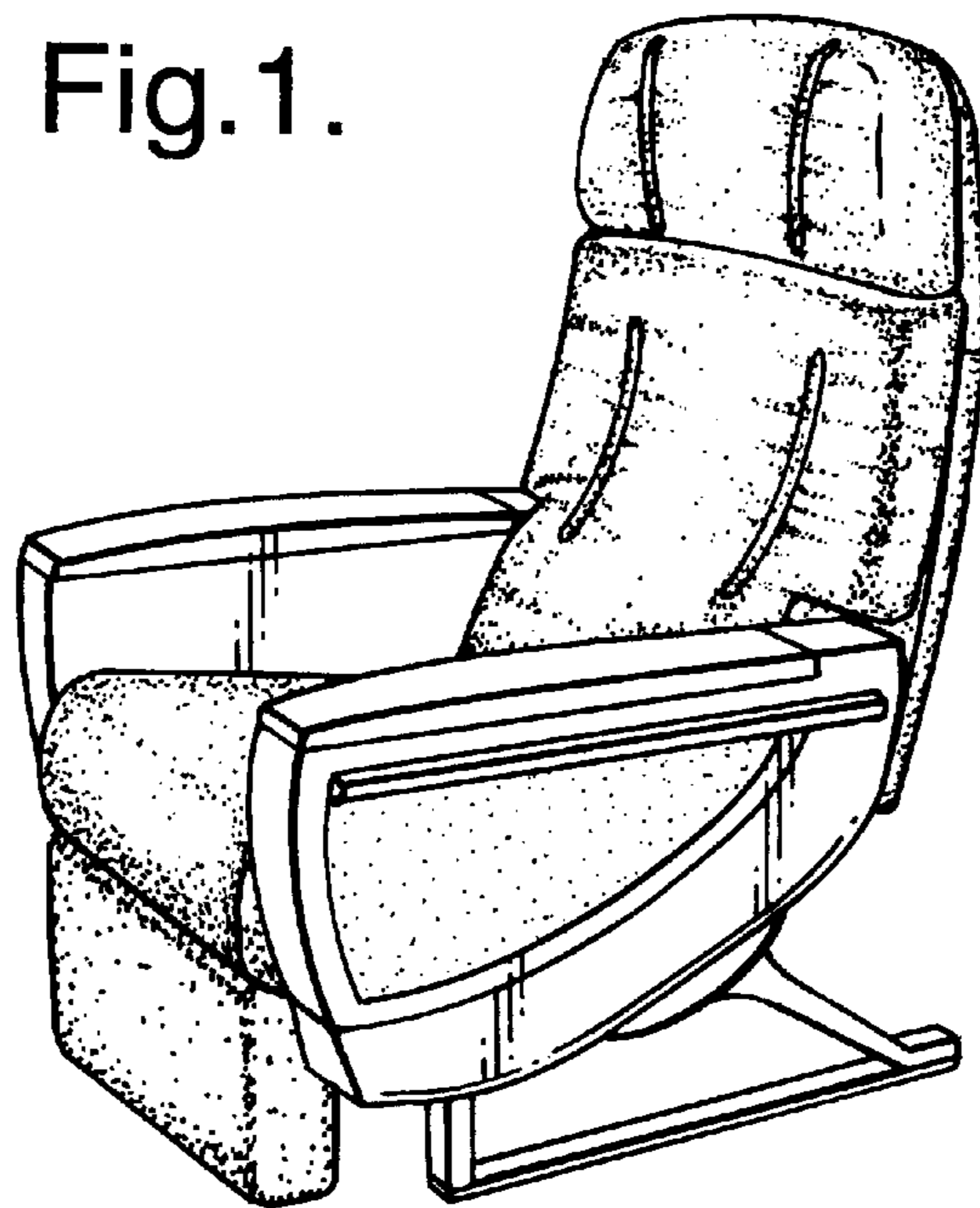

Fig.2.

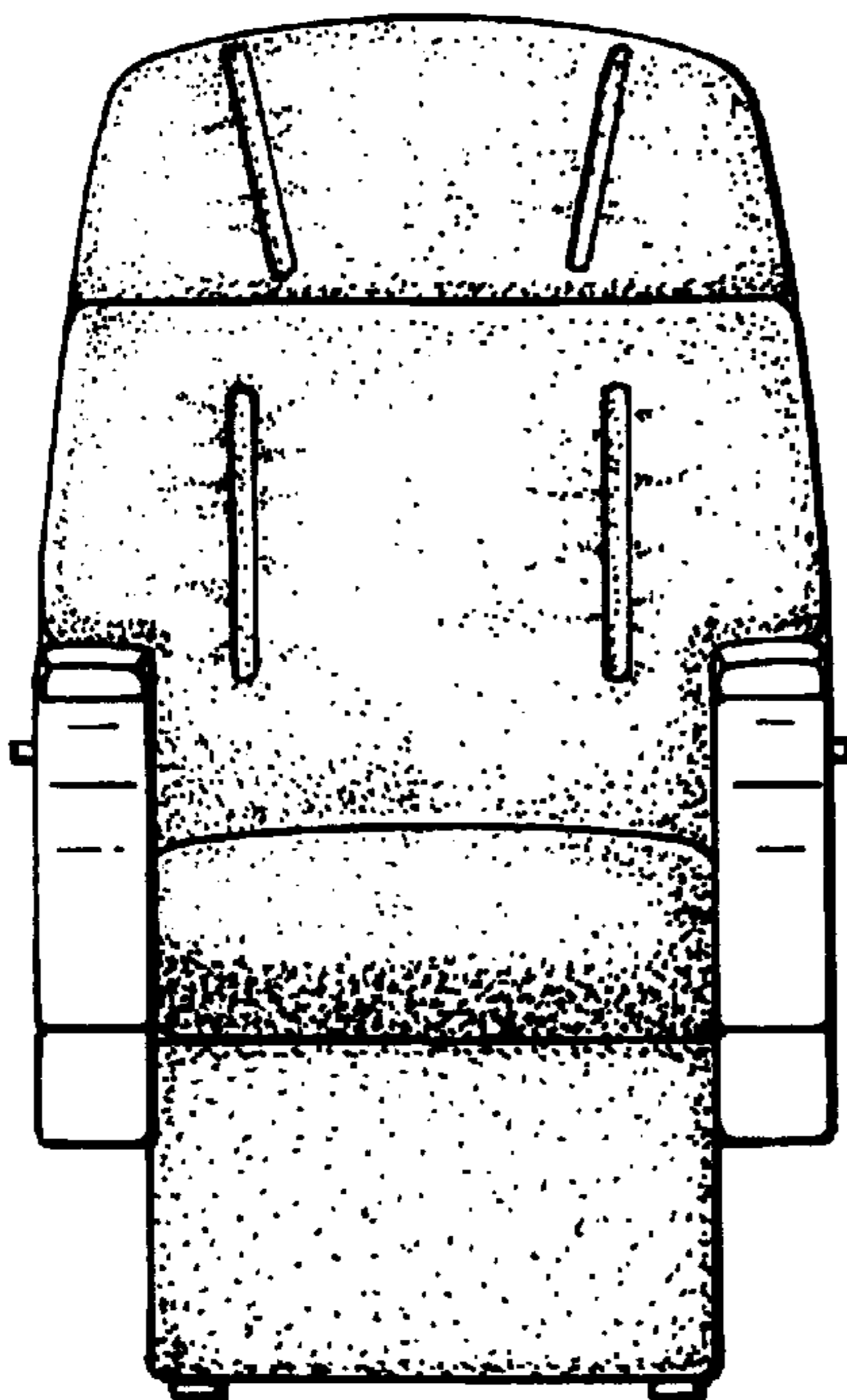
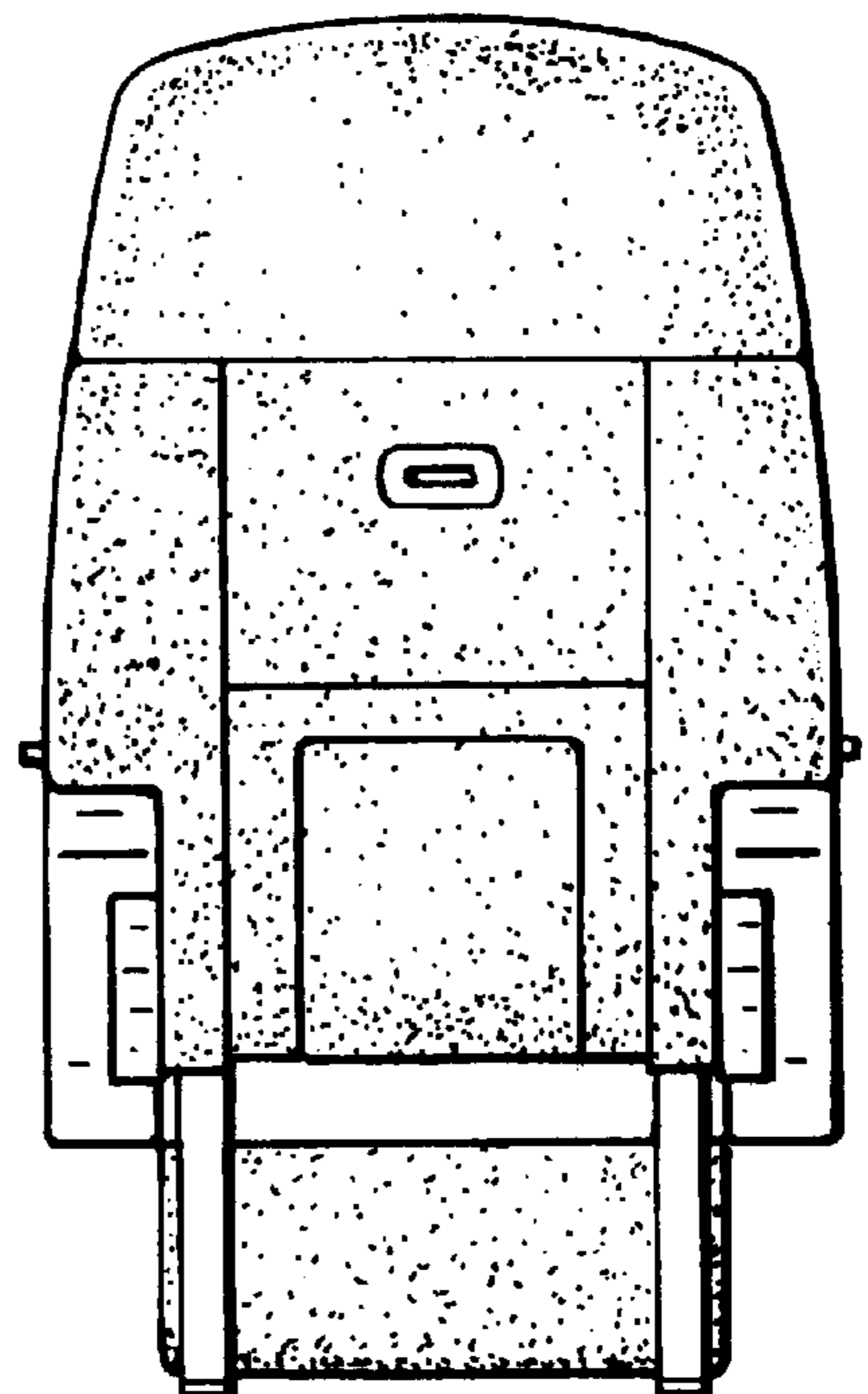

Fig.3.



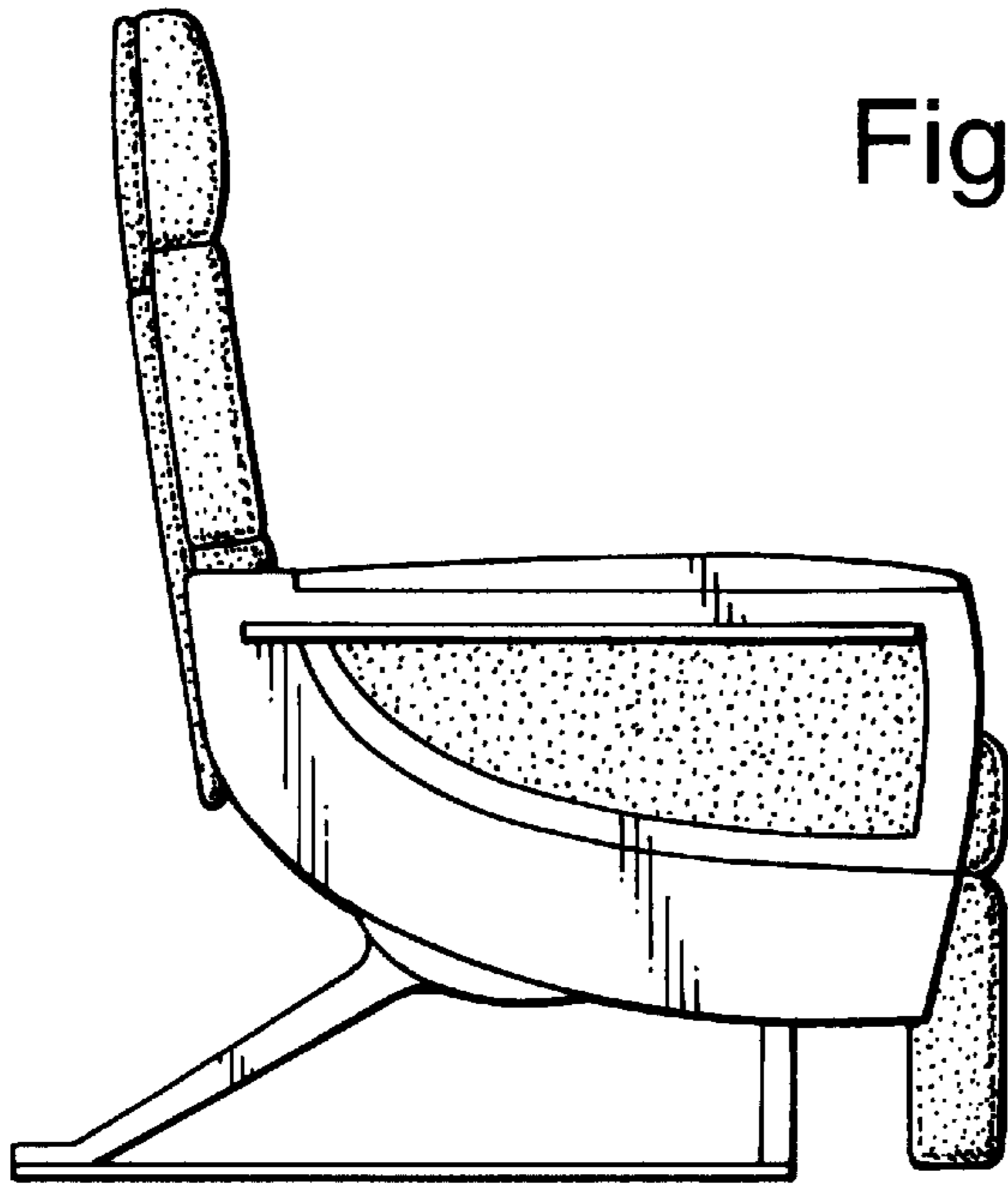

Fig.4.

Fig.6.

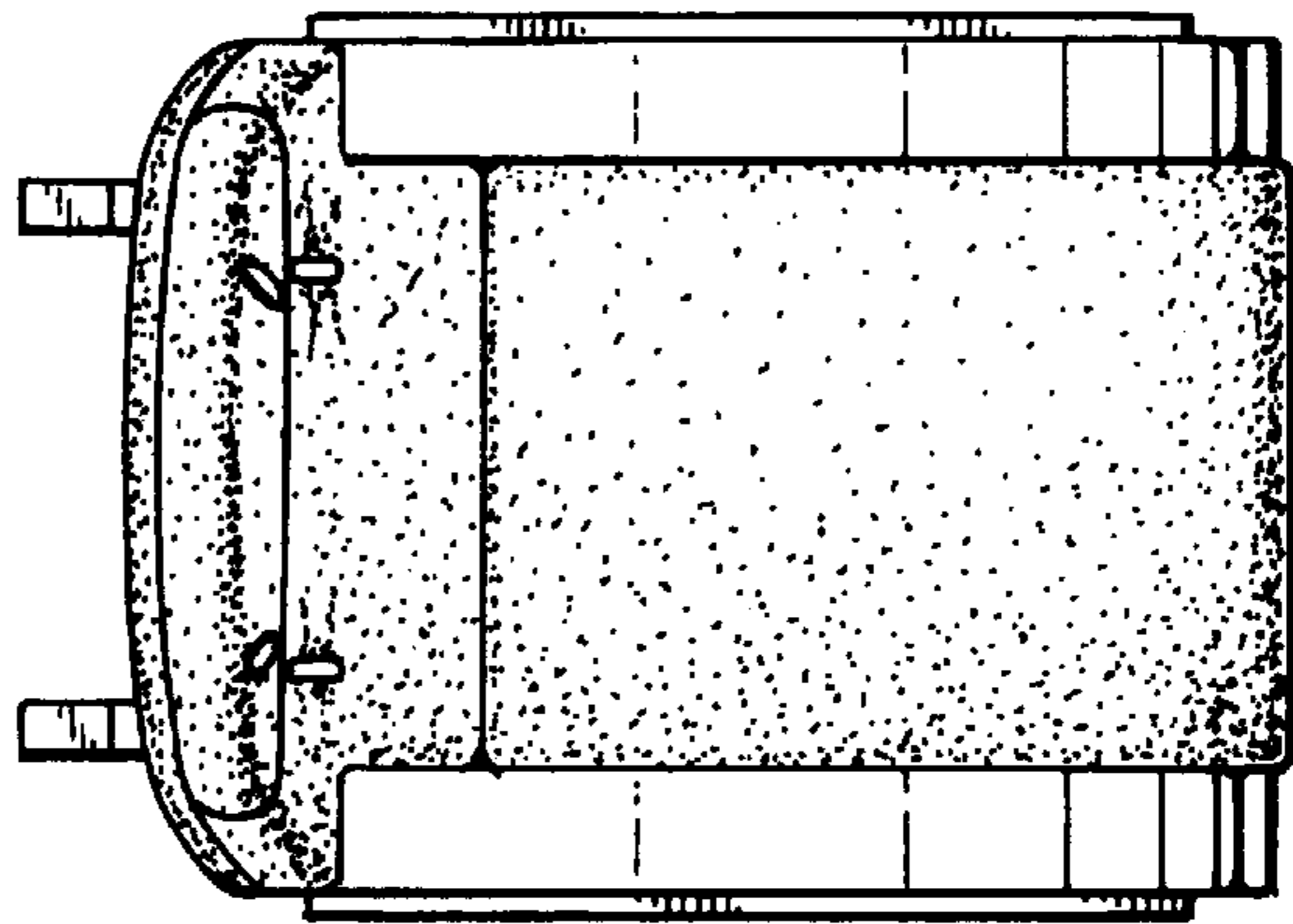

Fig.5.

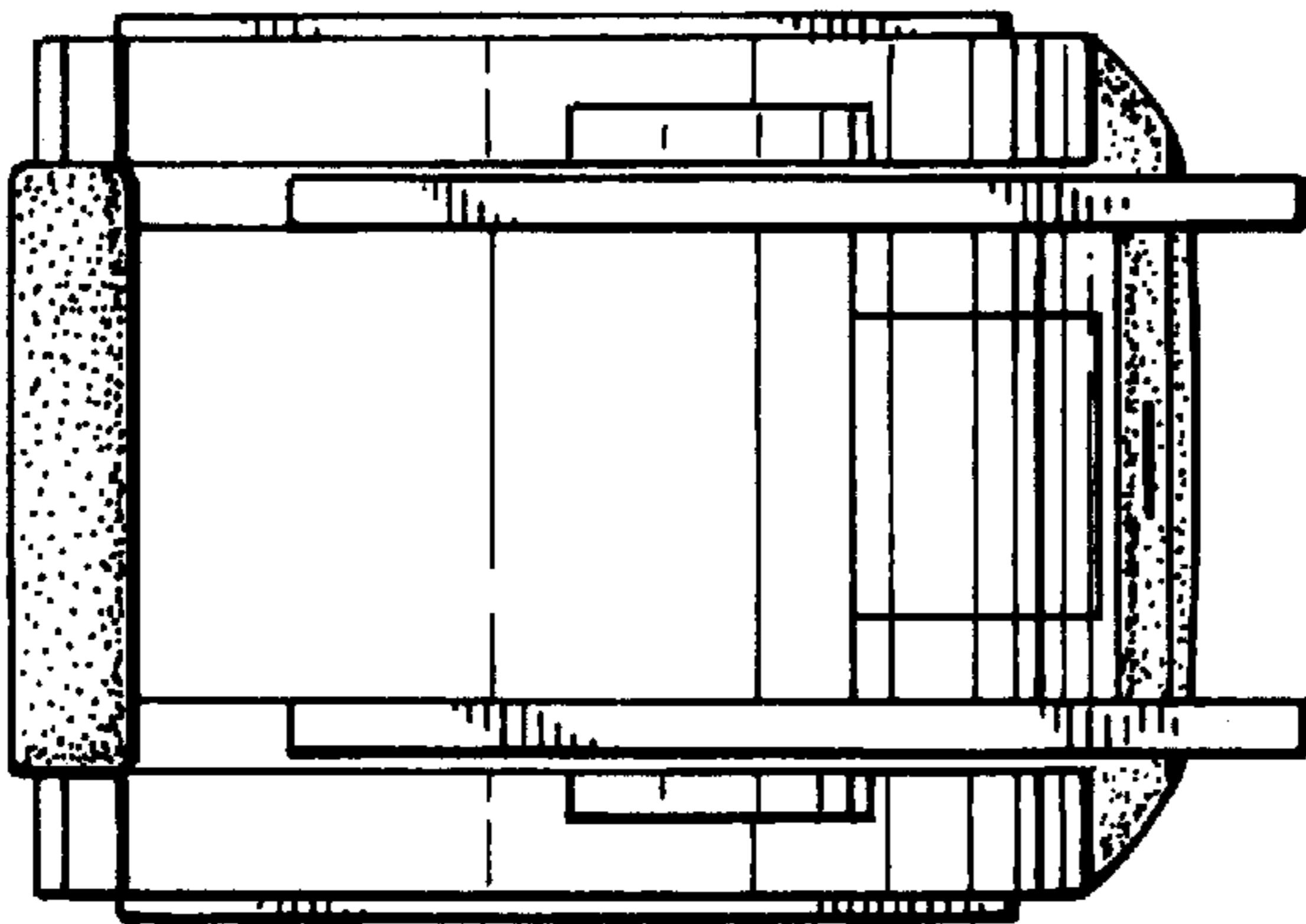

Fig.7.

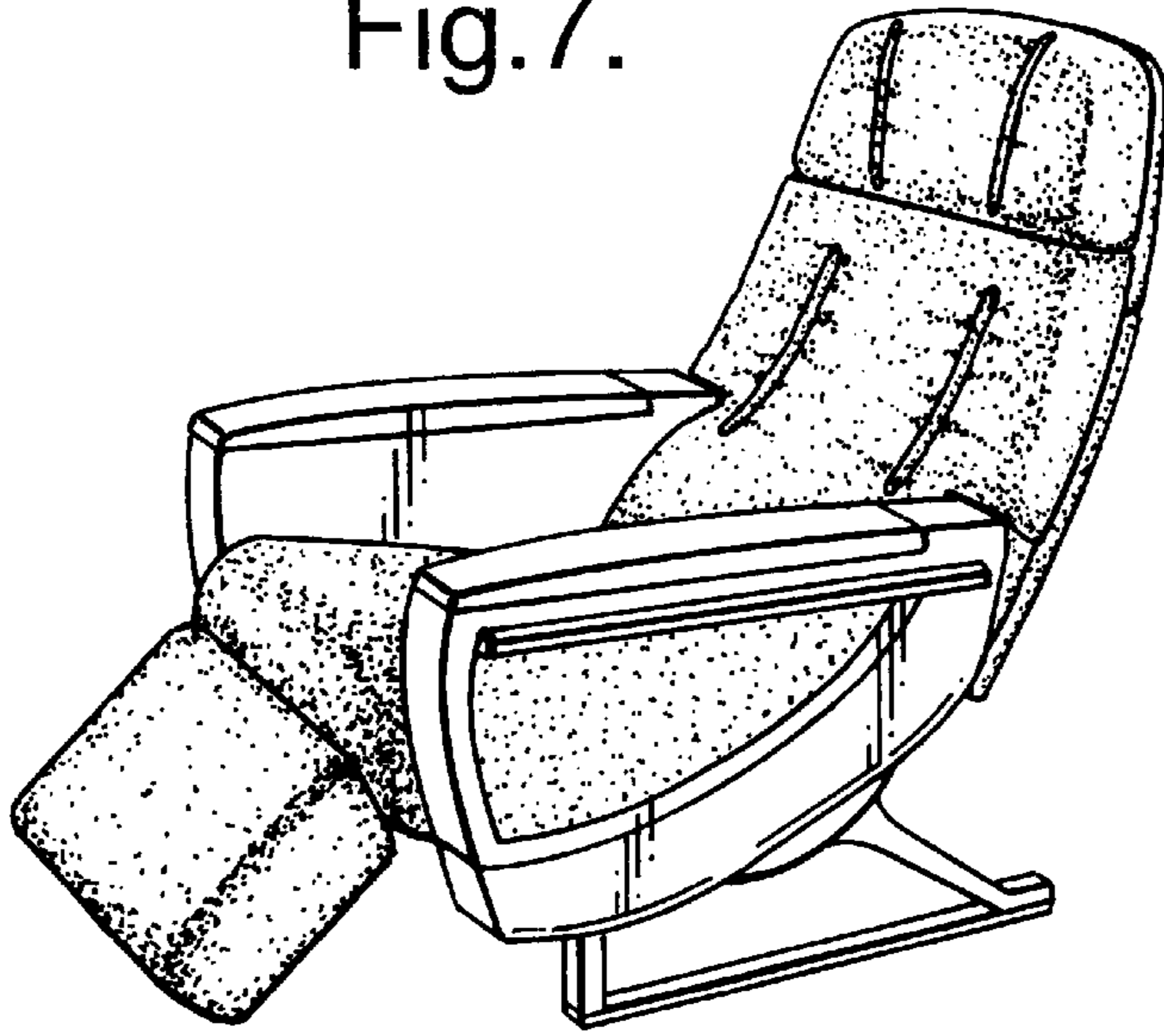

Fig.8.

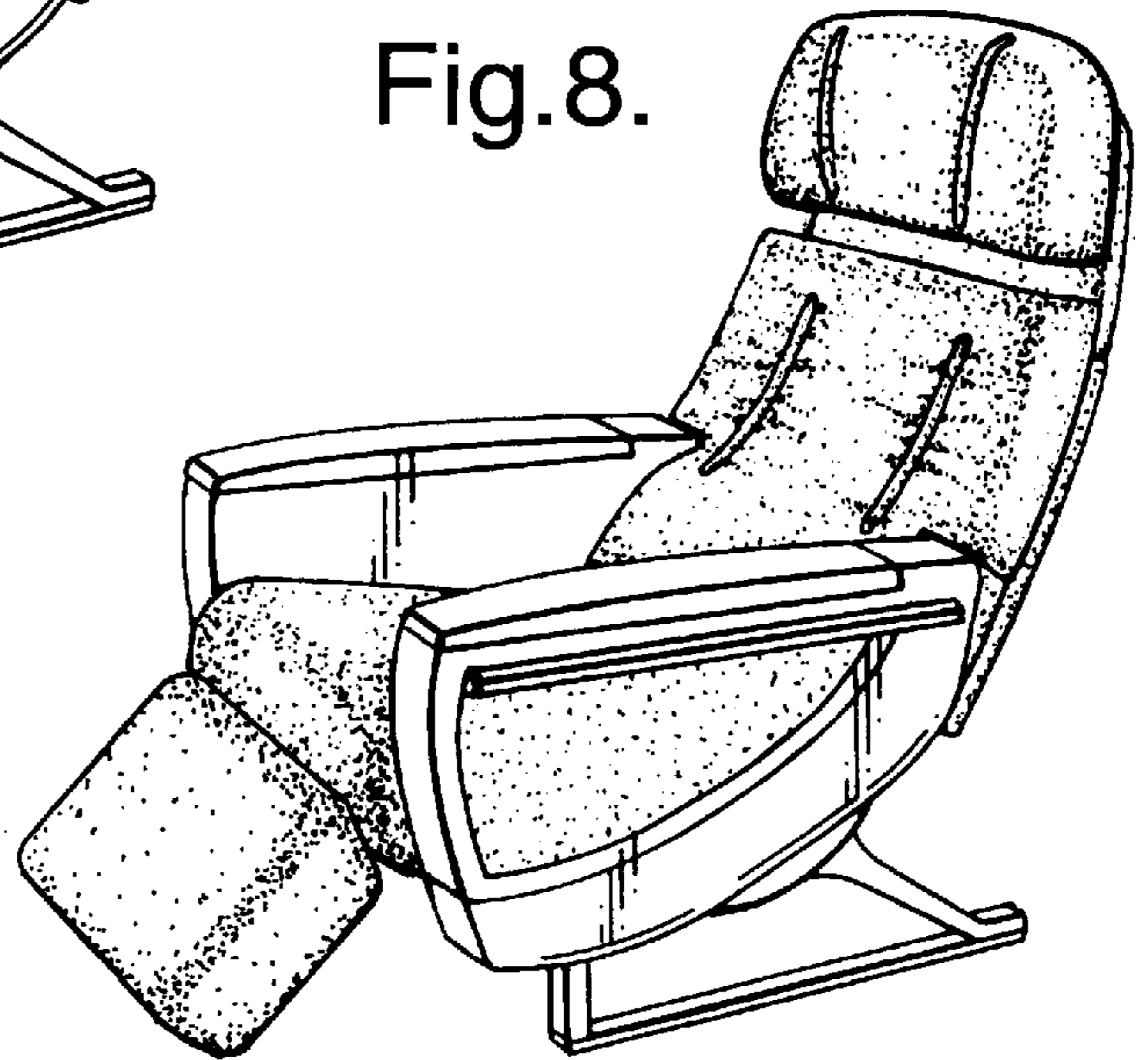

Fig.9.

