



US00D411815S

United States Patent [19]

Yamamoto et al.

[11] Patent Number: **Des. 411,815**

[45] Date of Patent: **** Jul. 6, 1999**

[54] **AUTOMOBILE**

FOREIGN PATENT DOCUMENTS

[75] Inventors: **Yutaka Yamamoto; Tetsuya Ozasa; Toshihiko Ogura; Tsutomu Musashiya; Masaya Suzuki**, all of Hamamatsu, Japan

890341	12/1994	Japan .
927883	3/1995	Japan .
786891	5/1997	Japan .
988402	5/1997	Japan .
1004783	12/1997	Japan .

[73] Assignee: **Suzuki Motor Corporation**, Shizuoka-ken, Japan

Primary Examiner—Melody N. Brown
Attorney, Agent, or Firm—Gary M. Nath; Nath & Associates

[**] Term: **14 Years**

[57] CLAIM

[21] Appl. No.: **29/086,531**

The ornamental design for an automobile, as shown and described.

[22] Filed: **Apr. 15, 1998**

[30] Foreign Application Priority Data

DESCRIPTION

Oct. 17, 1997 [JP] Japan 9-71789

FIG. 1 is a front and right-side perspective view of an automobile showing our new design;
FIG. 2 is a rear and left-side perspective view thereof;
FIG. 3 is a front elevational view thereof;
FIG. 4 is a rear elevational view thereof;
FIG. 5 is a right-side view thereof;
FIG. 6 is a left-side view thereof.
FIG. 7 is a top plan view thereof; and,
FIG. 8 is a bottom view thereof.

[51] **LOC (6) Cl.** **12-08**

[52] **U.S. Cl.** **D12/91**

[58] **Field of Search** D12/90-92; 296/185

[56] References Cited

U.S. PATENT DOCUMENTS

D. 396,203	7/1998	Uematsu et al.	D12/91
D. 401,185	11/1998	McGovern	D12/91
D. 403,989	1/1999	Honda et al.	D12/91

1 Claim, 7 Drawing Sheets

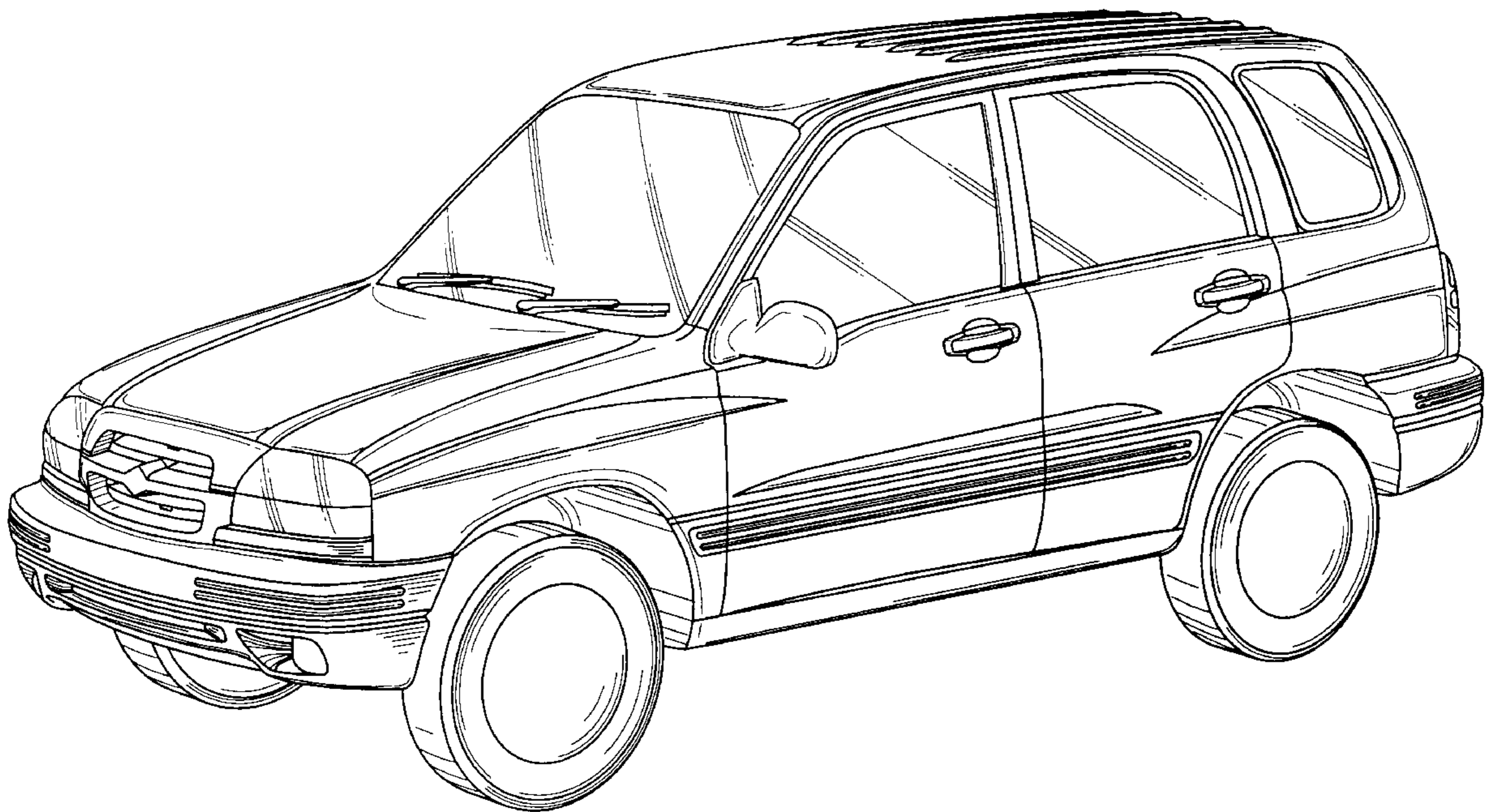

FIG. 1

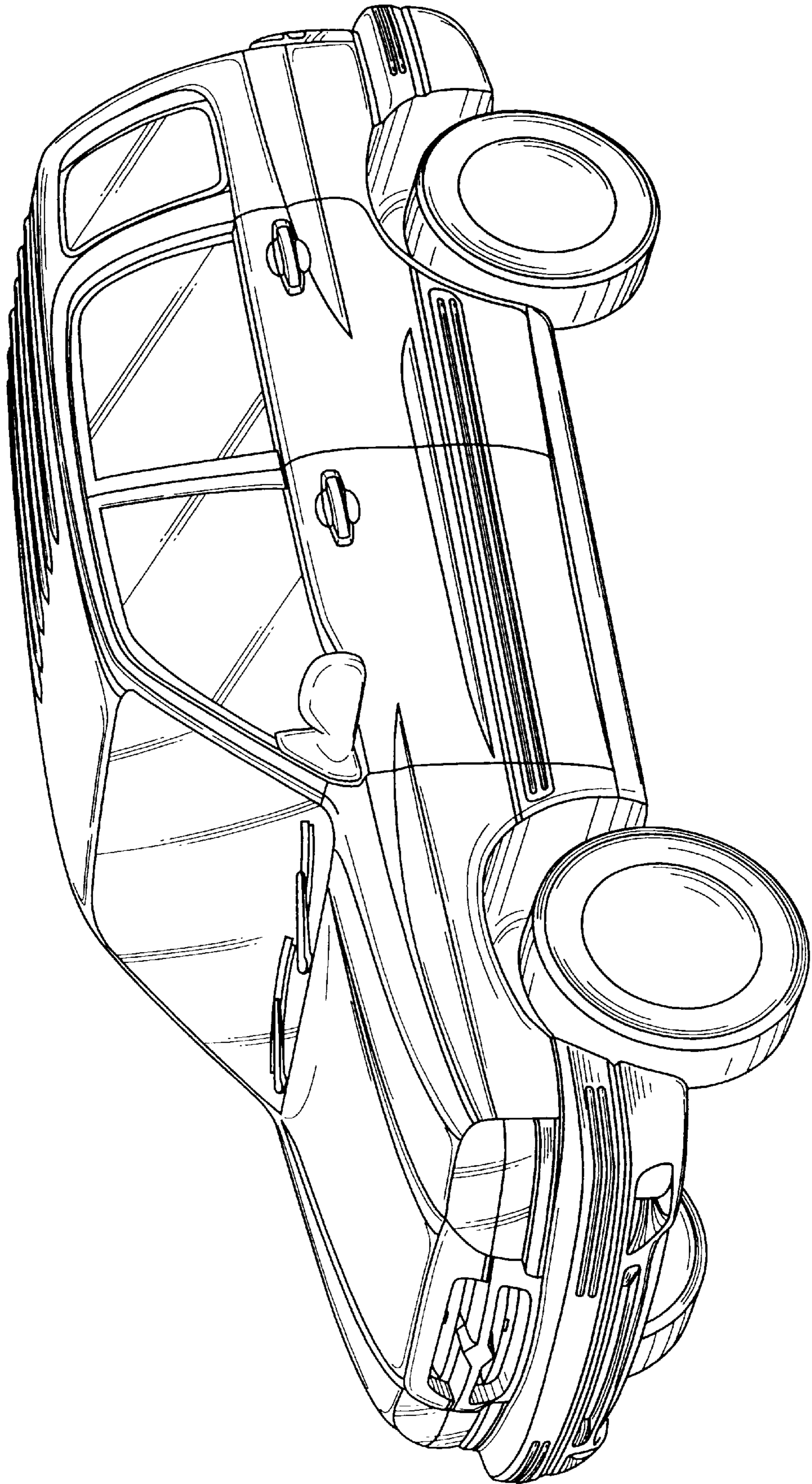

FIG. 2

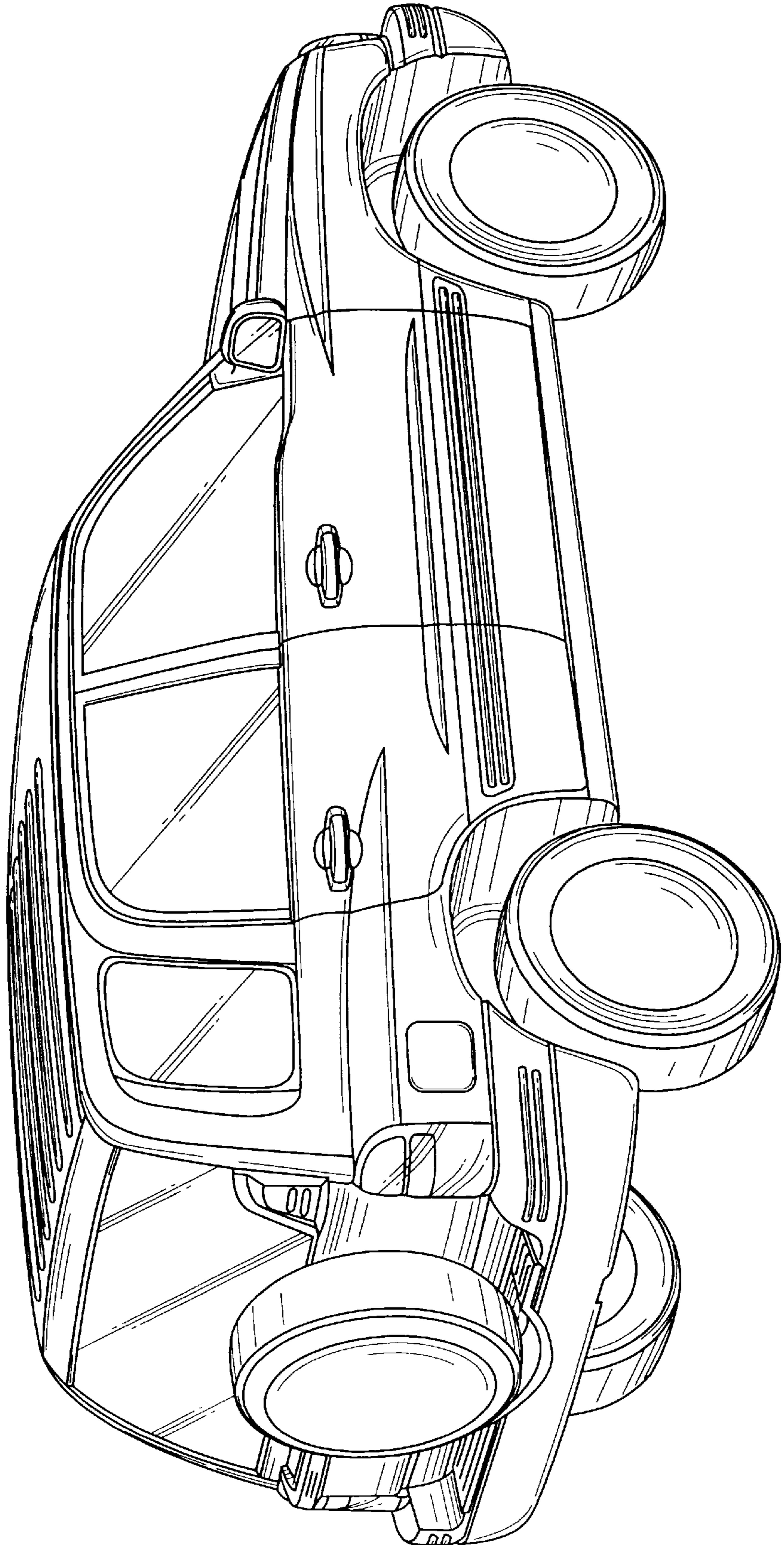

FIG. 3

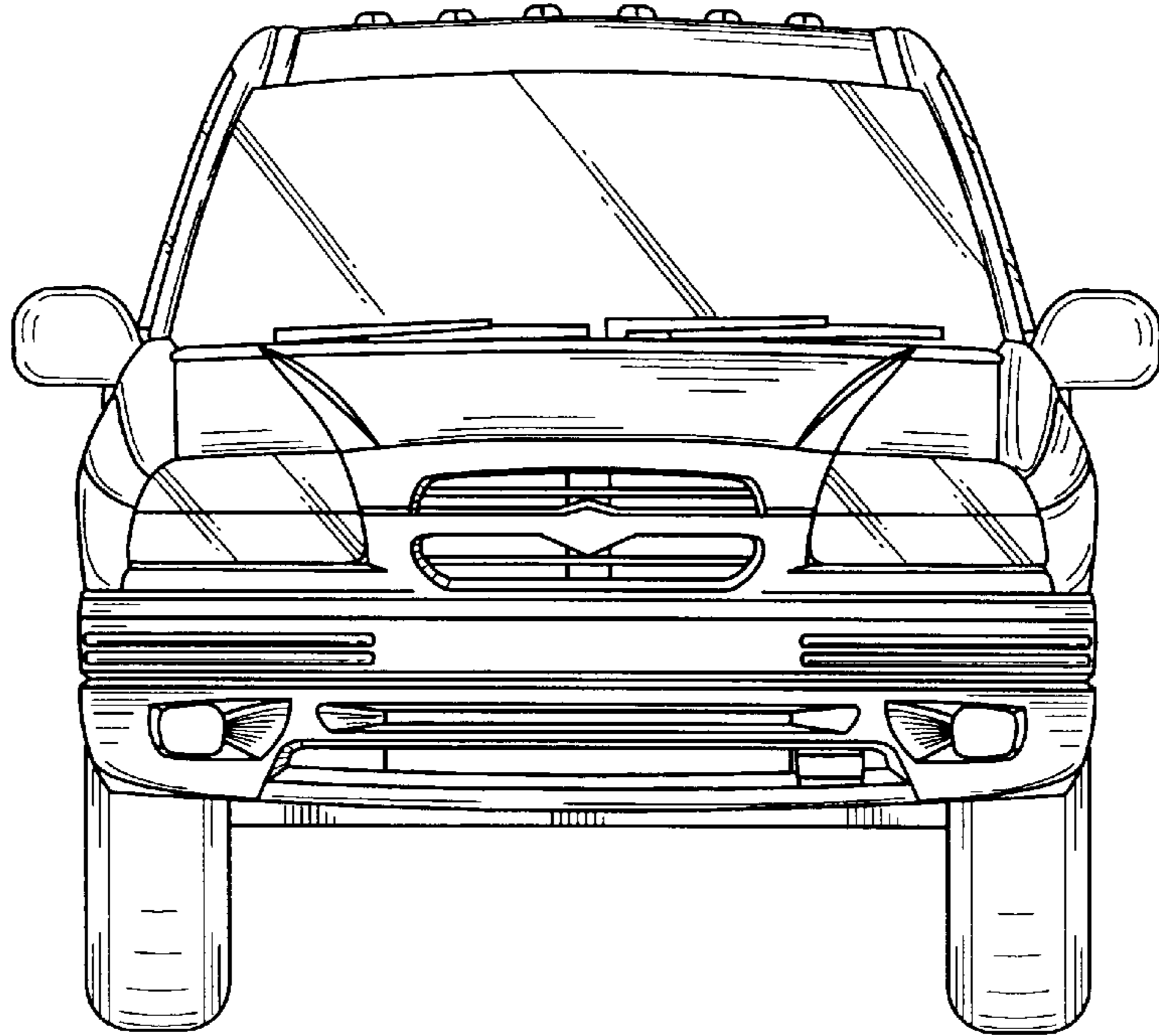

FIG. 4

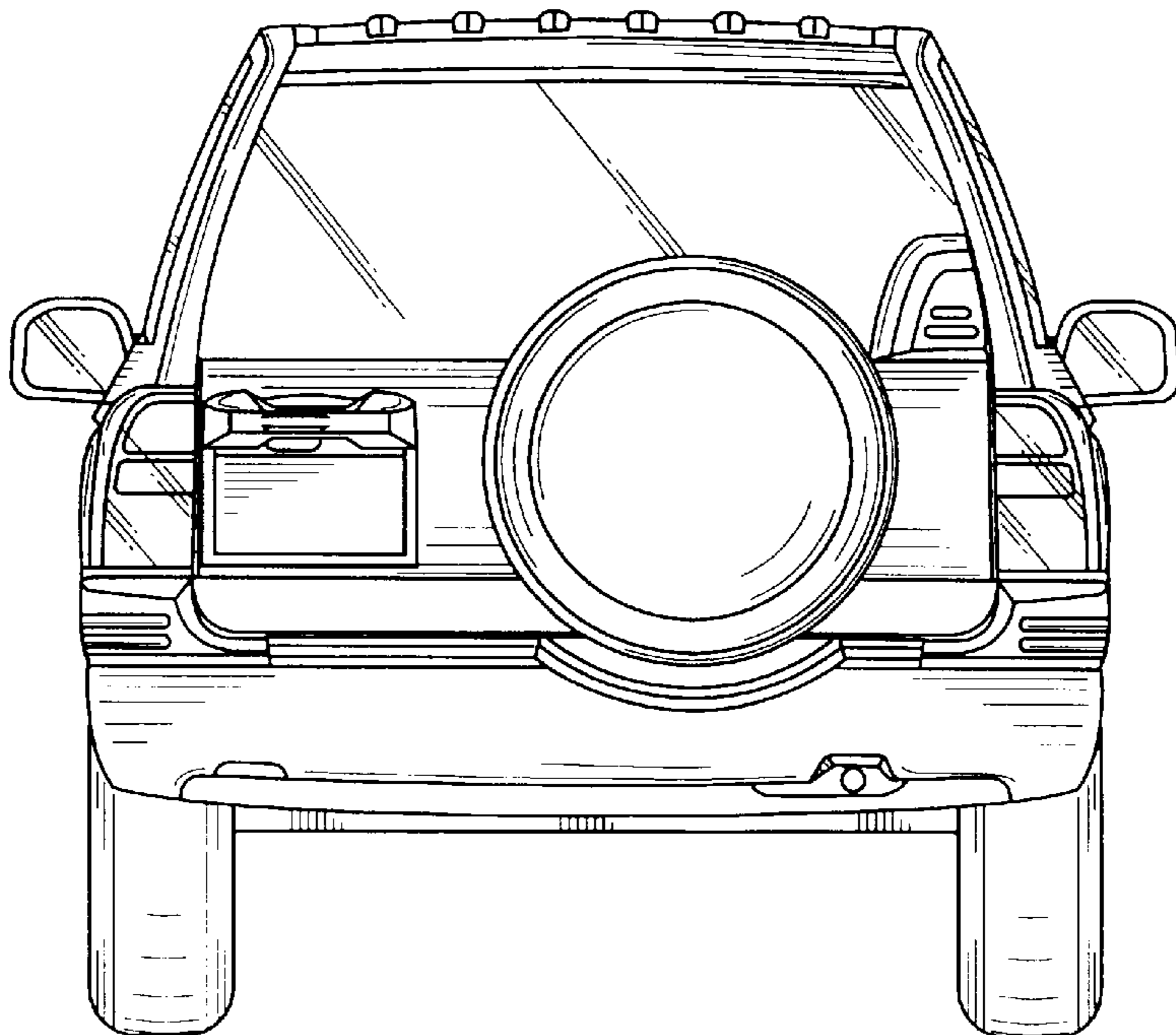

FIG. 5

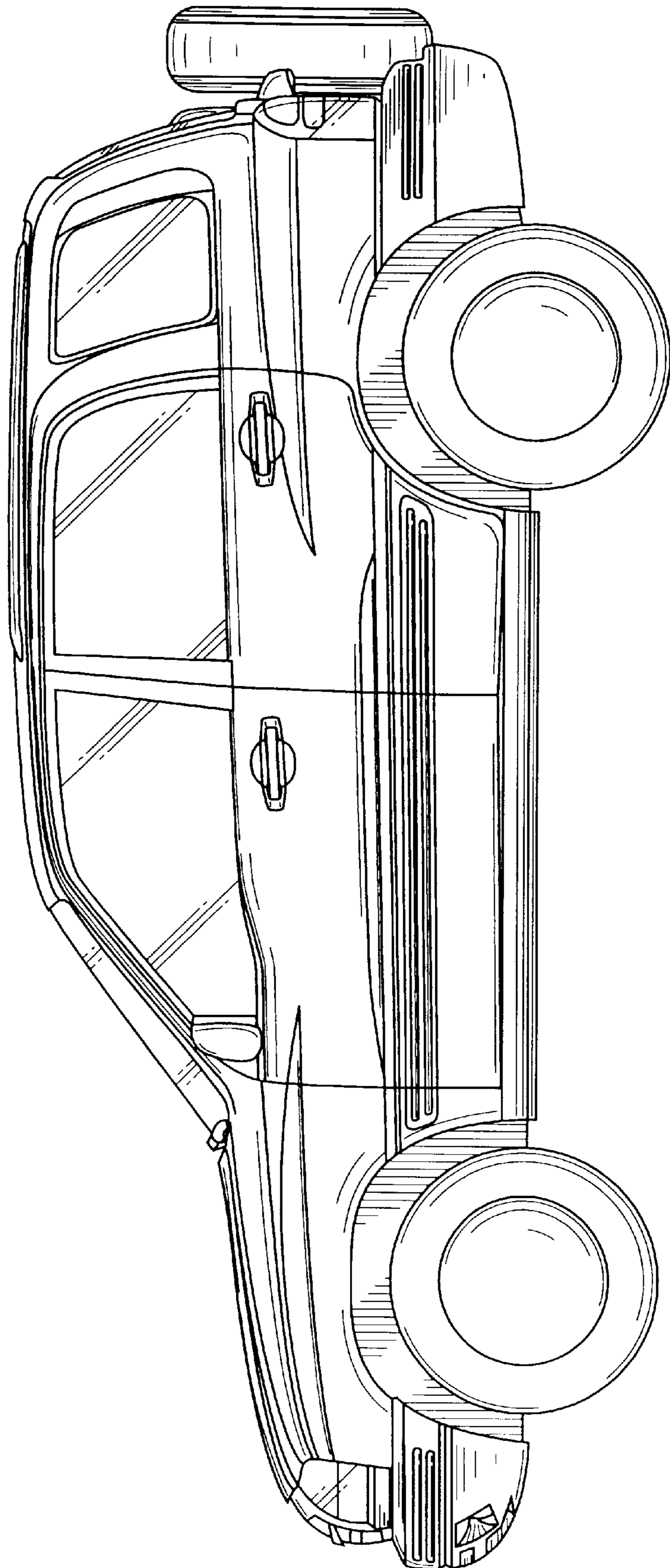

FIG. 6

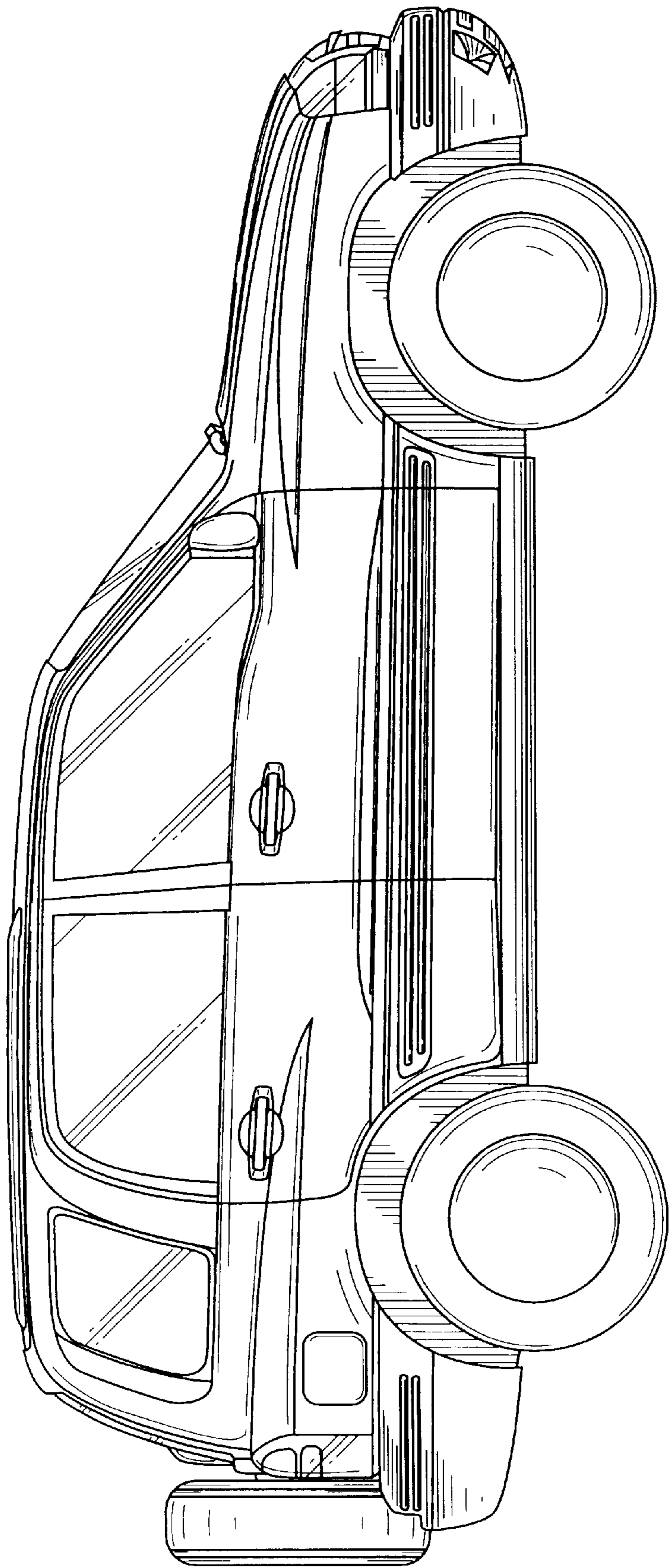

FIG. 7

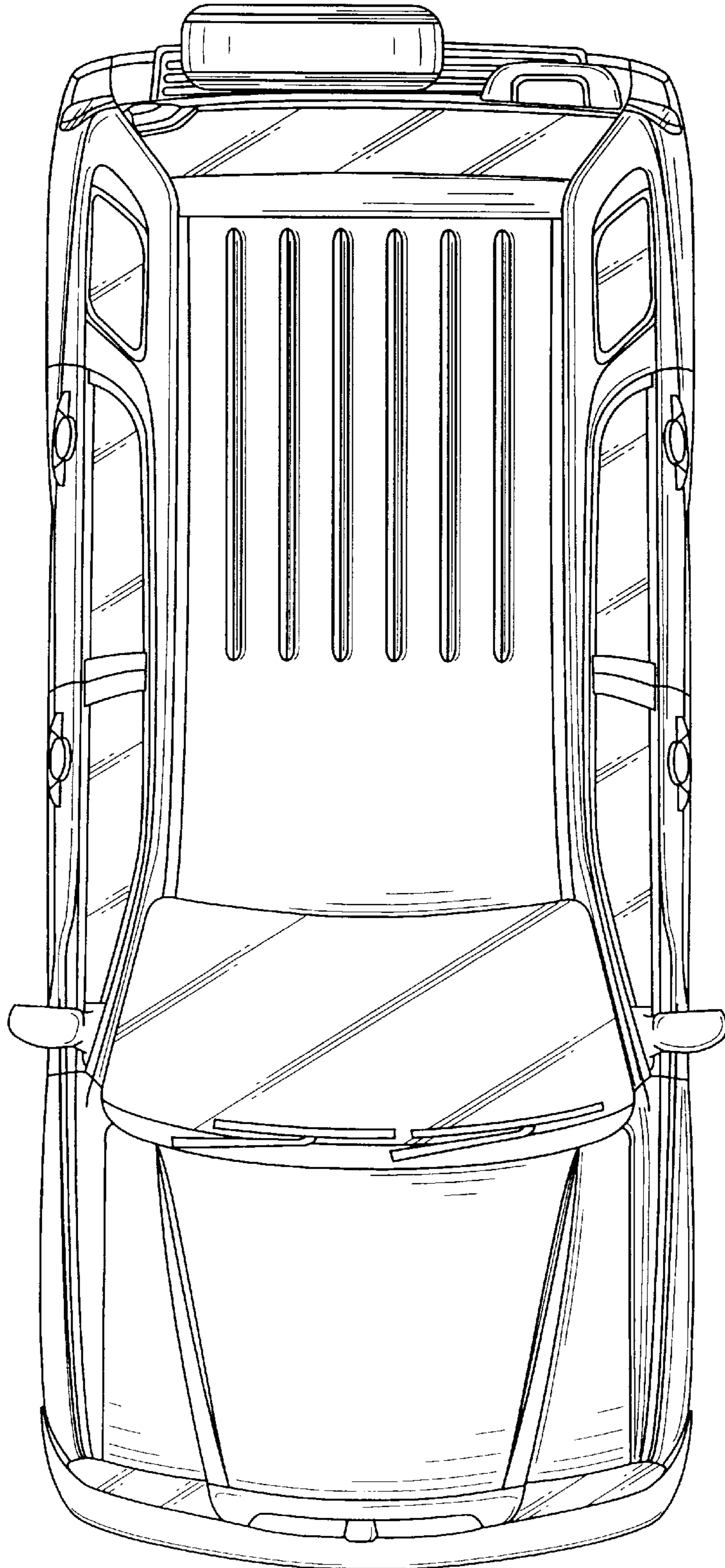

FIG. 8

