



US00D411814S

United States Patent [19]

Chibuka et al.

[11] Patent Number: **Des. 411,814**

[45] Date of Patent: **** Jul. 6, 1999**

[54] **AUTOMOBILE**

[75] Inventors: **Shinri Chibuka; Youji Hayashi; Masashi Shimada; Keisuke Asai**, all of Wako, Japan

[73] Assignee: **Honda Giken Kogyo Kabushiki Kaisha**, Tokyo, Japan

[**] Term: **14 Years**

[21] Appl. No.: **29/092,369**

[22] Filed: **Aug. 18, 1998**

[30] Foreign Application Priority Data

Mar. 11, 1998 [JP] Japan H10-6949

[51] **LOC (6) Cl.** **12-08**

[52] **U.S. Cl.** **D12/90**

[58] **Field of Search** D12/86, 90-92; 296/185

[56] References Cited

U.S. PATENT DOCUMENTS

D. 350,503 9/1994 Yang D12/90

D. 352,482 11/1994 Cannara et al. D12/90
D. 367,440 2/1996 Mays D12/90
D. 378,906 4/1997 Nesbitt et al. D12/91
D. 385,220 10/1997 Worknuss D12/90

Primary Examiner—Melody N. Brown
Attorney, Agent, or Firm—Nikaido, Marmelstein, Murray & Oram LLP

[57] CLAIM

The ornamental design for, an automobile, as shown and described.

DESCRIPTION

FIG. 1 is a right-front perspective view of an automobile, showing our new design;
FIG. 2 is a right-rear perspective view thereof,
FIG. 3 is a front view thereof;
FIG. 4 is a rear view thereof;
FIG. 5 is a right side view thereof and
FIG. 6 is a left side view of thereof; and,
FIG. 7 is a top plan view thereof.

1 Claim, 6 Drawing Sheets

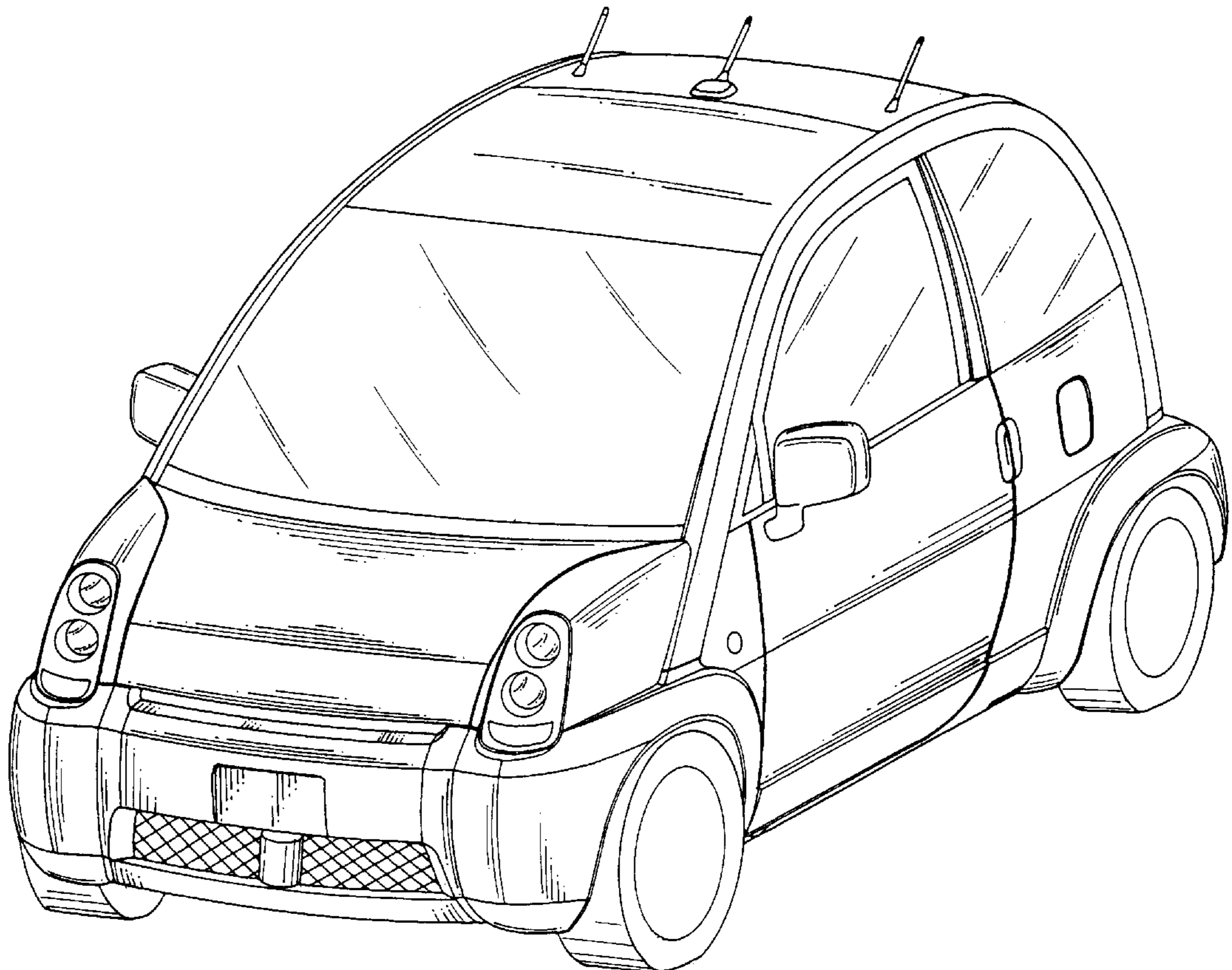

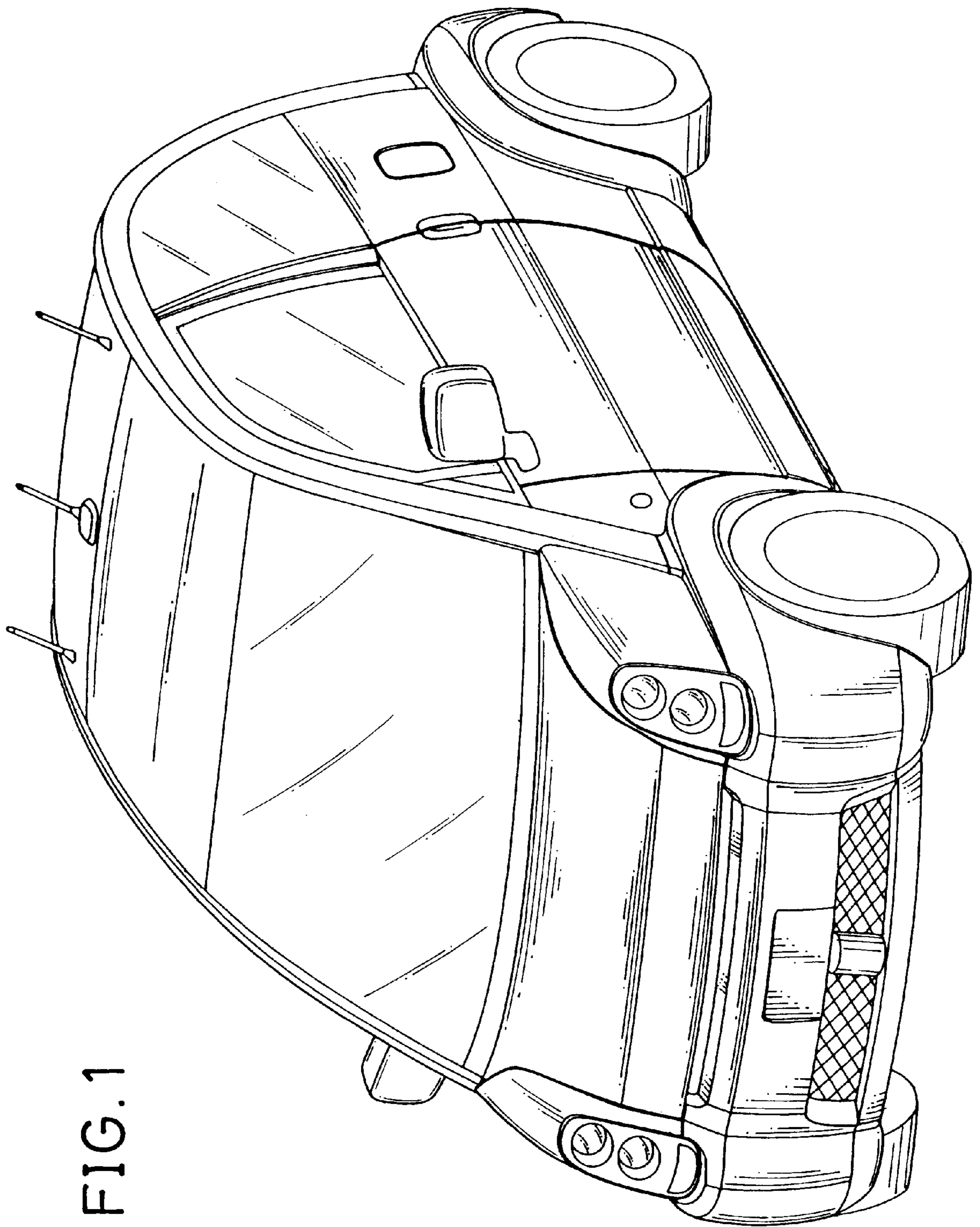

FIG. 1

FIG. 2

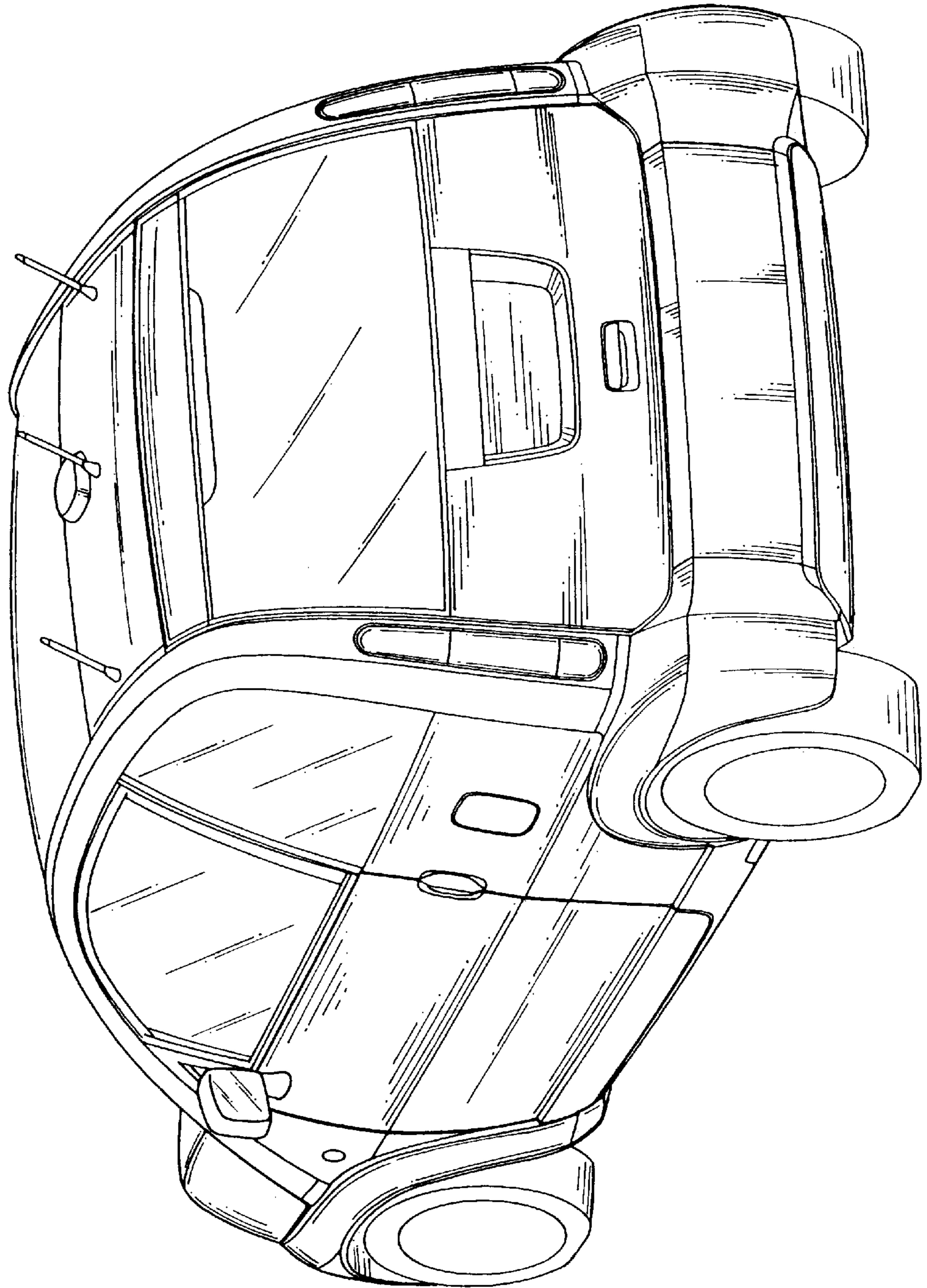

FIG. 4

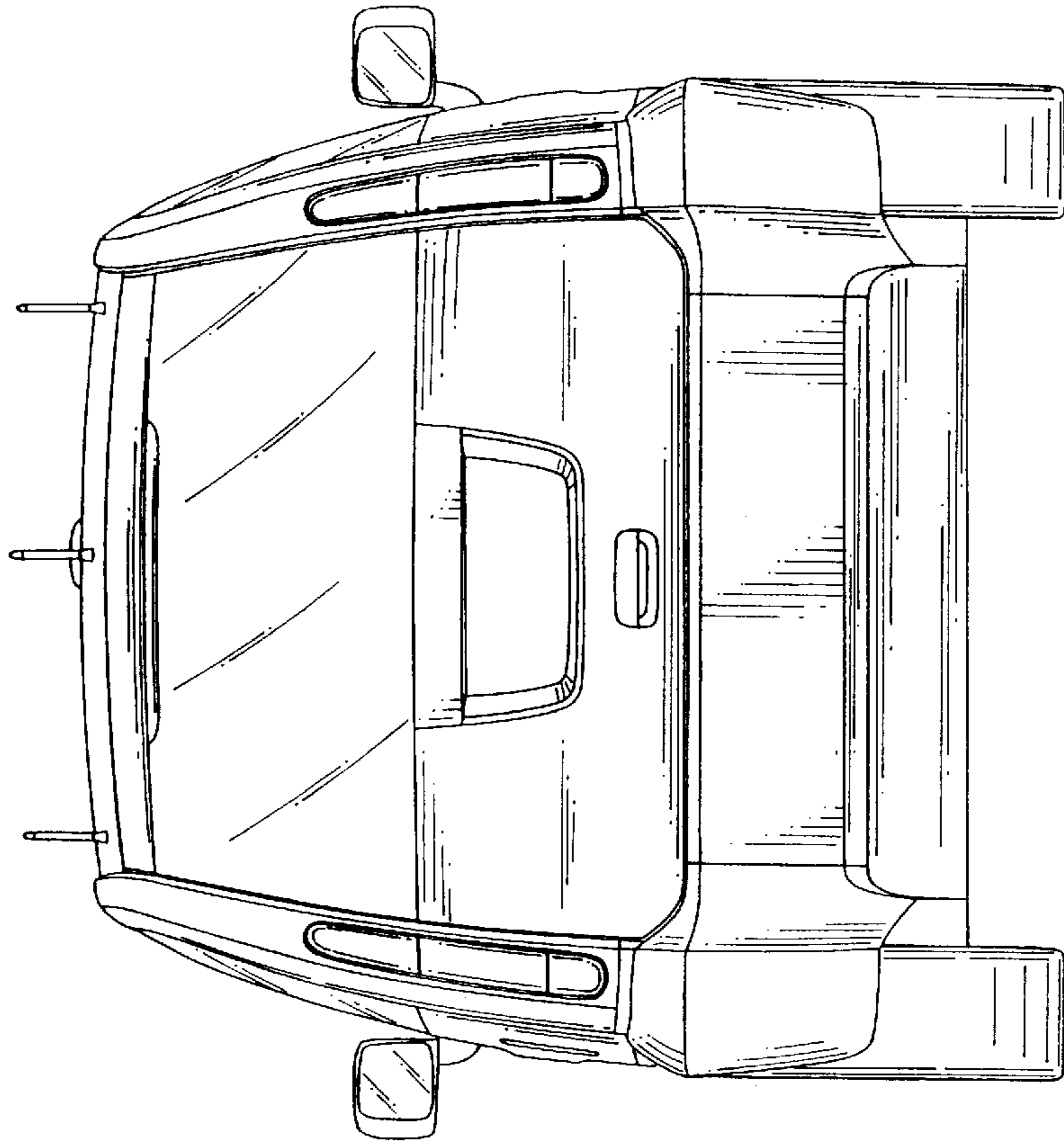

FIG. 3

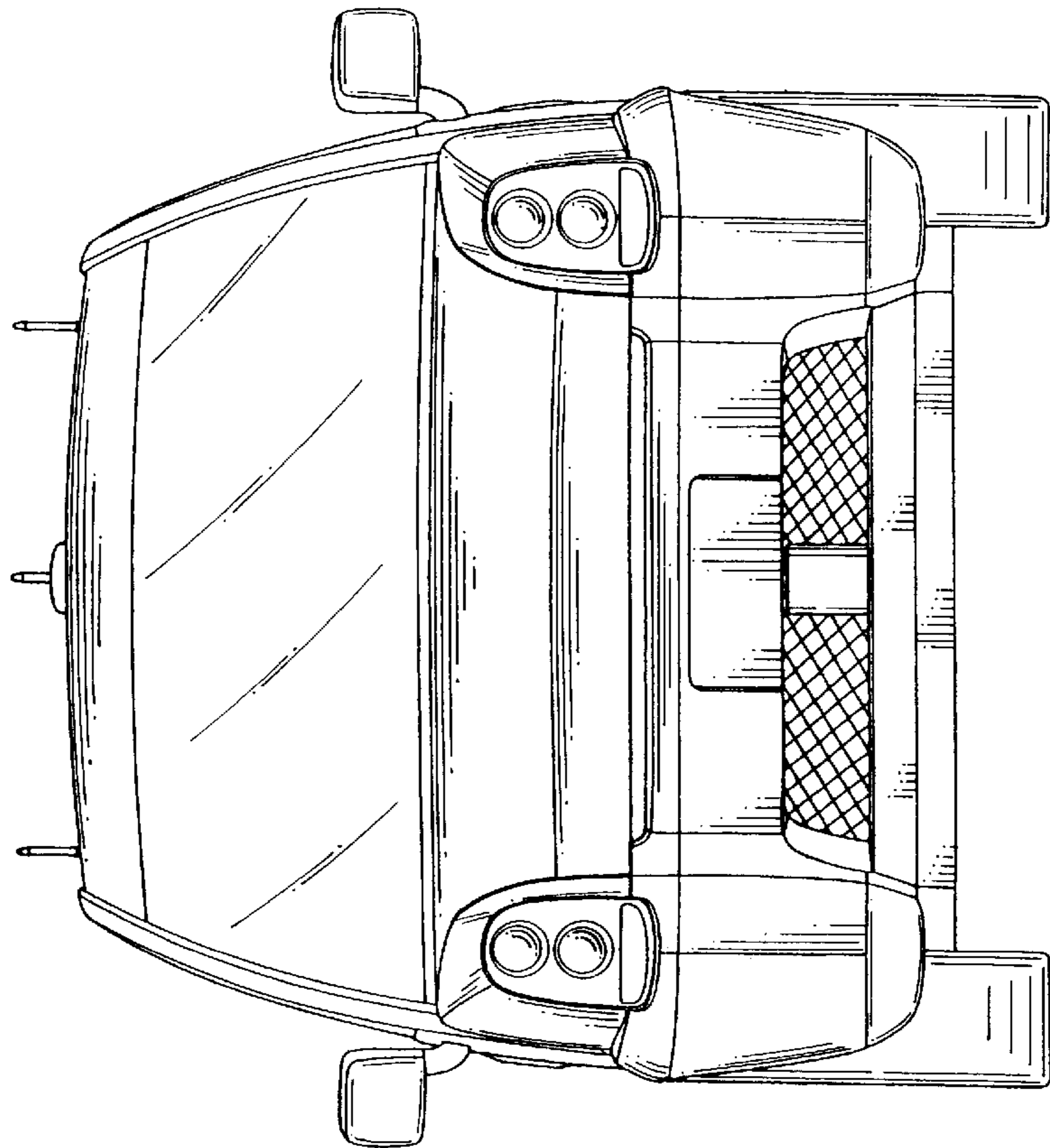

FIG. 5

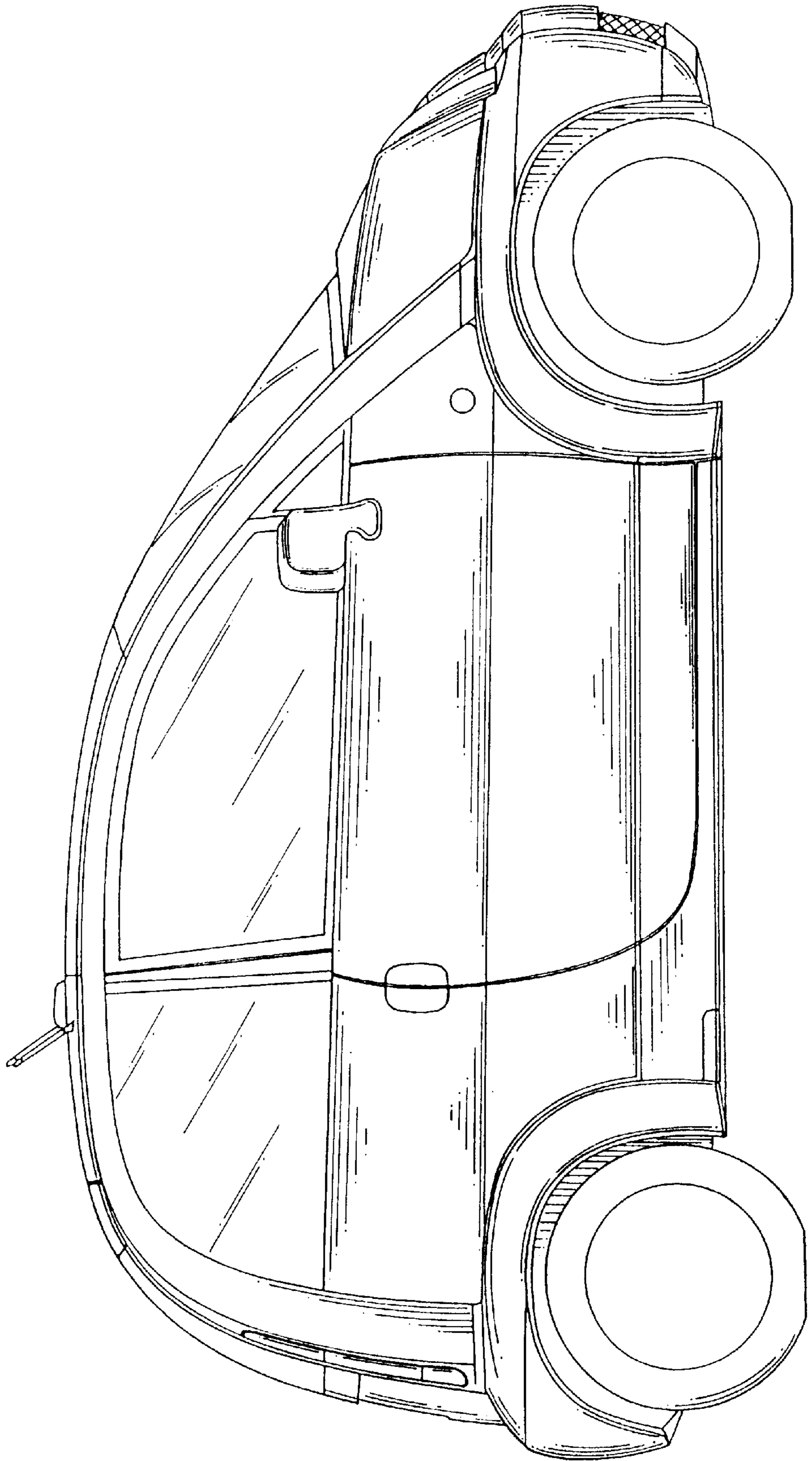

FIG. 6

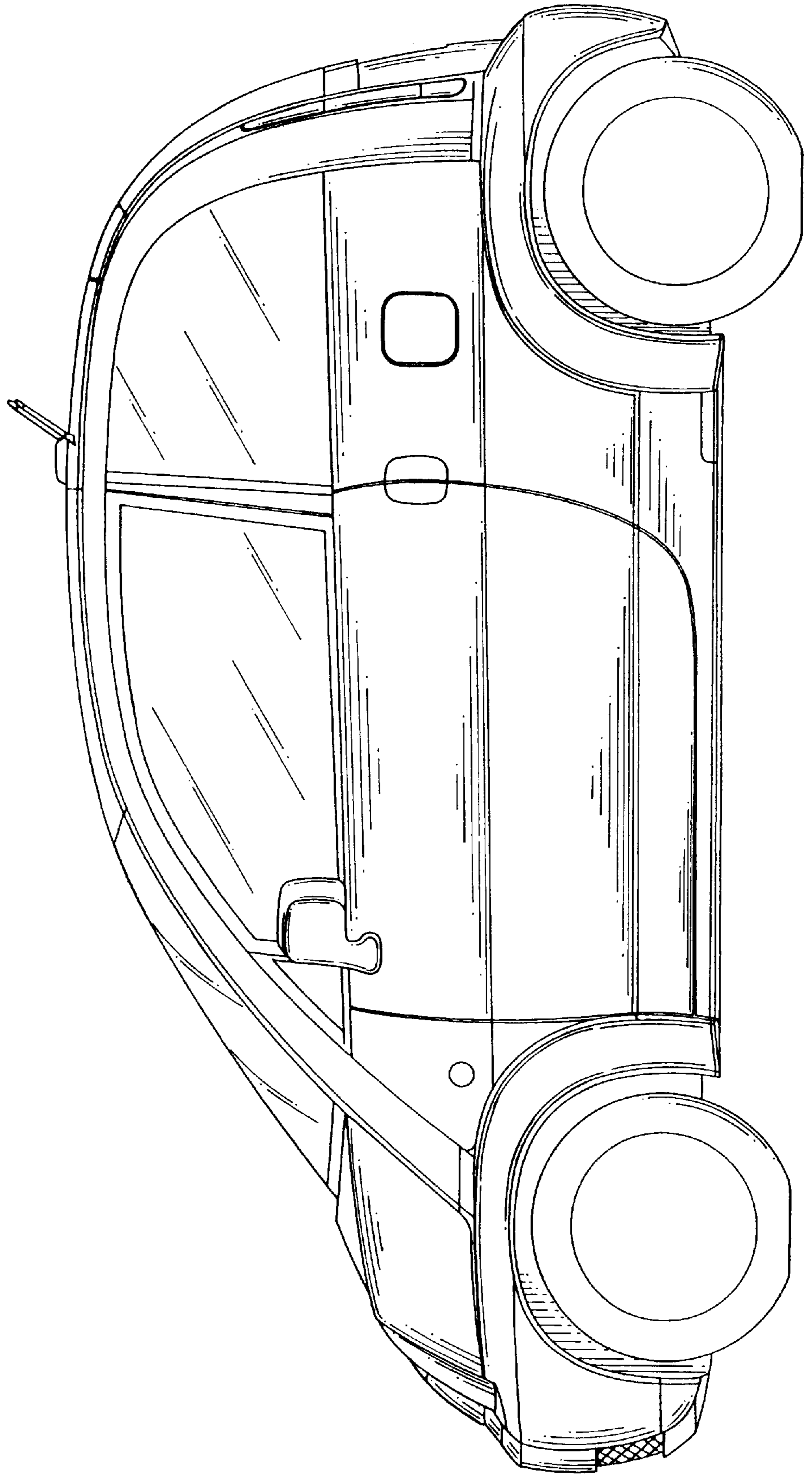

FIG. 7

