



US00D411655S

United States Patent [19] Tung

[11] **Patent Number: Des. 411,655**

[45] **Date of Patent: ** Jun. 29, 1999**

[54] **UMBRELLA CRANK HOUSING**

[76] Inventor: **Benson Tung**, No. 587, Chien-Gong Road, San-Min, Kaohsiung, Taiwan

[**] Term: **14 Years**

[21] Appl. No.: **29/091,769**

[22] Filed: **Aug. 5, 1998**

[51] **LOC (6) Cl. 03-03**

[52] **U.S. Cl. D3/10**

[58] **Field of Search** D3/5, 6, 7, 10, D3/12; 135/20.3, 22-28, 38, 39, 44, 98

[56] **References Cited**

U.S. PATENT DOCUMENTS

D. 285,862	9/1986	Levy	D3/10
D. 292,947	12/1987	Levy	D3/10
4,878,509	11/1989	Tung	135/20.3
5,711,333	1/1998	Vanderminde, Sr.	135/20.3

Primary Examiner—Louis S. Zarfes
Assistant Examiner—Catherine R. Oliver
Attorney, Agent, or Firm—Rosenberg, Klein & Bilker

[57] **CLAIM**

The ornamental design for an umbrella crank housing, as shown and described.

DESCRIPTION

FIG. 1 is a perspective view of an umbrella crank housing showing may design;
FIG. 2 is a front elevational view thereof;
FIG. 3 is rear elevational view thereof;
FIG. 4 is a left elevational view thereof;
FIG. 5 is a right elevational view thereof;
FIG. 6 is a top plan view thereof;
FIG. 7 is a bottom plan view thereof; and,
FIG. 8 is a perspective view illustrating an umbrella with the umbrella crank housing, the phantom lines being for illustrative purposes only and forming no part of the claimed design.

1 Claim, 4 Drawing Sheets

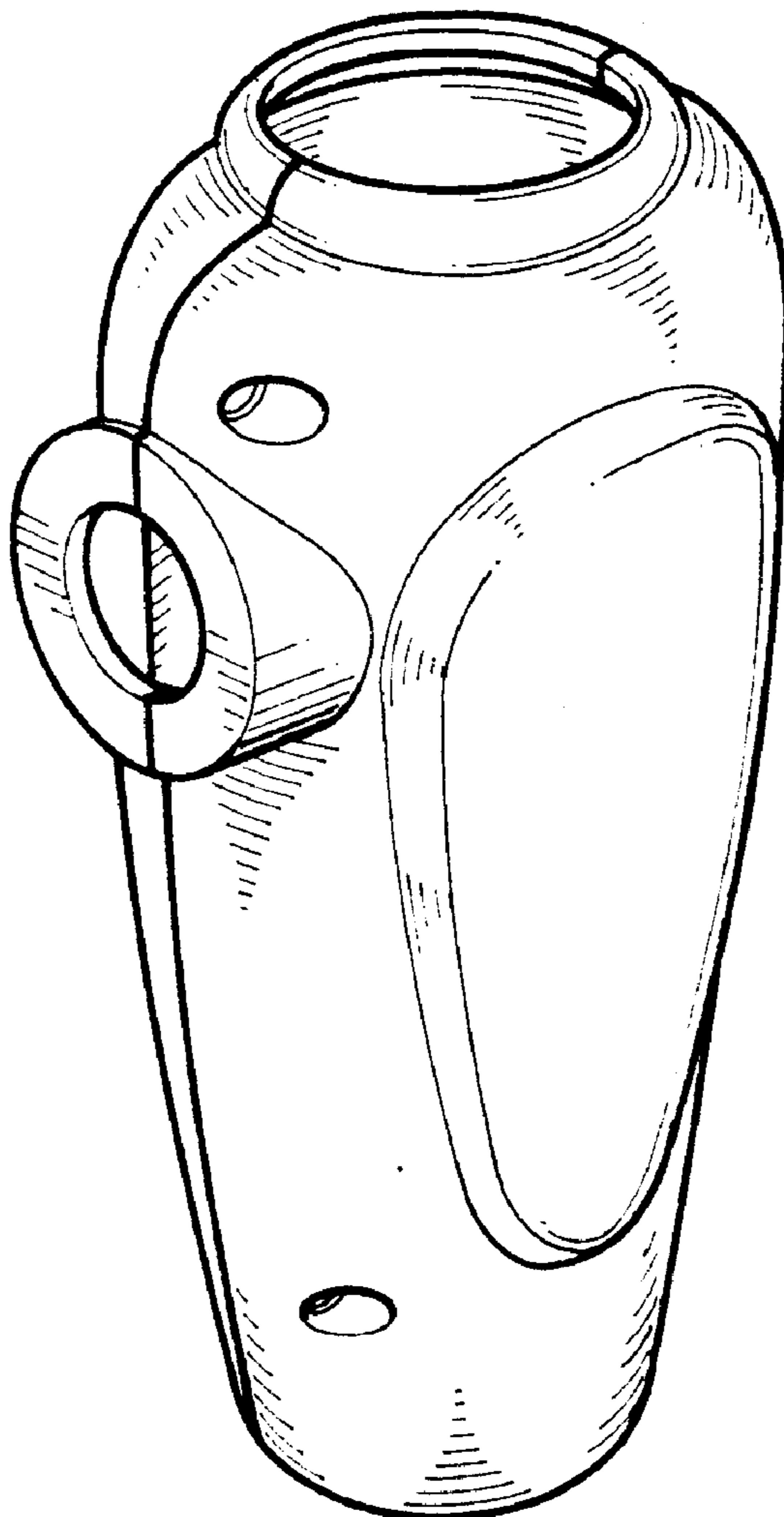

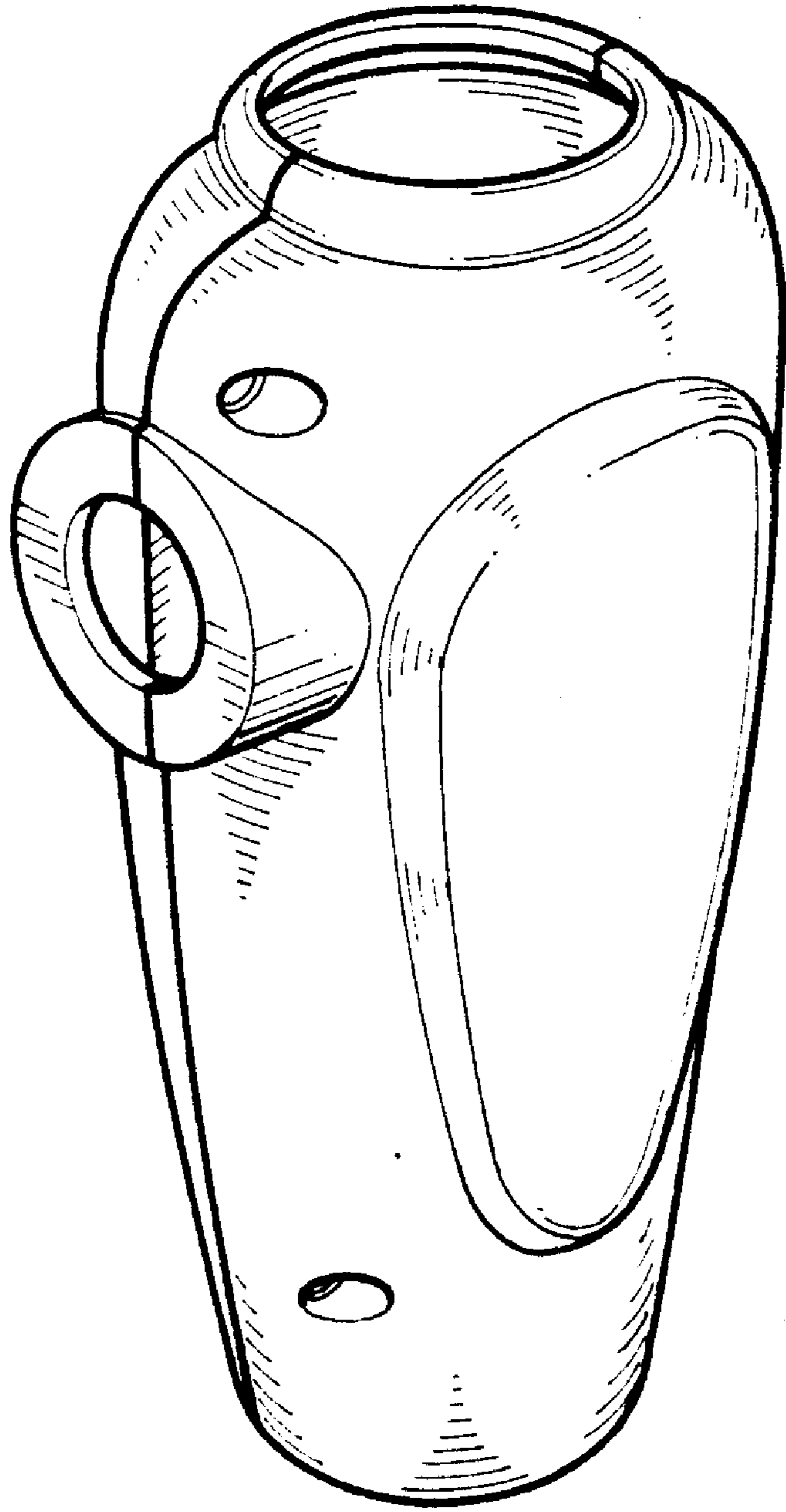

FIG. 1

FIG. 5

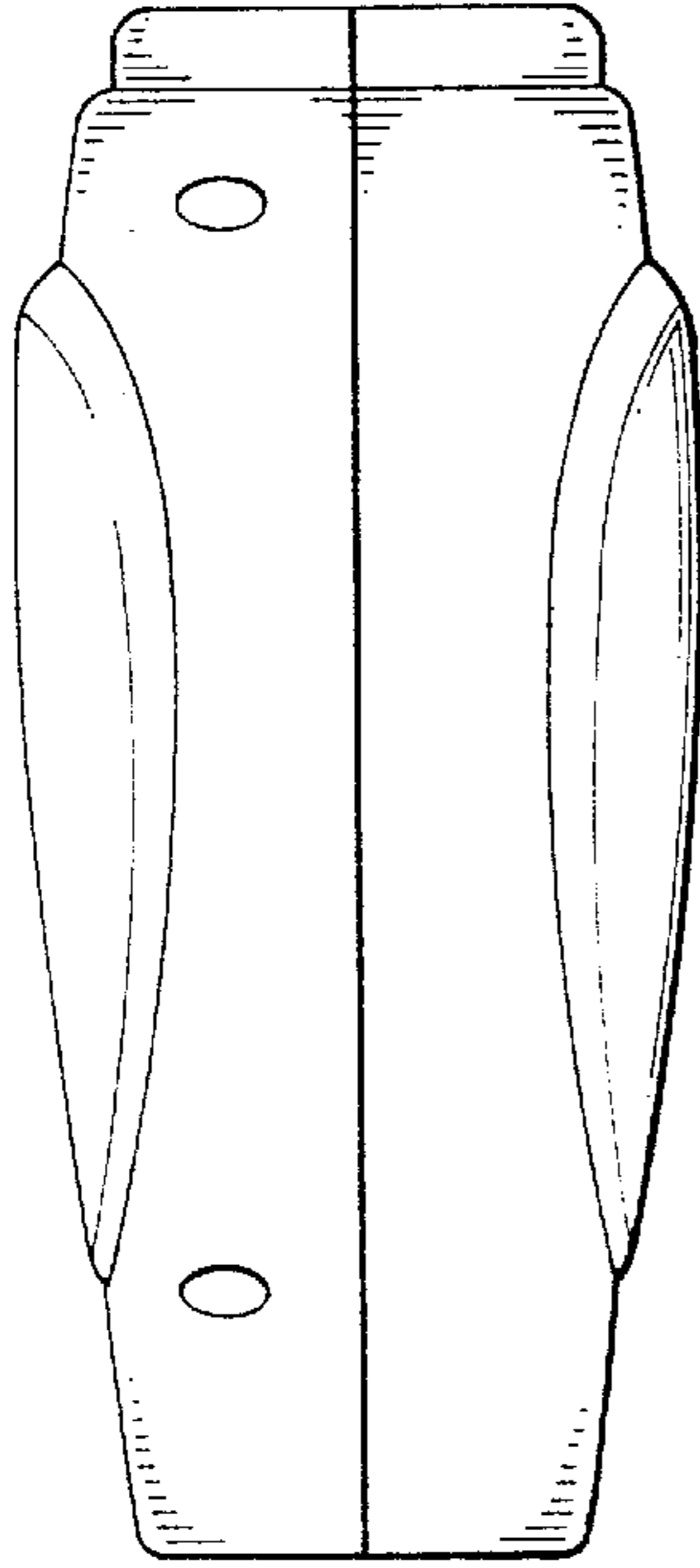

FIG. 2

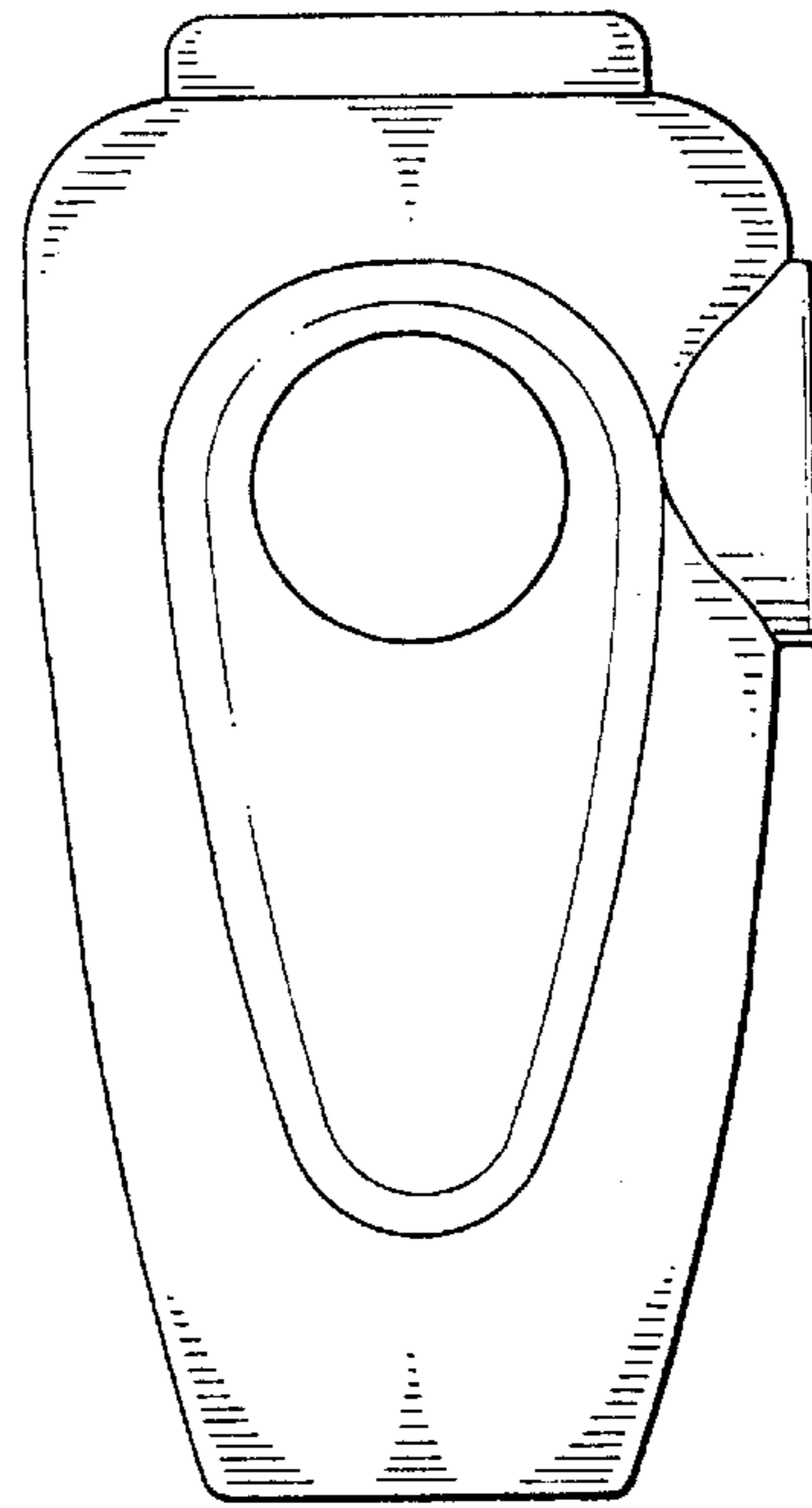
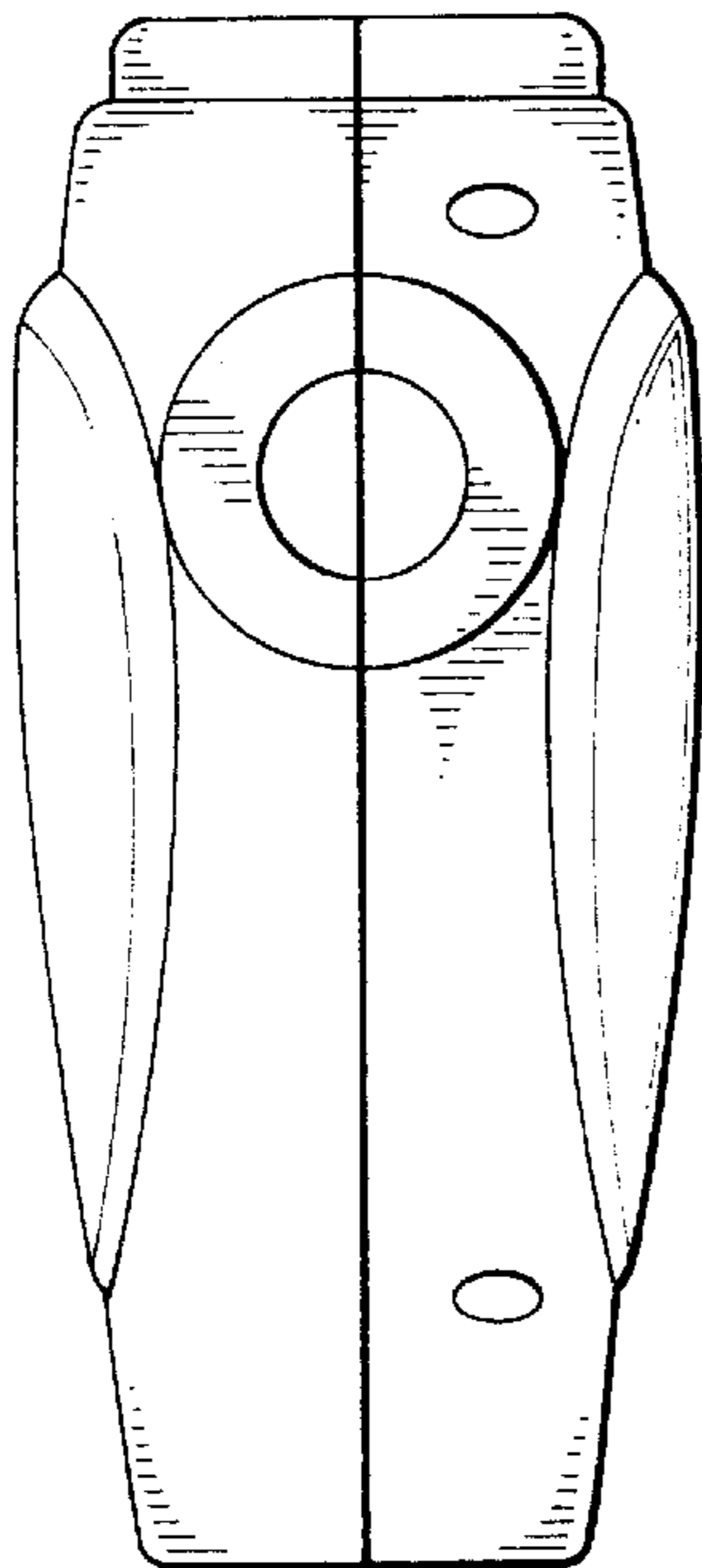
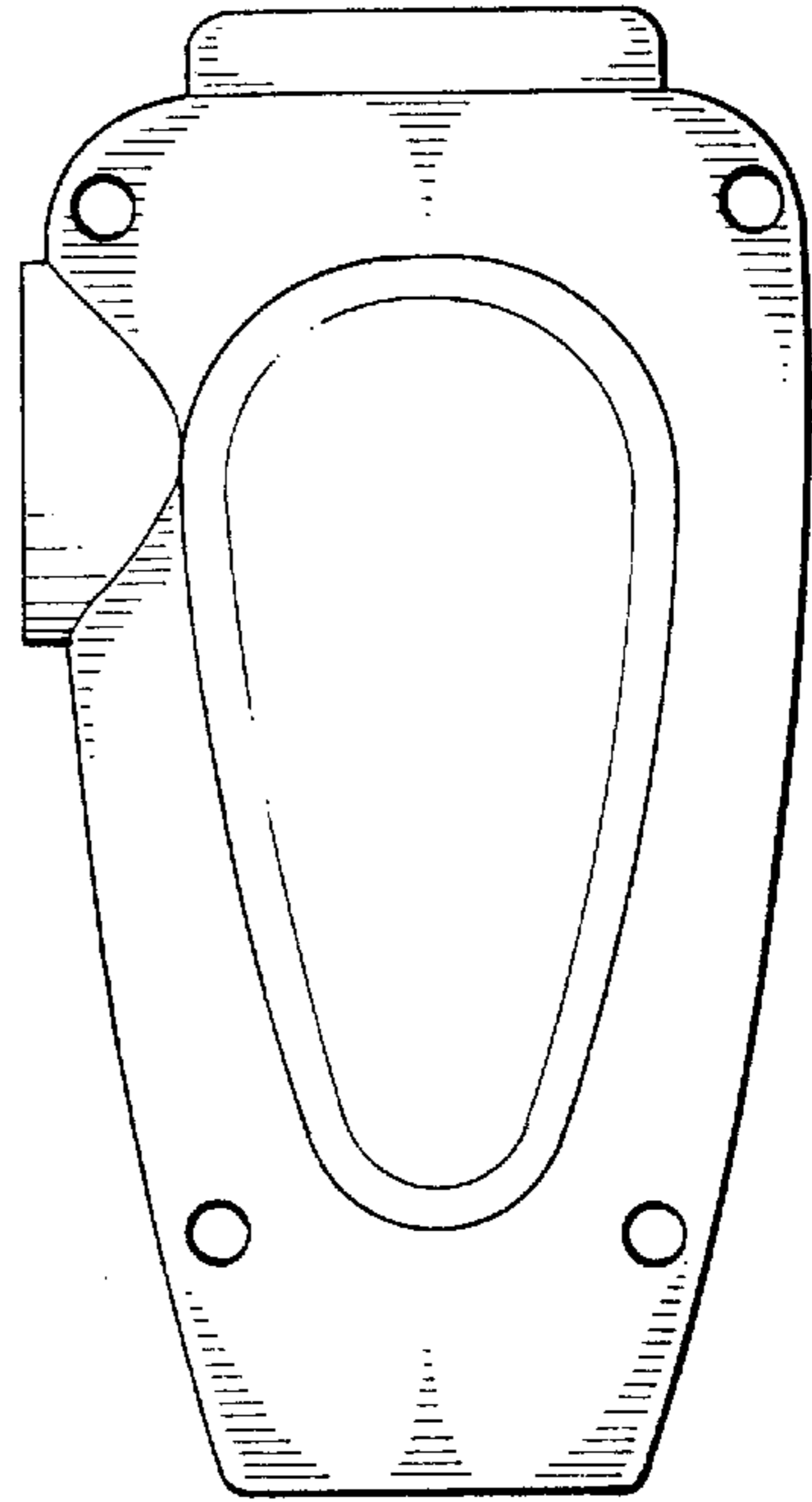

FIG. 4

FIG. 3

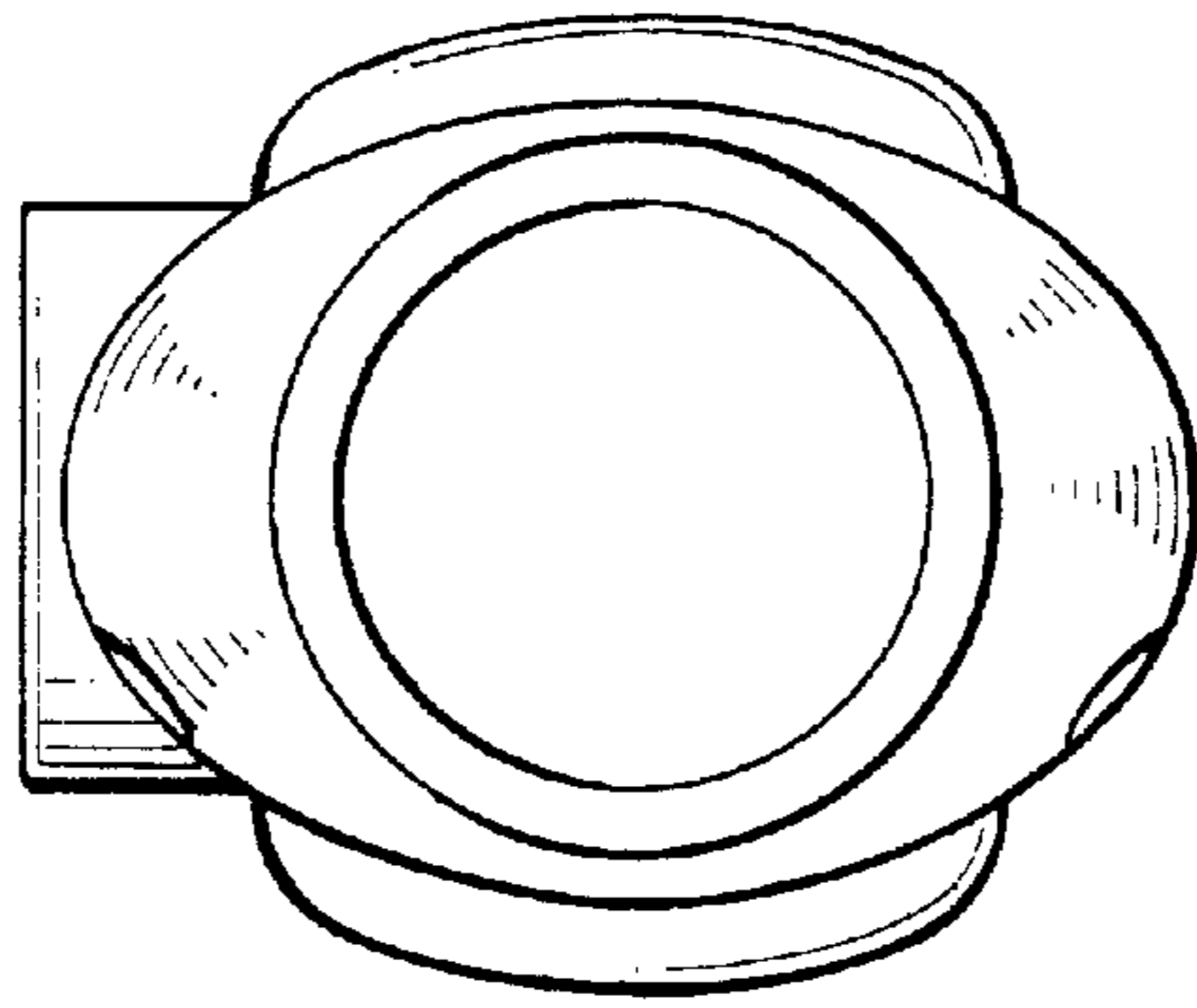

FIG. 6

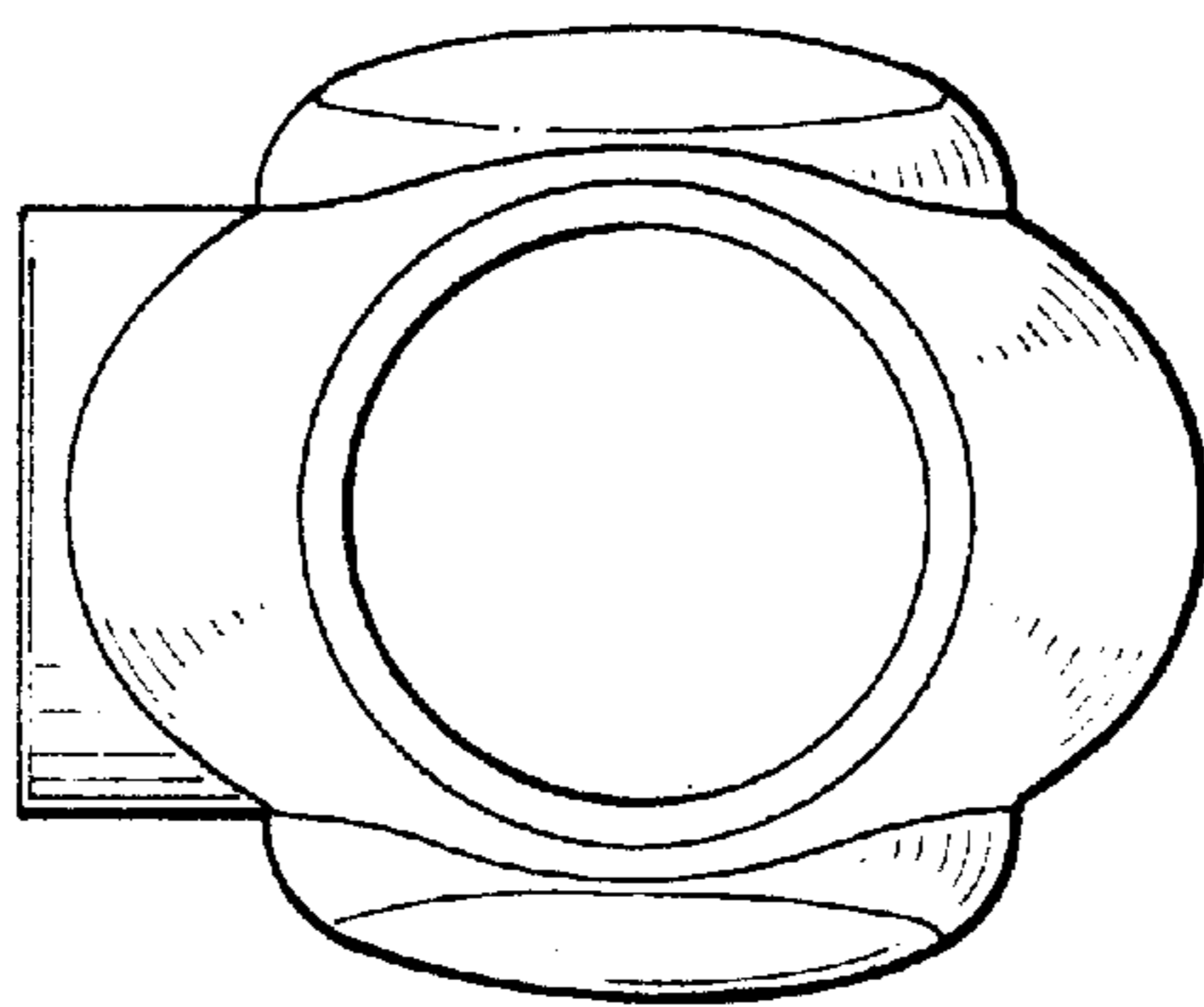

FIG. 7

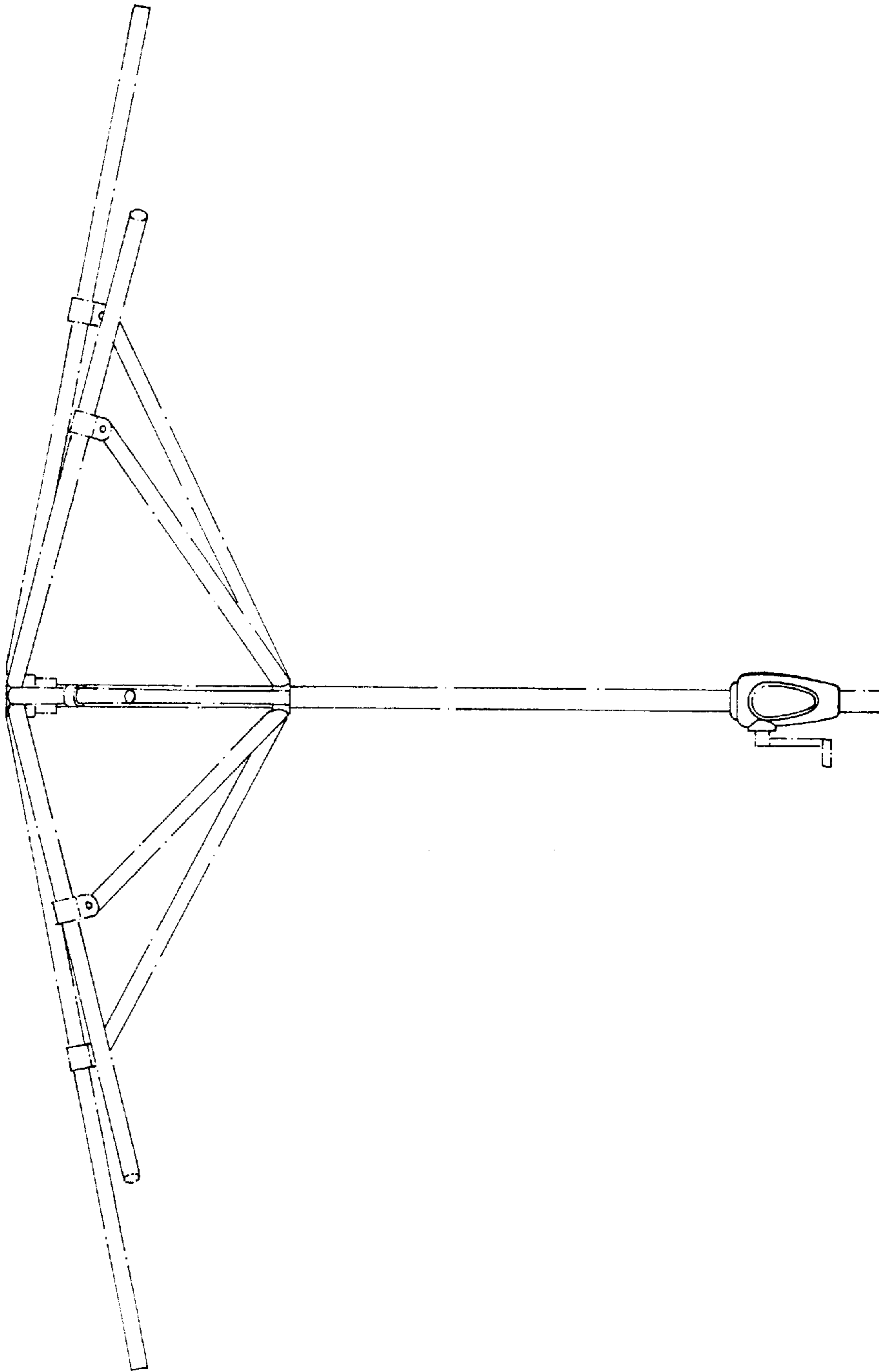

FIG. 8