



US00D411363S

# United States Patent [19]

[11] Patent Number: Des. 411,363

Black et al.

[45] Date of Patent: \*\* Jun. 22, 1999

[54] SINGLE-DIRECTION DIVERTING PUSHER ELEMENT FOR A SORTING CONVEYOR

5,595,279 1/1997 Wilkins et al. .

[75] Inventors: Paul L. Black, Norwood; Martin A. Heit, Cincinnati; David W. Hawke, Lebanon; James W. Halsey, Forest Park; Allen C. Brown, West Chester; Raymond R. Neiser, Batavia, all of Ohio

Primary Examiner—Susan J. Lucas  
Assistant Examiner—Cynthia E. Ramirez  
Attorney, Agent, or Firm—Frost & Jacobs LLP

[73] Assignee: The Buschman Company, Cincinnati, Ohio

### [57] CLAIM

[\*\*] Term: 14 Years

The ornamental design for a single-direction diverting pusher element for a sorting conveyor, as shown and described.

[21] Appl. No.: 29/083,398

### DESCRIPTION

[22] Filed: Jan. 9, 1998

FIG. 1 is a top, front and right side perspective view of the right hand single-direction diverting pusher element for a sorting conveyor of the present invention showing our new design

[51] LOC (6) Cl. .... 12-05

[52] U.S. Cl. .... D34/29

FIG. 2 is a left side elevational view of the pusher element of FIG. 1.

[58] Field of Search ..... D34/29, 35; 198/370.02, 198/890, 890.1, 367, 440, 456

FIG. 3 is a top plan view of the pusher element of FIG. 1. FIG. 4 is a right side elevational view of the pusher element of FIG. 1.

### [56] References Cited

#### U.S. PATENT DOCUMENTS

D. 311,200	10/1990	Nakayama et al. ....	D8/349 X
D. 332,338	1/1993	McDonald et al. ....	D34/35
D. 386,874	11/1997	Glaun .....	D34/29
D. 388,583	12/1997	Glaun .....	D34/29
3,273,693	9/1966	Vom Dorp .	
3,361,247	1/1968	Lauzon et al. .	
3,447,659	6/1969	Mumma .	
3,987,888	10/1976	Wickam .	
4,328,889	5/1982	Maxted .....	198/367
4,711,341	12/1987	Yu et al. .	
4,738,347	4/1988	Brouwer et al. .	
4,760,908	8/1988	Houghton .	
4,884,677	12/1989	Yu et al. .	
4,896,760	1/1990	Triantafilou et al. .	
4,971,190	11/1990	Berends et al. .	
5,027,939	7/1991	Kilper et al. .	
5,127,510	7/1992	Cotter et al. .	
5,131,522	7/1992	Fujio .	
5,135,115	8/1992	Miller et al. ....	209/657 X

FIG. 5 is a front elevational view of the pusher element of FIG. 1.

FIG. 6 is a rear elevational view of the pusher element of FIG. 1.

FIG. 7 is a top, front and left side perspective view of a second embodiment of the present invention showing our new design.

FIG. 8 is a right side elevational view of the pusher element of FIG. 7.

FIG. 9 is a top plan view of the pusher element of FIG. 7.

FIG. 10 is a left side elevational view of the pusher element of FIG. 7.

FIG. 11 is a front elevational view of the pusher element of FIG. 7; and,

FIG. 12 is a rear view of the pusher element of FIG. 7.

The pusher element of FIGS. 7 through 12 is an identical mirror image of the pusher element of FIGS. 1 through 6. The bottom of the pusher element varies with the type of pusher element mount used and does not constitute a part of the invention.

1 Claim, 6 Drawing Sheets

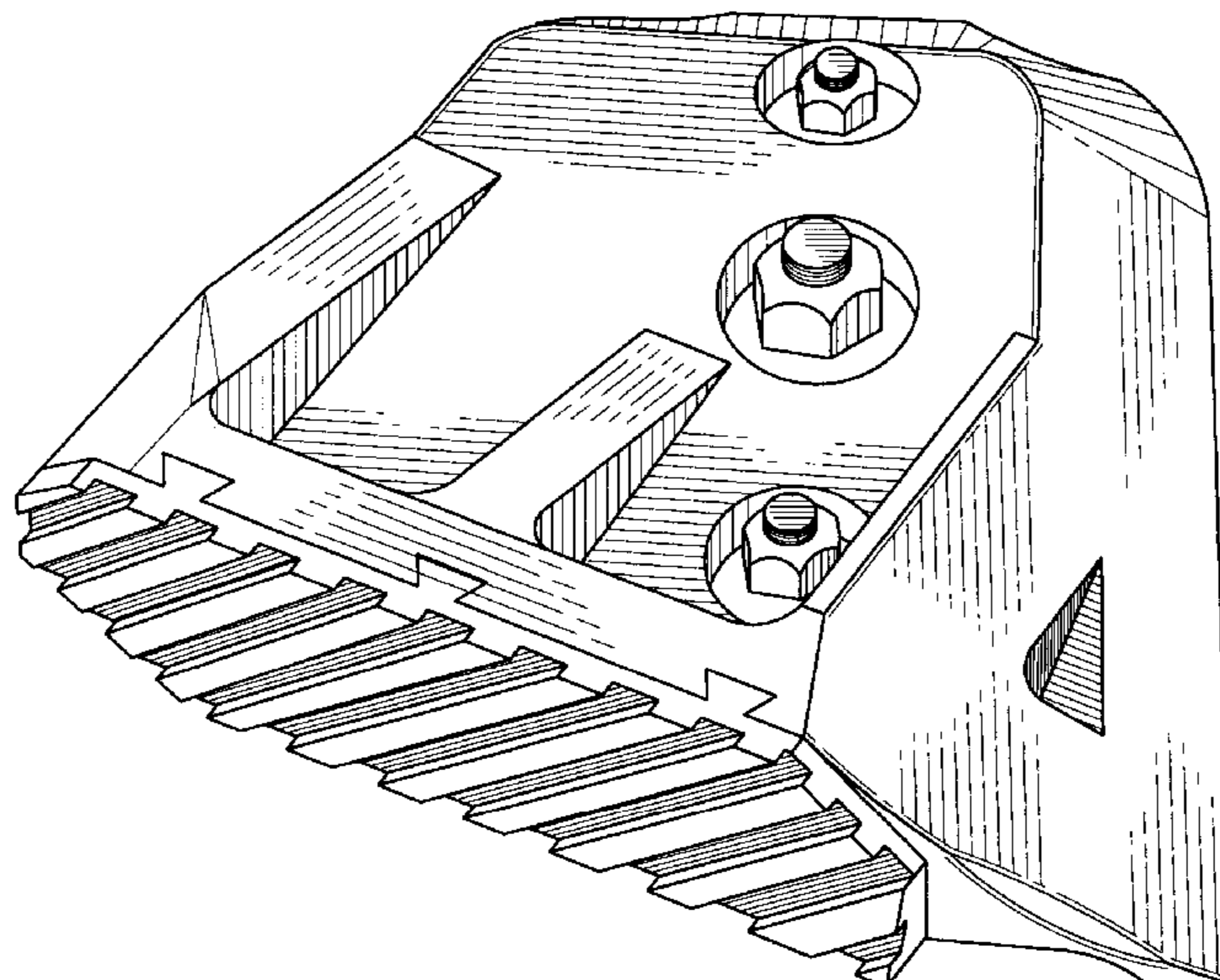

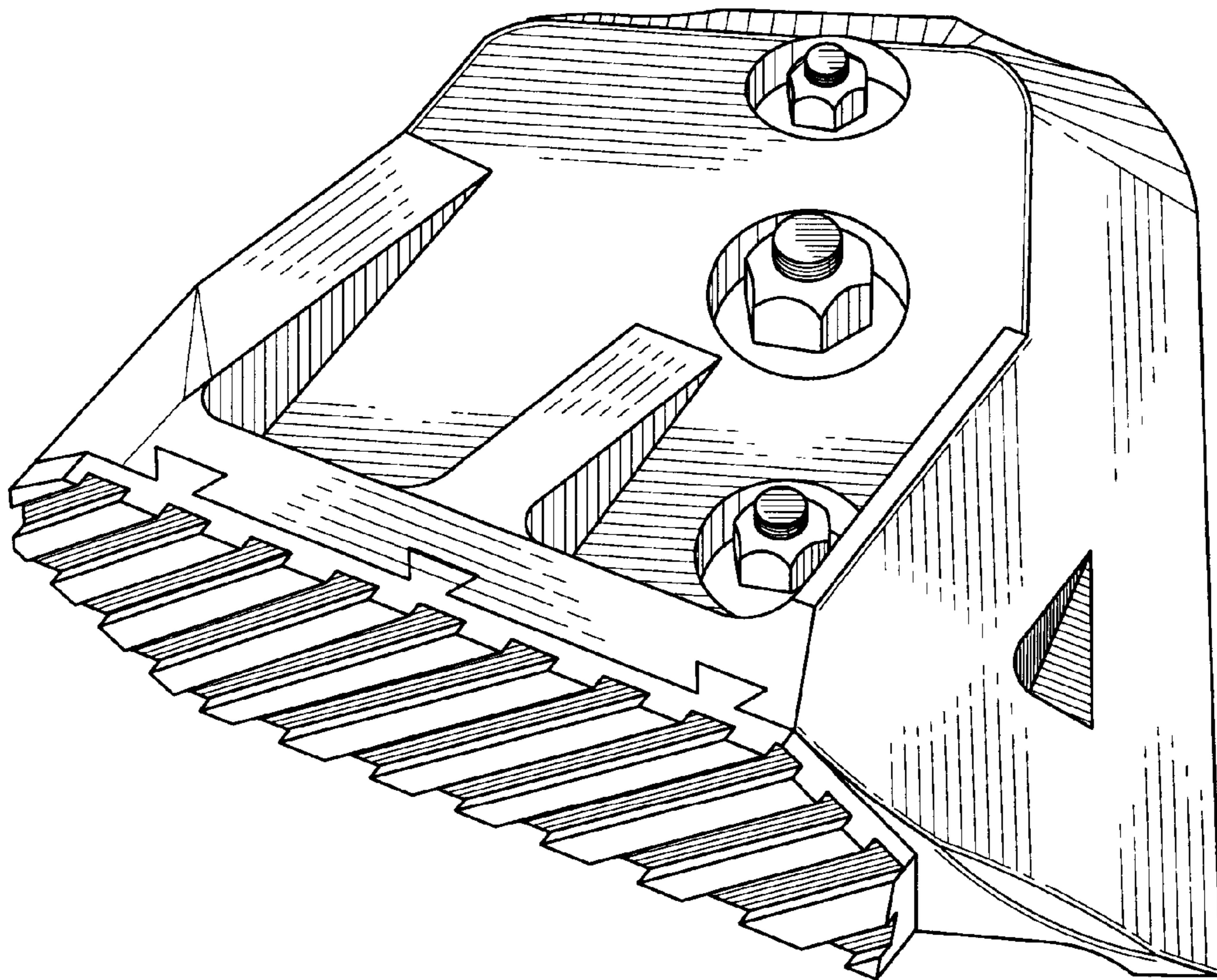

Fig. 1

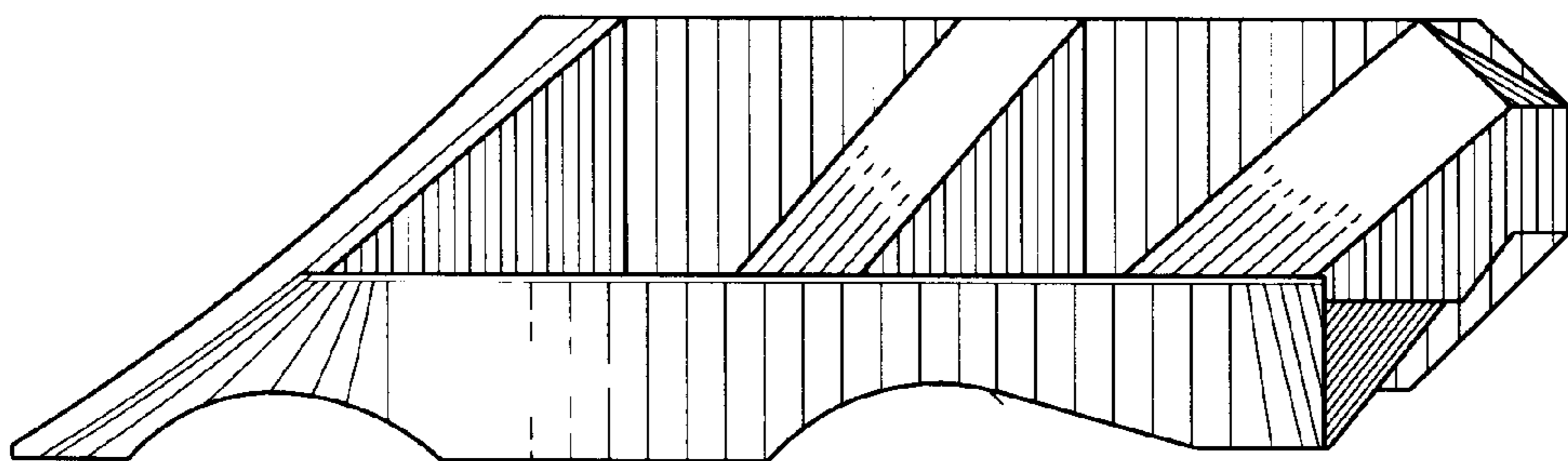

Fig. 2

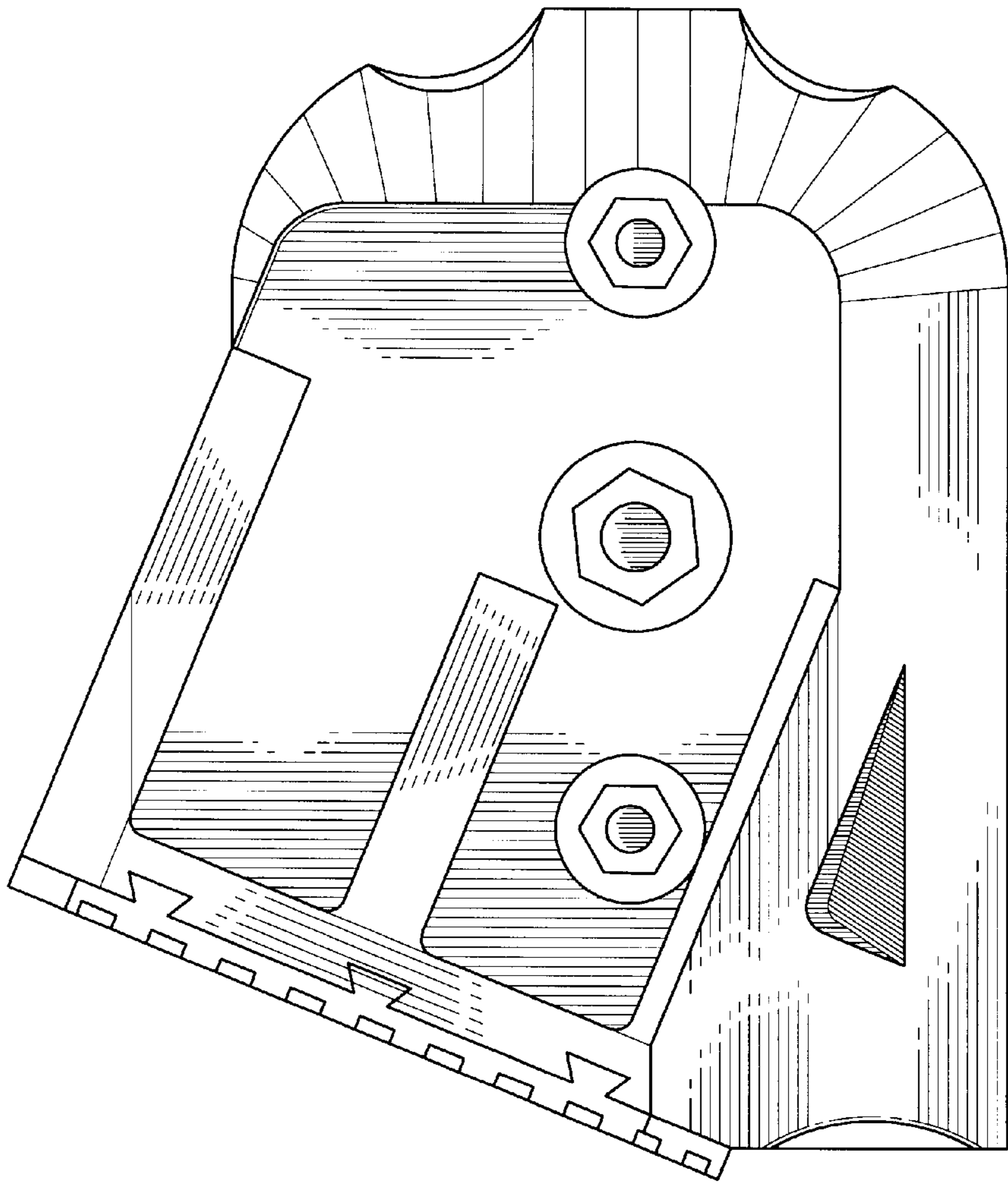

Fig. 3

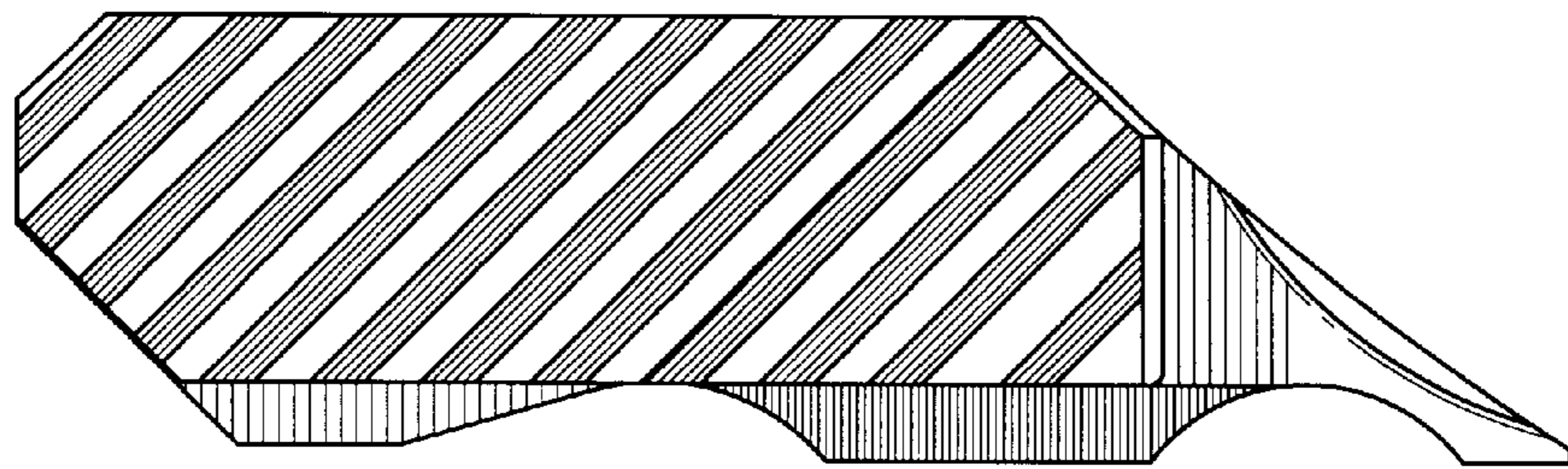

Fig. 4

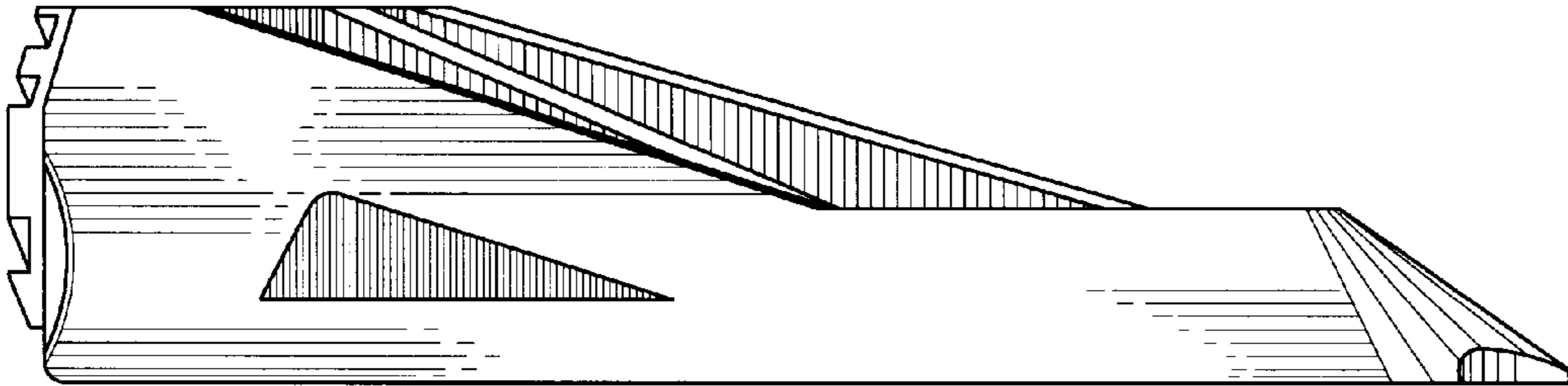

Fig. 5

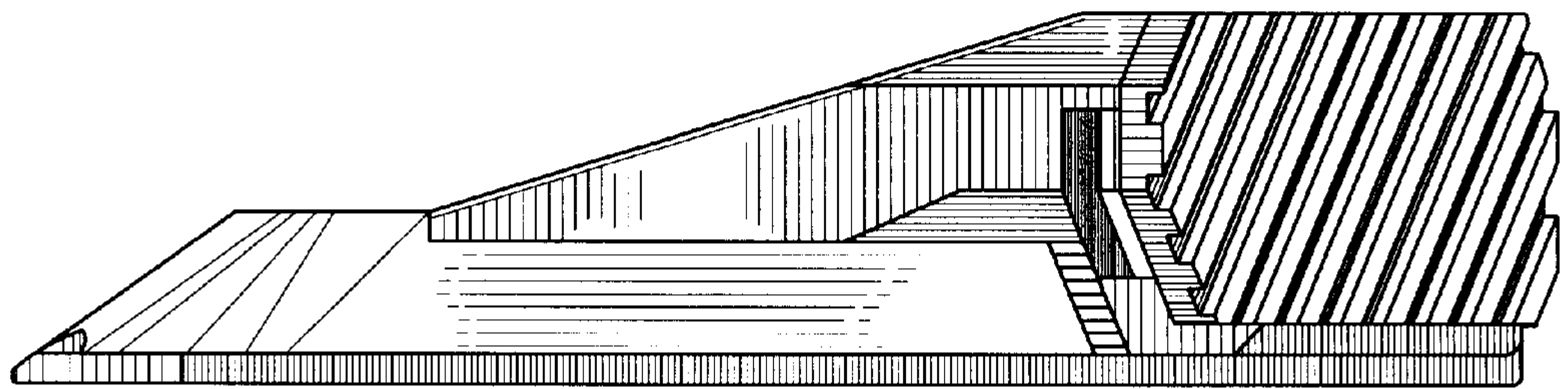

Fig. 6

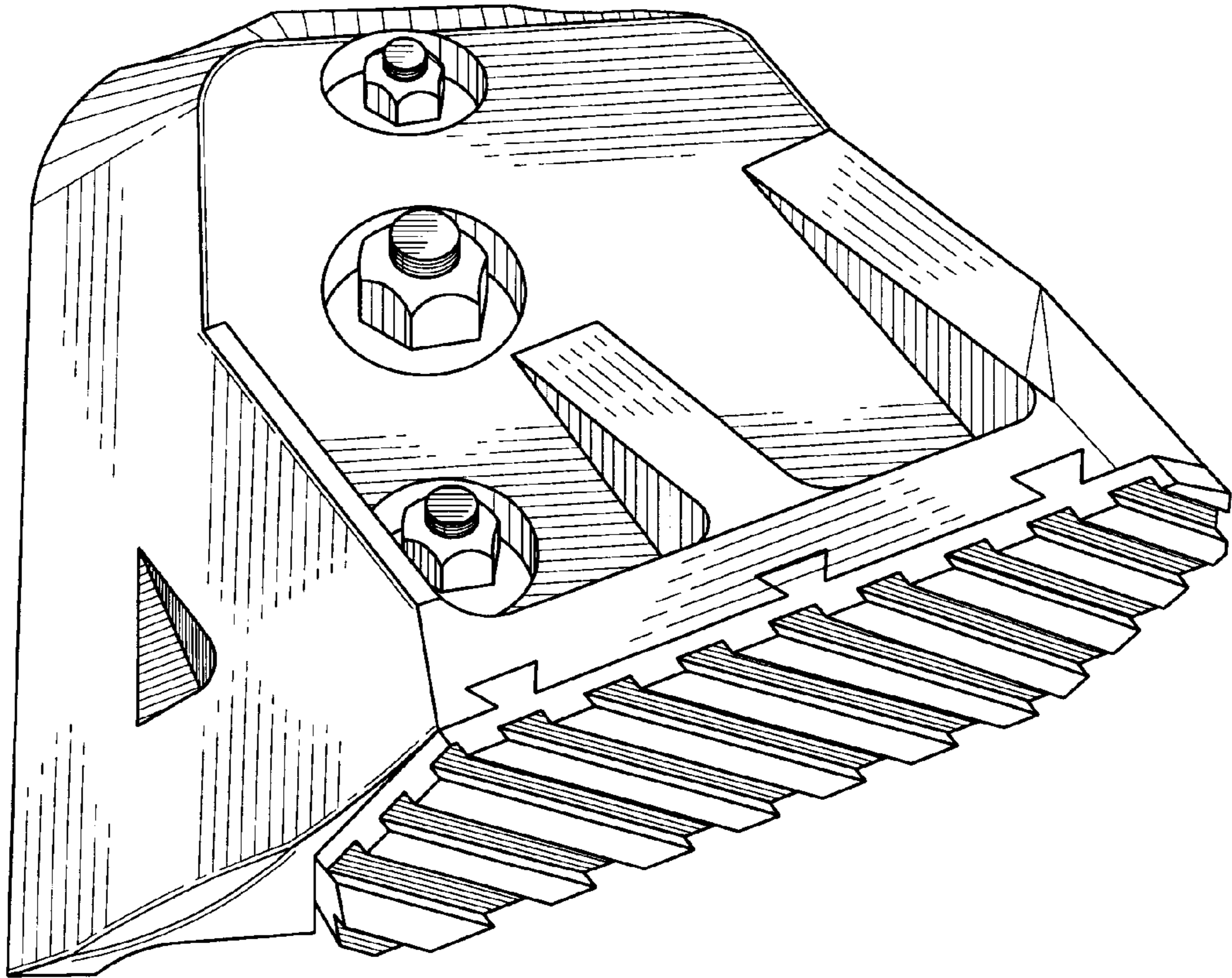

Fig. 7

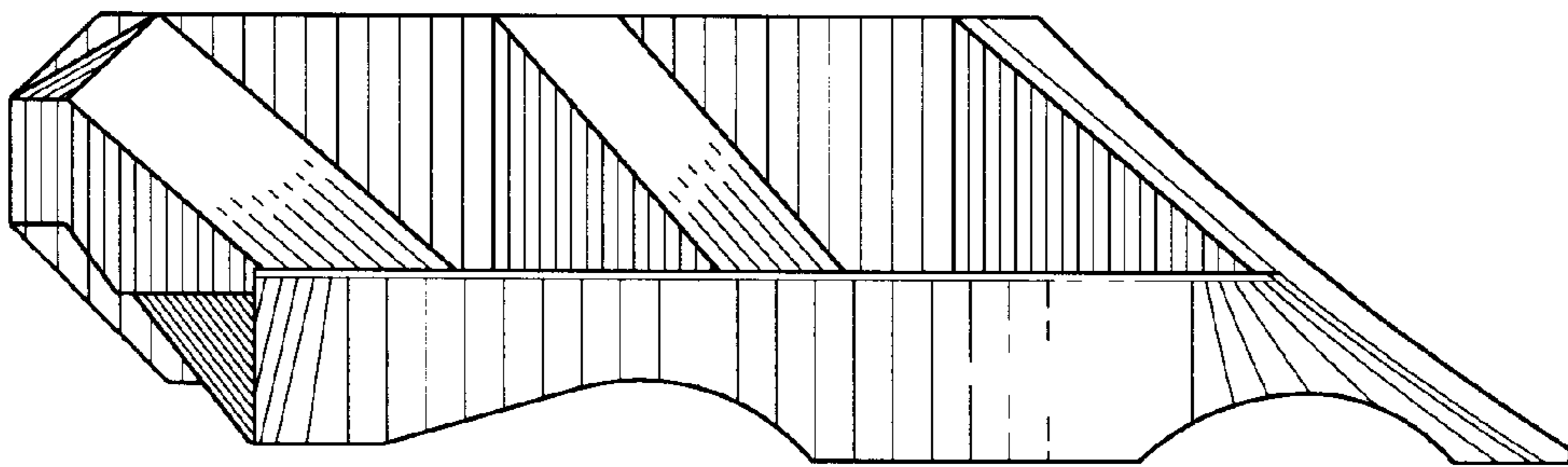

Fig. 8

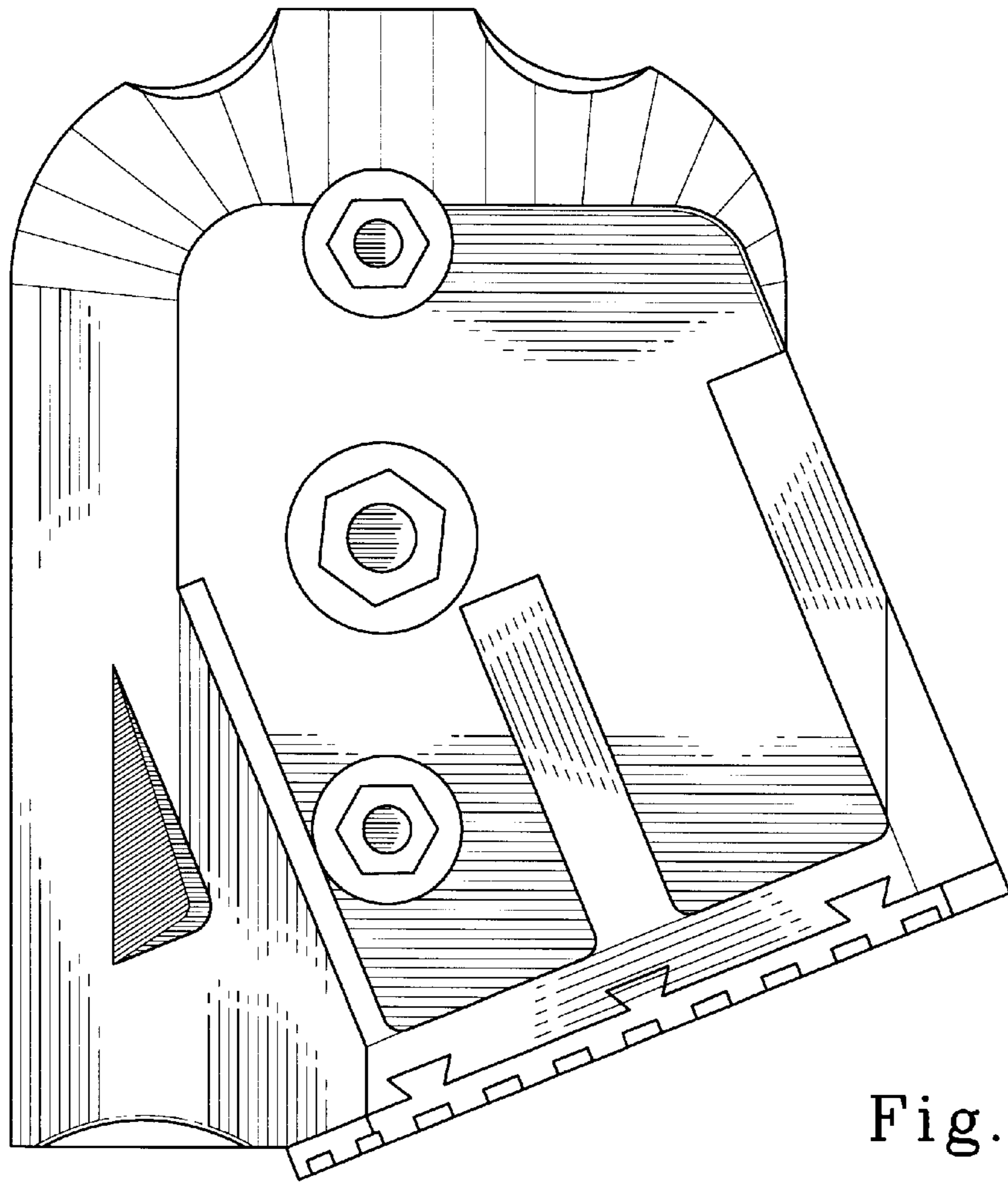

Fig. 9

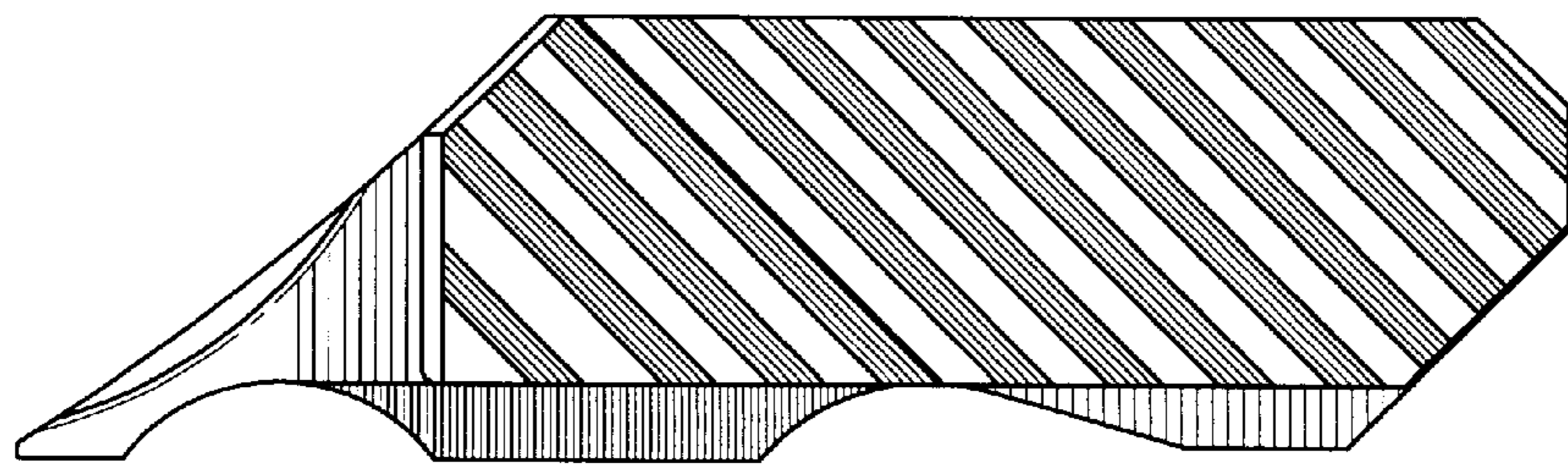

Fig. 10

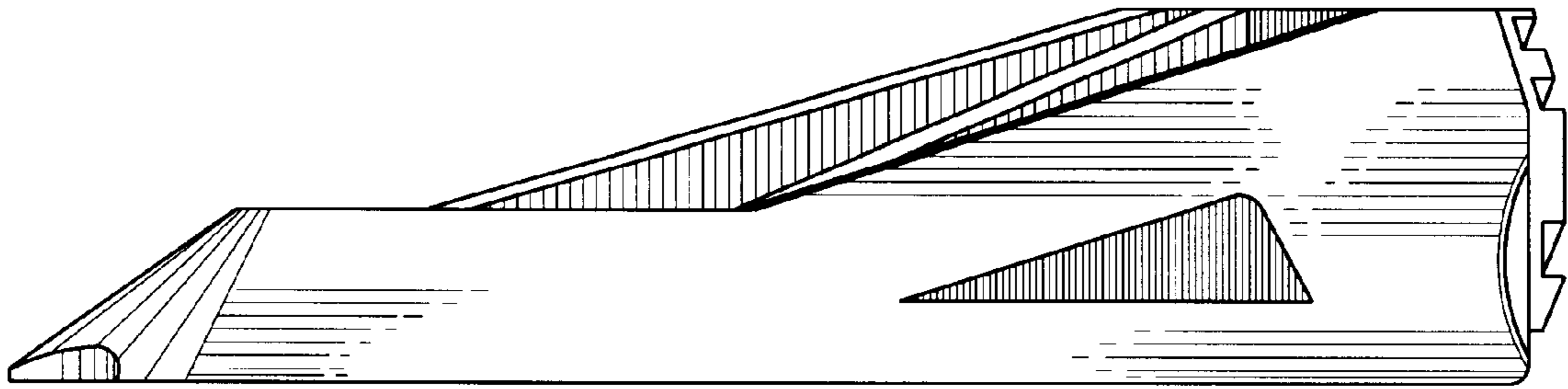

Fig. 11

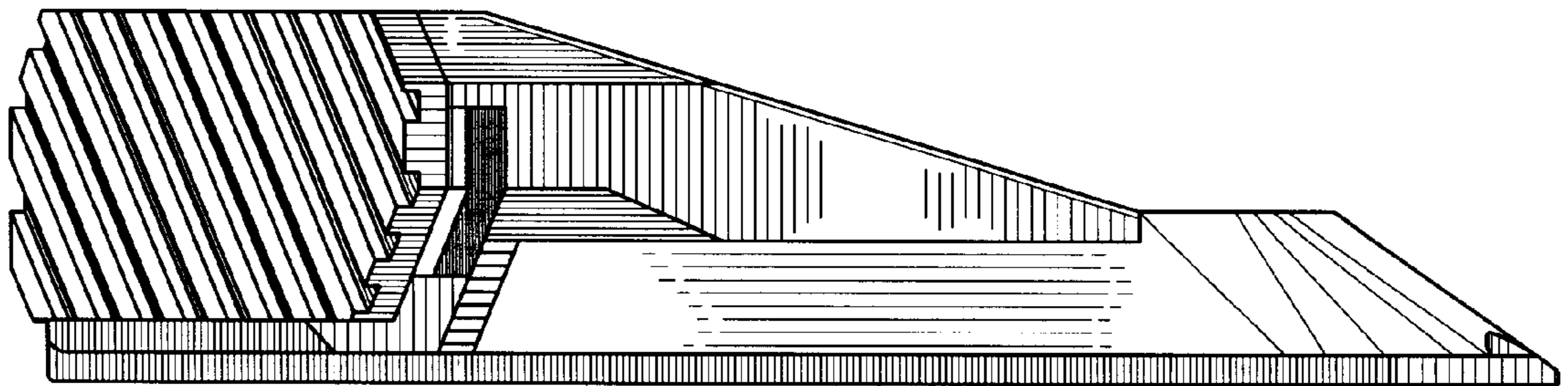

Fig. 12