



US00D411163S

United States Patent [19]

[11] Patent Number: **Des. 411,163**

Bunter

[45] Date of Patent: **** Jun. 22, 1999**

[54] **ADJUSTABLE ROLLER ASSEMBLY FOR USE WITH A VEHICLE ROOF RACK**

Attorney, Agent, or Firm—Salter & Michaelson

[76] Inventor: **William A. Bunter**, Sirois Rd.
—Arrowsic Island, Bath, Me. 04530

[57] **CLAIM**

The ornamental design for an adjustable roller assembly for use with a vehicle roof rack, as shown and described.

[**] Term: **14 Years**

DESCRIPTION

[21] Appl. No.: **29/078,876**

FIG. 1 is a front perspective view of an adjustable roller assembly for use with a vehicle roof rack shown mounted a rack, showing my new design;

[22] Filed: **Oct. 31, 1997**

FIG. 2 is an enlarged front perspective view thereof showing the roller located in the lowermost position;

[51] **LOC (6) Cl.** **12-16**

[52] **U.S. Cl.** **D12/414**

[58] **Field of Search** D12/400, 406,
D12/412, 414; 224/42.2, 309, 316-317,
322-329, 331, 321; 296/37.1

FIG. 3 is an enlarged right side view thereof;

FIG. 4 is an enlarged left side view of thereof;

FIG. 5 is an enlarged top plan view thereof;

FIG. 6 is an enlarged bottom view thereof;

FIG. 7 is an enlarged rear elevation view thereof;

FIG. 8 is an enlarged front elevational view thereof;

FIG. 9 is an enlarged perspective view showing the roller in the intermediate position; and,

FIG. 10 is an enlarged perspective view showing the roller located in the uppermost position.

[56] **References Cited**

U.S. PATENT DOCUMENTS

D. 294,137	2/1988	Robson	D12/414
D. 299,224	1/1989	Kamaya	D12/414
D. 316,068	4/1991	Rasor et al.	D12/414
D. 334,162	3/1993	Cucheran et al.	D12/414
D. 334,373	3/1993	Cucheran	D12/414
D. 340,690	10/1993	Arvidsson	D12/414
D. 346,355	4/1994	Weger, Jr. et al.	D12/414
D. 359,943	7/1995	Cucheran et al.	D12/414
D. 380,188	6/1997	Prasatek et al.	D12/412
D. 382,533	8/1997	Okland	D12/414

The portions shown in broken lines in FIG. 1 are for information only and form no part of the instant design.

The adjustable roller assembly for use with a vehicle roof rack has been shown broken away in FIGS. 2 and 5-10 for ease of illustration.

Primary Examiner—Doris V. Coles

Assistant Examiner—Stacia Sinuik

1 Claim, 5 Drawing Sheets

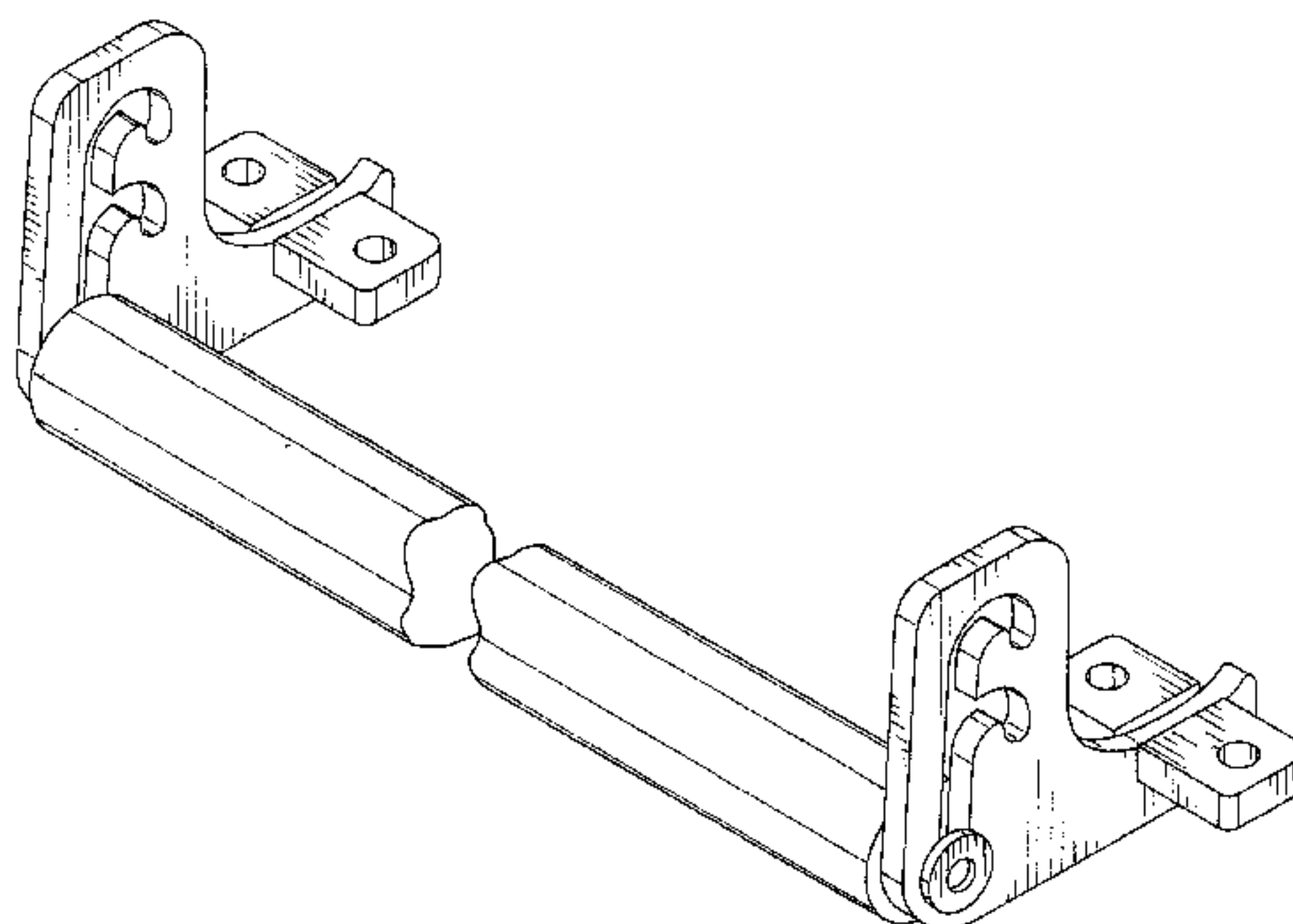
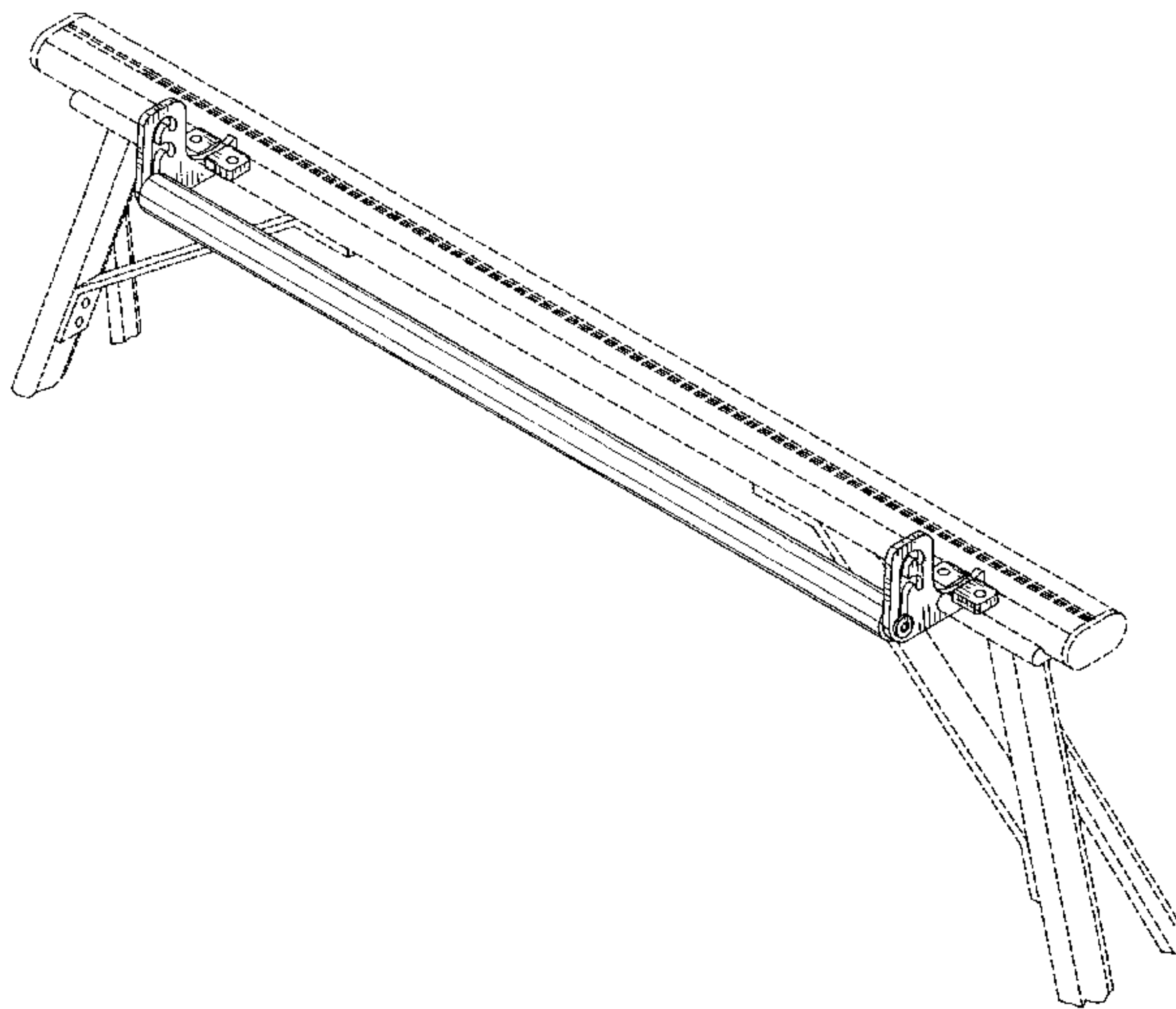

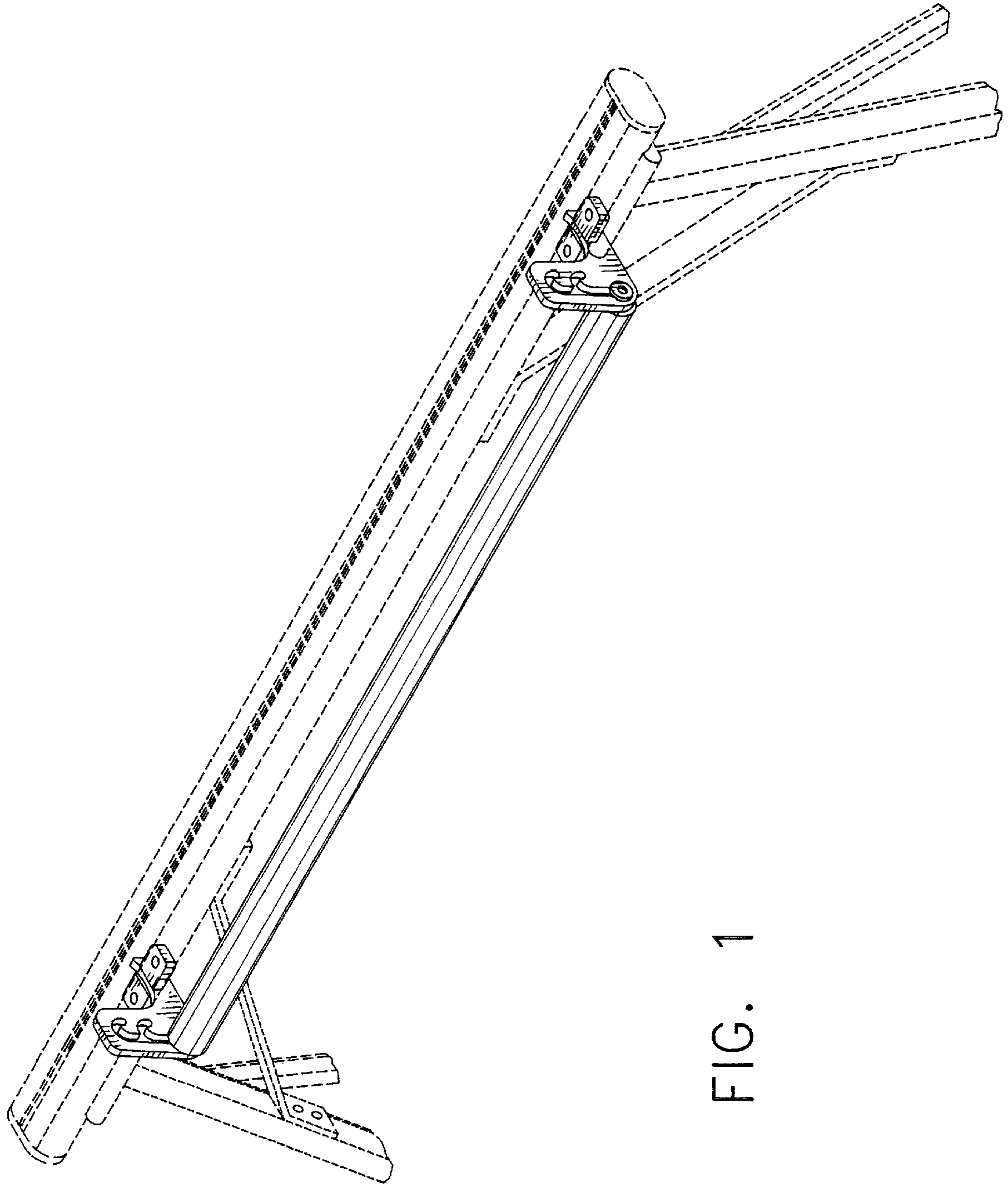

FIG. 1

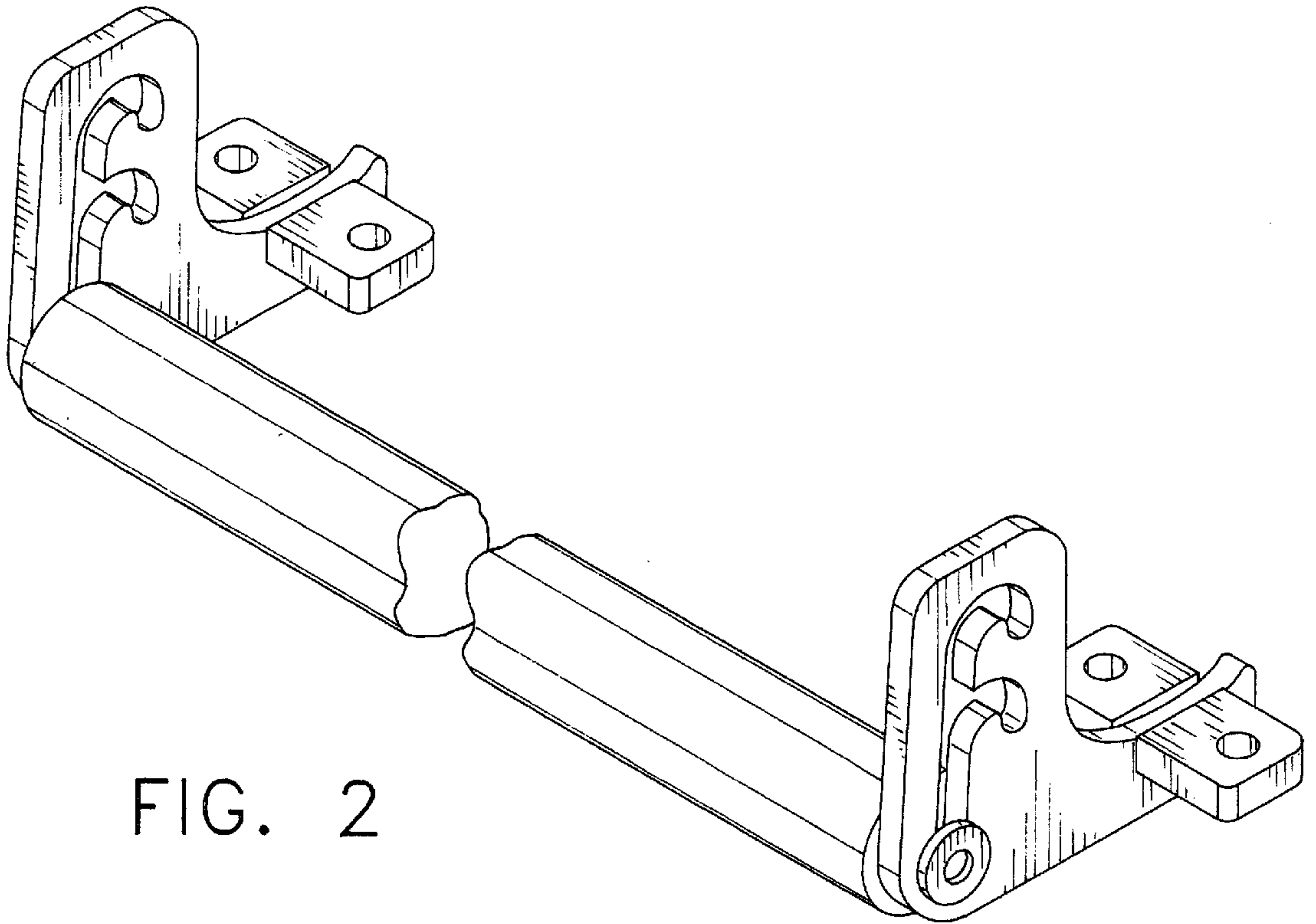

FIG. 2

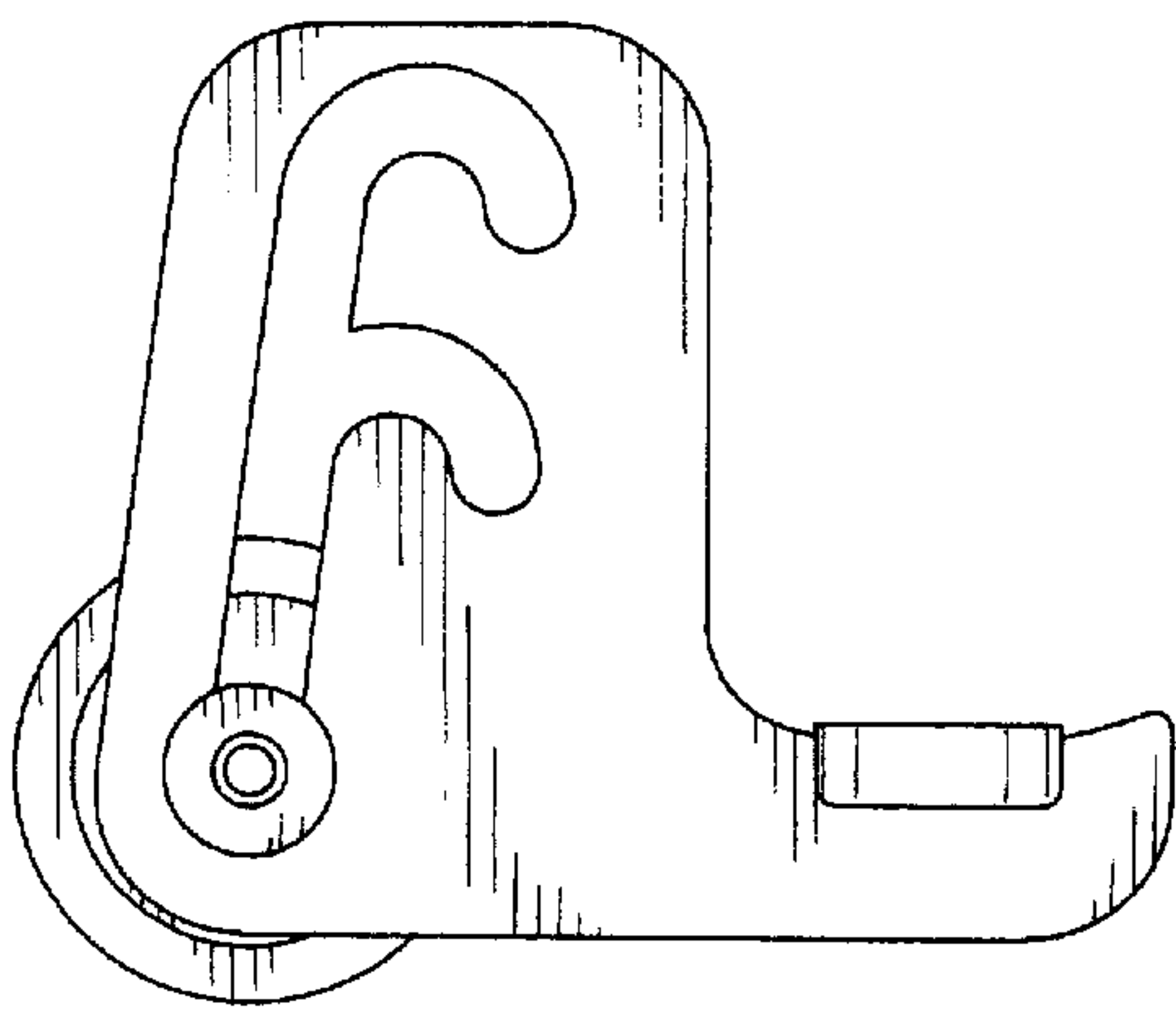

FIG. 3

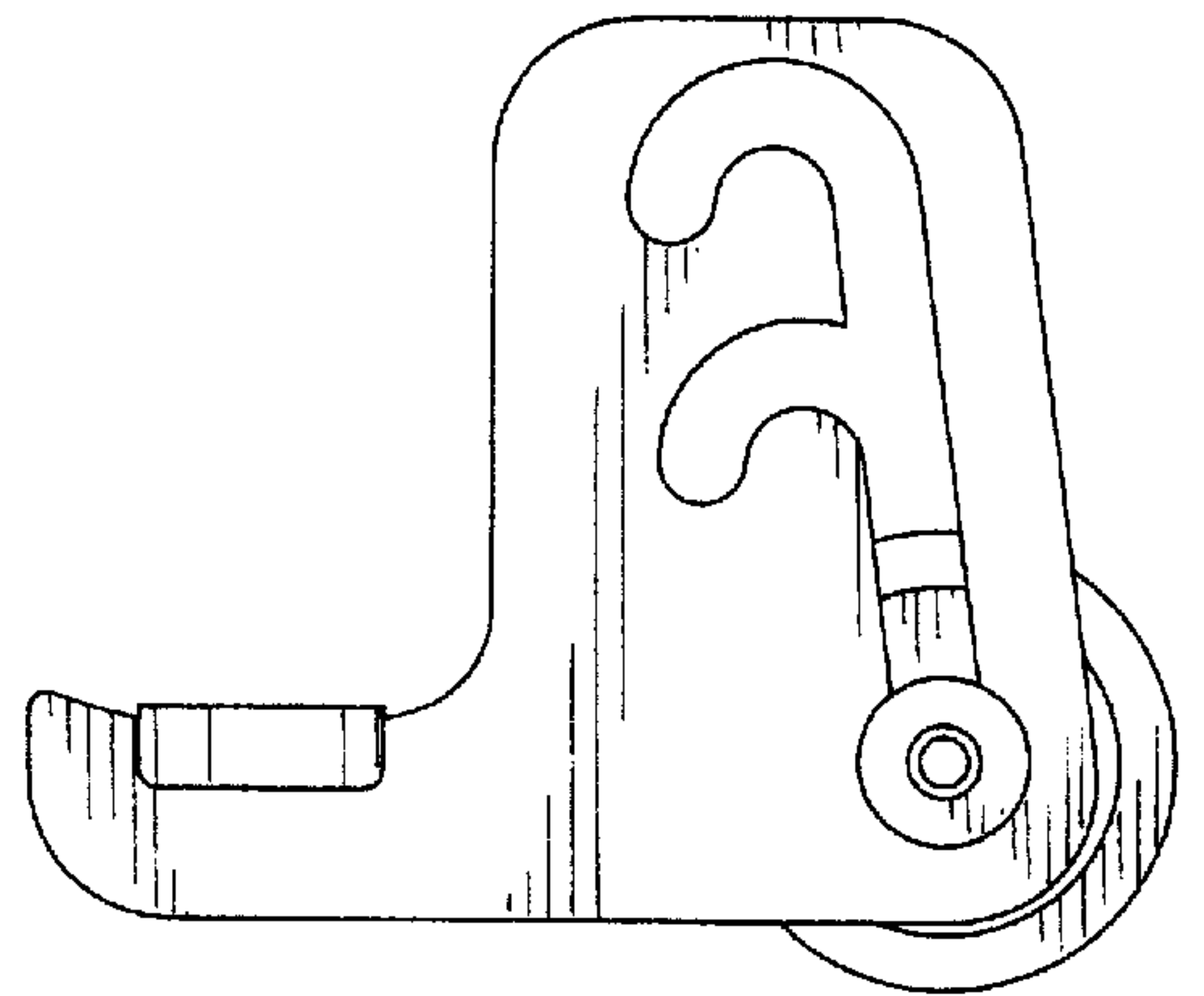

FIG. 4

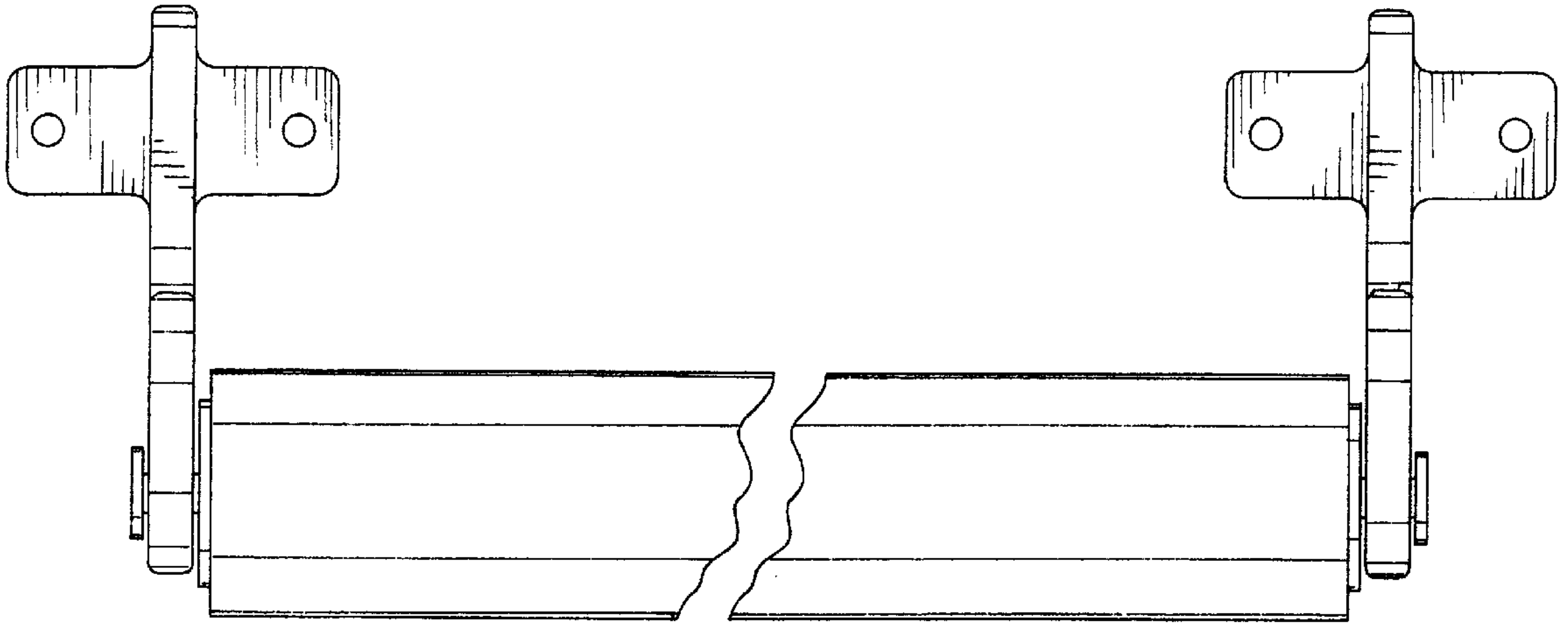

FIG. 5

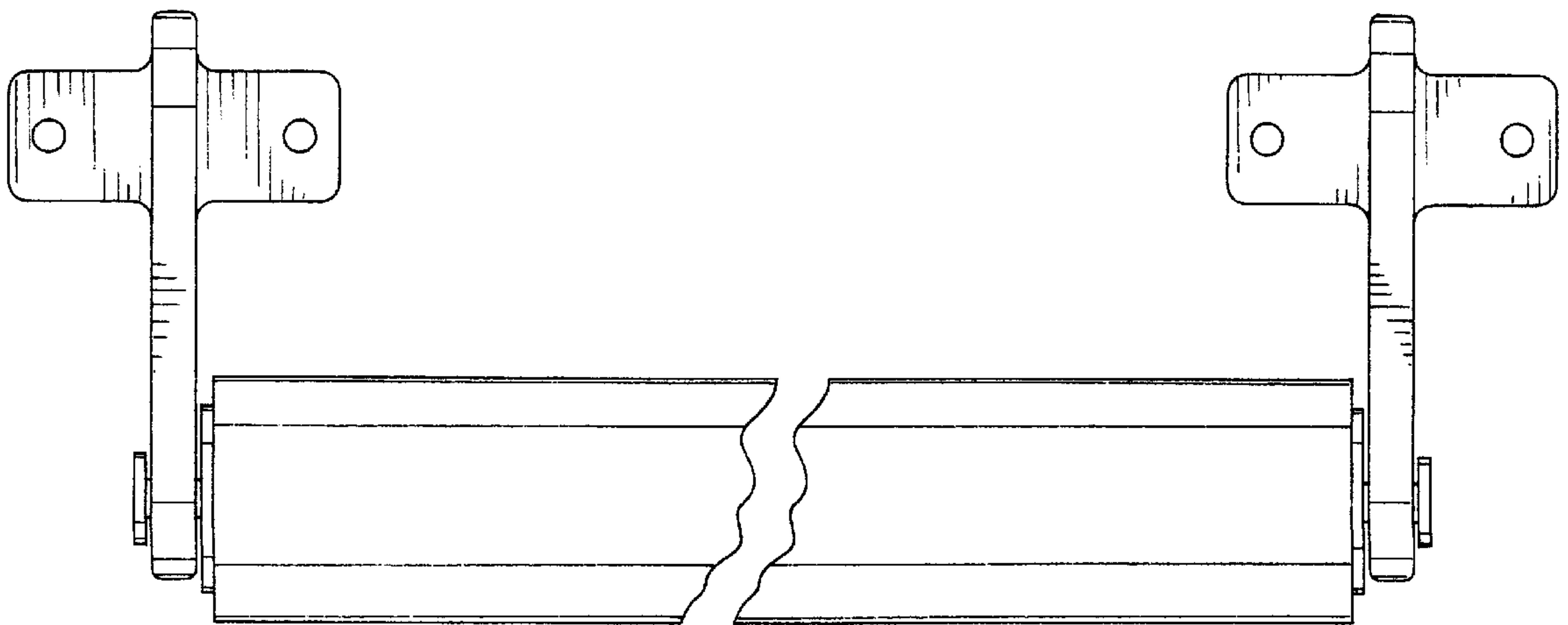

FIG. 6

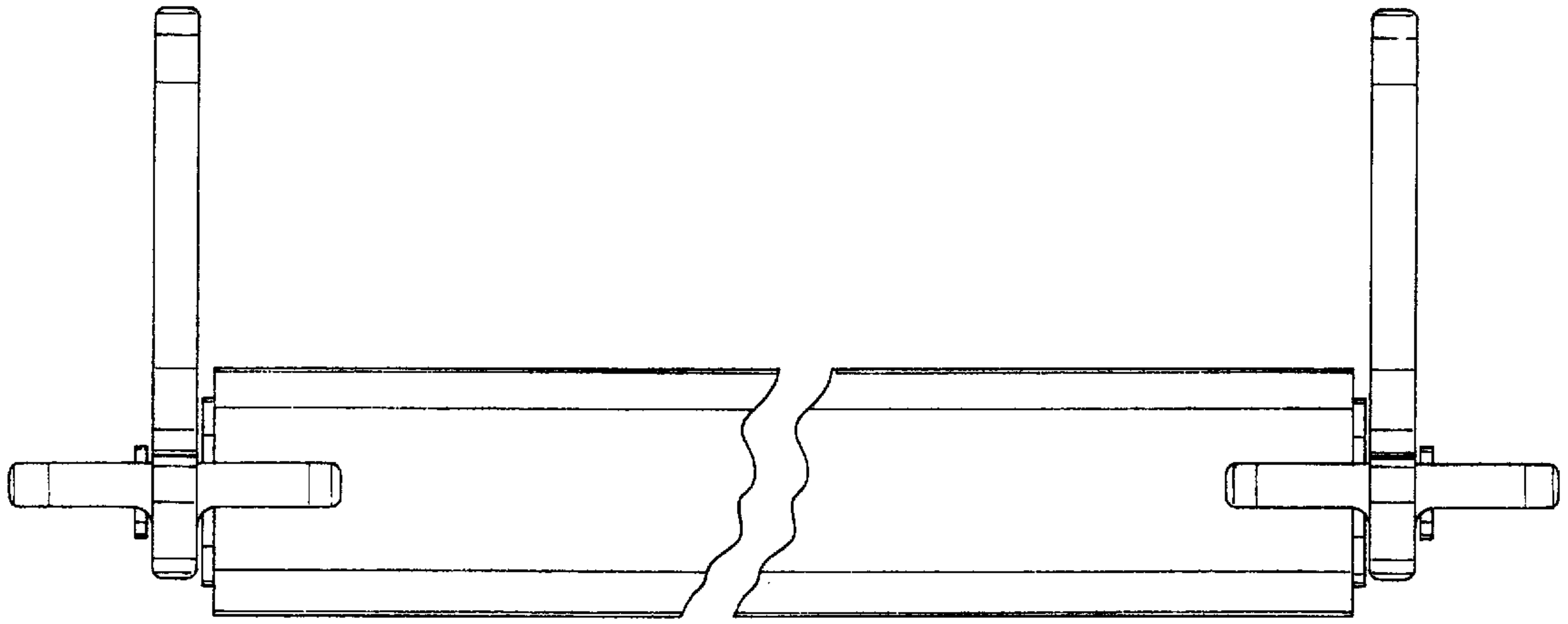

FIG. 7

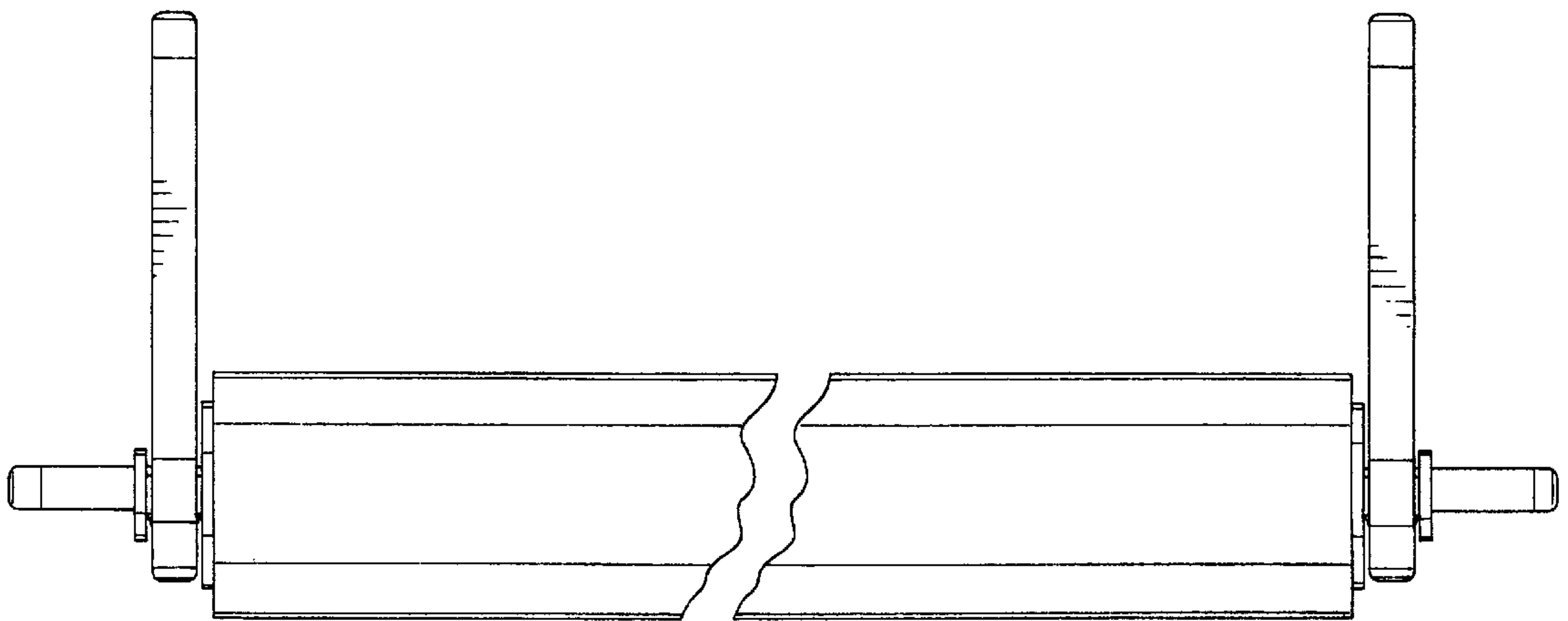

FIG. 8

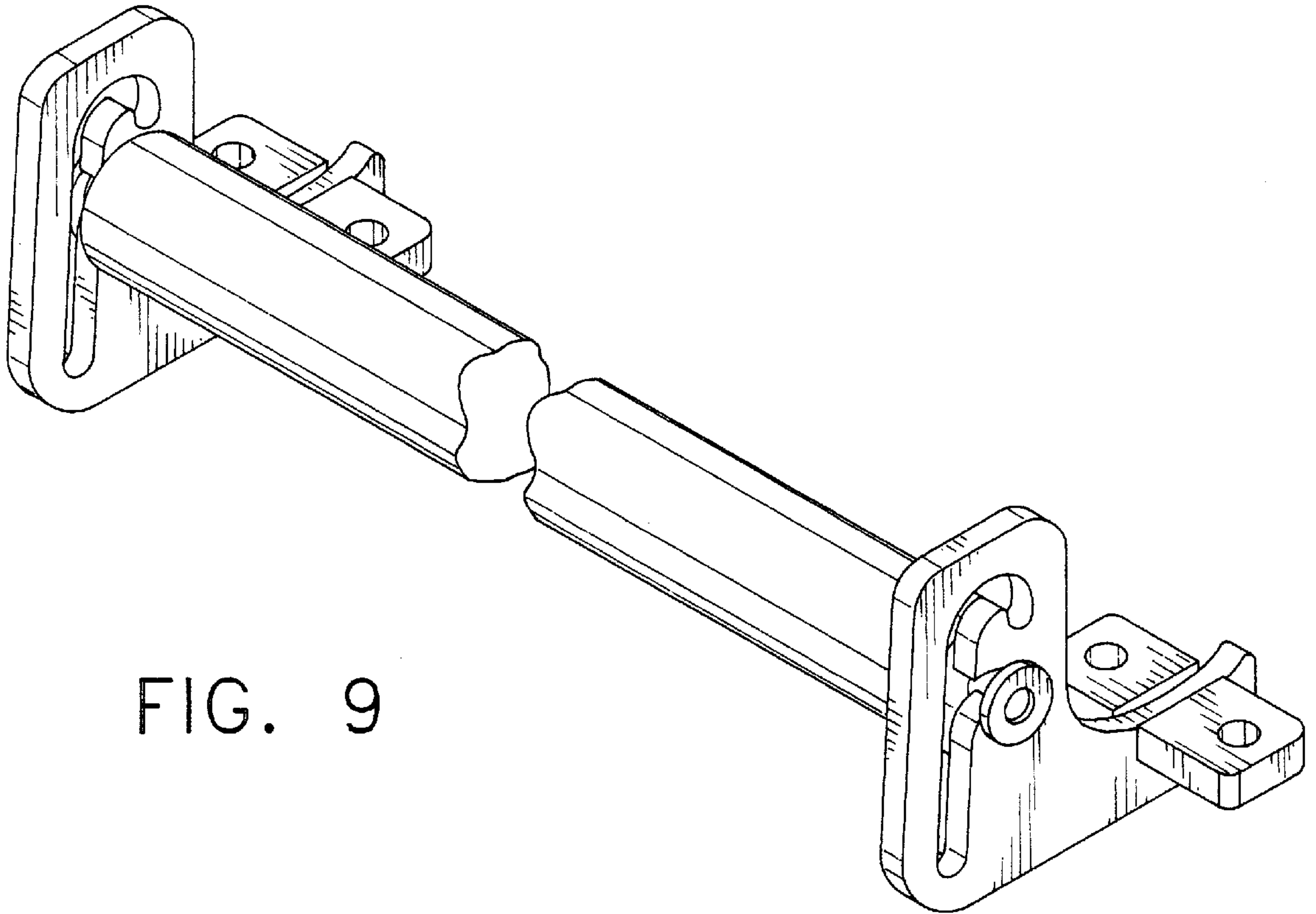

FIG. 9

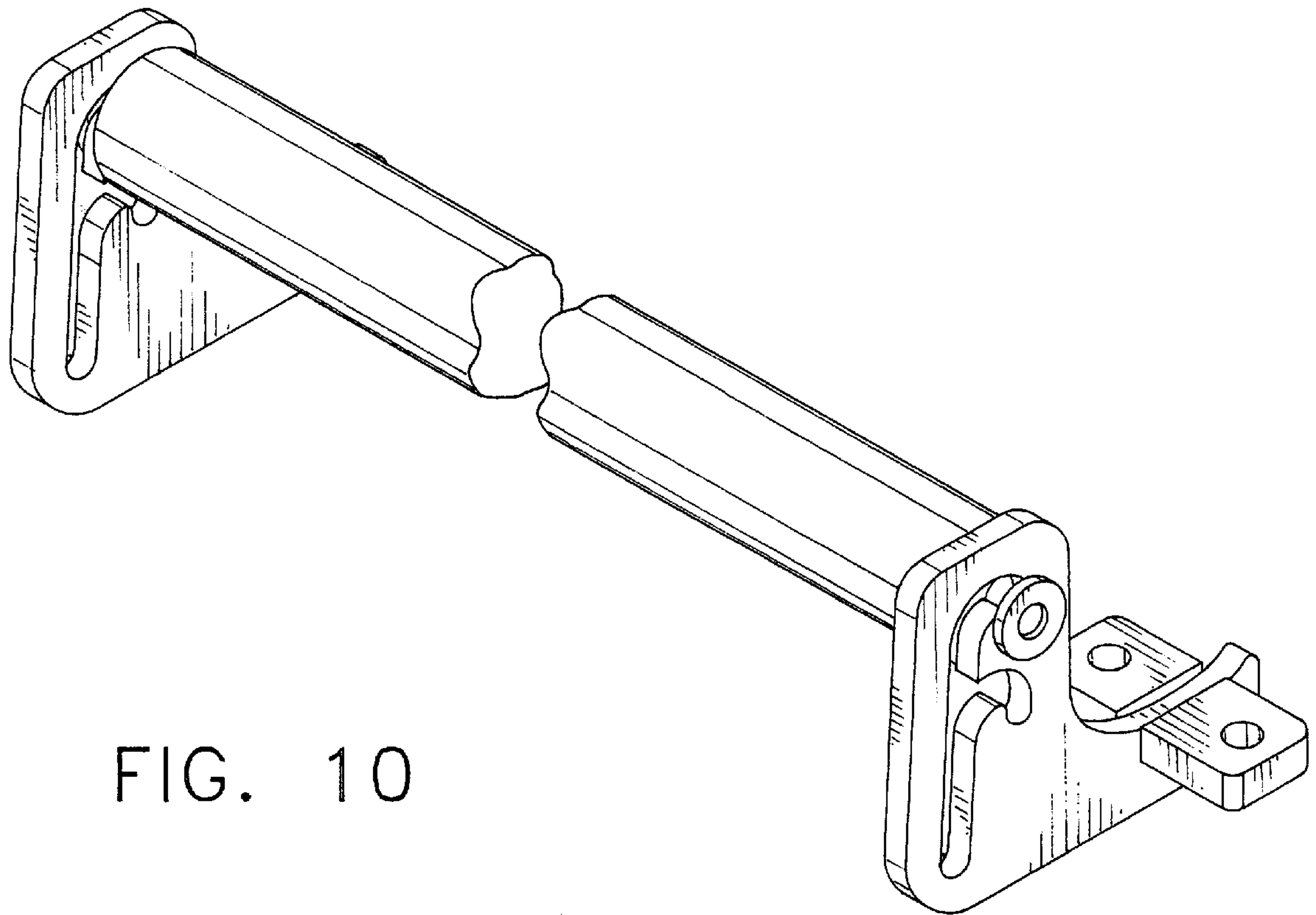

FIG. 10